



THE DATASHEET OF 6N136S



1Mbit/s High Speed Transistor Photo Coupler

Description

The 6N135, 6N136, SL450X series combine an AlGaAs infrared emitting diode as the emitter which is optically coupled to a silicon high speed photo transistor in a plastic DIP8 package with different lead forming options.

A separate design between photodiode and transistor reduces the base-collector capacitance of the input transistor which improves the speed by several orders of magnitude over conventional phototransistor optocouplers.

Features

- High isolation 5000 VRMS
- DC input with transistor output
- Operating temperature range - 55 °C to 100 °C
- REACH compliance
- Halogen free (Optional)
- MSL class 1
- Regulatory Approvals
 - UL - UL1577
 - VDE - EN60747-5-5(VDE0884-5)
 - CQC - GB4943.1, GB8898
 - cUL- CSA Component Acceptance Service Notice No. 5A

Applications

- Line receivers
- Telecommunication equipment
- Out interface to CMOS-LSTTL-TTL
- Wide bandwidth analog coupling
- Pulse transformer replacement
- Computer-peripheral interface

SCHEMATIC

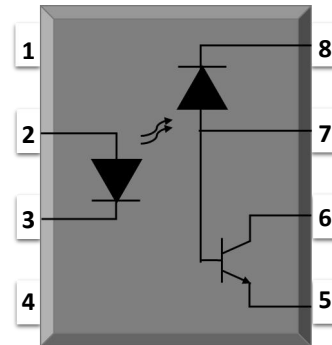

PIN DEFINITION

1.NC	8.VCC
2.Anode	7.VB(for 6N135/6N136) NC(for SL4502/SL4503)
3.Cathode	6.VO
4.NC	5.GND

OUTLINE

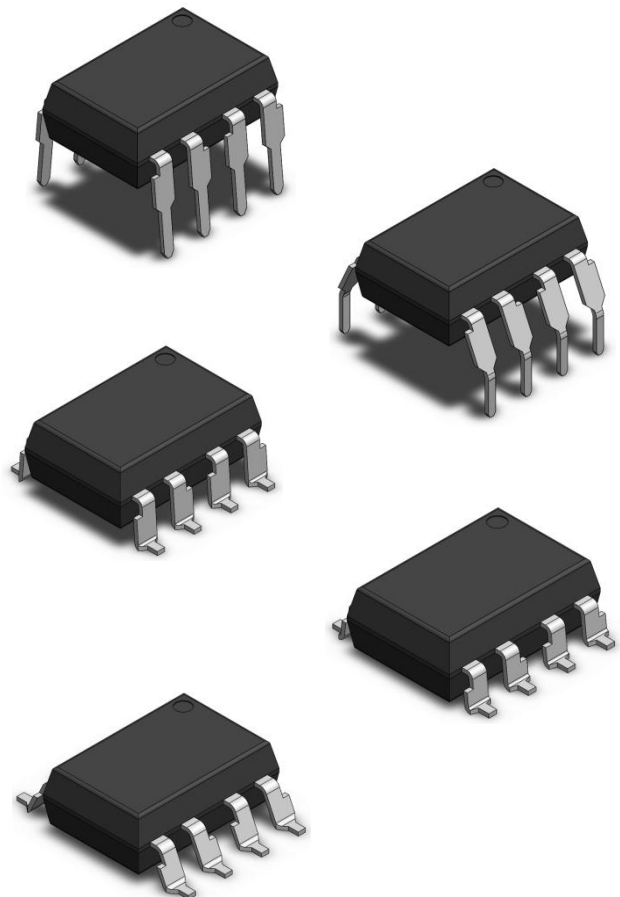

ABSOLUTE MAXIMUM RATINGS				
PARAMETER	SYMBOL	VALUE	UNIT	Note
INPUT				
Forward Current	I_F	25	mA	
Peak Forward Current	I_{FP}	50	mA	1
Peak Transient Current	$I_{F(trans)}$	1	A	2
Reverse Voltage	V_R	5	V	
Input Power Dissipation	P_I	100	mW	
OUTPUT				
Supply Voltage	V_{CC}	-0.5~30	V	
Output Voltage	V_O	-0.5~20	V	
Output Current	I_O	50	mA	
Emitter-Base Reverse Voltage	V_{EBR}	5	V	
Base Current	I_B	5	mA	
Output Power Dissipation	P_O	100	mW	
COMMON				
Total Power Dissipation	P_{tot}	200	mW	
Isolation Voltage	V_{iso}	5000	V _{rms}	3
Operating Temperature	T_{opr}	-55~100	°C	
Storage Temperature	T_{stg}	-55~150	°C	
Soldering Temperature	T_{sol}	260	°C	4

Note 1. 50% duty, 1ms P.W

Note 2. $\leq 1\mu s$ P.W,300pps

Note 3. AC For 1 Minute, R.H. = 40 ~ 60%

Note 4. For 10 seconds

ELECTRICAL OPTICAL CHARACTERISTICS

PARAMETER	SYMBOL	MIN	TYP	MAX	UNIT	TEST CONDITION	NOTE
INPUT(at Ta=0 to 70°C , unless specified otherwise)							
Forward Voltage	V_F	-	1.45	1.8	V	$I_F=16\text{mA}$	
Reverse Current	I_R	-	-	10	μA	$V_R=5\text{V}$	
Input Capacitance	C_{in}	-	60	-	pF	$V=0, f=1\text{MHz}$	
OUTPUT(at Ta=0 to 70°C , unless specified otherwise)							
High Level Supply Current	I_{CCH}	-	0.01	1	μA	$I_F=0\text{mA}, V_O=\text{Open}, V_{CC}=15\text{V}, T_a=25^\circ\text{C}$	
		-	-	2	μA	$I_F=0\text{mA}, V_O=\text{Open}, V_{CC}=15\text{V}$	
Low Level Supply Current	I_{CCL}	-	200	-	μA	$I_F=16\text{mA}, V_O=\text{Open}, V_{CC}=15\text{V}$	
Logic High Output Current	I_{OH}	-	0.001	0.5	μA	$I_F=0\text{mA}, V_O=V_{CC}=5.5\text{V}, T_a=25^\circ\text{C}$	
		-	0.01	1	μA	$I_F=0\text{mA}, V_O=V_{CC}=15\text{V}, T_a=25^\circ\text{C}$	
		-	-	50	μA	$I_F=0\text{mA}, V_O=V_{CC}=15\text{V}$	

ELECTRICAL OPTICAL CHARACTERISTICS

PARAMETER	SYMBOL	MIN	TYP	MAX	UNIT	TEST CONDITION	NOTE	
TRANSFER CHARACTERISTICS(at Ta=0 to 70°C , unless specified otherwise)								
Current Transfer Ratio	6N135	7	-	50	μA	I _F = 16mA ,V _O = 0.4V, V _{CC} =4.5V, Ta=25°C		
	6N136 SL4502 SL4503	19	-	50				
	6N135	5	-	-			I _F = 16mA ,V _O = 0.5V, V _{CC} =4.5V	
	6N136 SL4502 SL4503	15	-	-				
Logic Low Output Voltage	6N135	-	0.18	0.4	μA	I _F = 16mA ,I _O = 1.1mA, V _{CC} =4.5V, Ta=25°C		
	6N136 SL4502 SL4503	-	0.25	0.4			I _F = 16mA ,I _O = 3mA, V _{CC} =4.5V, Ta=25°C	
	6N135	-	-	-			I _F = 16mA ,I _O =0.8mA, V _{CC} =4.5V	
	6N136 SL4502 SL4503	-	-	-			I _F = 16mA ,I _O =2.4mA, V _{CC} =4.5V	
Isolation Resistance	R _{iso}	10 ¹²	10 ¹⁴	-	Ω	DC500V, 40 ~ 60% R.H.		
Floating Capacitance	C _{IO}	-	0.3	1	pF	V=0, f=1MHz		

ELECTRICAL OPTICAL CHARACTERISTICS

PARAMETER	SYMBOL	MIN	TYP	MAX	UNIT	TEST CONDITION	NOTE	
SWITCHING CHARACTERISTICS(at Ta=0 to 70°C, I _F =16mA, V _{CC} =5V, unless specified otherwise)								
Propagation Delay Time to Logic Low	6N135	TPHL	-	0.35	1.5	μs	R _L =4.1kΩ, T _A =25°C	Fig.13
			-	-	2		R _L =4.1kΩ	
	6N136 SL4502 SL4503		-	0.35	0.8		R _L =1.9kΩ, T _A =25°C	
			-	-	1.0		R _L =1.9kΩ	
Propagation Delay Time to Logic High	6N135	TPLH	-	0.5	1.5	μs	R _L =4.1kΩ, T _A =25°C	Fig.13
			-	-	2		R _L =4.1kΩ	
	6N136 SL4502 SL4503		-	0.3	0.8		R _L =1.9kΩ, T _A =25°C	
			-	-	1.0		R _L =1.9kΩ	
Common Mode Transient Immunity at Logic High	6N135	CM _H	1000	-	-	V/μs	I _F = 0mA, V _{CM} =10Vpp, R _L =4.1kΩ, T _A =25°C	Fig.14
	6N136 SL4502		1000	-	-		I _F = 0mA, V _{CM} =10Vpp, R _L =1.9kΩ, T _A =25°C	
	SL4503		15000	20000	-		I _F = 0mA, V _{CM} =1500Vpp, R _L =1.9kΩ, T _A =25°C	
Common Mode Transient Immunity at Logic Low	6N135	CM _L	1000	-	-	V/μs	I _F = 16mA, V _{CM} =10Vpp, R _L =4.1kΩ, T _A =25°C	Fig.14
	6N136 SL4502		1000	-	-		I _F = 16mA, V _{CM} =10Vpp, R _L =1.9kΩ, T _A =25°C	
	SL4503		15000	20000	-		I _F = 16mA, V _{CM} =1500Vpp, R _L =1.9kΩ, T _A =25°C	

CHARACTERISTIC CURVES

Fig.1 Forward Current vs. Forward Voltage

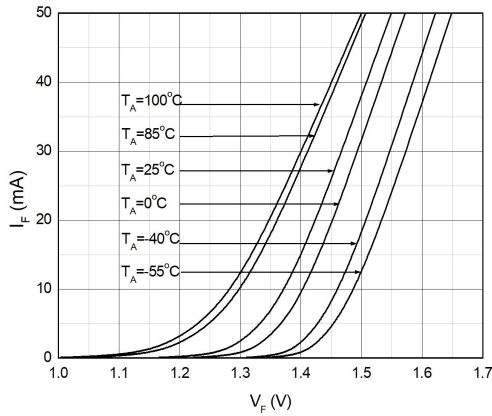

Fig.2 Forward Voltage vs. Ambient Temperature

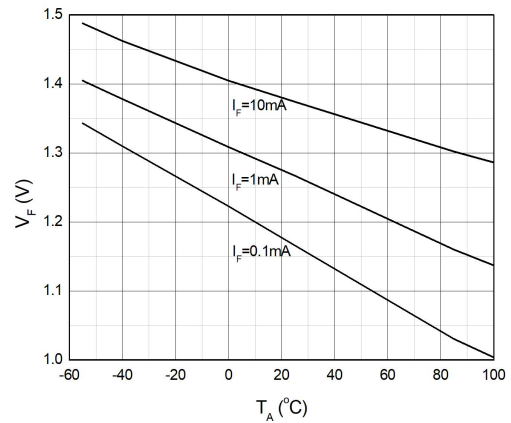

Fig.3 Input Threshold Current vs. Ambient Temperature

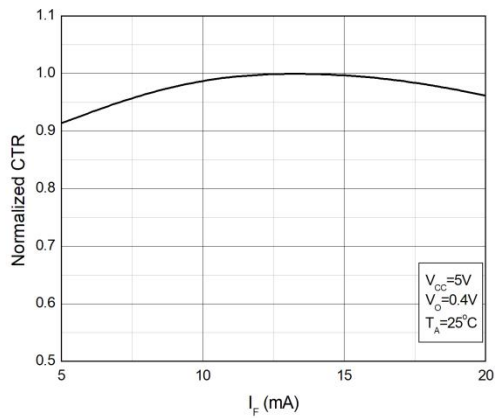

Fig.4 Input Threshold Current vs. Ambient Temperature

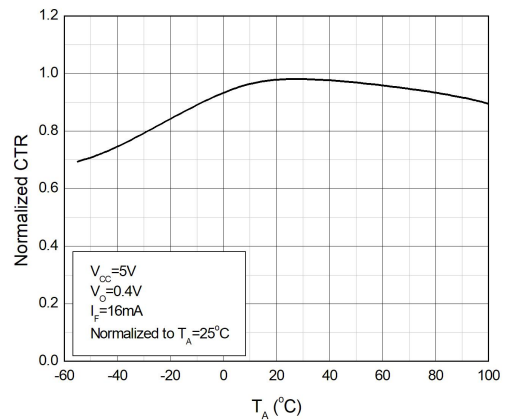

Fig.5 Low Level Output Current vs. Ambient Temperature

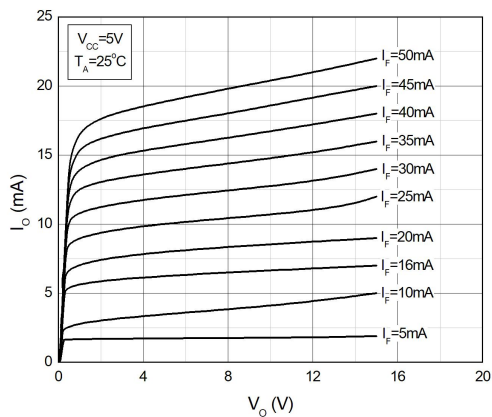
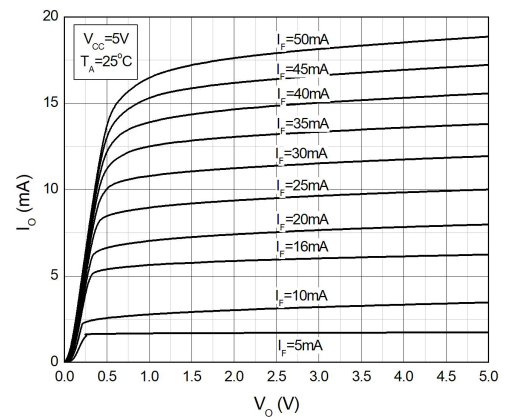

Fig.6 Low Level Output Current vs. Ambient Temperature



CHARACTERISTIC CURVES

Fig.7 Low Level Output Voltage vs. Ambient Temperature

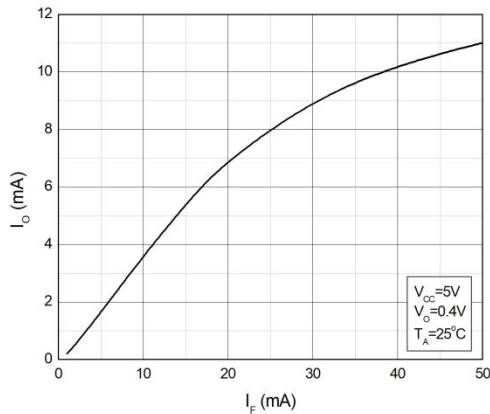

Fig.8 Low Level Output Voltage vs. Ambient Temperature

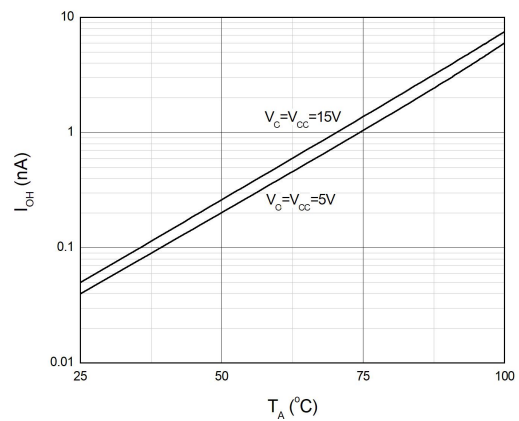

Fig.9 High Level Output Current vs. Ambient Temperature

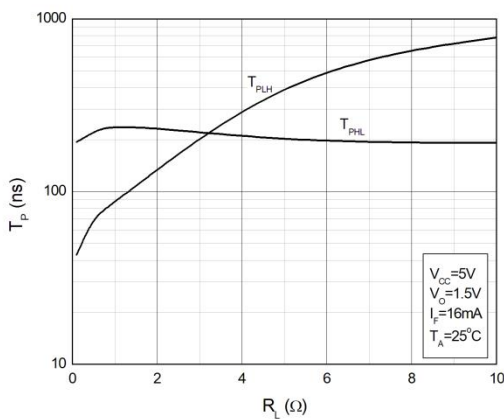

Fig.10 High Level Output Current vs. Ambient Temperature

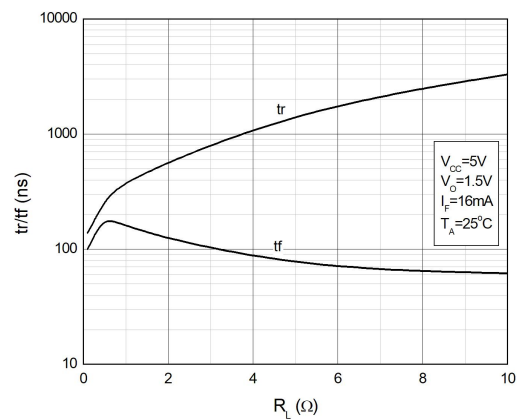

Fig.11 Output Voltage vs. Forward Current

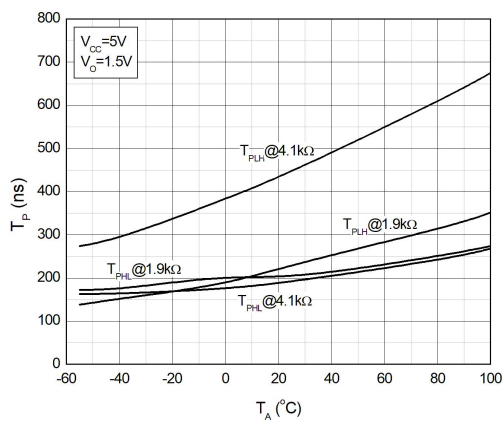
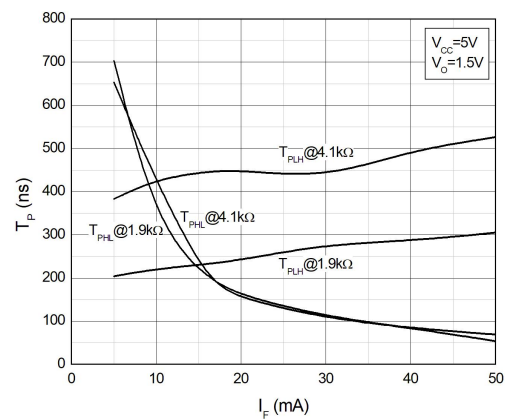

Fig.12 Output Voltage vs. Forward Current



TEST CIRCUITS

Fig.13 Test Circuits for TPHL, TPLH, tr, tf

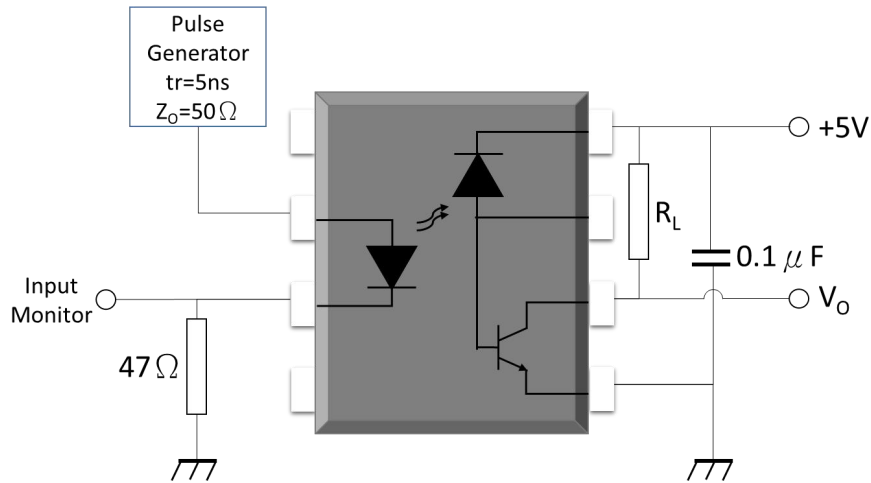
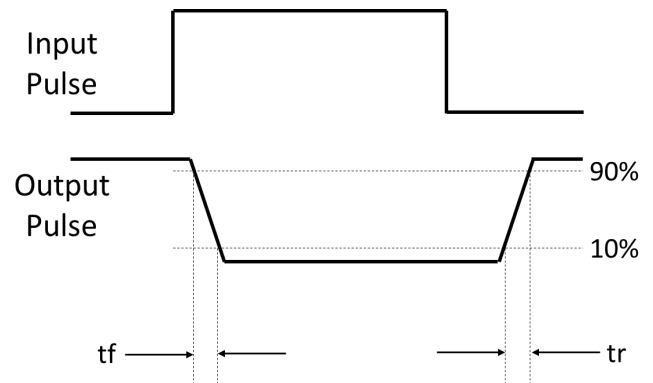
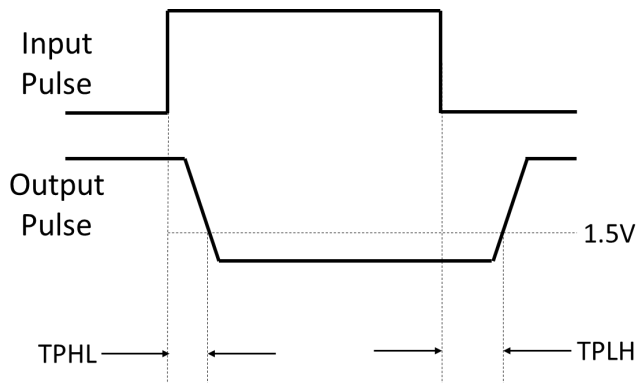

Fig.14 Waveforms of TPHL, TPLH, tr, tf



TEST CIRCUITS

Fig.15 Test Circuits for Common Mode Transient Immunity

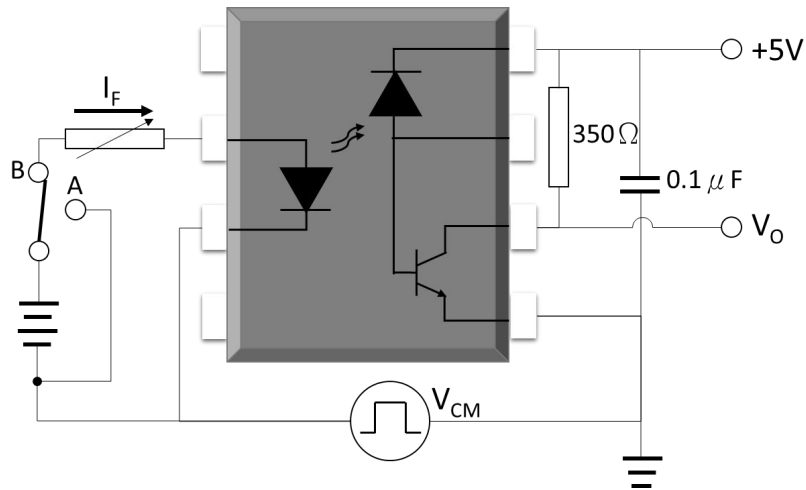
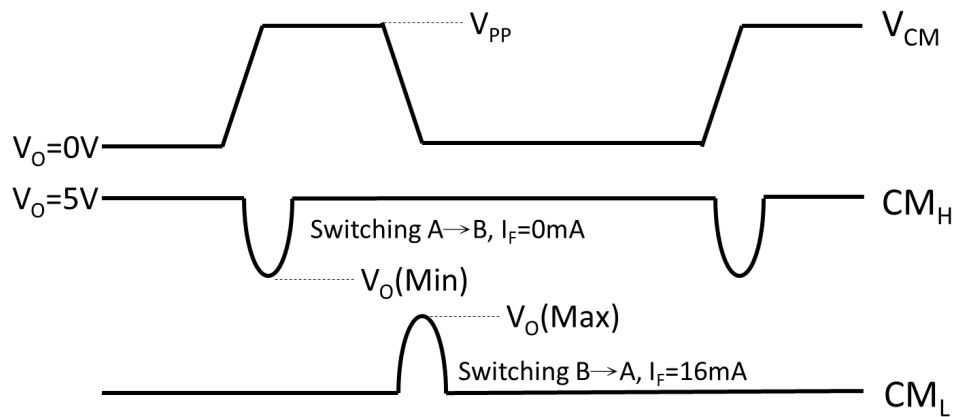
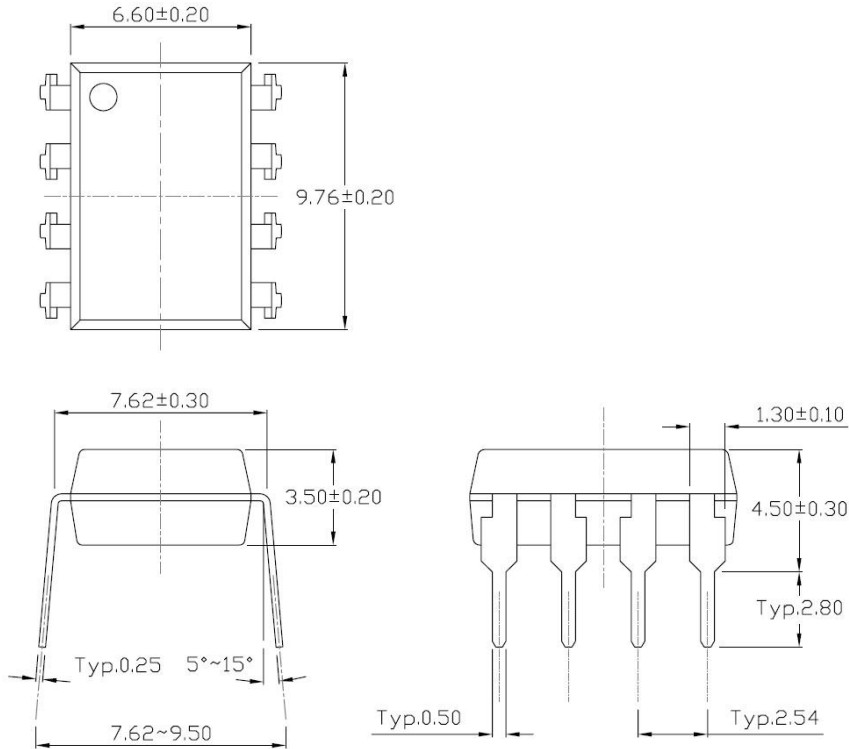

Fig.16 Waveforms of Common Mode Transient Immunity



PACKAGE DIMENSIONS (Dimensions in mm unless otherwise stated)

Standard DIP – Through Hole (DIP Type)



Gullwing (400mil) Lead Forming – Through Hole (M Type)

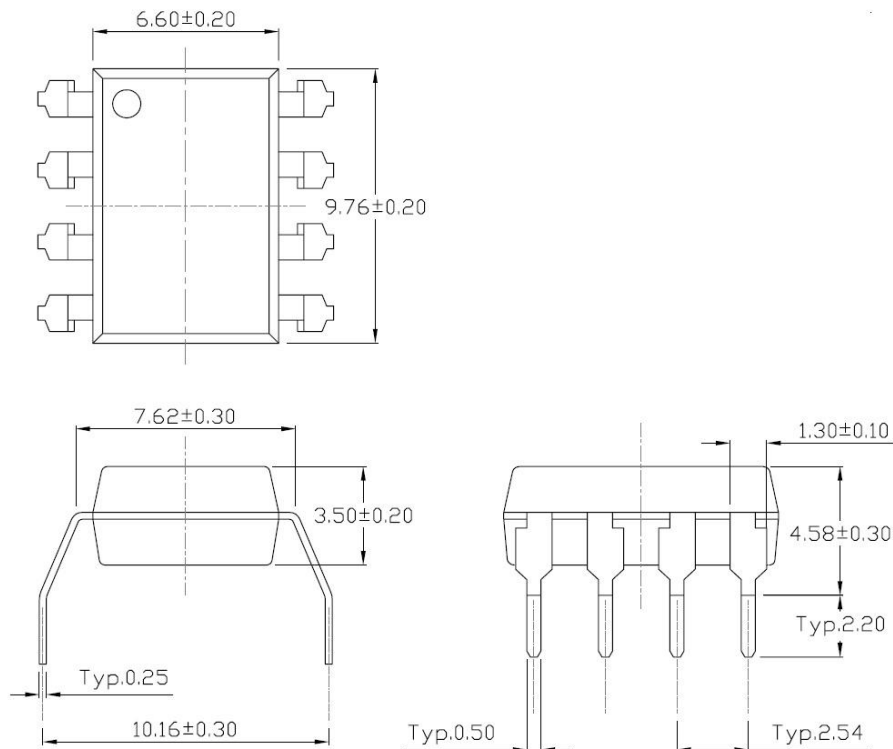

PACKAGE DIMENSIONS (Dimensions in mm unless otherwise stated)

Surface Mount Lead Forming (S Type)

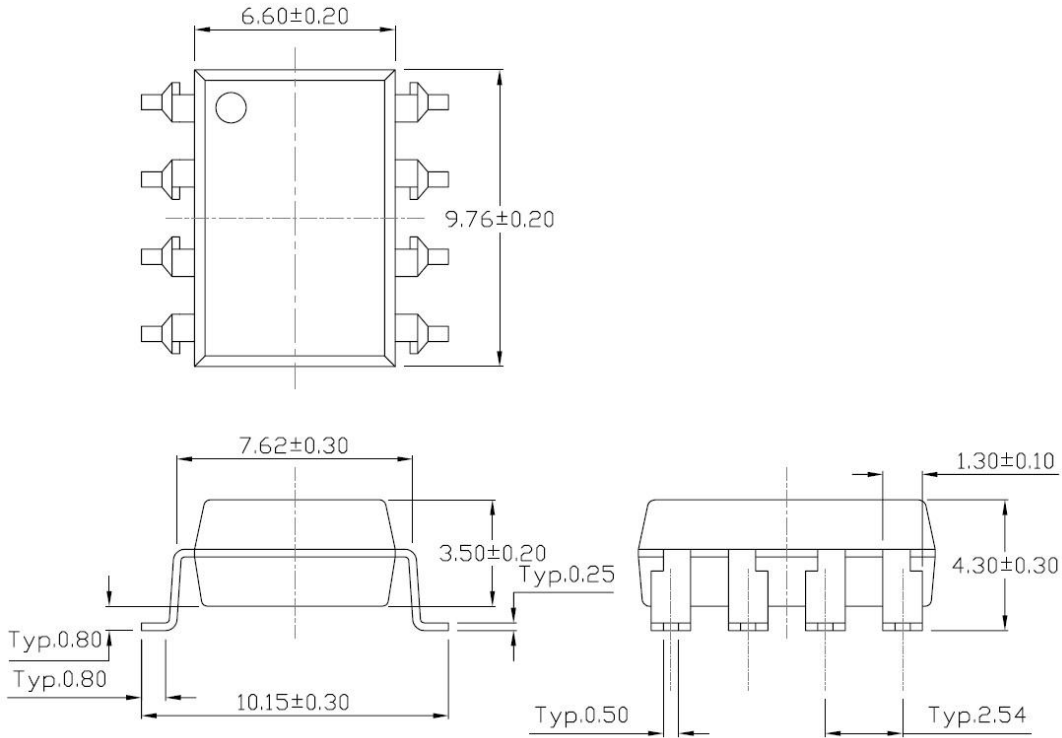

Surface Mount (Low Profile) Lead Forming (SL Type)

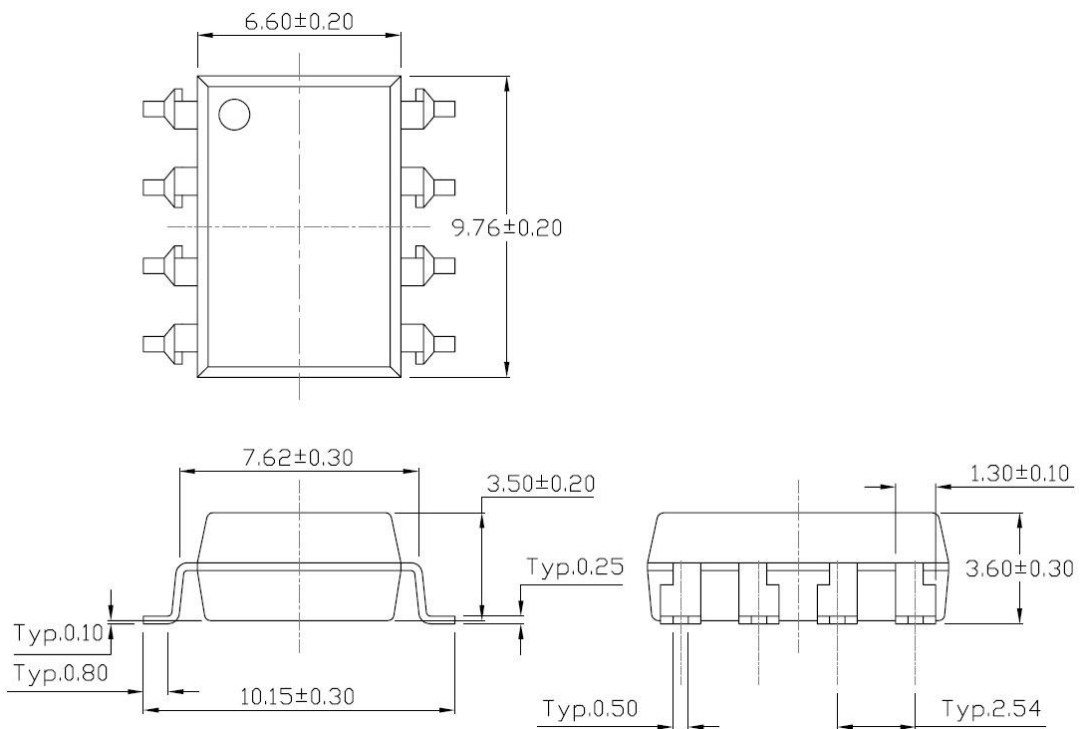

PACKAGE DIMENSIONS (Dimensions in mm unless otherwise stated)

Surface Mount (Gullwing) Lead Forming (SLM Type)

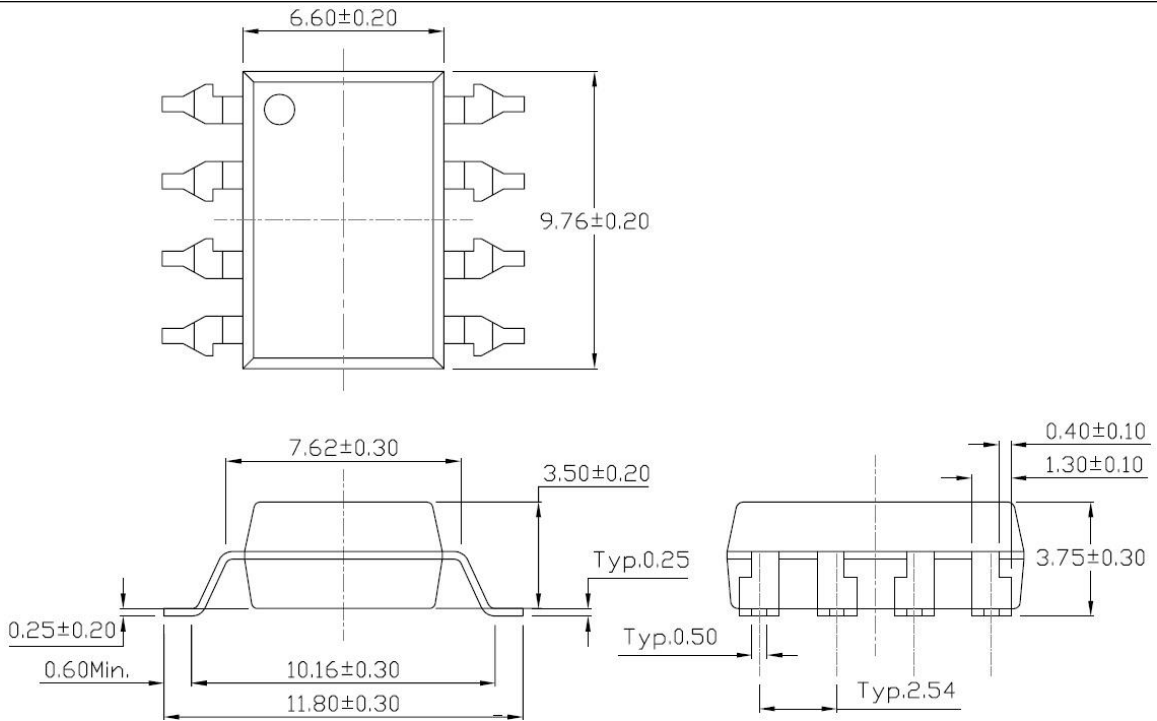

Recommended Solder Mask (Dimensions in mm unless otherwise stated)

Surface Mount Lead Forming & Surface Mount (Low Profile) Lead Forming

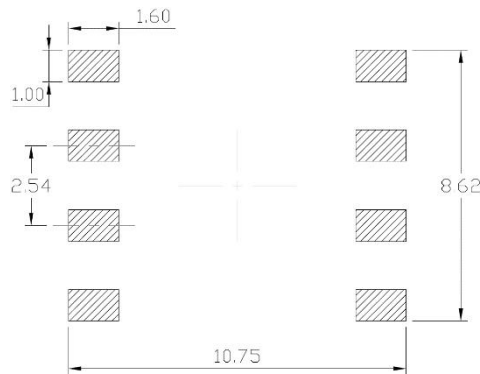

Surface Mount (Gullwing) Lead Forming

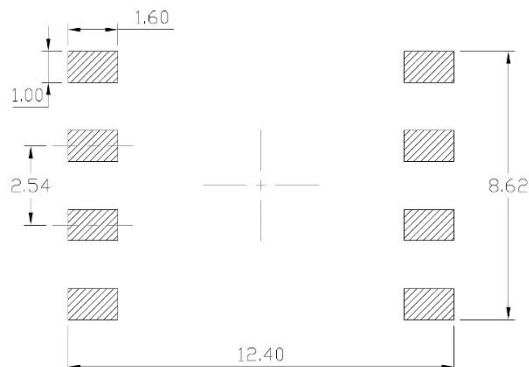

Carrier Tape Specifications (Dimensions in mm unless otherwise stated)

Option S(T1) & SL(T1)

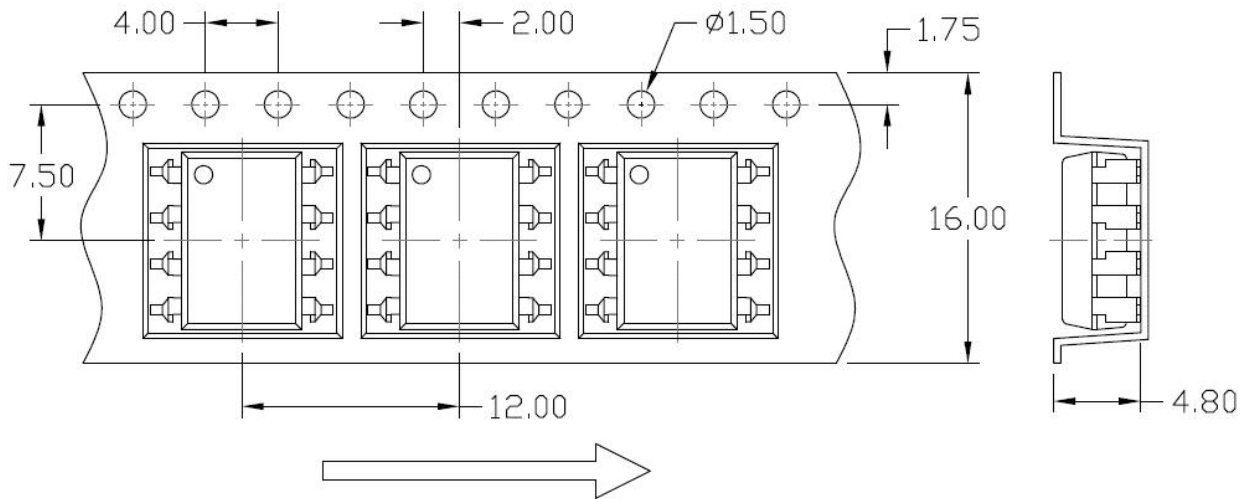

Option S(T2) & SL(T2)

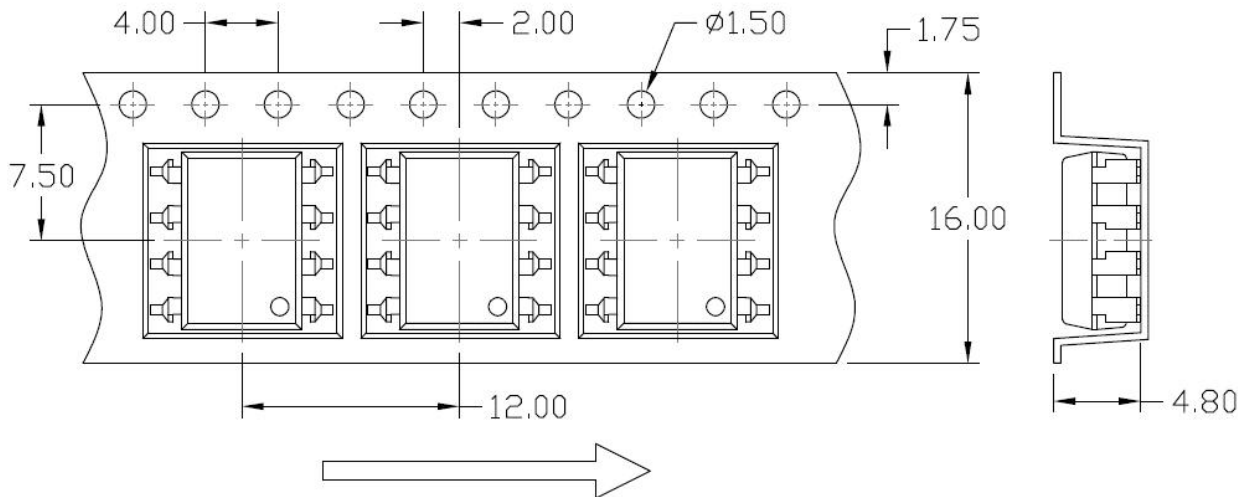

Carrier Tape Specifications (Dimensions in mm unless otherwise stated)

Option SLM(T1)

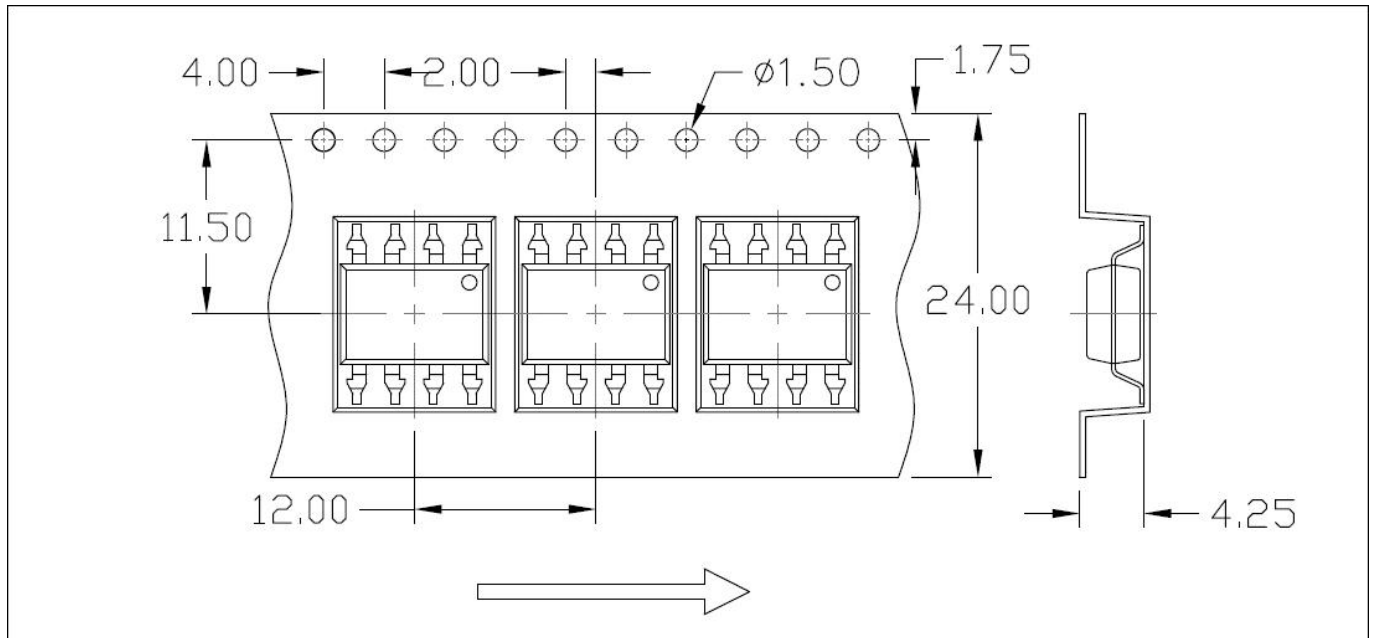

Option SLM(T2)

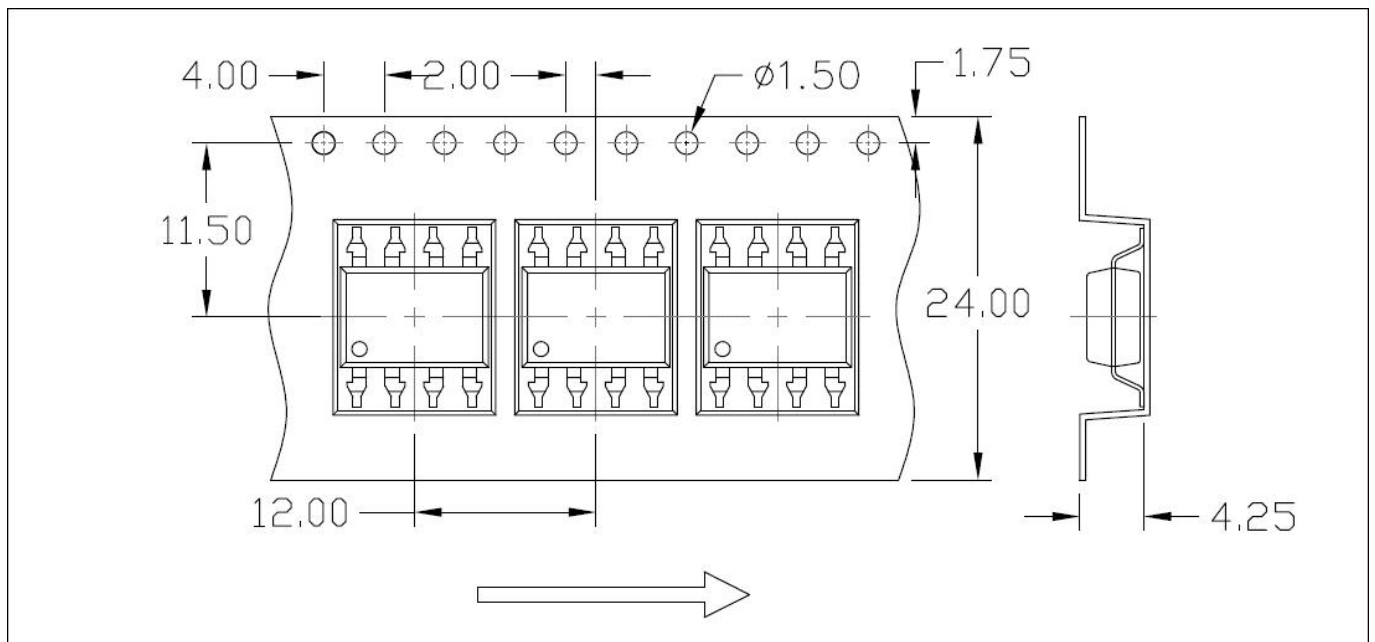

REFLOW INFORMATION

REFLOW PROFILE

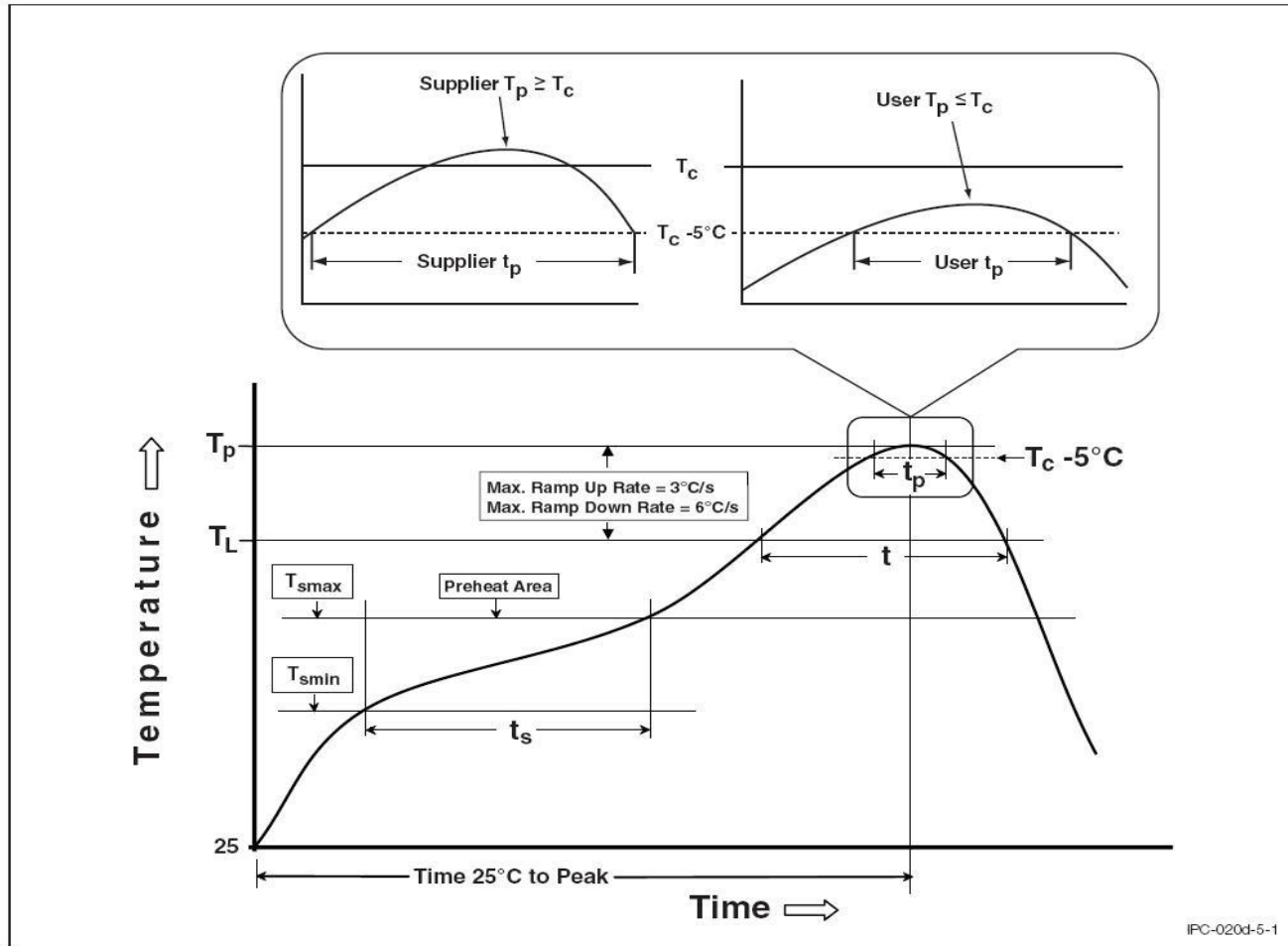

Profile Feature	Sn-Pb Assembly Profile	Pb-Free Assembly Profile
Temperature Min. (Tsmmin)	100	150°C
Temperature Max. (Tsmmax)	150	200°C
Time (ts) from (Tsmmin to Tsmmax)	60-120 seconds	60-120 seconds
Ramp-up Rate (tL to tP)	3°C/second max.	3°C/second max.
Liquidous Temperature (TL)	183°C	217°C
Time (tL) Maintained Above (TL)	60 – 150 seconds	60 – 150 seconds
Peak Body Package Temperature	235°C +0°C / -5°C	260°C +0°C / -5°C
Time (tP) within 5°C of 260°C	20 seconds	30 seconds
Ramp-down Rate (TP to TL)	6°C/second max	6°C/second max
Time 25°C to Peak Temperature	6 minutes max.	8 minutes max.

Looking for pricing, stock, or lifecycle information?

Click below to explore more details on WIN SOURCE:

- [View 6N136S on WIN SOURCE](#)
- [ShenZhen Silkormicro Semicon Co. Ltd Information](#)

Optimize Your Supply Chain with WIN SOURCE Solutions

- ✓ Global Sourcing Solution
- ✓ Obsolete Management
- ✓ Cost Control Management
- ✓ Shortage Management
- ✓ Alternative Solution
- ✓ Excess Inventory Management