



# THE DATASHEET OF LM2902



## LOW POWER QUAD OPERATIONAL AMPLIFIER

- WIDE GAIN BANDWIDTH: 1.3MHz
- INPUT COMMON-MODE VOLTAGE RANGE INCLUDES GROUND
- LARGE VOLTAGE GAIN: 100dB
- VERY LOW SUPPLY CURRENT/AMPLI: 375µA
- LOW INPUT BIAS CURRENT: 20nA
- LOW INPUT OFFSET CURRENT: 2nA
- WIDE POWER SUPPLY RANGE:  
SINGLE SUPPLY: +3V TO +30V  
DUAL SUPPLIES: ±1.5V TO ±15V

### DESCRIPTION

This circuit consists of four independent, high gain, internally frequency compensated operational amplifiers which were designed specially for automotive and industrial control systems. It operates from a single power supply over a wide range of voltages. Operation from split power supplies is also possible and the low power supply current drain is independent of the magnitude of the power supply voltage.

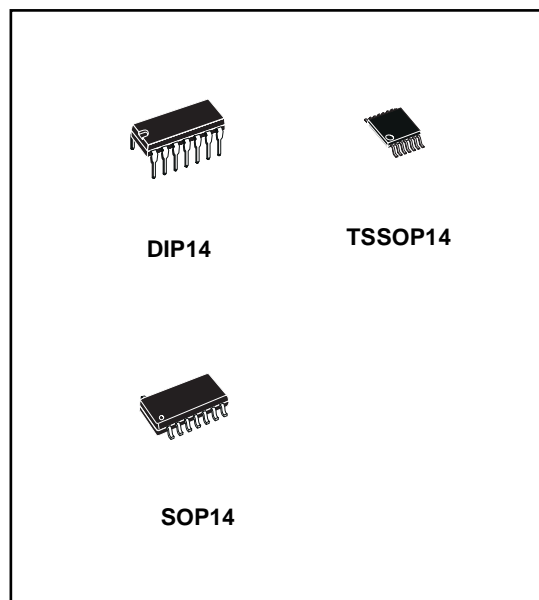

### ORDERING INFORMATION

DEVICE	Package Type	MARKING	Packing	Packing Qty
LM2902N	DIP14	LM2902	TUBE	1000/box
LM2902	SOP14	LM2902	REEL	2500/reel
LM2902P	TSSOP14	LM2902	REEL	2500/reel

### PIN CONNECTIONS (top view)

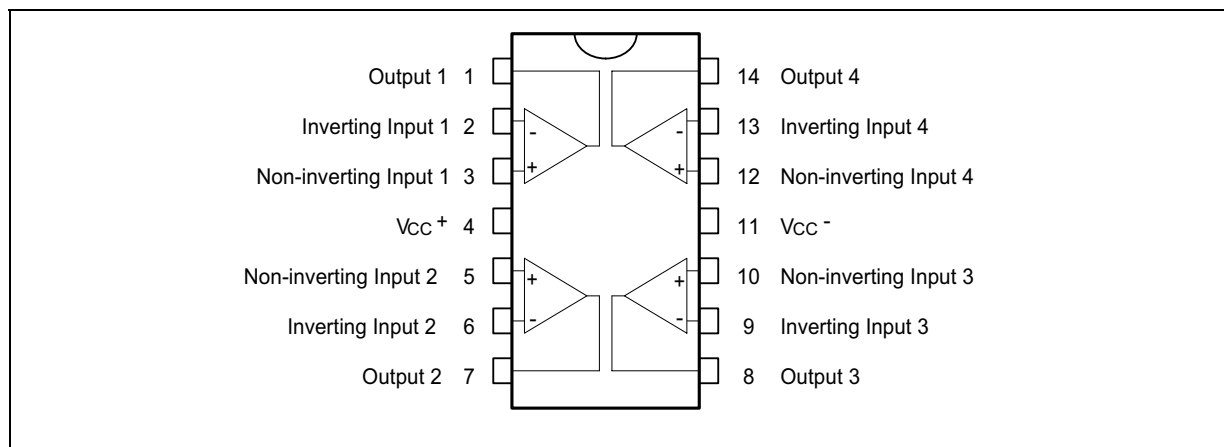

## SCHEMATIC DIAGRAM (1/4 LM2902)

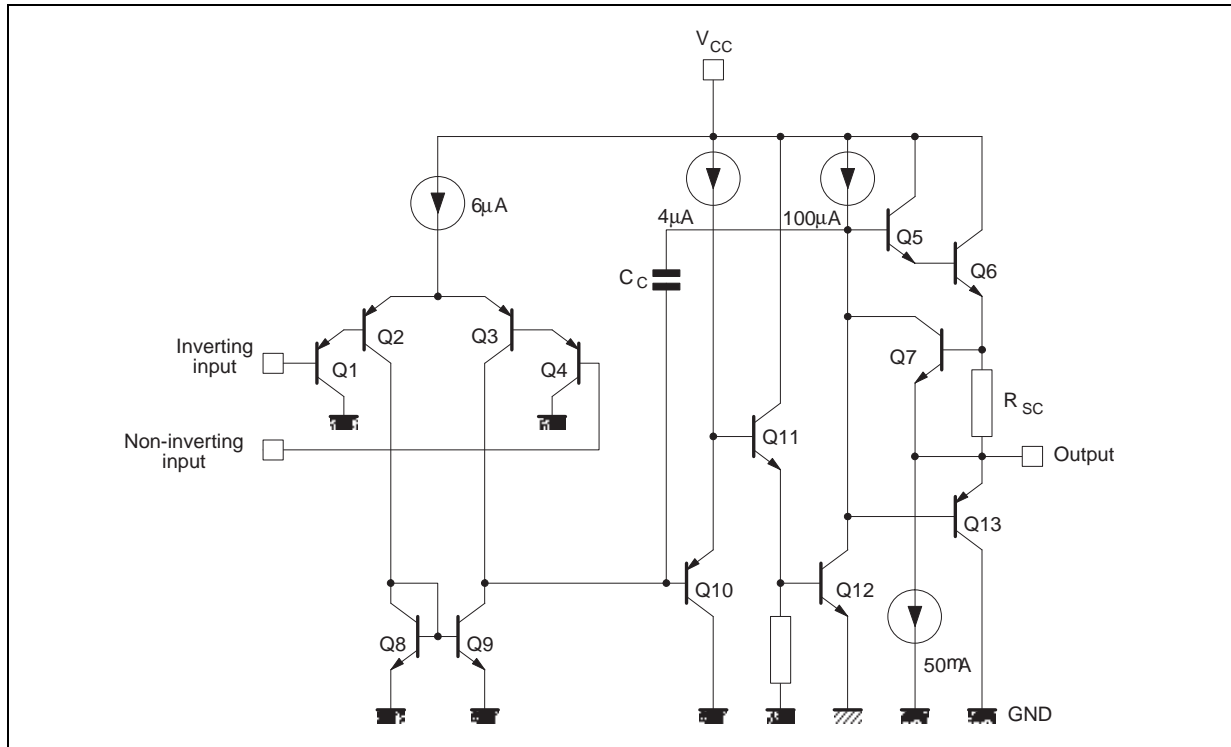

## ABSOLUTE MAXIMUM RATINGS

Symbol	Parameter	Value	Unit
$V_{CC}$	Supply Voltage	$\pm 16$ to 32	V
$V_{id}$	Differential Input Voltage	+32	V
$V_I$	Input Voltage	-0.3 to +32	V
	Output Short-circuit to Ground <sup>1)</sup>	Infinite	
$P_{tot}$	Power Dissipation N Suffix D Suffix	500 400	mW
$I_{in}$	Input Current <sup>2)</sup>	50	mA
$T_{oper}$	Operating Free-Air Temperature Range	-40 to +125	°C
$T_{stg}$	Storage Temperature Range	-65 to +150	°C

1. Short-circuit from the output to  $V_{CC}$  can cause excessive heating if  $V_{CC} > 15V$ . The maximum output current is approximately 40mA independent of the magnitude of  $V_{CC}$ . Destructive dissipation can result from simultaneous short-circuit on all amplifiers.

2. This input current only exists when the voltage at any of the input leads is driven negative. It is due to the collector-base junction of the input PNP transistor becoming forward biased and thereby acting as input diodes clamps. In addition to this diode action, there is also NPN parasitic action on the IC chip. This transistor action can cause the output voltages of the Op-Amps to go to the  $V_{CC}$  voltage level (or to ground for a large overdrive) for the time duration than an input is driven negative. This is not destructive and normal output will set up again for input voltage higher than -0.3V.

**ELECTRICAL CHARACTERISTICS**
 $V_{CC}^+ = 5V$ ,  $V_{CC}^- = \text{Ground}$ ,  $V_O = 1.4V$ ,  $T_{amb} = 25^\circ\text{C}$  (unless otherwise specified)

Symbol	Parameter	Min.	Typ.	Max.	Unit
$V_{io}$	Input Offset Voltage <sup>1)</sup> $T_{amb} = +25^\circ\text{C}$ $T_{min} \leq T_{amb} \leq T_{max.}$		2	7 9	mV
$I_{io}$	Input Offset Current $T_{amb} = +25^\circ\text{C}$ $T_{min} \leq T_{amb} \leq T_{max.}$		2	30 40	nA
$I_{ib}$	Input Bias Current <sup>2)</sup> $T_{amb} = +25^\circ\text{C}$ $T_{min} \leq T_{amb} \leq T_{max.}$		20	150 300	nA
$A_{vd}$	Large Signal Voltage Gain $V_{CC}^+ = +15V, R_L = 2k\Omega$ , $V_O = 1.4V$ to $11.4V$ $T_{amb} = +25^\circ\text{C}$ $T_{min} \leq T_{amb} \leq T_{max.}$	50 25	100		V/mV
SVR	Supply Voltage Rejection Ratio ( $R_S \leq 10k\Omega$ ) $T_{amb} = +25^\circ\text{C}$ $T_{min} \leq T_{amb} \leq T_{max.}$	65 65	110		dB
$I_{cc}$	Supply Current, all Amp, no load $T_{amb} = +25^\circ\text{C}$ $T_{min} \leq T_{amb} \leq T_{max.}$				
	$V_{CC} = +5V$		0.7	1.2	mA
	$V_{CC} = +30V$		1.5	3	
	$V_{CC} = +5V$		0.8	1.2	
	$V_{CC} = +30V$		1.5	3	
$V_{icm}$	Input Common Mode Voltage Range ( $V_{CC} = +30V$ ) <sup>3)</sup> $T_{amb} = +25^\circ\text{C}$ $T_{min} \leq T_{amb} \leq T_{max.}$	0 0		$V_{CC} - 1.5$ $V_{CC} - 2$	V
CMR	Common-mode Rejection Ratio ( $R_S \leq 10k\Omega$ ) $T_{amb} = +25^\circ\text{C}$ $T_{min} \leq T_{amb} \leq T_{max.}$	70 60	80		dB
$I_O$	Output Short-circuit Current ( $V_{id} = +1V$ ) $V_{CC} = +15V$ , $V_O = +2V$	20	40	70	mA
$I_{sink}$	Output Sink Current ( $V_{id} = -1V$ ) $V_{CC} = +15V$ , $V_O = +2V$ $V_{CC} = +15V$ , $V_O = +0.2V$	10 12	20 50		mA $\mu\text{A}$
$V_{OH}$	High Level Output Voltage ( $V_{CC} = +30V$ ) $T_{amb} = +25^\circ\text{C}$ $R_L = 2k\Omega$ $T_{min} \leq T_{amb} \leq T_{max.}$ $T_{amb} = +25^\circ\text{C}$ $R_L = 10k\Omega$ $T_{min} \leq T_{amb} \leq T_{max.}$ ( $V_{CC} + 5V$ ), $R_L = 2k\Omega$ $T_{min} \leq T_{amb} \leq T_{max.}$ $T_{amb} = +25^\circ\text{C}$	26 26 27 27 3.5 3	27 28		V
$V_{OL}$	Low Level Output Voltage ( $R_L = 10k\Omega$ ) $T_{amb} = +25^\circ\text{C}$ $T_{min} \leq T_{amb} \leq T_{max.}$		5	20 20	mV
SR	Slew Rate $V_{CC} = 15V$ , $V_i = 0.5$ to $3V$ , $R_L = 2k\Omega$ , $C_L = 100pF$ , unity gain		0.4		V/ $\mu\text{s}$

Symbol	Parameter	Min.	Typ.	Max.	Unit
GBP	Gain Bandwidth Product $V_{cc} = 30V, V_{in} = 10mV, R_L = 2k\Omega, C_L = 100pF$		1.3		MHz
THD	Total Harmonic Distortion $f = 1kHz, A_V = 20dB, R_L = 2k\Omega, V_o = 2V_{pp}, C_L = 100pF, V_{cc} = 30V$		0.015		%
$e_n$	Equivalent Input Noise Voltage $f = 1kHz, R_S = 100\Omega, V_{cc} = 30V$		40		$\frac{nV}{\sqrt{Hz}}$
$DV_{io}$	Input Offset Voltage Drift		7	30	$\mu V/^\circ C$
$DI_{io}$	Input Offset Current Drift		10	200	$pA/^\circ C$
$V_{O1}/V_{O2}$	Channel Separation <sup>4)</sup> $1kHz \leq f \leq 20kHz$		120		dB

- $V_O = 1.4V, R_S = 0\Omega, 5V < V_{CC}^+ < 30V, 0V < V_{IC} < V_{CC}^+ - 1.5V$
- The direction of the input current is out of the IC. This current is essentially constant, independent of the state of the output, so no loading charge change exists on the input lines
- The input common-mode voltage of either input signal voltage should not be allowed to go negative by more than 0.3V. The upper end of the common-mode voltage range is  $V_{CC}^+ - 1.5V$ , but either or both inputs can go to +32V without damage.
- Due to the proximity of external components insure that coupling is not originating via stray capacitance between these external parts. This typically can be detected as this type of capacitance increases at higher frequencies.

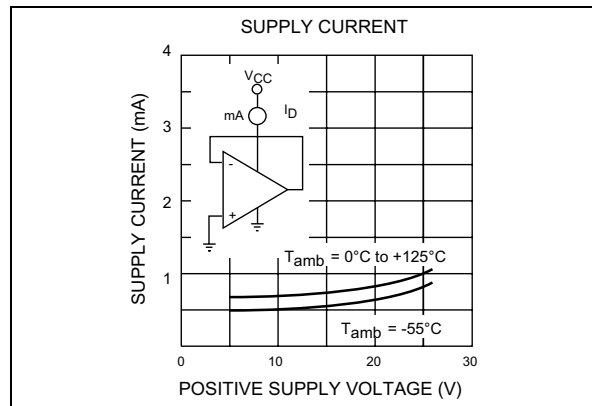
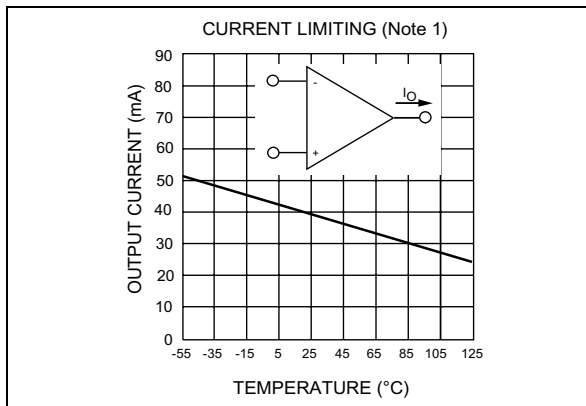
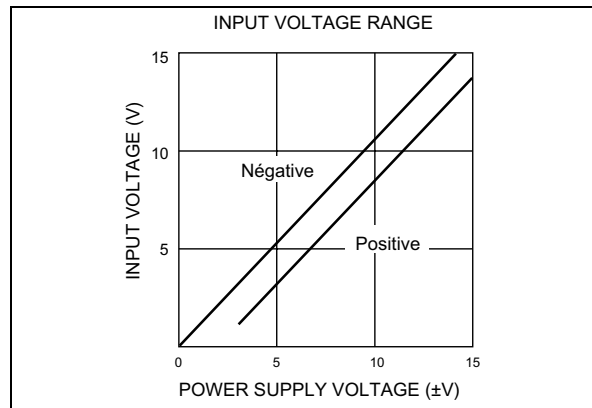
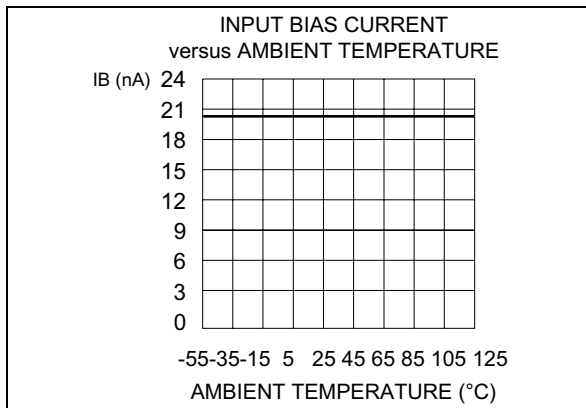

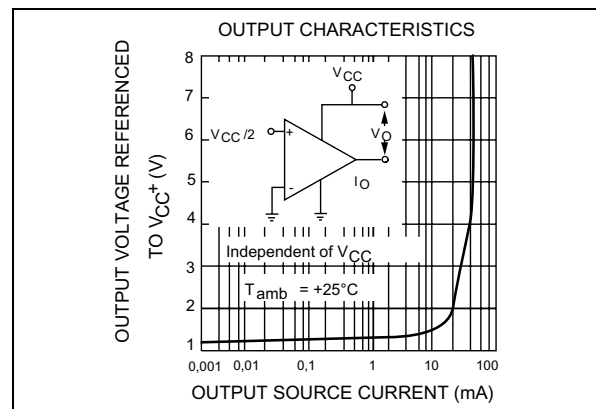
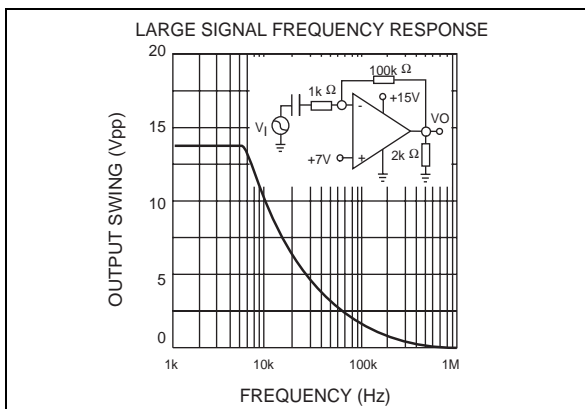
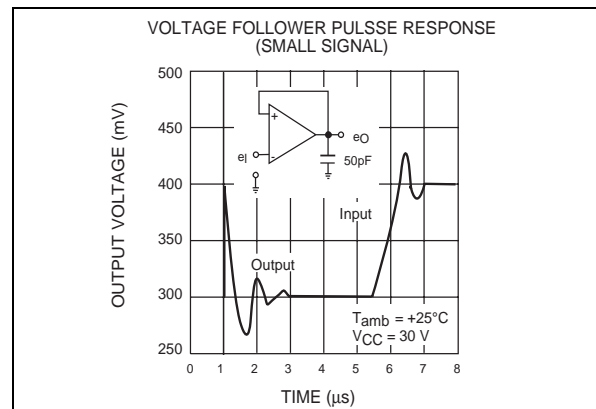
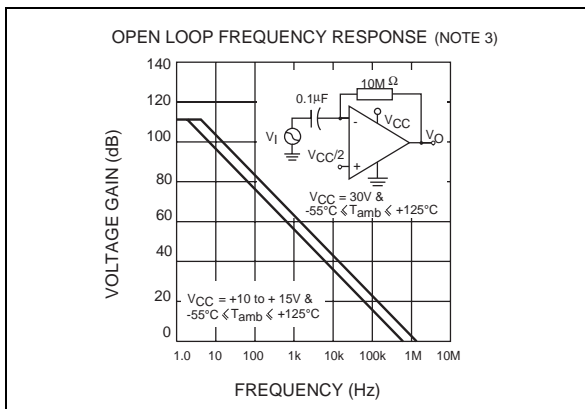
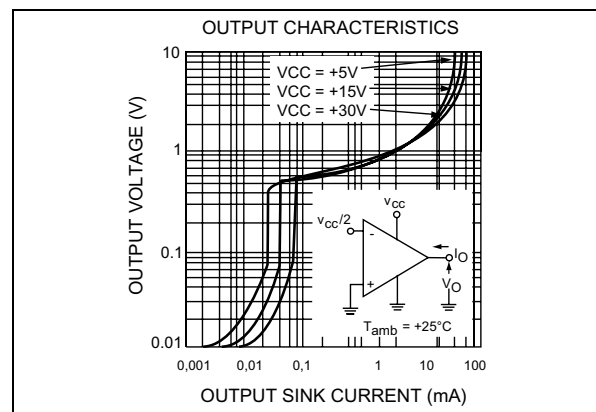
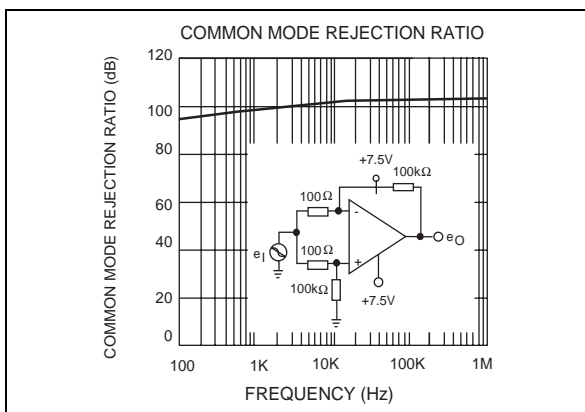
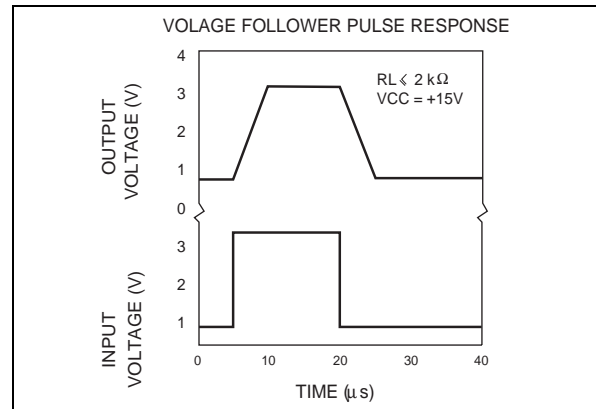
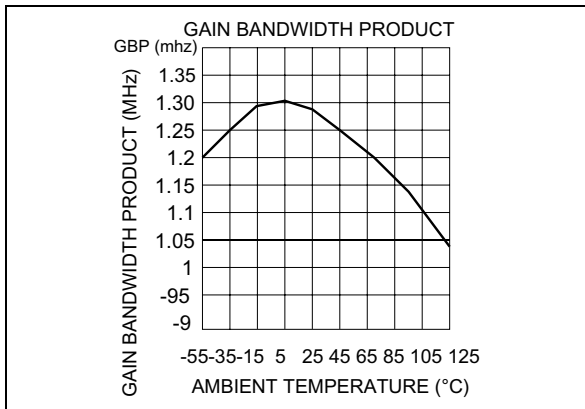

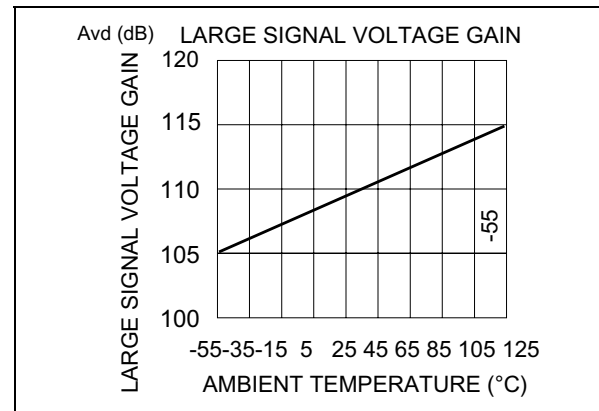
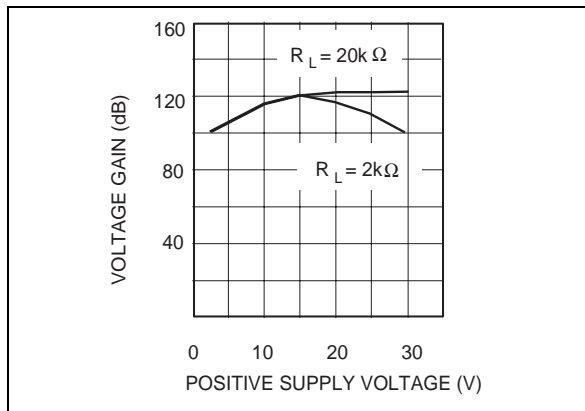
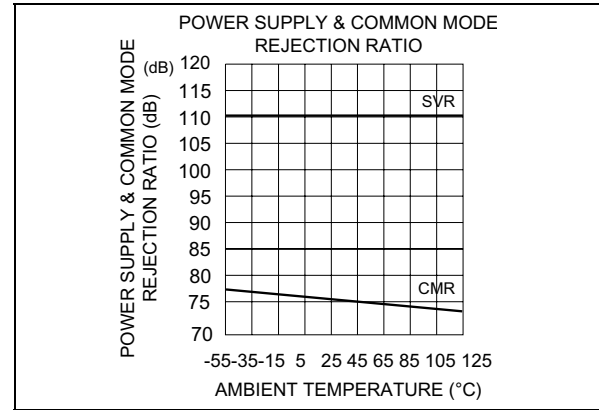
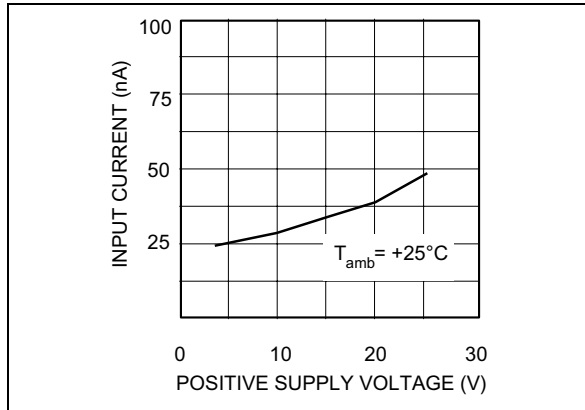

## TYPICAL SINGLE - SUPPLY APPLICATIONS

### AC COUPLED INVERTING AMPLIFIER

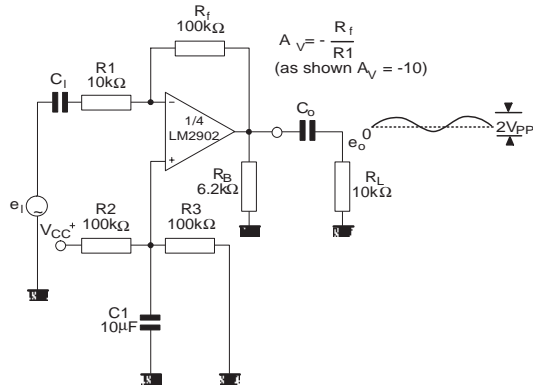

### NON-INVERTING DC GAIN

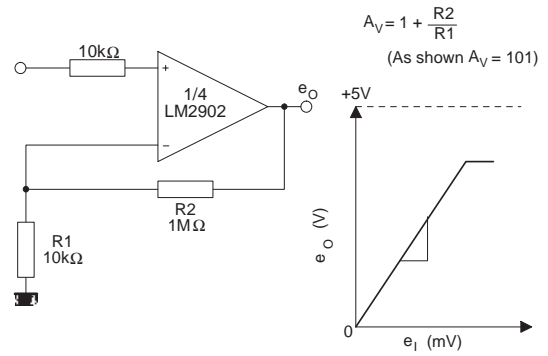

### AC COUPLED NON-INVERTING AMPLIFIER

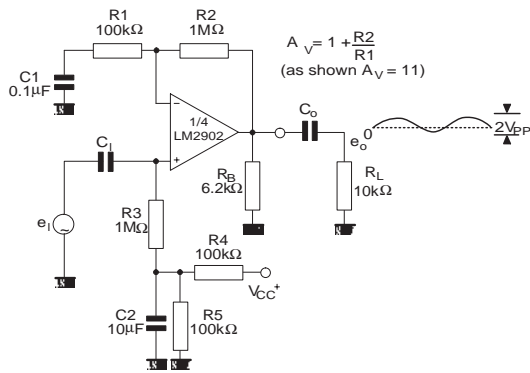

### DC SUMMING AMPLIFIER

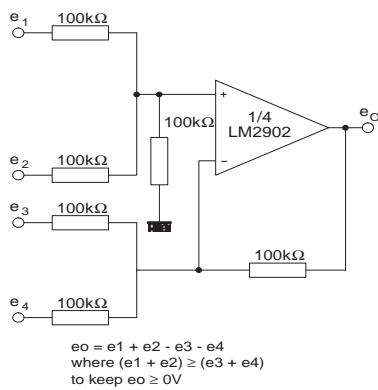

### ACTIVER BADPASS FILTER

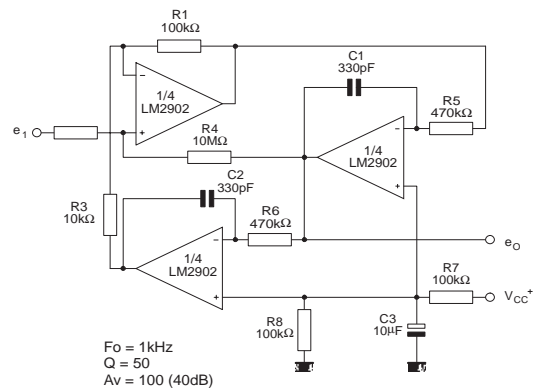

## HIGH INPUT Z ADJUSTABLE GAIN DC INSTRUMENTATION AMPLIFIER

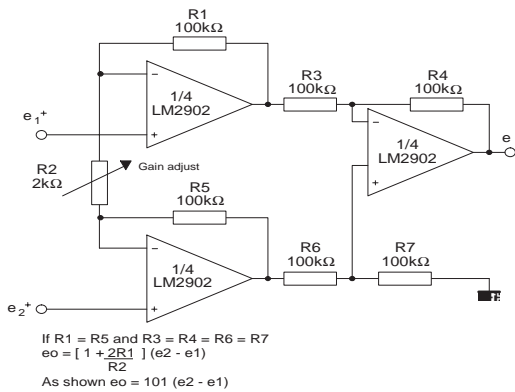

## HIGH INPUT Z, DC DIFFERENTIAL AMPLIFIER

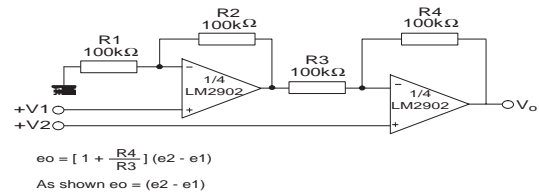

## LOW DRIFT PEAK DETECTOR

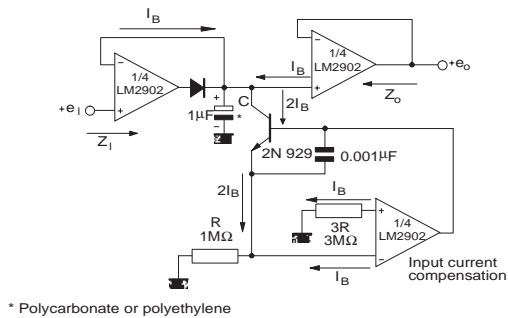

## USING SYMMETRICAL AMPLIFIERS TO REDUCE INPUT CURRENT (GENERAL CONCEPT)

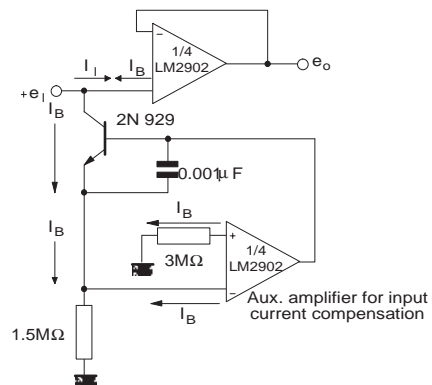

## SOP14

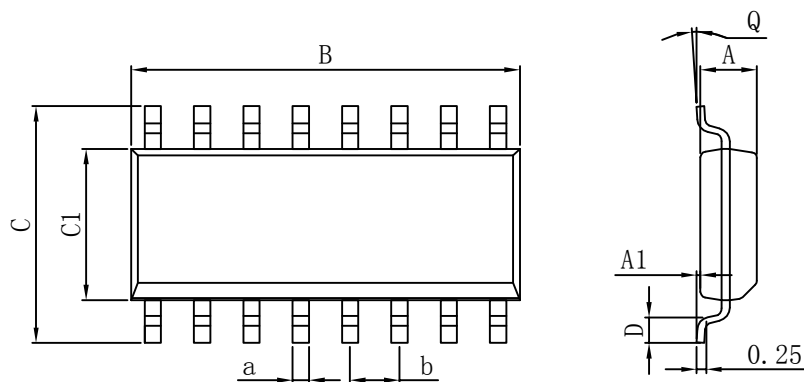

Dimensions In Millimeters					
Symbol :	Min :	Max :	Symbol :	Min :	Max :
A	4.520	4.620	D	0.400	0.950
A1	0.100	0.250	Q	0°	8°
B	8.500	9.000	a	0.420 TYP	
C	5.800	6.250	b	1.270 TYP	
C1	3.800	4.000			

## DIP14

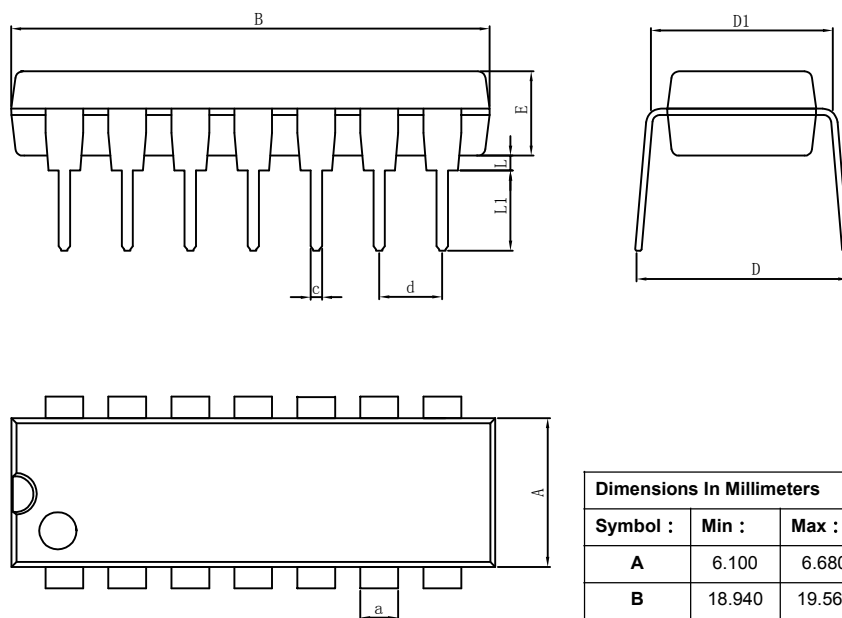

Dimensions In Millimeters					
Symbol :	Min :	Max :	Symbol :	Min :	Max :
A	6.100	6.680	L	0.500	0.800
B	18.940	19.560	L1	3.000	3.600
D	8.200	9.200	a	1.524 TYP	
D1	7.42	7.820	c	0.457 TYP	
E	3.100	3.550	d	2.540 TYP	

TSSOP14

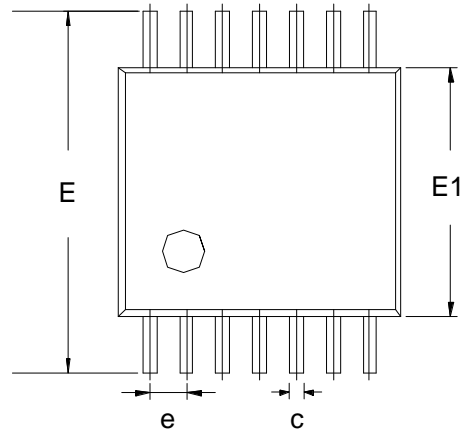
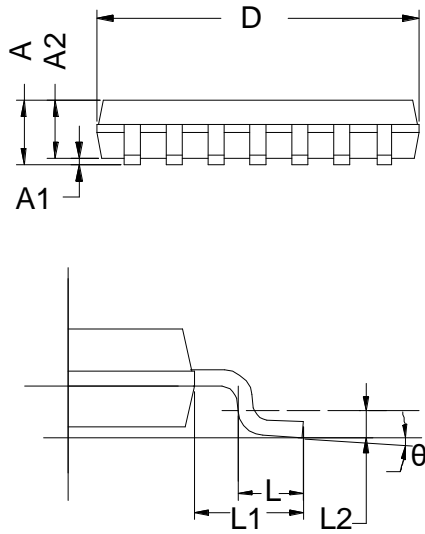

Dimensions In Millimeters

Symbol :	Min :	Max :	Symbol :	Min :	Max :
A	0.950	1.200	E1	4.300	4.500
A1	0.050	0.150	L	0.450	0.750
A2	0.900	1.050	$\theta$	0°	8°
B	0.200	0.280	e	0.650 BSC	
C	0.100	0.190	L1	1.000 REF	
D	4.860	5.060	L2	1.250 BSC	
E	6.200	6.600			

## Looking for pricing, stock, or lifecycle information?

Click below to explore more details on WIN SOURCE:

- [View LM2902 on WIN SOURCE](#)
- [ShenZhen SikorMicro Semicon Co. Ltd Information](#)

## Optimize Your Supply Chain with WIN SOURCE Solutions

- ✓ Global Sourcing Solution
- ✓ Obsolete Management
- ✓ Cost Control Management
- ✓ Shortage Management
- ✓ Alternative Solution
- ✓ Excess Inventory Management