



THE DATASHEET OF LM224D



QUADRUPLE OPERATIONAL AMPLIFIERS

- **Wide Range of Supply Voltages:**
Single Supply...3V to 30V
(LM2902 and LM2902Q 3V to 26V), or Dual Supplies
- **Low Supply Current Drain Independent of Supply Voltage ...0.8mA Typ**
- **Common-Mode Input Voltage Range Includes Ground Allowing Direct Sensing Near Ground**
- **Low Input Bias and Offset Parameters:**
Input Offset Voltage ... 3mV Typ
A Versions... 2 mV Typ
Input Offset Current ... 2nA Typ
Input Bias Current ... 20nA Typ
A Versions ... 15nA Typ
- **Differential Input Voltage Range Equal to Maximum-Rated Supply Voltage... 32V (26V for LM2902 and LM2902Q)**
- **Open-Loop Differential Voltage Amplification ... 100V/mV Typ**
- **Internal Frequency Compensation**

Description

These devices consist of four independent high-gain frequency-compensated operational amplifiers that are designed specifically to operate from a single supply over a wide range of voltages. Operation from split supplies is also possible when the difference between the two supplies is 3V to 30V (for the LM2902 and LM2902Q, 3V to 26V) and Vcc is at least 1.5V more positive than the input common-mode voltage. The low supply current drain is independent of the magnitude of the supply voltage.

Applications include transducer amplifiers, dc amplification blocks, and all the conventional operational amplifier circuits that now can be more easily implemented in single-supply-voltage systems. For example, the LM124 can be operated directly from the standard 5-V supply that is used in digital systems and easily provides the required interface electronics without requiring additional ± 15 -V supplies.

The LM2902Q is manufactured to demanding automotive requirements.

The LM124 and LM124A are characterized for operation over the full military temperature range of -55 to 125 . The LM224 and LM224A are characterized for operation from -25 to 85 . The LM324 and LM324A are characterized for operation from 0 to 70 . The LM2902 and LM2902Q are characterized for operation from -40 to 125 .

LM124,LM124A ... J OR W PACKAGE
ALL OTHERS ... D, DB, N OR PW PACKAGE
(TOP VIEW)

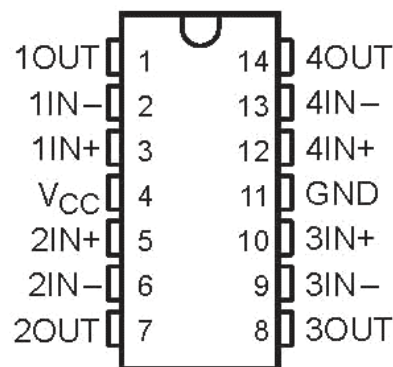

LM124,LM124A ...FK PACKAGE
(TOP VIEW)

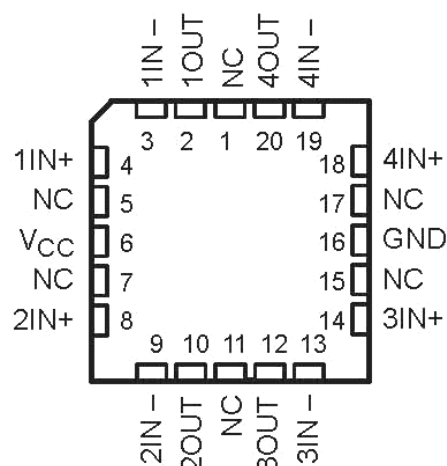

NC-No internal connection

Symbol (each amplifier)

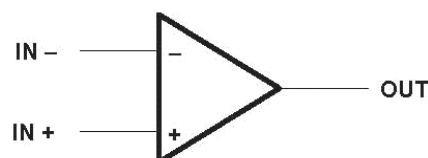

AVAILABLE OPTIONS

TA	V _{I0max} AT 25	PACKAGED DEVICES							CHIP FORM (Y)
		SMALL OUTLINE (D) †	VERY SMALL OUTLINE (DB) ‡	CHIP CARRIER (FK)	CERAMIC DIP (J)	PLASTIC DIP (N)	TSSOP (PW) †	FLAT PACK (W)	
0 to 70	7 mV 3mV	LM324D	LM324DBLE	-	-	LM324N	LM324PWLE	-	LM324Y
		LM324AD	-	-	-	LM324AN	LM324APWLE	-	
-25 to 85	5mV 3mV	LM224D	-	-	-	LM224N	-	-	-
		LM224AD	-	-	-	LM224AN	-	-	-
-40 to 125	7mV	LM2902D	LM2902DBLE	-	-	LM2902N	LM2902PWLE	-	-
		LM2902QD	-	-	-	LM2902QN	-	-	-
-55 to 125	5mV 2mV	-	-	LM124FK	LM124J	-	-	LM124W	-
		-	-	LM124AFK	LM124AJ	-	-		

† The D package is available taped and reeled. Add the suffix R to the device type (e.g., LM324DR).

‡ The DB and PW package are only available left-end taped and reeled.

Schematic (each amplifier)

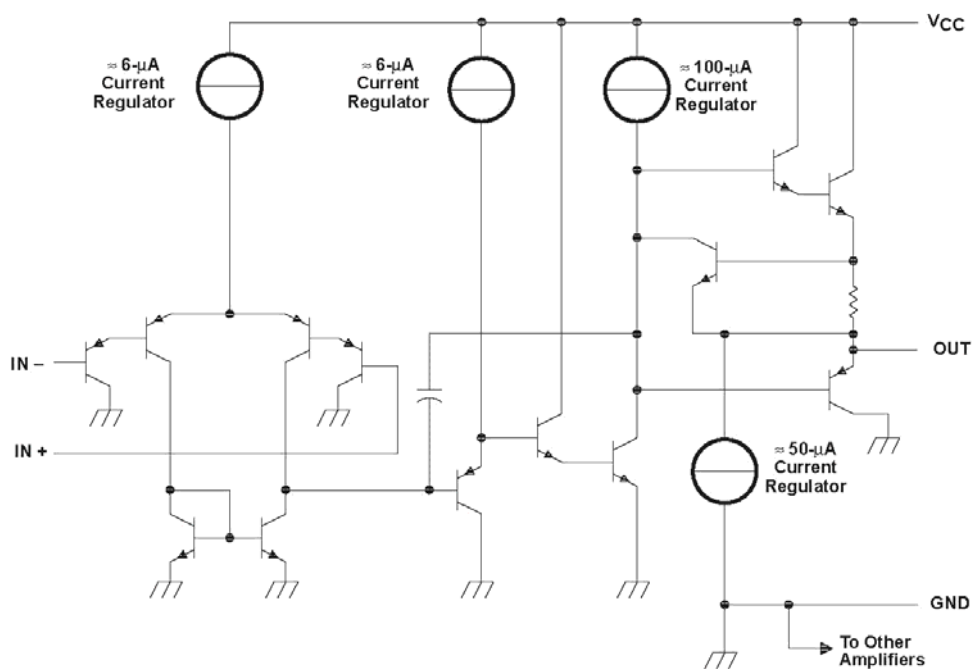

COMPONENT COUNT (total device)	
Epi-FET	1
Transistors	95
Diodes	4
Resistors	11
Capacitors	4

LM324Y chip information

This chip, when properly assembled, displays characteristics similar to the LM324. Thermal compression or ultrasonic bonding may be used on the doped-aluminum bonding pads. Chips may be mounted with conductive epoxy or a gold-silicon perform.

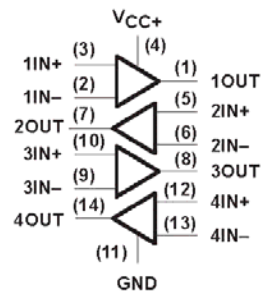
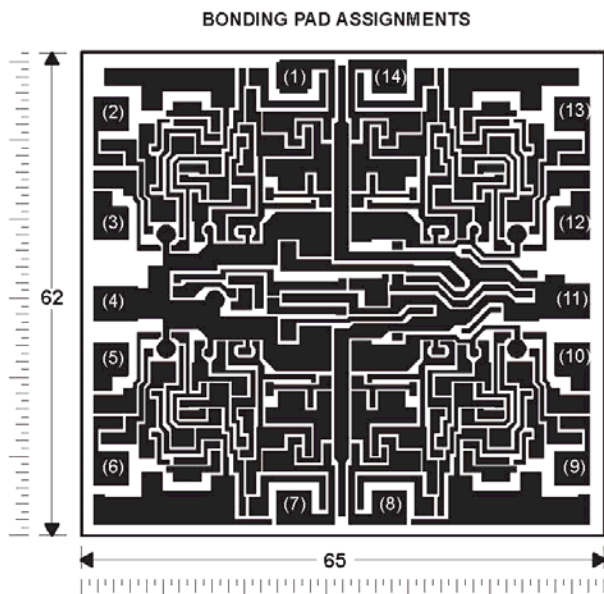

CHIP THICKNESS: 15 TYPICAL

BONDING PADS: 4 × 4 MINIMUM

$T_{jmax} = 150^{\circ}C$

TOLERANCES ARE $\pm 10\%$.

ALL DIMENSIONS ARE IN MILS.

PIN (11) IS INTERNALLY CONNECTED TO BACKSIDE OF CHIP.



LM124 -- LM2902Q

Absolute maximum ratings over operating free-air temperature range (unless otherwise noted) †

	LM124,LM124A LM224,LM224A LM324,LM324A	LM2902, LM2902Q	UNIT
Supply voltage, V_{CC} (see Note 1)	32	26	V
Differential input voltage, V_{ID} (see Note 2)	± 32	± 26	V
Input voltage, V_I (either input)	-0.3 to 32	-0.3 to 26	V
Duration of output short circuit (one amplifier) to ground at (or below) $T_A=25^\circ\text{C}$, $V_{CC}\leq 15\text{V}$ (see Note 3)	unlimited	unlimited	
Continuous total dissipation	See Dissipation Rating Table		
Operating free-air temperature range, T_A	LM124,LM124A	-55 to 125	
	LM224,LM224A	-25 to 85	
	LM324,LM324A	0 to 70	
	LM2902,LM2902Q		-40 to 125
Storage temperature range	-65 to 150	-65 to 150	
Case temperature for 60 seconds	FK package	260	
Lead temperature 1,6mm (1/16 inch) from case for 60 seconds	J or W package	300	300
Lead temperature 1,6mm (1/16 inch) from case for 10 seconds	D,DB,N, or PW package	260	260

†Stresses beyond those listed under “absolute maximum ratings” may cause permanent damage to the device. These are stress ratings only, and functional operation of the device at these or any other conditions beyond those indicated under “recommended operating conditions” is not implied. Exposure to absolute-maximum –rated conditions for extended periods may affect device reliability.

NOTES:

1. All voltage values (except differential voltages and V_{CC} specified for the measurement of I_{OS}) are with respect to the network GND.
2. Differential voltages are at $IN+$ with respect to $IN-$.
3. Short circuits from outputs to V_{CC} can cause excessive heating and eventual destruction.

DISSIPATION RATING TABLE

PACKAGE	$T_A\leq 25$ POWER RATING	DERATING FACTOR	DERATE ABOVE T_A	$T_A=70$ POWER RATING	$T_A=85$ POWER RATING	$T_A=125$ POWER RATING
D	900mW	7.6 mW/	32	611mW	497 mW	N/A
DB	775mW	6.2mW/	25	496mW	403 mW	N/A
FK	900mW	11.0mW/	68	878mW	713 mW	273 mW
J(LM124_)	900mW	11.0mW/	68	878mW	713 mW	273 mW
J(all others)	900mW	8.2mW/	40	654mW	531 mW	N/A
N	900mW	9.2mW/	52	734mW	596 mW	N/A
PW	700mW	5.6mW/	25	448mW	364 mW	N/A
W	900mW	8.0mW/	37	636mW	516 mW	196 mW

Electrical characteristics at specified free-air temperature, V_{CC}=5V (unless otherwise noted)

PARAMETER	TEST CONDITIONS†	T _A ‡	LM124, LM224			LM324			LM2902, LM2902Q			UNIT
			MIN	TYP§	MAX	MIN	TYP§	MAX	MIN	TYP§	MAX	
V _{IO} Input offset voltage	V _{CC} =5V to MAX, V _{IC} =V _{ICR} ^{min} , V _O =1.4V	25	3 5			3 7			3 7			mV
		Full range	7			9			10			
I _{IO} Input offset current	V _O =1.4V	25	2 30			2 50			2 50			nA
		Full range	100			150			300			
I _{IB} Input bias current	V _O =1.4V	25	-20 -150			-20 -250			-20 -250			nA
		Full range	-30			-500			-500			
V _{ICR} Common-mode input voltage range	V _{CC} =5V to MAX	25	0 to V _{CC} - 1.5V			0 to V _{CC} - 1.5V			0 to V _{CC} - 1.5V			V
		Full range	0 to V _{CC} - 2			0 to V _{CC} - 2			0 to V _{CC} - 2			
V _{OH} High-level output voltage	R _L =2 KΩ	25	V _{CC} - 1.5			V _{CC} - 1.5			V _{CC} - 1.5			V
	R _L =10 KΩ	25										
	V _{CC} =MAX, R _L =2kΩ	Full range	26			26			22			
	V _{CC} =MAX, R _L ≥10kΩ	Full range	27 28			27 28			23 24			
V _{OL} Low-level output voltage	R _L ≤10kΩ	Full range	5 20			5 20			5 20			mV
A _{VD} Large-signal differential Voltage amplification	V _{CC} =15V, V _O =1V to 11V R _L ≥2KΩ	25	50 100			25 100			100			V/mV
		Full range	25			15			15			
C _{MRR} Common-mode rejection ratio	V _{IC} =V _{ICR} ^{min}	25	70 80			65 80			50 80			dB
K _{SVR} Supply-voltage rejection ration (V _{CC} / V _{IO})		25	65 100			65 100			50 100			dB
V _{O1} /V _{O2} Crosstalk attenuation	F=1kHz to 20kHz	25	120			120			120			dB
I _O Output current	V _{CC} =15V, V _{ID} =1V, V _O =0	25	-20 -30 60			-20 -30 -60			-20 -30 -60			mA
		Full range	-10			-10			-10			
	V _{CC} =15V, V _{ID} =-1V, V _O =15V	25	10 20			10 20			10 20			μA
		Full range	5			5			5			
I _{OS} Short-circuit output current	V _{CC} at 5V V _O =0 GND at -5V	25	±40 ±60			±40 ±60			±40 ±60			mA
		Full range										
I _{CC} Supply current (four amplifiers)	V _O =2.5V, No load	Full range	0.7 1.2			0.7 1.2			0.7 1.2			mA
	V _{CC} =MAX, V _O =0.5 V _{CC} , No load	Full range	1.4 3			1.4 3			1.4 3			

†All characteristics are measured under open-loop conditions with zero common-mode input voltage unless otherwise specified. MAX V_{CC} for testing purposes is 26V for LM2902 and LM2902Q, 30V for the others.

‡ Full range is -55 to 125 for LM124, -25 to 85 for LM224, 0 to 70 for LM324, and -40 to 125 for LM2902 and LM2902Q.

§All typical values are at T_A=25 .



LM124 -- LM2902Q

Electrical characteristics at specified free-air temperature, Vcc=5V (unless otherwise noted)

PARAMETER	TEST CONDITIONS†	T _A ‡	LM124A			LM224A			LM324A			UNIT
			MIN	TYP§	MAX	MIN	TYP§	MAX	MIN	TYP§	MAX	
V _{IO} Input offset voltage	V _{CC} =5V to MAX, V _{IC} =V _{ICRmin} , V _O =1.4V	25			2	2	3		2	3	mV	
		Full range			4		4		5			
I _{IO} Input offset current	V _O =1.4V	25			10		1	15	2	30	nA	
		Full range			30		30		75			
I _{IB} Input bias current	V _O =1.4V	25			-50	-15	-80		-15	-100	nA	
		Full range			-100		-100		-200			
V _{ICR} Common-mode input voltage range	V _{CC} =30V	25	0 to V _{CC} - 1.5V		0 to V _{CC} - 1.5V		0 to V _{CC} - 1.5V		0 to V _{CC} - 1.5V		V	
		Full range	0 to V _{CC} -2		0 to V _{CC} -2		0 to V _{CC} -2					
V _{OH} High-level output voltage	R _L =2 KΩ	25	V _{CC} - 1.5			V _{CC} - 1.5			V _{CC} - 1.5			V
	V _{CC} =30V, R _L =2kΩ	Full range	26			26			26			
	V _{CC} =30V, R _L ≥10kΩ	Full range	27			27 28			27 28			
V _{OL} Low-level output voltage	R _L ≤10kΩ	Full range	20			5 20			5 20			mV
A _{VD} Large-signal differential Voltage amplification	V _{CC} =15V, V _O =1V to 11V R _L ≥2KΩ	Full range	25			25			15			V/mV
C _{MRR} Common-mode rejection ratio	V _{IC} =V _{ICRmin}	25	70			70 80			65 80			dB
k _{SVR} Supply-voltage rejection ration (V _{CC} / V _{IO})		25	65			65 100			65 100			dB
V01/V02 Crosstalk attenuation	f=1kHz to 20kHz	25	120			120			120			dB
I _O Output current	V _{CC} =15V, V _{ID} =1V, V _O =0	25	-20			-20 -30 -60			-20 -30 -60			mA
		Full range	-10			-10			-10			
	V _{CC} =15V, V _{ID} =-1V, V _O =15V	25	10			10 20			10 20			
		Full range	5			5			5			
VID=-1V, V _O =200mV	25	12			12 30			12 30			μA	
I _{OS} Short-circuit output current	V _{CC} at 5V GND at -5V V _O =0	25	±40 ±60			±40 ±60			±40 ±60			mA
I _{CC} Supply current (four amplifiers)	V _O =2.5V, No load	Full range	0.7 1.2			0.7 1.2			0.7 1.2			mA
	V _{CC} =30V, V _O =15V, No load	Full range	1.4 3			1.4 3			1.4 3			

† All Characteristics are measured under open-loop conditions with zero common-mode input voltage unless otherwise specified.

‡ Full range is -55 to 125 for LM124A, -25 to 85 for LM224A, and 0 to 70 for LM324A.

§ All typical values are at T_A=25 .

Electrical characteristics, V_{CC}=5V, T_A=25 (unless otherwise noted)

PARAMETER	TEST CONDITIONS†	LM324Y			UNIT
		MIN	TYP	MAX	
V _{IO} Input offset voltage	V _{CC} =5V to MAX, V _{IC} =V _{ICRmin} , V _O =1.4V		3	7	mV
I _{IO} Input offset current			2	50	nA
I _{IB} Input bias current			-20	-250	nA
V _{ICR} Common-mode input voltage range	V _{CC} =5V to MAX	0 to			V
V _{OH} High-level output voltage	R _L =10kΩ	V _{CC} -1.5			V
V _{OL} Low-level output voltage	R _L ≤10kΩ		5	20	mV
A _{VD} Large-signal differential Voltage amplification	V _{CC} =15V, V _O =1V to 11V, R _L ≥2kΩ	15	100		V/mV
C _{MRR} Common-mode rejection ratio	V _{IC} =V _{ICRmin}	65	80		dB
k _{SVR} Supply-voltage rejection ratio (V _{CC} ± V _{IO})		65	100		dB
I _O Output current	V _{CC} =15V, V _{ID} =1V, V _O =0	-20	-30	-60	mA
	V _{CC} =15V, V _{ID} =-1V, V _O =15V	10	20		
	V _{ID} =1V, V _O =200mV	12	30		
I _{OS} Short-circuit output current	V _{CC} at 5V, GND at -5V, V _O =0		±40	±60	mA
I _{CC} Supply current (four amplifiers)	V _O =2.5V _{CC} , No load		0.7	1.2	mA
	V _{CC} =Max, V _O =0.5V _{CC} , No load		1.1	3	

†All characteristics are measured under open-loop conditions with zero common-mode input voltage unless otherwise specified. MAX V_{CC} for testing purposes is 30V.

Looking for pricing, stock, or lifecycle information?

Click below to explore more details on WIN SOURCE:

- [View LM224D on WIN SOURCE](#)
- [ShenZhen SikorMicro Semicon Co. Ltd Information](#)

Optimize Your Supply Chain with WIN SOURCE Solutions

- ✓ Global Sourcing Solution
- ✓ Obsolete Management
- ✓ Cost Control Management
- ✓ Shortage Management
- ✓ Alternative Solution
- ✓ Excess Inventory Management