



# THE DATASHEET OF BTA12-600B



## Bi-Directional Triode Thyristor

### Features

- ◆ Repetitive Peak Off-State Voltage : 600V
- ◆ R.M.S On-State Current (  $I_{T(RMS)} = 12 \text{ A}$  )
- ◆ High Commutation  $dv/dt$
- ◆ Isolation Voltage (  $V_{ISO} = 1500\text{V AC}$  )

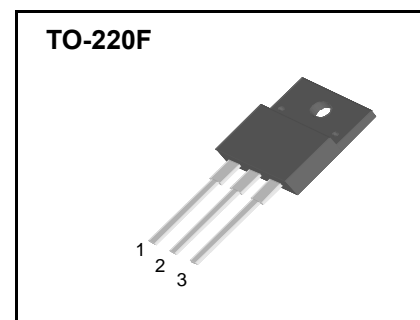
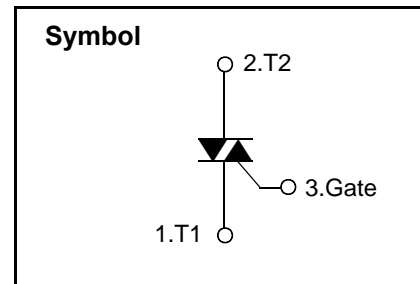

### Absolute Maximum Ratings ( $T_J = 25^\circ\text{C}$ unless otherwise specified )

Symbol	Parameter	Condition	Ratings	Units
$V_{DRM}$	Repetitive Peak Off-State Voltage		600	V
$I_{T(RMS)}$	R.M.S On-State Current	$T_C = 79^\circ\text{C}$	12	A
$I_{TSM}$	Surge On-State Current	One Cycle, 50Hz/60Hz, Peak, Non-Repetitive	119/130	A
$I^2_t$	$I^2_t$		71	$\text{A}^2\text{s}$
$P_{GM}$	Peak Gate Power Dissipation		5.0	W
$P_{G(AV)}$	Average Gate Power Dissipation		0.5	W
$I_{GM}$	Peak Gate Current		2.0	A
$V_{GM}$	Peak Gate Voltage		10	V
$V_{ISO}$	Isolation Breakdown Voltage(R.M.S.)	A.C. 1 minute	1500	V
$T_J$	Operating Junction Temperature		- 40 ~ 125	$^\circ\text{C}$
$T_{STG}$	Storage Temperature		- 40 ~ 150	$^\circ\text{C}$
	Mass		2.0	g

**Electrical Characteristics**

Symbol	Items		Conditions	Ratings			Unit
				Min.	Typ.	Max.	
$I_{DRM}$	Repetitive Peak Off-State Current		$V_D = V_{DRM}$ , Single Phase, Half Wave $T_J = 125\text{ }^\circ\text{C}$	—	—	2.0	mA
$V_{TM}$	Peak On-State Voltage		$I_T = 20\text{ A}$ , Inst. Measurement	—	—	1.4	V
$I_{GT1}^+$	I	Gate Trigger Current	$V_D = 6\text{ V}$ , $R_L = 10\text{ }\Omega$	—	—	30	mA
$I_{GT1}^-$	II			—	—	30	
$I_{GT3}^-$	III			—	—	30	
$V_{GT1}^+$	I	Gate Trigger Voltage	$V_D = 6\text{ V}$ , $R_L = 10\text{ }\Omega$	—	—	1.5	V
$V_{GT1}^-$	II			—	—	1.5	
$V_{GT3}$	III			—	—	1.5	
$V_{GD}$	Non-Trigger Gate Voltage		$T_J = 125\text{ }^\circ\text{C}$ , $V_D = 1/2 V_{DRM}$	0.2	—	—	V
$(dv/dt)_c$	Critical Rate of Rise Off-State Voltage at Commutation		$T_J = 125\text{ }^\circ\text{C}$ , $[di/dt]_c = -6.0\text{ A/ms}$ , $V_D = 2/3 V_{DRM}$	10	—	—	$V/\mu\text{s}$
$I_H$	Holding Current			—	20	—	mA
$R_{th(j-c)}$	Thermal Impedance		Junction to case	—	—	3.3	$^\circ\text{C/W}$

**Fig 1. Gate Characteristics**

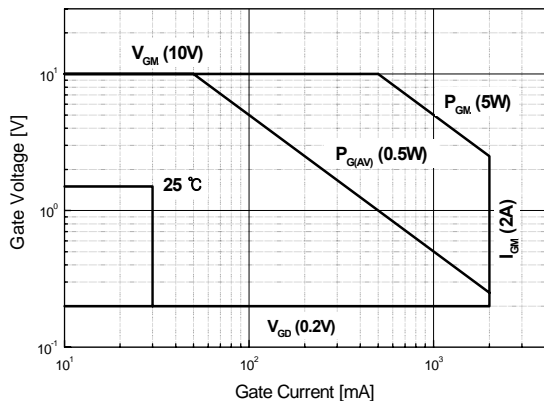

**Fig 2. On-State Voltage**

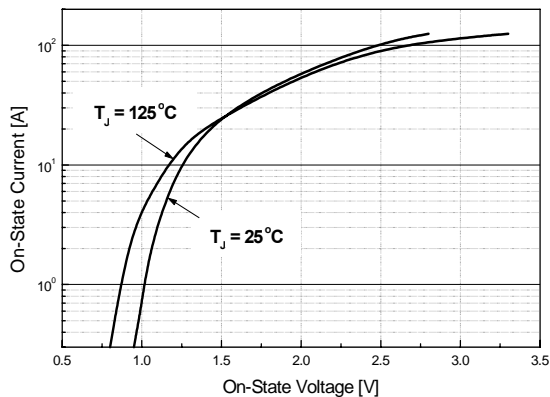

**Fig 3. On State Current vs. Maximum Power Dissipation**

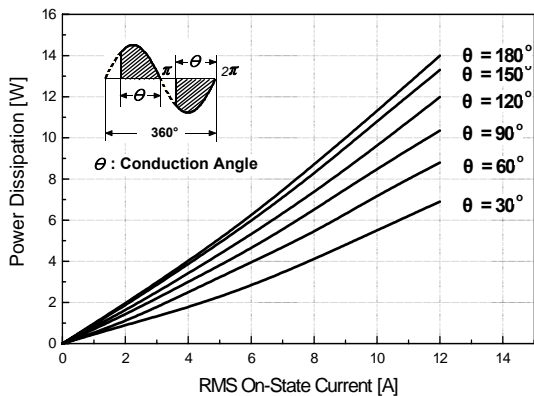

**Fig 4. On State Current vs. Allowable Case Temperature**

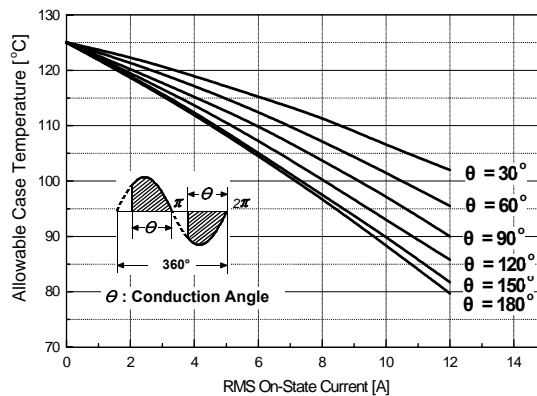

**Fig 5. Surge On-State Current Rating ( Non-Repetitive )**

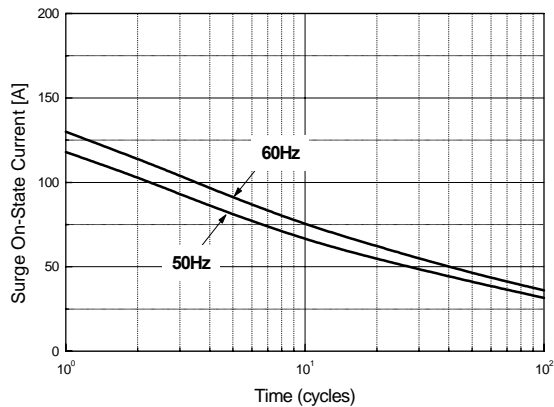

**Fig 6. Gate Trigger Voltage vs. Junction Temperature**

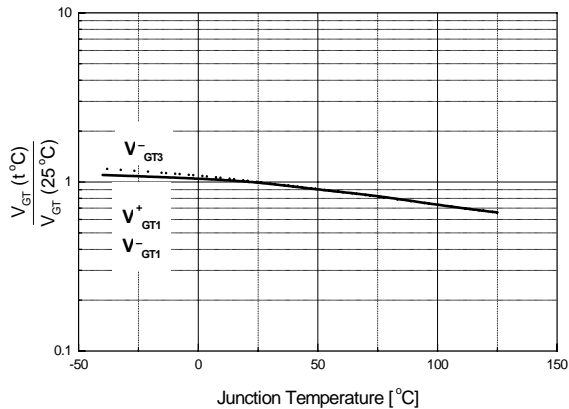

**Fig 7. Gate Trigger Current vs. Junction Temperature**

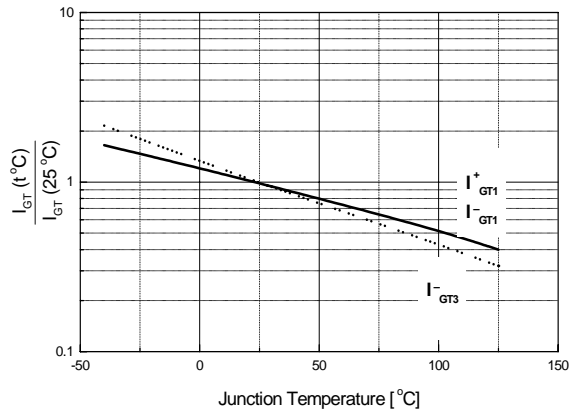

**Fig 8. Transient Thermal Impedance**

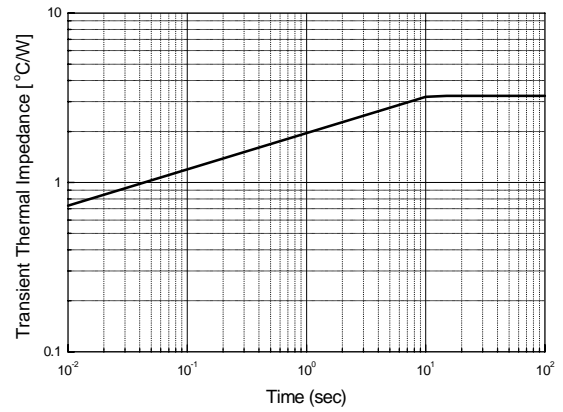

**Fig 9. Gate Trigger Characteristics Test Circuit**

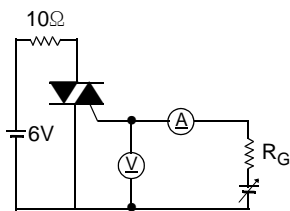

Test Procedure I

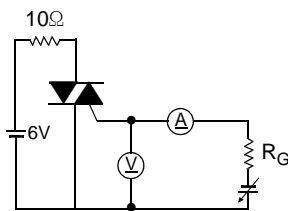

Test Procedure II

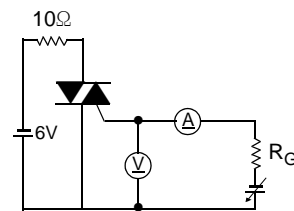

Test Procedure III

## TO-220F Package Dimension

Dim.	mm			Inch		
	Min.	Typ.	Max.	Min.	Typ.	Max.
A	10.4		10.6	0.409		0.417
B	6.18		6.44	0.243		0.254
C	9.55		9.81	0.376		0.386
D	13.47		13.73	0.530		0.540
E	6.05		6.15	0.238		0.242
F	1.26		1.36	0.050		0.054
G	3.17		3.43	0.125		0.135
H	1.87		2.13	0.074		0.084
I	2.57		2.83	0.101		0.111
J		2.54			0.100	
K		5.08			0.200	
L	2.51		2.62	0.099		0.103
M	1.25		1.55	0.049		0.061
N	0.45		0.63	0.018		0.025
O	0.6		1.0	0.024		0.039
$\phi$		3.7			0.146	
$\phi 1$		3.2			0.126	
$\phi 2$		1.5			0.059	

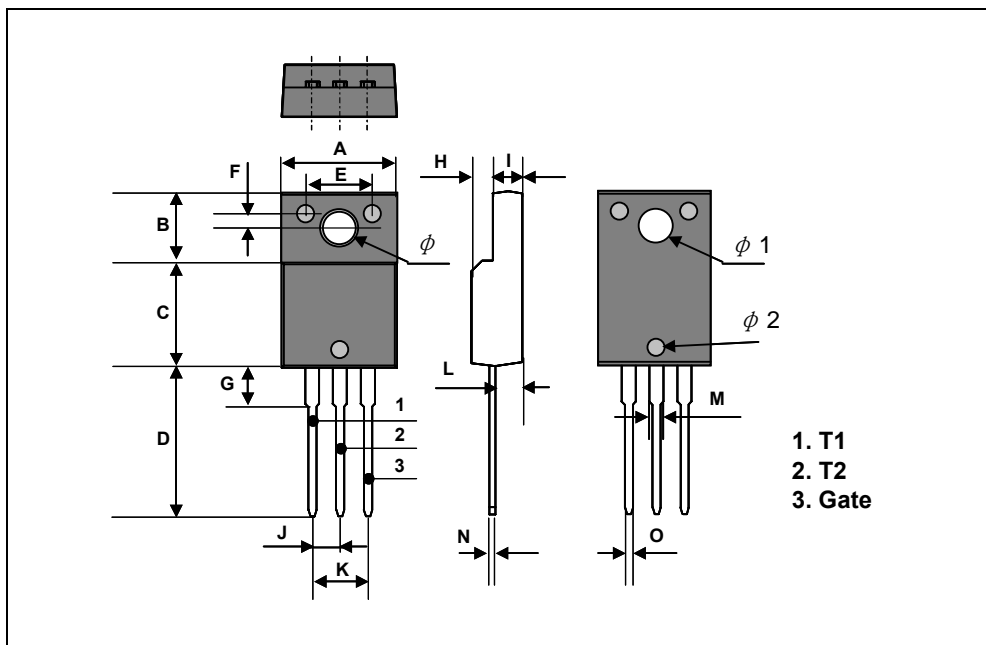

## TO-220F Package Dimension, Forming

Dim.	mm			Inch		
	Min.	Typ.	Max.	Min.	Typ.	Max.
A	10.4		10.6	0.409		0.417
B	6.18		6.44	0.243		0.254
C	9.55		9.81	0.376		0.386
D	8.4		8.66	0.331		0.341
E	6.05		6.15	0.238		0.242
F	1.26		1.36	0.050		0.054
G	3.17		3.43	0.125		0.135
H	1.87		2.13	0.074		0.084
I	2.57		2.83	0.101		0.111
J		2.54			0.100	
K		5.08			0.200	
L	2.51		2.62	0.099		0.103
M	1.25		1.55	0.049		0.061
N	0.45		0.63	0.018		0.025
O	0.6		1.0	0.024		0.039
P		5.0			0.197	
$\phi$		3.7			0.146	
$\phi 1$		3.2			0.126	
$\phi 2$		1.5			0.059	

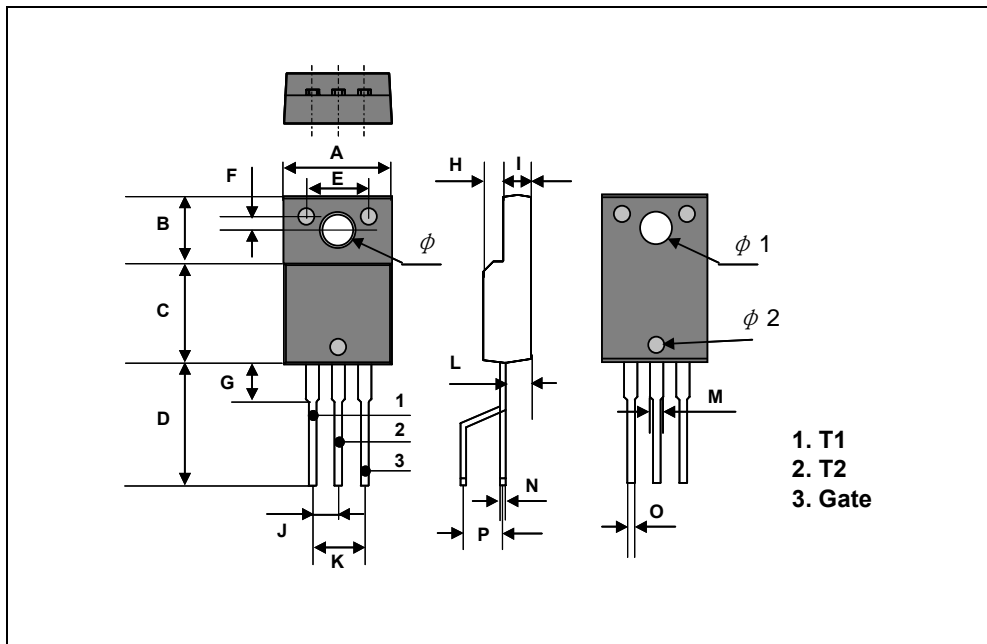

## Looking for pricing, stock, or lifecycle information?

Click below to explore more details on WIN SOURCE:

- [View BTA12-600B on WIN SOURCE](#)
- [ShenZhen SikorMicro Semicon Co. Ltd Information](#)

## Optimize Your Supply Chain with WIN SOURCE Solutions

- ✓ Global Sourcing Solution
- ✓ Obsolete Management
- ✓ Cost Control Management
- ✓ Shortage Management
- ✓ Alternative Solution
- ✓ Excess Inventory Management