



## 24V 4A sourcing current and sinking current Dual

### 1. Characteristics

- Dual-channel independent-grid driving
- 4A peak sourcing current and sinking current
- VDD power supply with wide ranges as high as 25V
- Independent enabling input
- Dual channels can be used in parallel for high current drive
- Inverting and non-inverting inputs optional
- VDD under-voltage protection
- Compatible with TTL and CMOS input levels
- low propagation delay
- Ins typical delay matching between two channels
- When the input is floating, the output is low
- -40oC to 125oC operating temperature range

### 2. Applications

- AC/DC and DC/DC converter
- Server and rectifier for communication equipment
- EV/HEV inverter and DC/DC converter
- PV voltage rise and inverter
- UPS
- motor control
- For Emerging Wide Bandgap Power Device Drivers

### 3. Description

The SL27523/4/5 are dual 4A high-speed low-side gate driver, MOSFETs and IGBTs can be driven efficiently and safely. low propagation delay late and mismatch, as well as the compact SOP-8 package, make the switching frequency of MOSFETs can reach hundreds of kHz. this chip Ideal for synchronous rectification drives for server and communication power supplies, In this case, the dead time of the synchronous MOSFET directly affects the transformer. Converter efficiency. The driver can increase the output through the parallel connection of two channels. Out the drive current. Input pin threshold voltages are based on TTL levels and -5V to 20V input.

Wide range of VDD supply voltages from 4.5V to 20V to efficiently drive MOSFET or GaN power devices. Integrated UVLO protection. It is guaranteed to keep the output low under abnormal conditions.

The -5V to 24V independent input pin voltage range effectively ensures that Stable operation with overshoot due to parasitic inductance. Input the voltage threshold of the pin is also compatible with TTL level input.

#### Distribution of pins

Dual-channel reverse input

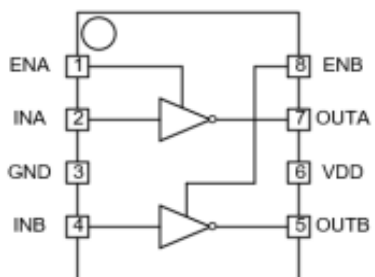

dual-channel non-reverse input

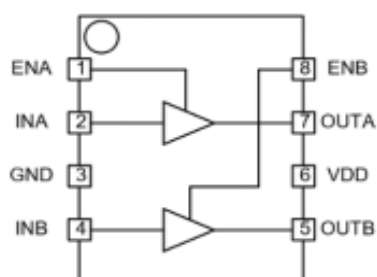

One-channel reverse input and

one-channel non-reverse input

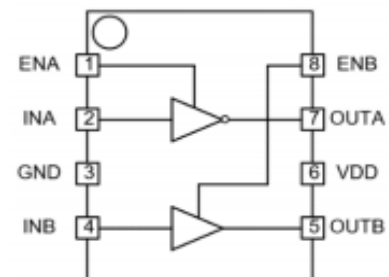

## Contents

1	Characteristics .....	1
2	Applications .....	1
3	Description .....	1
4	Configuration and functions of pins.....	2
5	Technical indexes.....	3
6	Typical Characteristics.....	5
7	Detailed description.....	6
8	Application and realization .....	7
9	PCB arrangement .....	8
10	Package information .....	9

### 4. Configuration and functions of pins

pin	Name	I/O	Description
1	ENA	I	A Channel enabling input
2	INA	I	A Channel input
3	GND	G	Ground
4	INB	I	B Channel input
5	OUTB	O	B Channel output
6	VDD	P	Supply voltage
7	OUTA	O	A Channel output
8	ENB	I	B Channel enabling input

### Truth-value table

The voltage of VDD is higher than the threshold voltage of UVLO. OUT<sub>x</sub> (x = A or B) is independently controlled by IN<sub>x</sub> and EN<sub>x</sub>

SL27523/4/5				SL27523		SL27524		SL27525	
ENA	ENB	INA	INB	OUTA	OUTB	OUTA	OUTB	OUTA	OUTB
High or suspended	High or suspended	Low	Low	Height	Height	Low	Low	Height	Low
High or suspended	High or suspended	Low	Height	Height	Low	Low	Height	Height	Height
High or suspended	High or suspended	Height	Low	Low	Height	Height	Low	Low	Low
High or suspended	High or suspended	Height	Height	Low	Low	Height	Height	Low	Height
Low	Low	Any level	Any level	Low	Low	Low	Low	Low	Low
Any level	Any level	suspended	suspended	Low	Low	Low	Low	Low	Low

## 5. Technical indexes

### 5.1 Absolute Max. rated value

Within the ranges of indoor temperature (unless otherwise specified) <sup>(1)</sup>

		MIN	MAX	Unit
V <sub>DD</sub>	Supply voltage (relative to ground)	-0.3	24	V
OUTA, OUTB	Gate drive output voltage	-0.3	V <sub>DD</sub> +0.3	V
INA, INB	signal input voltage	-5	24	V
T <sub>J</sub>	Junction temperature	-40	150	°C
T <sub>STG</sub>	storage temperature	-65	150	°C

(1) If the operation exceeds the ranges listed in the “absolute maximum rated value”, it may lead to permanent damages to the device. Long-term exposure to the absolute maximum rated value conditions may lead to influences on reliability of the device.

### 5.2 Anti-static level

		Value	Unit
V <sub>(ESD)</sub>	Human body model(HBM), ANSI/ESDA/JEDEC JS-001 <sup>(1)</sup>	+/-2000	V
	Charged device model (CDM), JEDEC specification JESD22-C101 <sup>(2)</sup>	+/-500	

(1) As specified in JEDEC document JEP155, the standard ESD control process is allowed for safe manufacturing for 500V HBM. As specified in JEDEC document JEP155, the standard ESD control process is allowed for safe manufacturing for 250V CDM.

### 5.3 Recommended working conditions

		MIN	MAX	Unit
V <sub>DD</sub>	Supply voltage	4.5	20	V
V <sub>INx, ENx</sub>	Signal input voltage	0	20	V
T <sub>A</sub>	environment temperature	-40	125	°C

### 5.4 Thermal resistance information

		Value	Unit
R <sub>θJA</sub>	junction temperature – environment	128	°C/W
R <sub>θJA</sub>	junction temperature –PCB	68.5	°C/W

## 5.5 Electrical specifications

VDD = 12 V, TA = -40°C to 125°C, Unless otherwise specified.

In the environment of 25°C, in the designated pin, the positive-going current is input, and the inversed current is output.

Parameters	Testing conditions	MIN	Type	MAX	Unit
<b>Bias current</b>					
I <sub>DDoff</sub> Starting current	VDD=3V, OUTA=OUTB=0V		70		μA
I <sub>DDq</sub> Quiescent current	INA=INB=0V		180		μA
<b>Under voltage protection (SL27524)</b>					
V <sub>ON</sub> under voltage threshold value V <sub>OFF</sub>	Rise threshold value		3.8	4.2	V
	Drop threshold value	3.2	3.5		
<b>Under voltage protection (SL27523/5)</b>					
V <sub>ON</sub> under voltage locking threshold value V <sub>OFF</sub>	Rise threshold value		3.8	4.25	V
	Drop threshold value	3.2	3.5		
<b>Inverting input (INA for SL27523, INB and INA for SL27525)</b>					
V <sub>INH</sub> input rise threshold value			1.8	2.4	V
V <sub>INL</sub> input drop threshold value		0.8	1.1		V
V <sub>INHYS</sub> input hysteresis			0.8		V
V <sub>INHYS</sub> Negative voltage input		-5			V
<b>Non-inverting input (INA, INB for SL27524 and INB for SL27525)</b>					
V <sub>INH</sub> input rise threshold value			2.0	2.4	V
V <sub>INL</sub> input drop threshold value		0.8	1.2		V
V <sub>INHYS</sub> input hysteresis			0.8		V
V <sub>INHYS</sub> Negative voltage input		-5			V
<b>enable input(ENA, ENB)</b>					
V <sub>ENH</sub> Enable Input Rising Threshold			1.8	2.2	V
V <sub>ENL</sub> Enable Input Falling Threshold		0.8	1.1		V
V <sub>INHYS</sub> Enable input hysteresis			0.7		V
<b>OUTPUT (OUTA, OUTB)</b>					
I <sub>o</sub> Sourcing and sinking current peak	C <sub>LOAD</sub> =0.22μF, With external current limiting resistor, 1kHz switching frequency		4		A
V <sub>OH</sub> output high level	I <sub>OUTH</sub> = -10mA	V <sub>DD</sub> -0.05	V <sub>DD</sub> -0.12		V
V <sub>OL</sub> output low voltage	I <sub>OUTL</sub> = 10mA	0.0057	0.012		V
R <sub>OH</sub> output quiescent pull-up resistance			5 12		Ω
R <sub>OL</sub> output pull-down resistance			0.57	1.2	Ω
<b>Time series</b>					
T <sub>Dff</sub> drop dela	Cload = 1.8nF		16		ns
T <sub>Dff</sub> rise dela			16		
T <sub>f</sub> drop time	Cload = 1.8nF		6		ns
T <sub>f</sub> rise time			6		
T <sub>dm</sub> delay mismatch	INA=INB, ENA=ENB=VDD (SL27523 and SL27524 )		1		ns

## 6. Typical Characteristics

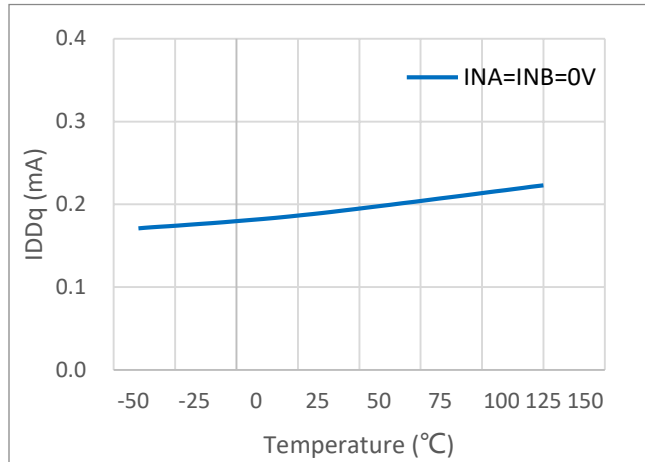

Figure 1. Quiescent current  $IDDq$  vs temperature

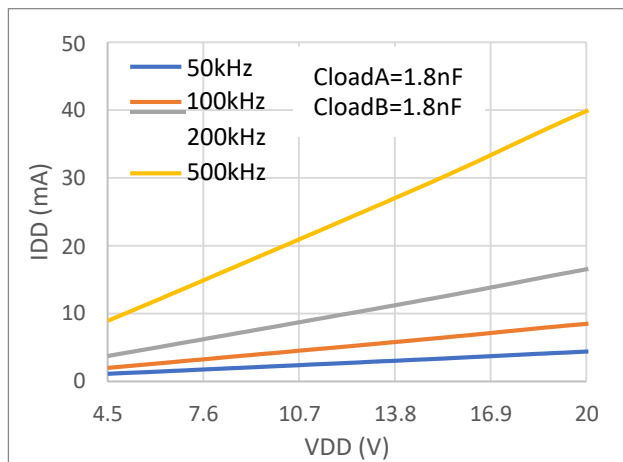

Figure 2. Working current  $IDDq$  vs VDD

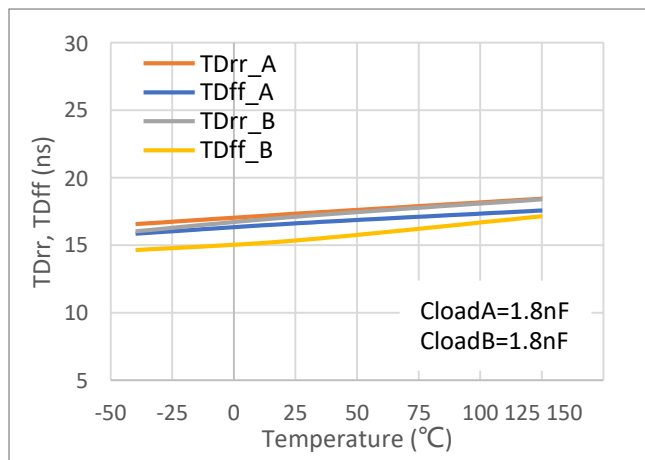

Figure 3. Propagation delay vs temperature

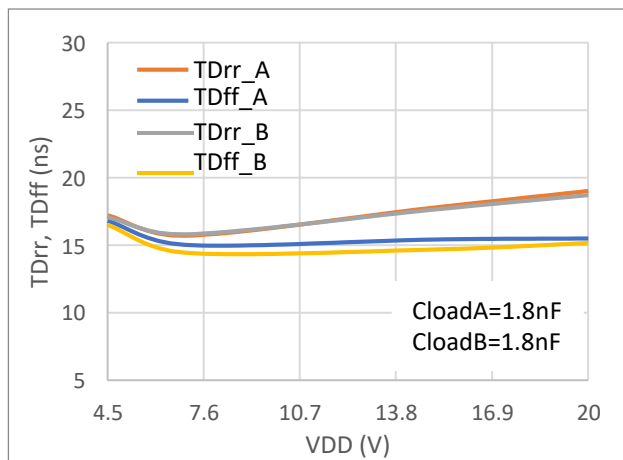

Figure 4. Propagation delay vs VDD

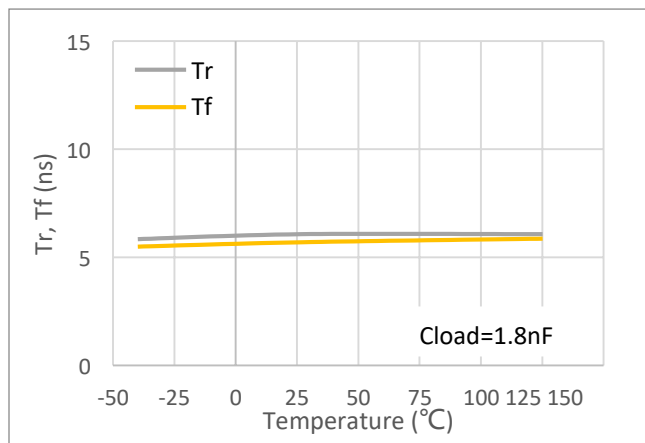

Figure 5. Rise time and drop time vs temperature

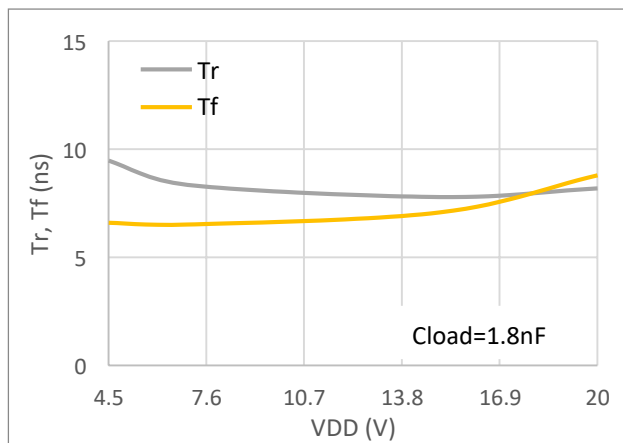

Figure 6. Rise time and drop time vs VDD

## 7. Detailed description

The SL27523/4/5 drivers provide dual-channel high-speed low-side gate drive. The SL27523/4 can reduce output signal mismatch when paralleling two channels to drive high power or parallel power switches.

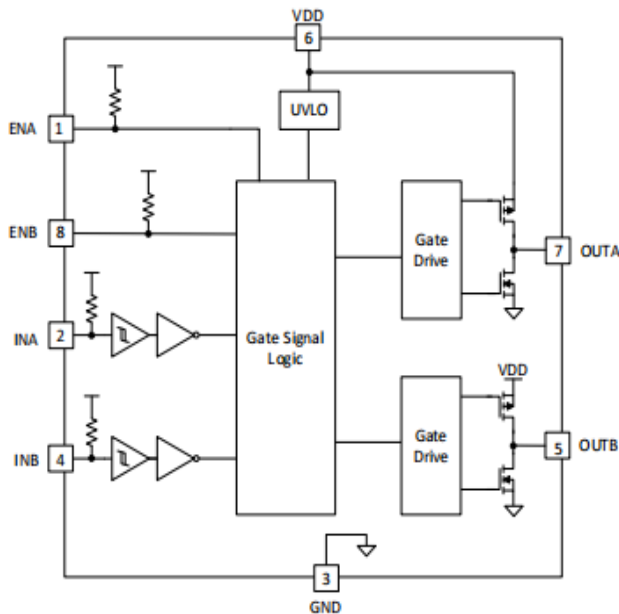

Figure 7. Functional block diagram of SL27523

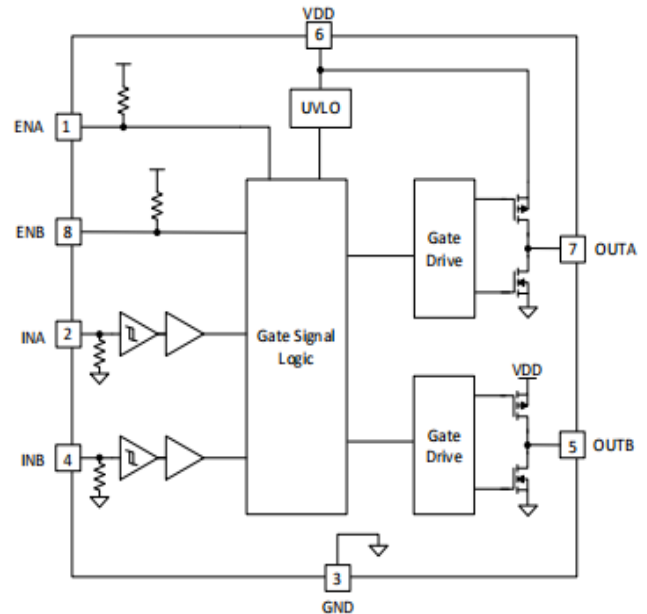

Figure 8. Functional block diagram of SL27524

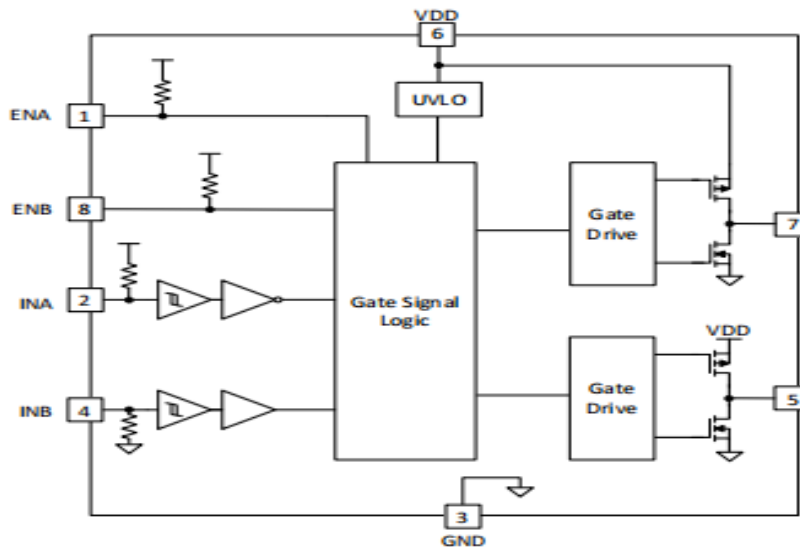

Figure 9 Functional block diagram of SL27525

### 7.1 Input signal INA and INB

INA and INB are grid driving input. All the reverse input pins (INA and INB of SL27523 and INA of SL27525) are pull-up input, and all the non-reverse input pins (INA and INB of SL27524 and INB of SL27525) are pull-down input. If input is kept floating, the output will be pulled to the ground. The input is the TTL and CMOS compatible logic level, with the maximum input tolerance of 24V.

## 7.2 Enabling signals ENA and ENB

ENA and ENB are enable control signals. The enable control signal is compatible with TTL and CMOS logic levels with a maximum input tolerance of 24V. When ENx is pulled low, the OUTx output is low. When ENx is pulled high or left floating, OUTx follows the input of Inx (INA, INB and INB of ) or OUTx is INx (INA, INB and INA of )

## 7.3 The reverse of the input. The enable pin is a weak pull-up. OUTA and OUTB

OUTA and OUTB are push-pull outputs, composed by a pair of complexed pull-up P model and N model MOSFET and a pull-down MOSFET. Each output of SL27523/4/5 can provide 4A sourcing current pulse and sinking current pulse. The output voltage swing in a rail-to-rail way from VDD and GND. The diode of MOSFET will also provide voltage clamping access to restrain the output voltage to exceed or lower than the ranges. In many conditions, the external Schottky diode clamping is not necessary.

## 7.4 VDD and undervoltage protection

The maximum rated input voltage of SL27523/4/5 is 24V, which can meet the requirements on grid driving of Si MOSFET, IGBT and SiC MOSFET. SL27511 can meet the grid driving requirements of Si MOSFET, IGBT, and SiC MOSFET. SL27511 can meet the grid driving requirements of Si MOSFET、IGBT, and SiC MOSFET.

## 8. Application and realization

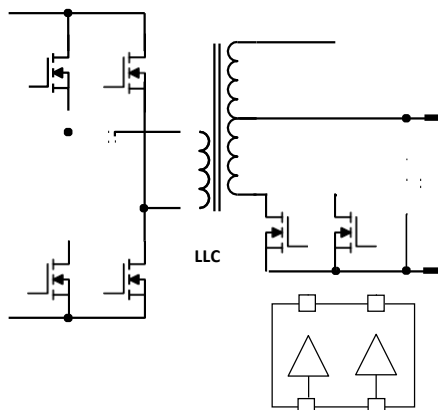

Figure 10. Driving by two channels separately ( SL27523/4/5)

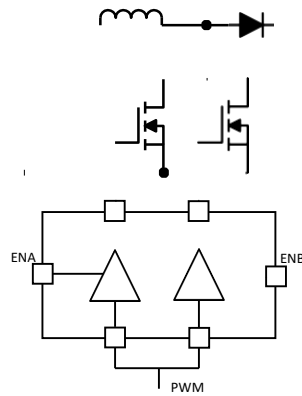

Figure 11. Two outputs drive two parallel switching devices with the minimum mismatching (SL27523/4/5)

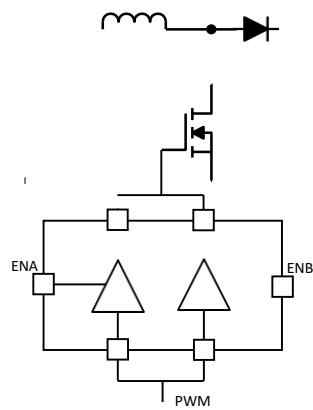

Figure 12. Two outputs drive one large power switching device in a parallel way with the minimum mismatching (SL27523/4)

**9. PCB arrangement**

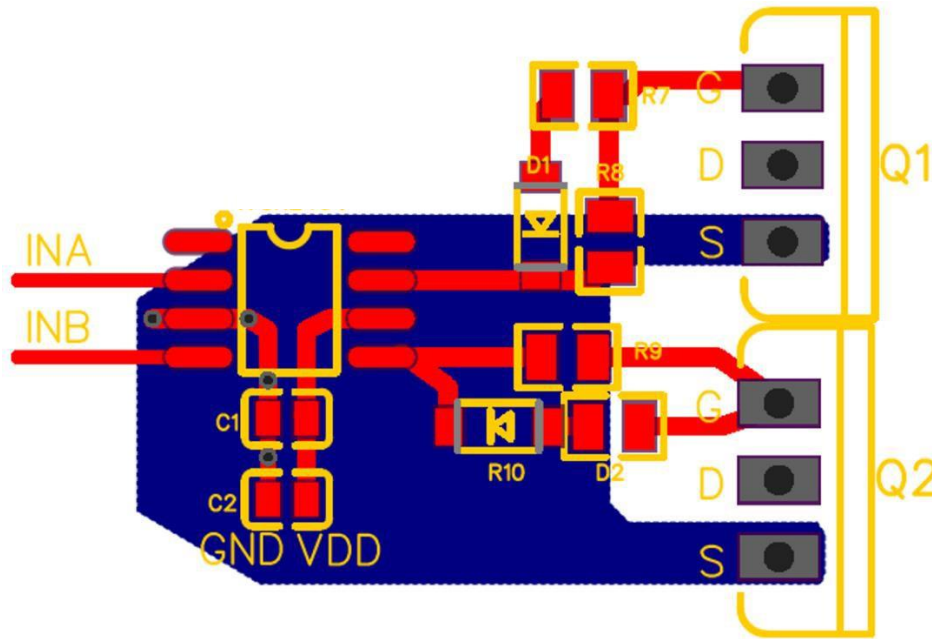
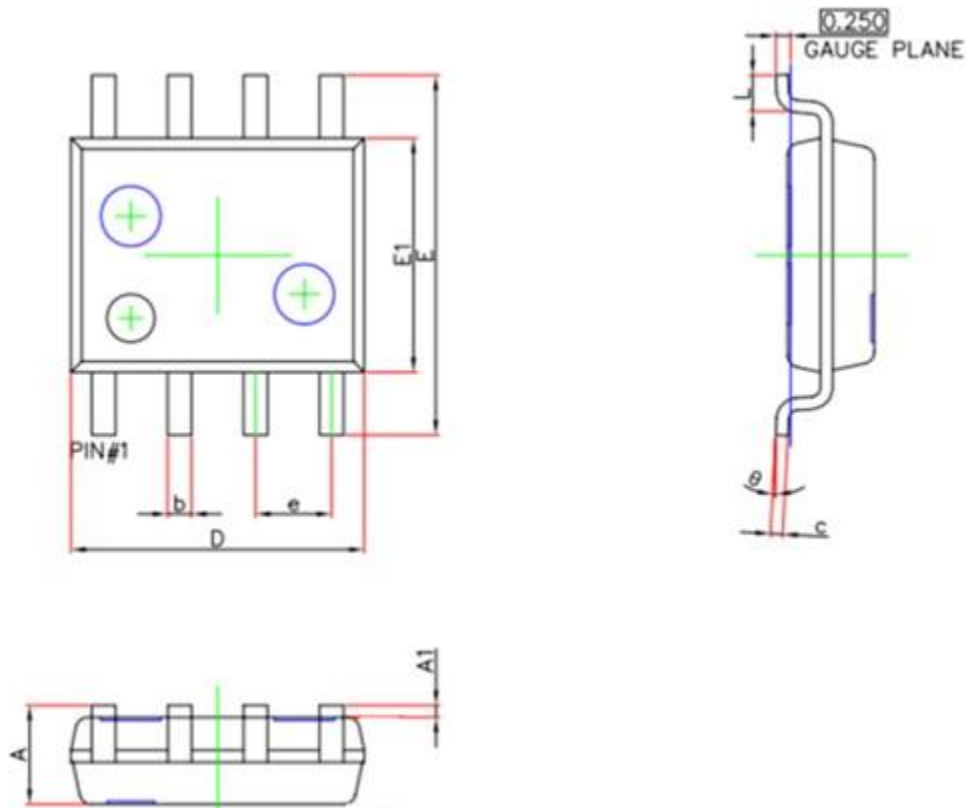

Figure 13. Case for arrangement of SL27523/4/5

**10. Package information**



## SOP-8 package dimension



symbol	Dimension (mm)		Dimension (inch)	
	MIN	MAX	MIN	MAX
A	1.350	1.750	0.053	0.069
A1	0.110	0.250	0.004	0.010
b	0.310	0.510	0.012	0.020
c	0.130	0.250	0.005	0.010
D	4.810	5.000	0.189	0.197
E	5.800	6.190	0.228	0.244
E1	3.810	3.980	0.150	0.157
e	1.270		0.050	
L	0.410	1.270	0.016	0.050
θ	0.000	8.000	0.000	0.315

## Looking for pricing, stock, or lifecycle information?

Click below to explore more details on WIN SOURCE:

-  [View SL27525 on WIN SOURCE](#)
-  [ShenZhen SikorMicro Semicon Co. Ltd Information](#)

## Optimize Your Supply Chain with WIN SOURCE Solutions

-  Global Sourcing Solution
-  Obsolete Management
-  Cost Control Management
-  Shortage Management
-  Alternative Solution
-  Excess Inventory Management