



# THE DATASHEET OF SS18



## Surface Mount Schottky Rectifiers

### Features

- Low profile package
- Ideal for automated placement
- Ultrafast reverse recovery time
- Low power losses, high efficiency
- Low forward voltage drop
- High surge capability
- High temperature soldering:  
260°C/10 seconds at terminals

### Mechanical Date

- **Case:** JEDEC DO-214AC molded plastic body over glass passivated chip
- **Terminals:** Solder plated, solderable per J-STD-002B and JESD22-B102D

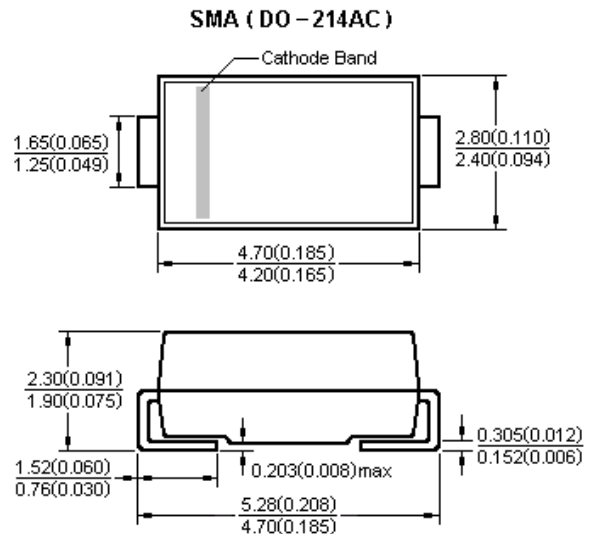

Dimensions in millimeters and (inches)

### Major Ratings and Characteristics

$I_{F(AV)}$	1.0A
$V_{RRM}$	20 V to 100 V
$I_{FSM}$	40A
$V_F$	0.50V, 0.55V, 0.70V, 0.85V
$T_j \text{ max.}$	125 °C

### Maximum Ratings & Thermal Characteristics

( $T_A = 25\text{ °C}$  unless otherwise noted)

Items	Symbol	SS12	SS13	SS14	SS15	SS16	SS18	SS110	UNIT
Maximum repetitive peak reverse voltage	$V_{RRM}$	20	30	40	50	60	80	100	V
Maximum RMS voltage	$V_{RMS}$	14	21	28	35	42	56	70	V
Maximum DC blocking voltage	$V_{DC}$	20	30	40	50	60	80	100	V
Maximum average forward rectified current	$I_{F(AV)}$	1.0							A
Peak forward surge current 8.3 ms single half sine-wave superimposed on rated load	$I_{FSM}$	40							A
Voltage rate of change (rated $V_R$ )	$dv/dt$	10000							V/ $\mu$ s
Thermal resistance from junction to lead <sup>(1)</sup>	$R_{\theta JL}$	35							°C/W
Operating junction and storage temperature range	$T_J, T_{STG}$	-65 to +125							°C

Note 1: Mounted on P.C.B. with 0.2 x 0.2" (5.0 x 5.0mm) copper pad areas.

### Electrical Characteristics ( $T_A = 25\text{ °C}$ unless otherwise noted)

Items	Test conditions	Symbol	SS12	SS13~14	SS15~16	SS18~110	UNIT	
Instantaneous forward voltage	$I_F = 1.0A^{(2)}$	$V_F$	0.50	0.55	0.70	0.85	V	
Reverse current	$V_R = V_{DC}$	$I_R$	$T_A = 25\text{ °C}$				0.5	mA
			$T_A = 100\text{ °C}$				5	

Note 2: Pulse test: 300 $\mu$ s pulse width, 1% duty cycle.

## Characteristic Curves ( $T_A=25\text{ }^\circ\text{C}$ unless otherwise noted)

**Fig.1 Forward Current Derating Curve**

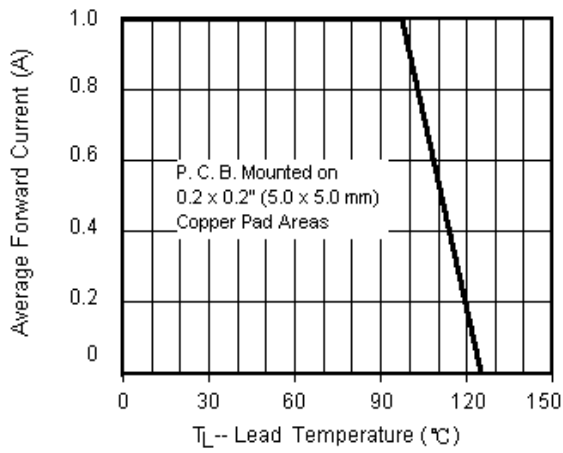

**Fig.2 Maximum Non-Repetitive Peak Forward Surge Current**

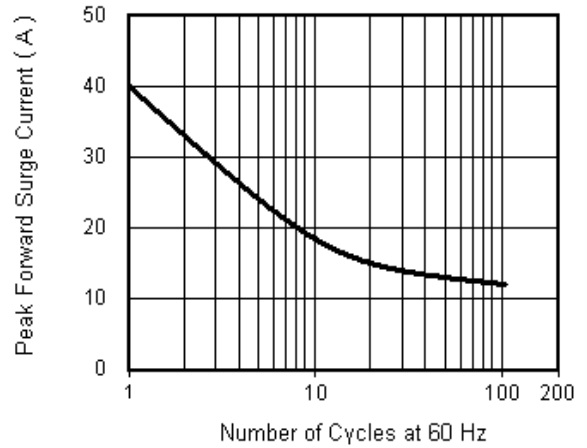

**Fig.3 Typical Instantaneous Forward Characteristics**

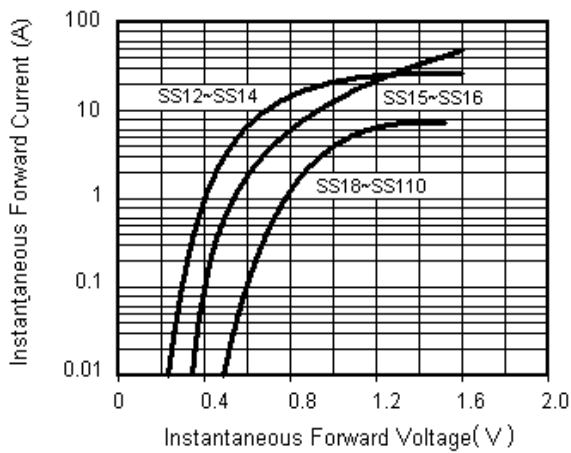

**Fig.4 Typical Reverse Leakage Characteristics**

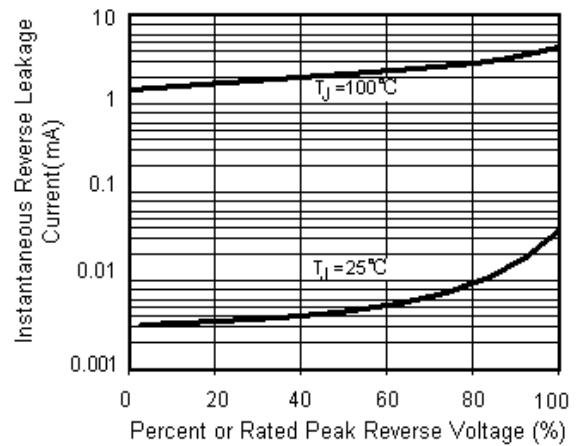

## Looking for pricing, stock, or lifecycle information?

Click below to explore more details on WIN SOURCE:

- [View SS18 on WIN SOURCE](#)
- [ShenZhen SikorMicro Semicon Co. Ltd Information](#)

## Optimize Your Supply Chain with WIN SOURCE Solutions

- ✓ Global Sourcing Solution
- ✓ Obsolete Management
- ✓ Cost Control Management
- ✓ Shortage Management
- ✓ Alternative Solution
- ✓ Excess Inventory Management