

RF LDMOS Integrated Power Amplifiers

Wideband integrated circuit is suitable for industrial heating applications operating at 2450 MHz. This multi-stage structure is rated for 26 to 32 V operation in both CW and pulse applications.

- Typical CW Performance: $V_{DD} = 28$ Vdc, $I_{DQ1} = 55$ mA, $I_{DQ2} = 195$ mA, $P_{out} = 25$ W CW, $f = 2450$ MHz
 Power Gain — 27.7 dB
 Power Added Efficiency — 43.8%
- Capable of Handling 10:1 VSWR, @ 28 Vdc, 2450 MHz, 25 W CW Output Power

Features

- Multi-stage structure is rated for 26 to 32 V Operation
- Integrated Quiescent Current Temperature Compensation with Enable/Disable Function (1)
- Integrated ESD Protection
- Excellent Thermal Stability
- 225°C Capable Plastic Package
- In Tape and Reel. R1 Suffix = 500 Units, 44 mm Tape Width, 13-inch Reel.

MHT2000NR1
MHT2000GNR1

2450 MHz, 25 W CW, 28 V
INDUSTRIAL HEATING, RUGGED
RF LDMOS INTEGRATED
POWER AMPLIFIERS

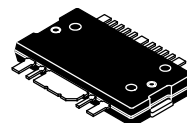

TO-270WB-16
PLASTIC
MHT2000NR1

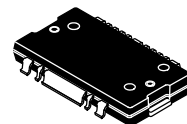

TO-270WBG-16
PLASTIC
MHT2000GNR1

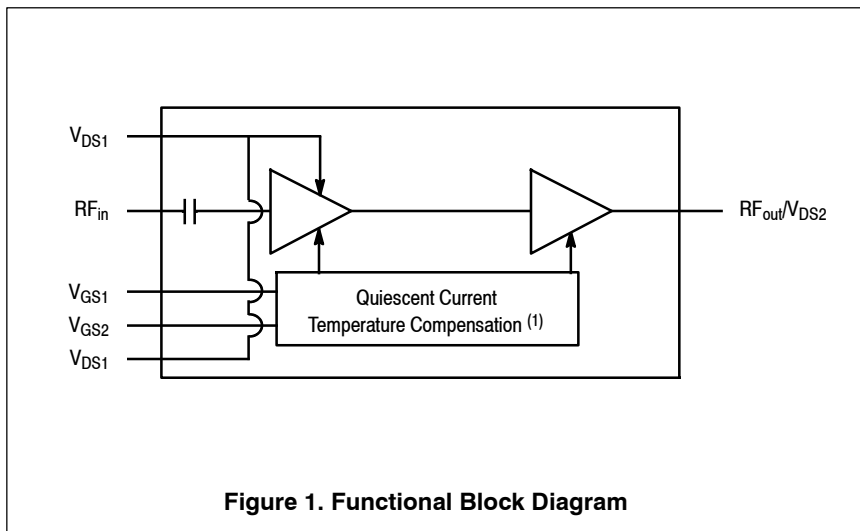

Figure 1. Functional Block Diagram

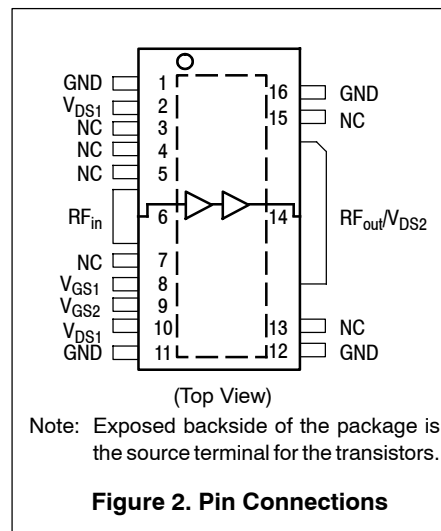

Figure 2. Pin Connections

1. Refer to AN1977, *Quiescent Current Thermal Tracking Circuit in the RF Integrated Circuit Family*, and to AN1987, *Quiescent Current Control for the RF Integrated Circuit Device Family*. Go to <http://www.freescale.com/rf>. Select Documentation/Application Notes - AN1977 or AN1987.

Table 1. Maximum Ratings

Rating	Symbol	Value	Unit
Drain-Source Voltage	V_{DS}	-0.5, +65	Vdc
Gate-Source Voltage	V_{GS}	-0.5, +10	Vdc
Operating Voltage	V_{DD}	32, +0	Vdc
Storage Temperature Range	T_{stg}	-65 to +150	°C
Case Operating Temperature	T_C	150	°C
Operating Junction Temperature (1,2)	T_J	225	°C
Input Power	P_{in}	20	dBm

Table 2. Thermal Characteristics (In Freescale Narrowband Test Fixture)

Characteristic	Symbol	Value (2,3)	Unit
Thermal Resistance, Junction to Case (Case Temperature 80°C, $P_{out} = 25$ W CW)	$R_{\theta JC}$	6.1 1.2	°C/W
		Stage 1, 28 Vdc, $I_{DQ1} = 55$ mA	
		Stage 2, 28 Vdc, $I_{DQ2} = 195$ mA	

Table 3. ESD Protection Characteristics

Test Methodology	Class
Human Body Model (per JESD22-A114)	1B
Machine Model (per EIA/JESD22-A115)	A
Charge Device Model (per JESD22-C101)	II

Table 4. Moisture Sensitivity Level

Test Methodology	Rating	Package Peak Temperature	Unit
Per JESD22-A113, IPC/JEDEC J-STD-020	3	260	°C

Table 5. Electrical Characteristics ($T_C = 25^\circ\text{C}$ unless otherwise noted)

Characteristic	Symbol	Min	Typ	Max	Unit
----------------	--------	-----	-----	-----	------

Stage 1 - Off Characteristics

Zero Gate Voltage Drain Leakage Current ($V_{DS} = 65$ Vdc, $V_{GS} = 0$ Vdc)	I_{DSS}	—	—	10	μAdc
Zero Gate Voltage Drain Leakage Current ($V_{DS} = 28$ Vdc, $V_{GS} = 0$ Vdc)	I_{DSS}	—	—	1	μAdc
Gate-Source Leakage Current ($V_{GS} = 1.5$ Vdc, $V_{DS} = 0$ Vdc)	I_{GSS}	—	—	1	μAdc

Stage 1 - On Characteristics

Gate Threshold Voltage ($V_{DS} = 10$ Vdc, $I_D = 20$ μAdc)	$V_{GS(th)}$	1.2	1.9	2.7	Vdc
Gate Quiescent Voltage ($V_{DS} = 28$ Vdc, $I_{DQ1} = 55$ mA) (4)	$V_{GS(Q)}$	—	2.7	—	Vdc
Fixture Gate Quiescent Voltage ($V_{DD} = 28$ Vdc, $I_{DQ1} = 55$ mA) (4,5)	$V_{GG(Q)}$	10.3	11.2	12.6	Vdc

1. Continuous use at maximum temperature will affect MTTF.
2. MTTF calculator available at <http://www.freescale.com/rf>. Select Software & Tools/Development Tools/Calculators to access MTTF calculators by product.
3. Refer to AN1955, *Thermal Measurement Methodology of RF Power Amplifiers*. Go to <http://www.freescale.com/rf>. Select Documentation/Application Notes - AN1955.
4. Measured in Freescale Narrowband Test Fixture.
5. See Appendix A for functional test measurements and test fixture.

(continued)

Table 5. Electrical Characteristics ($T_C = 25^\circ\text{C}$ unless otherwise noted) (continued)

Characteristic	Symbol	Min	Typ	Max	Unit
Stage 2 - Off Characteristics					
Zero Gate Voltage Drain Leakage Current ($V_{DS} = 65\text{ Vdc}$, $V_{GS} = 0\text{ Vdc}$)	I_{DSS}	—	—	10	$\mu\text{A dc}$
Zero Gate Voltage Drain Leakage Current ($V_{DS} = 28\text{ Vdc}$, $V_{GS} = 0\text{ Vdc}$)	I_{DSS}	—	—	1	$\mu\text{A dc}$
Gate-Source Leakage Current ($V_{GS} = 1.5\text{ Vdc}$, $V_{DS} = 0\text{ Vdc}$)	I_{GSS}	—	—	1	$\mu\text{A dc}$

Stage 2 - On Characteristics

Gate Threshold Voltage ($V_{DS} = 10\text{ Vdc}$, $I_D = 80\ \mu\text{A dc}$)	$V_{GS(th)}$	1.2	1.9	2.7	Vdc
Gate Quiescent Voltage ($V_{DS} = 28\text{ Vdc}$, $I_{DQ2} = 195\text{ mA dc}$) (1)	$V_{GS(Q)}$	—	2.7	—	Vdc
Fixture Gate Quiescent Voltage ($V_{DD} = 28\text{ Vdc}$, $I_{DQ2} = 195\text{ mA dc}$) (1,2)	$V_{GG(Q)}$	9.5	10.5	11.5	Vdc
Drain-Source On-Voltage ($V_{GS} = 10\text{ Vdc}$, $I_D = 800\text{ mA dc}$)	$V_{DS(on)}$	0.15	0.47	0.8	Vdc

Stage 2 - Dynamic Characteristics (3)

Output Capacitance ($V_{DS} = 28\text{ Vdc} \pm 30\text{ mV(rms)ac}$ @ 1 MHz, $V_{GS} = 0\text{ Vdc}$)	C_{oss}	—	111	—	pF
---	-----------	---	-----	---	----

Narrowband Performance Specifications (4) (In Freescale Narrowband Test Fixture, (1) 50 ohm system) $V_{DD} = 28\text{ Vdc}$, $I_{DQ1} = 55\text{ mA}$, $I_{DQ2} = 195\text{ mA}$, $P_{out} = 25\text{ W CW}$, $f = 2450\text{ MHz}$

Power Gain	G_{ps}	25.5	27.7	30.5	dB
Power Added Efficiency	PAE	41.5	43.8	—	%
Input Return Loss	IRL	—	-18	-10	dB

Functional Tests (2) (In Freescale Test Fixture, 50 ohm system) $V_{DD} = 28\text{ Vdc}$, $I_{DQ1} = 77\text{ mA}$, $I_{DQ2} = 275\text{ mA}$, $P_{out} = 4\text{ W Avg.}$, $f = 2700\text{ MHz}$, WiMAX, OFDM 802.16d, 64 QAM $3/4$, 4 Bursts, 10 MHz Channel Bandwidth, Input Signal PAR = 9.5 dB @ 0.01% Probability on CCDF. ACPR measured in 1 MHz Channel Bandwidth @ $\pm 8.5\text{ MHz}$ Offset.

Power Gain	G_{ps}	25.5	28.5	30.5	dB
Power Added Efficiency	PAE	15	17	—	%
Output Peak-to-Average Ratio @ 0.01% Probability on CCDF	PAR	—	9	—	dB
Adjacent Channel Power Ratio	ACPR	—	-50	-46	dBc
Input Return Loss	IRL	—	-15	-10	dB

1. Measured in Freescale Narrowband Test Fixture.
2. See Appendix A for functional test fixture documentation.
3. Part internally matched both on input and output.
4. Measurements made with device in straight lead configuration before any lead forming operation is applied. Lead forming is used for gull wing (GN) parts.

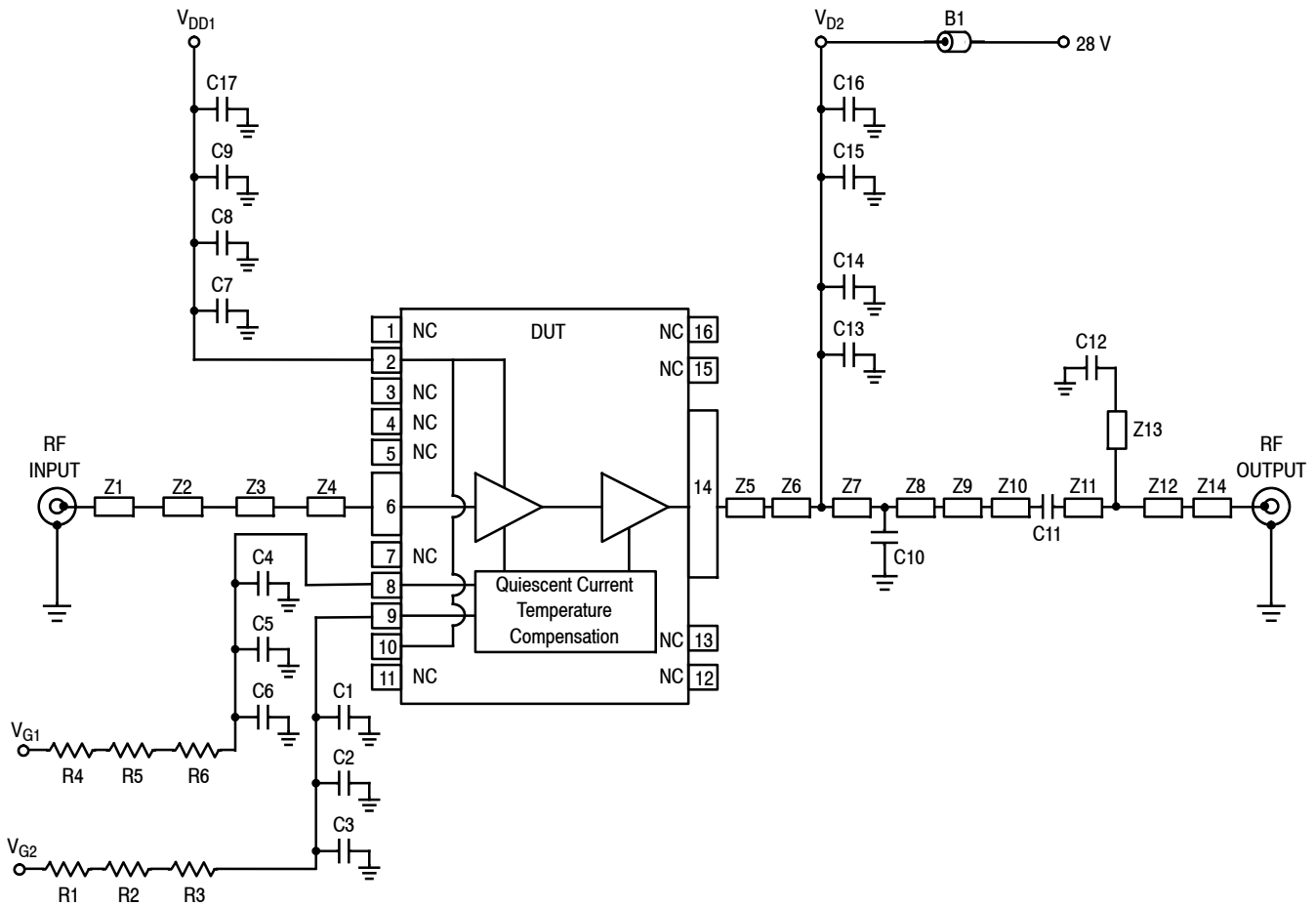

- | | | | |
|----|--------------------------------|------|--|
| Z1 | 0.500" x 0.027" Microstrip | Z9 | 0.040" x 0.061" Microstrip |
| Z2 | 0.075" x 0.127" Microstrip | Z10 | 0.020" x 0.050" Microstrip |
| Z3 | 1.640" x 0.027" Microstrip | Z11 | 0.050" x 0.050" Microstrip |
| Z4 | 0.100" x 0.042" Microstrip | Z12 | 0.050" x 0.027" Microstrip |
| Z5 | 0.151" x 0.268" Microstrip | Z13* | 0.338" x 0.020" Microstrip |
| Z6 | 0.025" x 0.268" x 0.056" Taper | Z14 | 1.551" x 0.027" Microstrip |
| Z7 | 0.100" x 0.056" Microstrip | PCB | Rogers R04350B, 0.0133", $\epsilon_r = 3.48$ |
| Z8 | 0.306" x 0.056" Microstrip | | |
- * Line length includes microstrip bends

Figure 3. MHT2000NR1 Narrowband Test Circuit Schematic

Table 6. MHT2000NR1 Narrowband Test Circuit Component Designations and Values

Part	Description	Part Number	Manufacturer
B1	47 Ω , 100 MHz Short Ferrite Bead	2743019447	Fair-Rite
C1, C4, C7, C12, C15	6.8 pF Chip Capacitors	ATC600S6R8CT250XT	ATC
C2, C5, C8, C13	10 nF Chip Capacitors	C0603C103J5RAC	Kemet
C3, C6, C9, C14	1 μ F, 50 V Chip Capacitors	GRM32RR71H105KA01B	Murata
C10	2.4 pF Chip Capacitor	ATC600S2R4BT250XT	ATC
C11	3.3 pF Chip Capacitor	ATC600S3R3BT250XT	ATC
C16, C17	10 μ F, 50 V Chip Capacitors	GRM55DR61H106KA88B	Murata
R1, R4	12 K Ω , 1/4 W Chip Resistors	CRCW12061202FKEA	Vishay
R2, R3, R5, R6	1 K Ω , 1/4 W Chip Resistors	CRCW12061001FKEA	Vishay

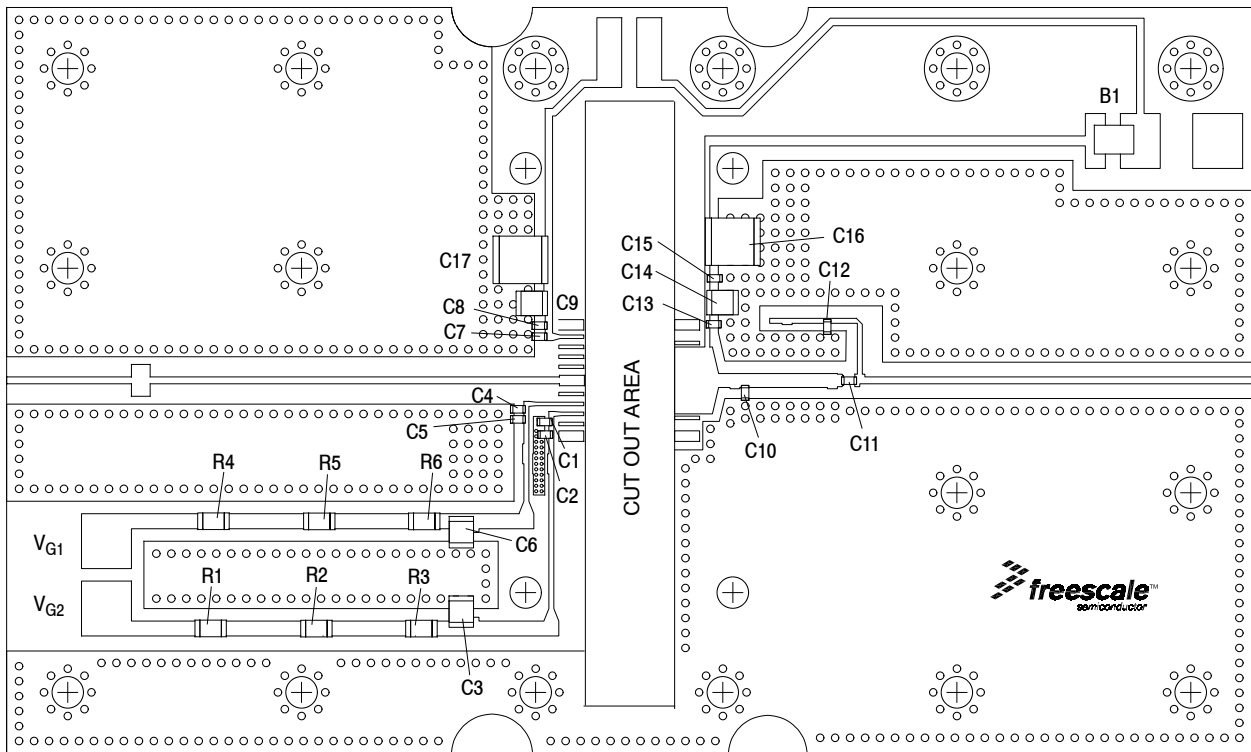

Figure 4. MHT2000NR1 Narrowband Test Circuit Component Layout

TYPICAL CHARACTERISTICS — NARROWBAND

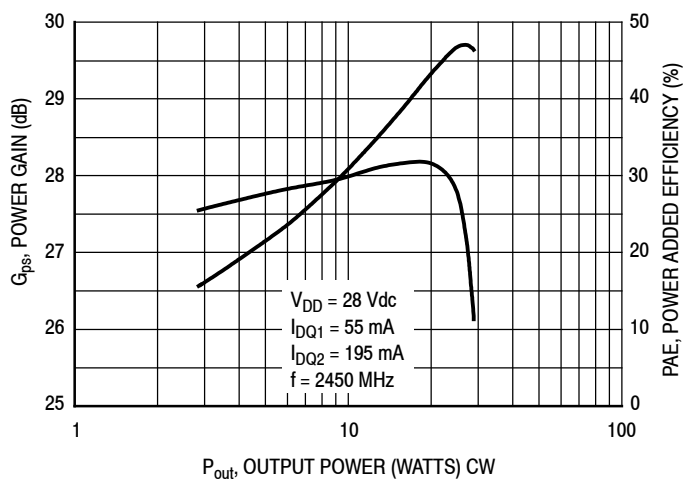

Figure 5. Power Gain and Power Added Efficiency versus CW Output Power

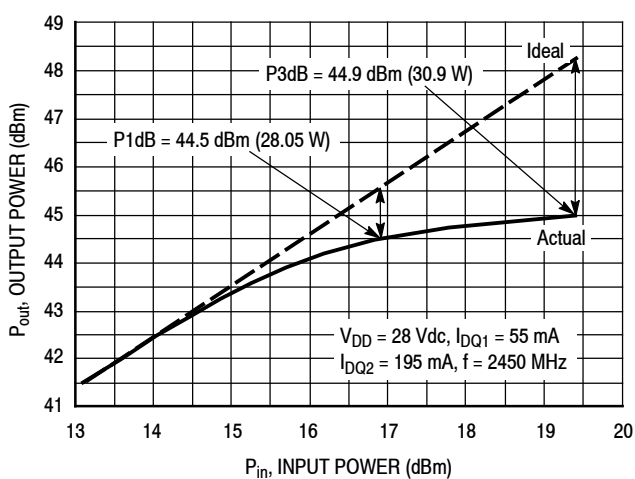

Figure 6. CW Output Power versus Input Power

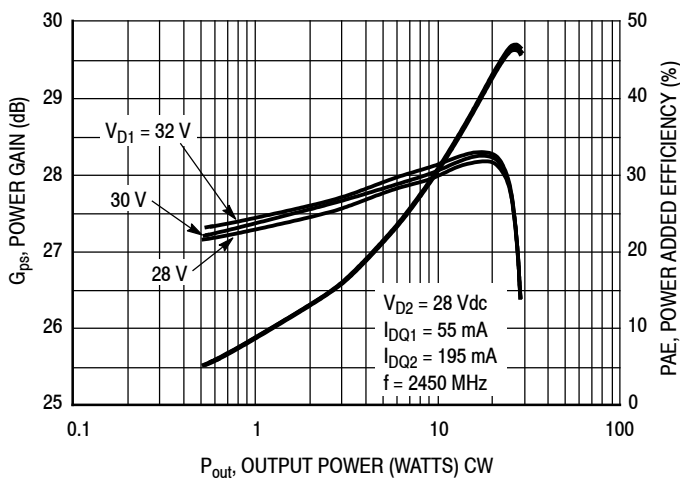

Figure 7. Power Gain and Power Added Efficiency versus CW Output Power as a Function of V_{D1}

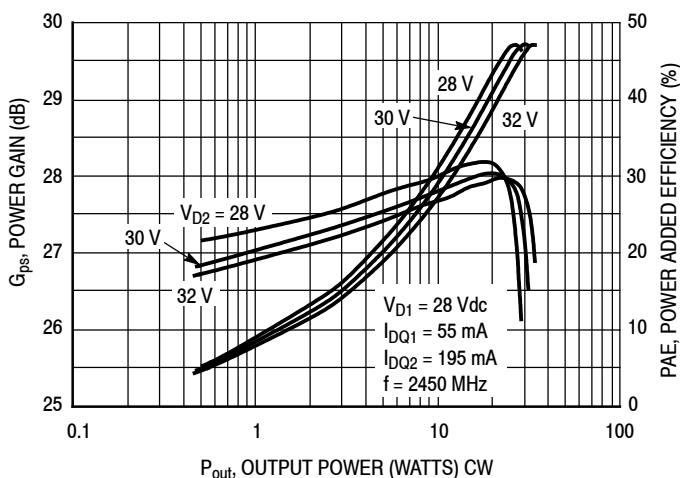

Figure 8. Power Gain and Power Added Efficiency versus CW Output Power as a Function of V_{D2}

TYPICAL CHARACTERISTICS — NARROWBAND

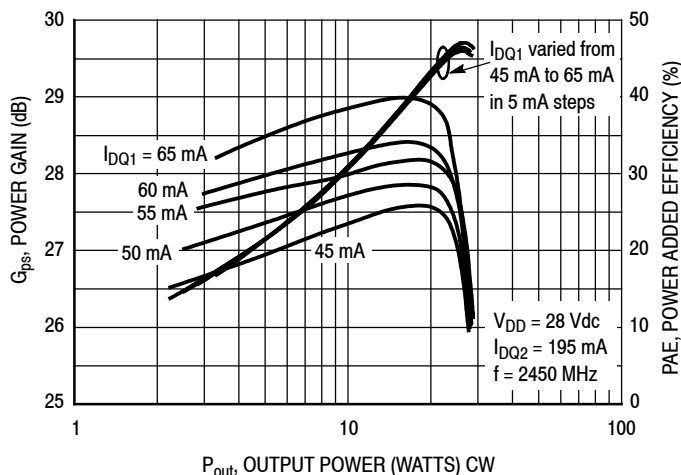

Figure 9. Power Gain and Power Added Efficiency versus CW Output Power as a Function of I_{DQ1}

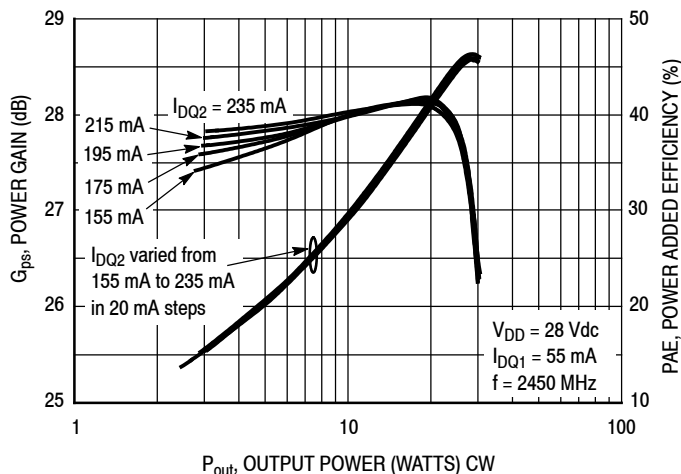
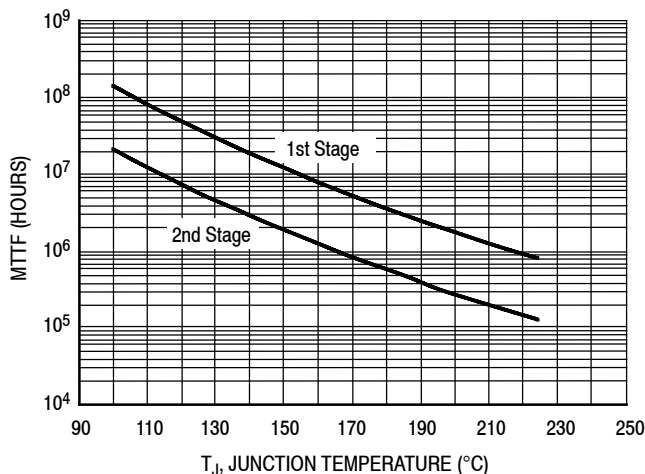

Figure 10. Power Gain and Power Added Efficiency versus CW Output Power as a Function of I_{DQ2}



This above graph displays calculated MTTF in hours when the device is operated at $V_{DD} = 28$ Vdc, $P_{out} = 25$ W CW, and PAE = 43.8%.

MTTF calculator available at <http://www.freescale.com/rf>. Select Software & Tools/Development Tools/Calculators to access MTTF calculators by product.

Figure 11. MTTF versus Junction Temperature

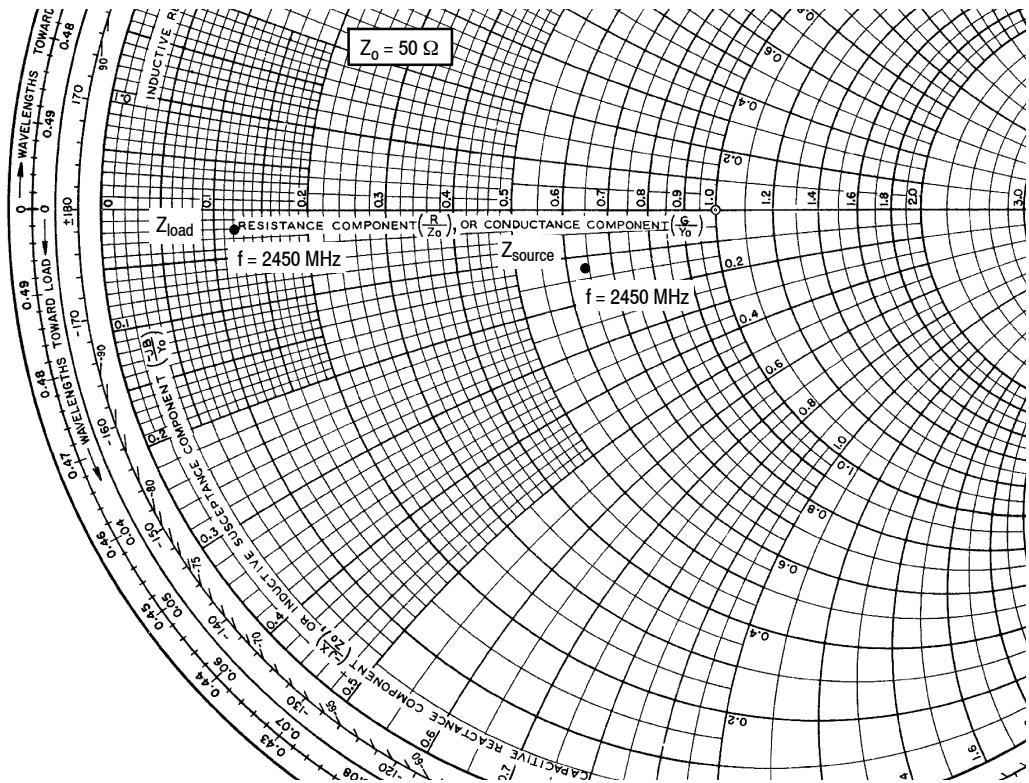

$V_{DD} = 28 \text{ Vdc}$, $I_{DQ1} = 55 \text{ mA}$, $I_{DQ2} = 195 \text{ mA}$, $P_{out} = 25 \text{ W CW}$

f MHz	Z_{source} Ω	Z_{load} Ω
2450	$32 - j6.256$	$6.2 - j1.17$

Z_{source} = Test circuit impedance as measured from gate to ground.

Z_{load} = Test circuit impedance as measured from drain to ground.

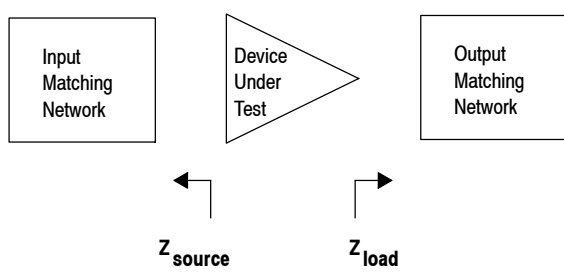
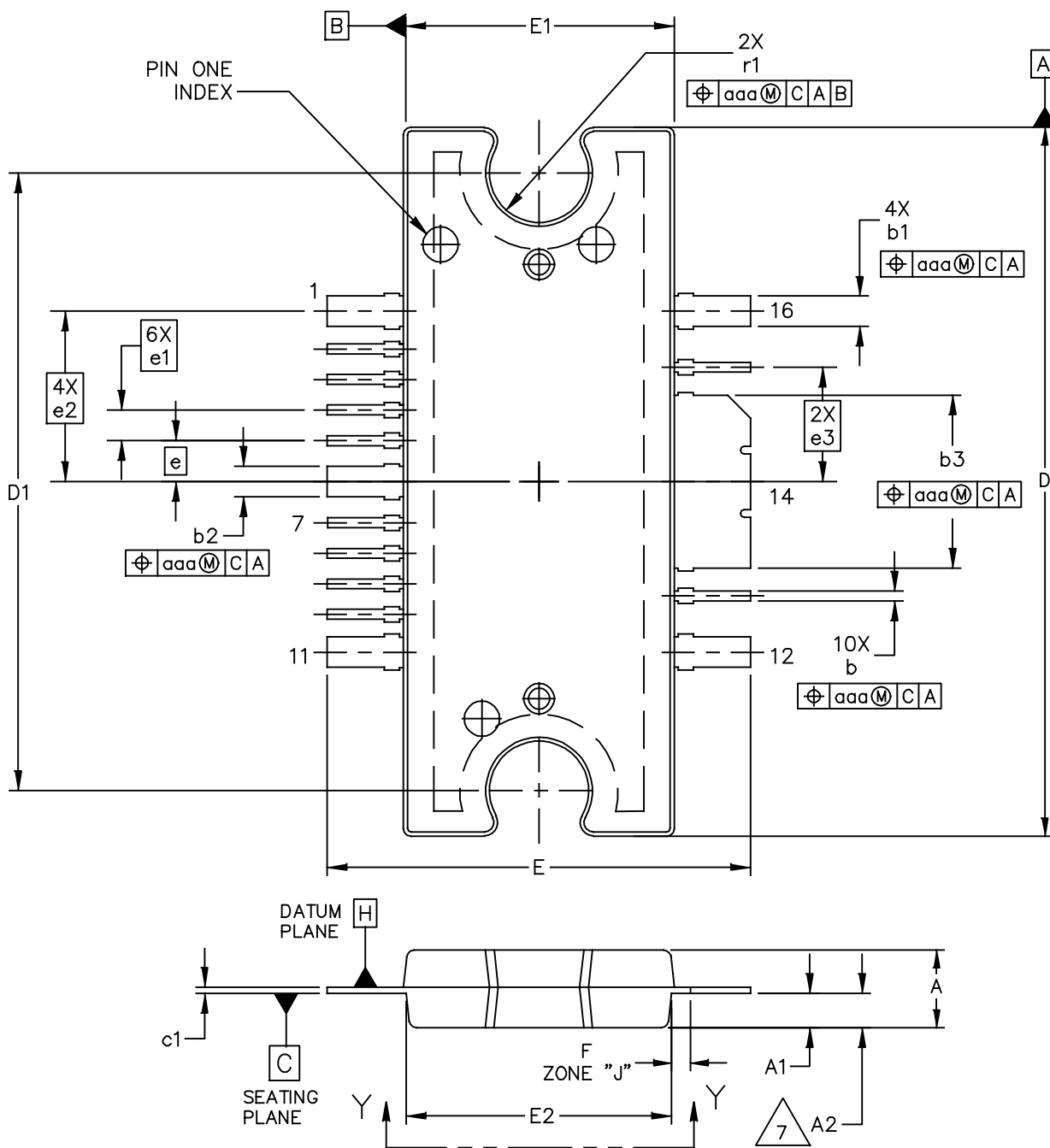
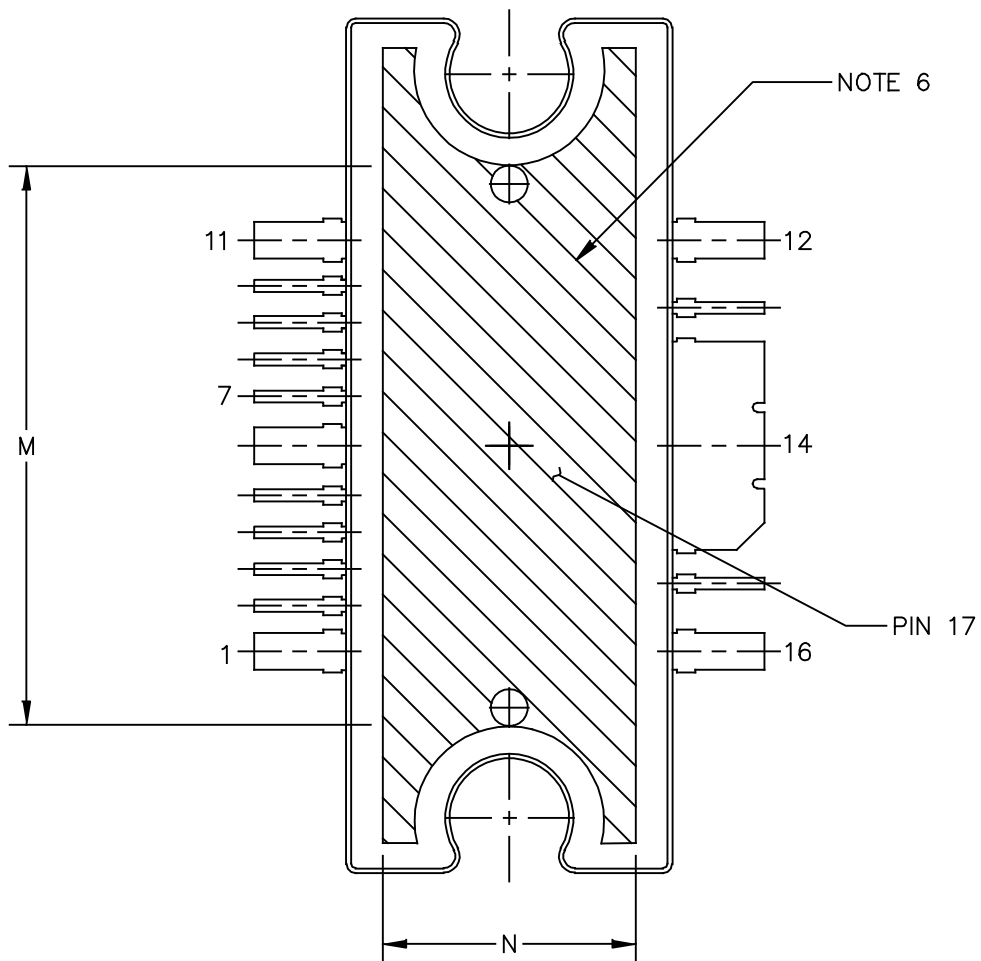

Figure 12. Series Equivalent Source and Load Impedance — Narrowband

PACKAGE DIMENSIONS



© FREESCALE SEMICONDUCTOR, INC. ALL RIGHTS RESERVED.		MECHANICAL OUTLINE		PRINT VERSION NOT TO SCALE	
TITLE: TO-272 WIDE BODY MULTI-LEAD		DOCUMENT NO: 98ARH99164A		REV: M	
		CASE NUMBER: 1329-09		23 AUG 2007	
		STANDARD: NON-JEDEC			



VIEW Y-Y

© FREESCALE SEMICONDUCTOR, INC. ALL RIGHTS RESERVED.	MECHANICAL OUTLINE	PRINT VERSION NOT TO SCALE	
TITLE: TO-272 WIDE BODY MULTI-LEAD	DOCUMENT NO: 98ARH99164A	REV: M	
	CASE NUMBER: 1329-09	23 AUG 2007	
	STANDARD: NON-JEDEC		

NOTES:

1. CONTROLLING DIMENSION: INCH
2. INTERPRET DIMENSIONS AND TOLERANCES PER ASME Y14.5M-1994.
3. DATUM PLANE -H- IS LOCATED AT THE TOP OF LEAD AND IS COINCIDENT WITH THE LEAD WHERE THE LEAD EXITS THE PLASTIC BODY AT THE TOP OF THE PARTING LINE.
4. DIMENSIONS "D" AND "E1" DO NOT INCLUDE MOLD PROTRUSION. ALLOWABLE PROTRUSION IS .006 (0.15) PER SIDE. DIMENSIONS "D" AND "E1" DO INCLUDE MOLD MISMATCH AND ARE DETERMINED AT DATUM PLANE -H-.
5. DIMENSIONS "b", "b1", "b2" AND "b3" DO NOT INCLUDE DAMBAR PROTRUSION. ALLOWABLE DAMBAR PROTRUSION SHALL BE .005 (0.13) TOTAL IN EXCESS OF THE "b", "b1", "b2" AND "b3" DIMENSIONS AT MAXIMUM MATERIAL CONDITION.
6. HATCHING REPRESENTS THE EXPOSED AREA OF THE HEAT SLUG. HATCHED AREA SHOWN IS ON THE SAME PLANE.
7. DIM A2 APPLIES WITHIN ZONE "J" ONLY.

DIM	INCH		MILLIMETER		DIM	INCH		MILLIMETER	
	MIN	MAX	MIN	MAX		MIN	MAX	MIN	MAX
A	.100	.104	2.54	2.64	b	.011	.017	0.28	0.43
A1	.038	.044	0.96	1.12	b1	.037	.043	0.94	1.09
A2	.040	.042	1.02	1.07	b2	.037	.043	0.94	1.09
D	.928	.932	23.57	23.67	b3	.225	.231	5.72	5.87
D1	.810 BSC		20.57 BSC		c1	.007	.011	.18	.28
E	.551	.559	14.00	14.20	e	.054 BSC		1.37 BSC	
E1	.353	.357	8.97	9.07	e1	.040 BSC		1.02 BSC	
E2	.346	.350	8.79	8.89	e2	.224 BSC		5.69 BSC	
F	.025 BSC		0.64 BSC		e3	.150 BSC		3.81 BSC	
M	.600	----	15.24	----	r1	.063	.068	1.6	1.73
N	.270	----	6.86	----	aaa	.004		.10	
© FREESCALE SEMICONDUCTOR, INC. ALL RIGHTS RESERVED.			MECHANICAL OUTLINE			PRINT VERSION NOT TO SCALE			
TITLE: TO-272 WIDE BODY MULTI-LEAD					DOCUMENT NO: 98ARH99164A			REV: M	
					CASE NUMBER: 1329-09			23 AUG 2007	
					STANDARD: NON-JEDEC				

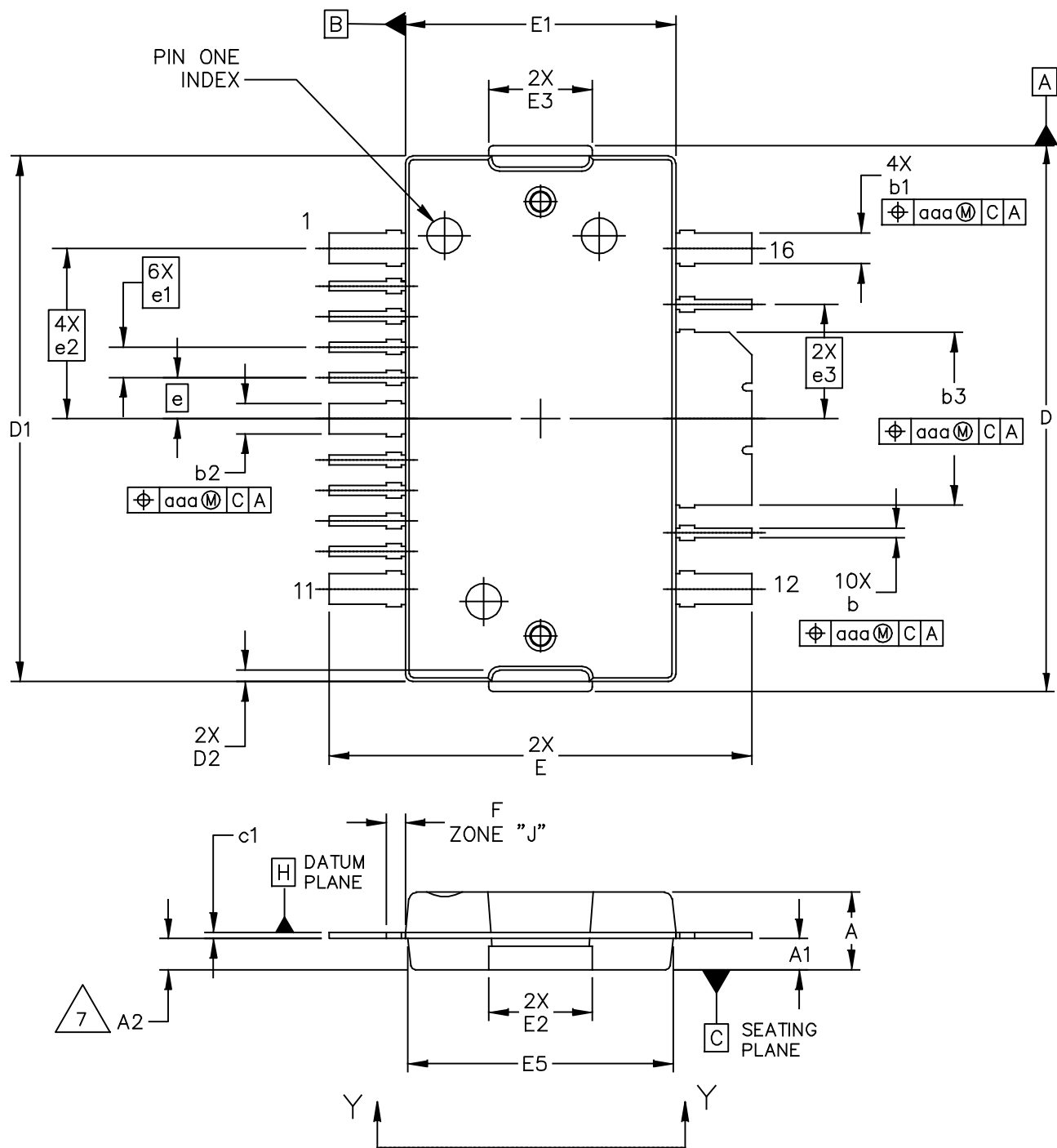

© FREESCALE SEMICONDUCTOR, INC. ALL RIGHTS RESERVED.		MECHANICAL OUTLINE	PRINT VERSION NOT TO SCALE
TITLE: TO-270 WIDE BODY 16 LEAD	DOCUMENT NO: 98ASA10754D		REV: A
	CASE NUMBER: 1886-01		31 AUG 2007
	STANDARD: NON-JEDEC		

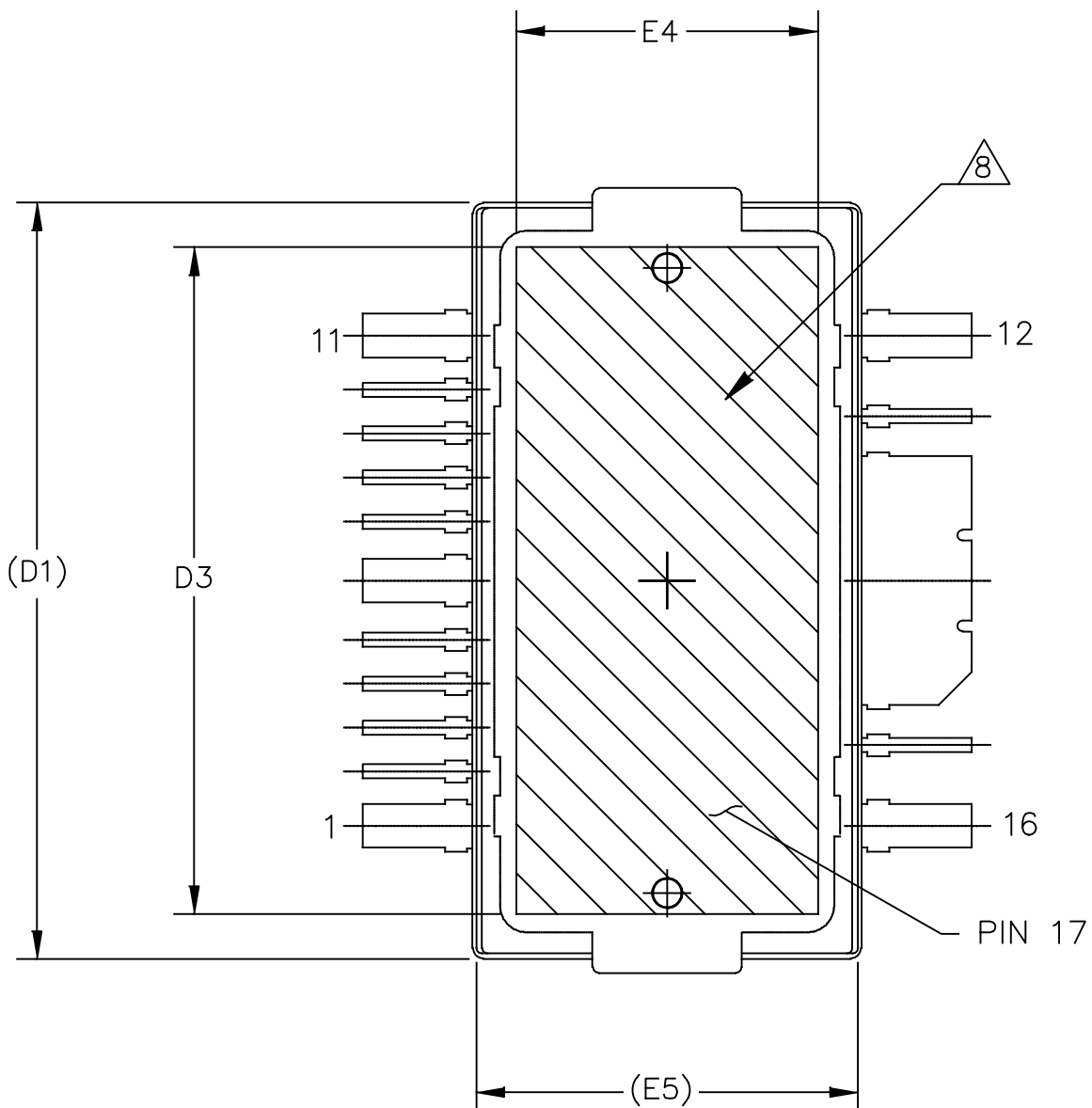

VIEW Y-Y

© FREESCALE SEMICONDUCTOR, INC. ALL RIGHTS RESERVED.	MECHANICAL OUTLINE	PRINT VERSION NOT TO SCALE	
TITLE: TO-270 WIDE BODY 16 LEAD	DOCUMENT NO: 98ASA10754D	REV: A	
	CASE NUMBER: 1886-01	31 AUG 2007	
	STANDARD: NON-JEDEC		

MHT2000NR1 MHT2000GNR1

NOTES:

1. CONTROLLING DIMENSION: INCH
2. INTERPRET DIMENSIONS AND TOLERANCES PER ASME Y14.5M-1994.
3. DATUM PLANE -H- IS LOCATED AT THE TOP OF LEAD AND IS COINCIDENT WITH THE LEAD WHERE THE LEAD EXITS THE PLASTIC BODY AT THE TOP OF THE PARTING LINE.
4. DIMENSIONS "D" AND "E1" DO NOT INCLUDE MOLD PROTRUSION. ALLOWABLE PROTRUSION IS .006 (0.15) PER SIDE. DIMENSIONS "D" AND "E1" DO INCLUDE MOLD MISMATCH AND ARE DETERMINED AT DATUM PLANE -H-.
5. DIMENSIONS "b", "b1", "b2" AND "b3" DO NOT INCLUDE DAMBAR PROTRUSION. ALLOWABLE DAMBAR PROTRUSION SHALL BE .005 (0.13) TOTAL IN EXCESS OF THE "b", "b1", "b2" AND "b3" DIMENSIONS AT MAXIMUM MATERIAL CONDITION.
6. DATUM -A- AND -B- TO BE DETERMINED AT DATUM PLANE -H-.
7. DIMENSION A2 APPLIES WITHIN ZONE "J" ONLY.
8. HATCHING REPRESENTS THE EXPOSED AREA OF THE HEAT SLUG. HATCHED AREA SHOWN IS ON THE SAME PLANE.

DIM	INCH		MILLIMETER		DIM	INCH		MILLIMETER	
	MIN	MAX	MIN	MAX		MIN	MAX	MIN	MAX
A	.100	.104	2.54	2.64	F	.025 BSC		0.64 BSC	
A1	.039	.043	0.99	1.09	b	.011	.017	0.28	0.43
A2	.040	.042	1.02	1.07	b1	.037	.043	0.94	1.09
D	.712	.720	18.08	18.29	b2	.037	.043	0.94	1.09
D1	.688	.692	17.48	17.58	b3	.225	.231	5.72	5.87
D2	.011	.019	0.28	0.48	c1	.007	.011	.18	.28
D3	.600	---	15.24	---	e	.054 BSC		1.37 BSC	
E	.551	.559	14	14.2	e1	.040 BSC		1.02 BSC	
E1	.353	.357	8.97	9.07	e2	.224 BSC		5.69 BSC	
E2	.132	.140	3.35	3.56	e3	.150 BSC		3.81 BSC	
E3	.124	.132	3.15	3.35	aaa	.004		.10	
E4	.270	---	6.86	---					
E5	.346	.350	8.79	8.89					
© FREESCALE SEMICONDUCTOR, INC. ALL RIGHTS RESERVED.			MECHANICAL OUTLINE			PRINT VERSION NOT TO SCALE			
TITLE: TO-270 WIDE BODY 16 LEAD					DOCUMENT NO: 98ASA10754D			REV: A	
					CASE NUMBER: 1886-01			31 AUG 2007	
					STANDARD: NON-JEDEC				

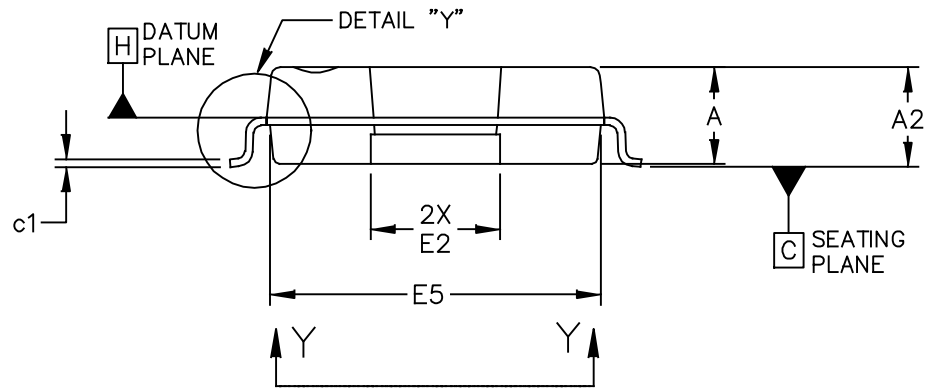
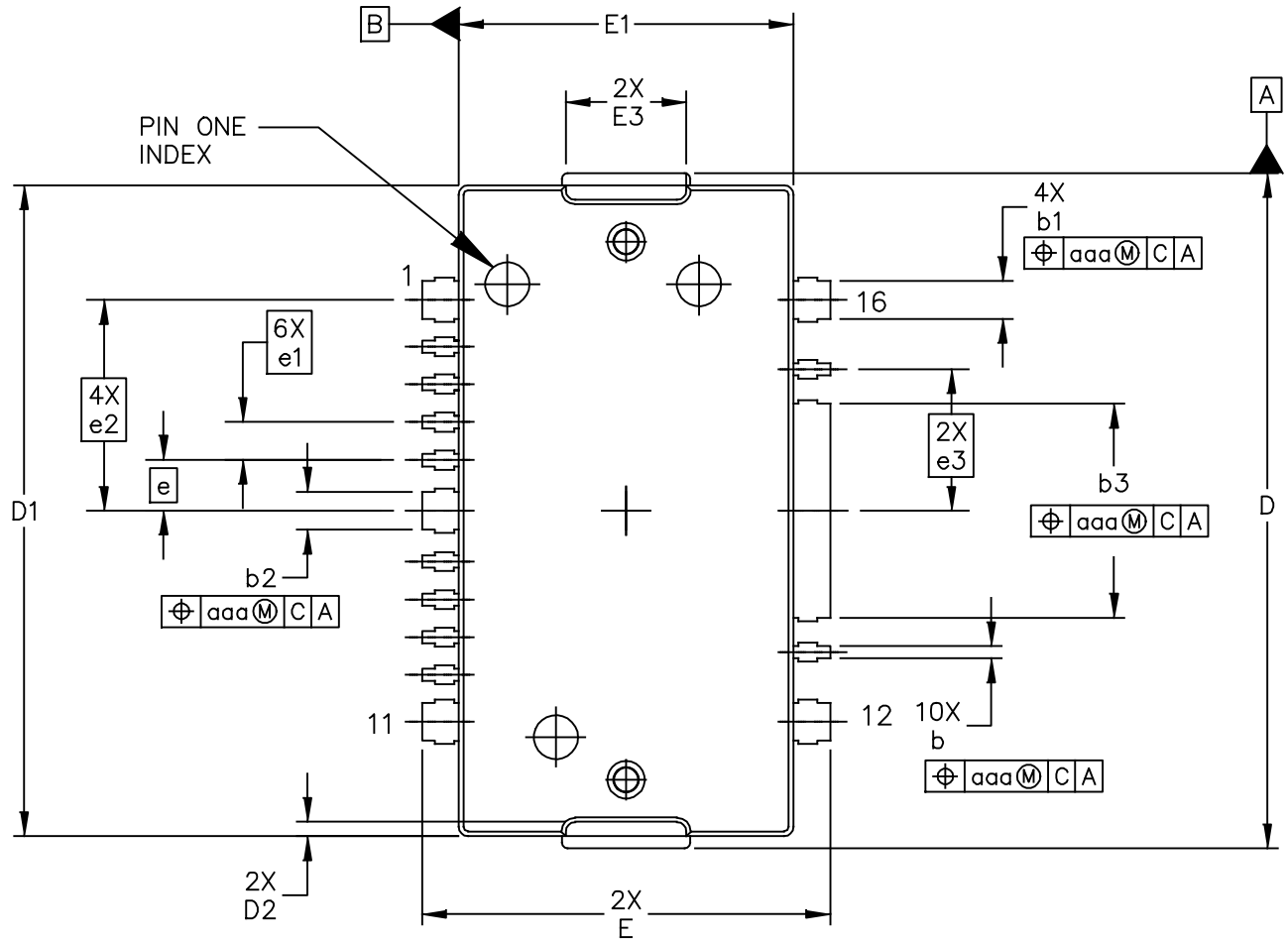

© FREESCALE SEMICONDUCTOR, INC. ALL RIGHTS RESERVED.		MECHANICAL OUTLINE		PRINT VERSION NOT TO SCALE	
TITLE: TO-270 WIDE BODY 16 LEAD, GULL WING	DOCUMENT NO: 98ASA10755D		REV: A		
	CASE NUMBER: 1887-01		31 AUG 2007		
	STANDARD: NON-JEDEC				

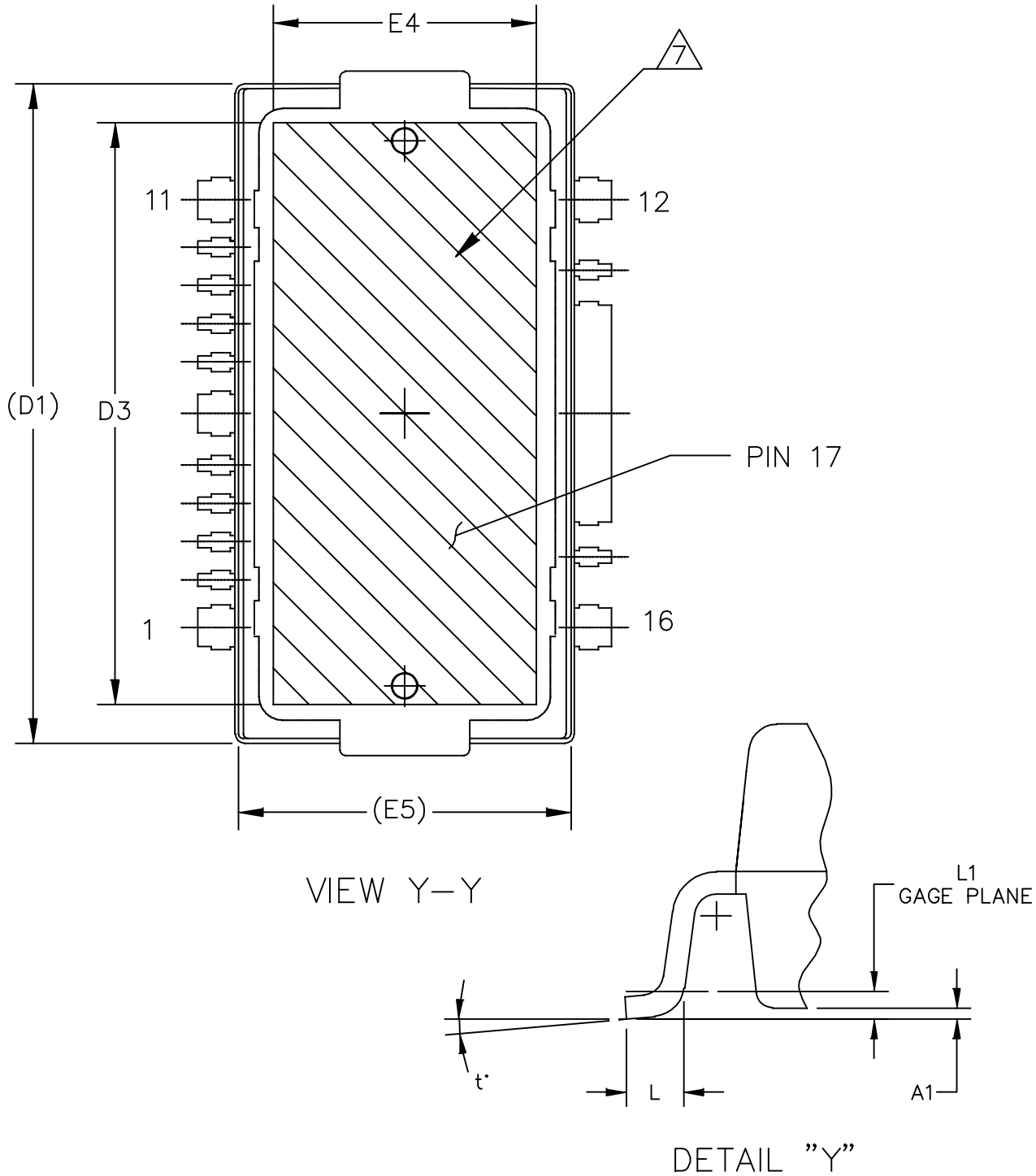

© FREESCALE SEMICONDUCTOR, INC. ALL RIGHTS RESERVED.		MECHANICAL OUTLINE	PRINT VERSION NOT TO SCALE
TITLE: TO-270 WIDE BODY 16 LEAD, GULL WING	DOCUMENT NO: 98ASA10755D		REV: A
	CASE NUMBER: 1887-01		31 AUG 2007
	STANDARD: NON-JEDEC		

NOTES:

1. CONTROLLING DIMENSION: INCH
2. INTERPRET DIMENSIONS AND TOLERANCES PER ASME Y14.5M-1994.
3. DATUM PLANE -H- IS LOCATED AT THE TOP OF LEAD AND IS COINCIDENT WITH THE LEAD WHERE THE LEAD EXITS THE PLASTIC BODY AT THE TOP OF THE PARTING LINE.
4. DIMENSIONS "D" AND "E1" DO NOT INCLUDE MOLD PROTRUSION. ALLOWABLE PROTRUSION IS .006 (0.15) PER SIDE. DIMENSIONS "D" AND "E1" DO INCLUDE MOLD MISMATCH AND ARE DETERMINED AT DATUM PLANE -H-.
5. DIMENSIONS "b", "b1", "b2" AND "b3" DO NOT INCLUDE DAMBAR PROTRUSION. ALLOWABLE DAMBAR PROTRUSION SHALL BE .005 (0.13) TOTAL IN EXCESS OF THE "b", "b1", "b2" AND "b3" DIMENSIONS AT MAXIMUM MATERIAL CONDITION.
6. DATUM -A- AND -B- TO BE DETERMINED AT DATUM PLANE -H-.
7. HATCHING REPRESENTS EXPOSED AREA OF THE HEAT SLUG. HATCHED AREA SHOWN IS ON THE SAME PLANE.

DIM	INCH		MILLIMETER		DIM	INCH		MILLIMETER	
	MIN	MAX	MIN	MAX		MIN	MAX	MIN	MAX
A	.100	.104	2.54	2.64	L	.018	.024	0.46	0.61
A1	.001	.004	0.02	0.10	L1	.010 BSC		0.25 BSC	
A2	.099	.110	2.51	2.79	b	.011	.017	0.28	0.43
D	.712	.720	18.08	18.29	b1	.037	.043	0.94	1.09
D1	.688	.692	17.48	17.58	b2	.037	.043	0.94	1.09
D2	.011	.019	0.28	0.48	b3	.225	.231	5.72	5.87
D3	.600	---	15.24	---	c1	.007	.011	0.18	0.28
E	.429	.437	10.9	11.1	e	.054 BSC		1.37 BSC	
E1	.353	.357	8.97	9.07	e1	.040 BSC		1.02 BSC	
E2	.132	.140	3.35	3.56	e2	.224 BSC		5.69 BSC	
E3	.124	.132	3.15	3.35	e3	.150 BSC		3.81 BSC	
E4	.270	---	6.86	---	t	2'	8'	2'	8'
E5	.346	.350	8.79	8.89	aaa	.004		0.10	
© FREESCALE SEMICONDUCTOR, INC. ALL RIGHTS RESERVED.			MECHANICAL OUTLINE			PRINT VERSION NOT TO SCALE			
TITLE: TO-270 WIDE BODY 16 LEAD, GULL WING					DOCUMENT NO: 98ASA10755D			REV: A	
					CASE NUMBER: 1887-01			31 AUG 2007	
					STANDARD: NON-JEDEC				

PRODUCT DOCUMENTATION AND SOFTWARE

Refer to the following resources to aid your design process.

Application Notes

- AN1907: Solder Reflow Attach Method for High Power RF Devices in Plastic Packages
- AN1955: Thermal Measurement Methodology of RF Power Amplifiers
- AN1977: Quiescent Current Thermal Tracking Circuit in the RF Integrated Circuit Family
- AN1987: Quiescent Current Control for the RF Integrated Circuit Device Family
- AN3789: Clamping of High Power RF Transistors and RFICs in Over-Molded Plastic Packages

Engineering Bulletins

- EB212: Using Data Sheet Impedances for RF LDMOS Devices

Software

- Electromigration MTTF Calculator

For Software, do a Part Number search at <http://www.freescale.com>, and select the “Part Number” link. Go to the Software & Tools tab on the part’s Product Summary page to download the respective tool.

REVISION HISTORY

The following table summarizes revisions to this document.

Revision	Date	Description
0	May 2014	• Initial Release of Data Sheet

APPENDIX A MHT2000NR1 FUNCTIONAL TEST DATA, FIXTURE AND THERMAL DATA

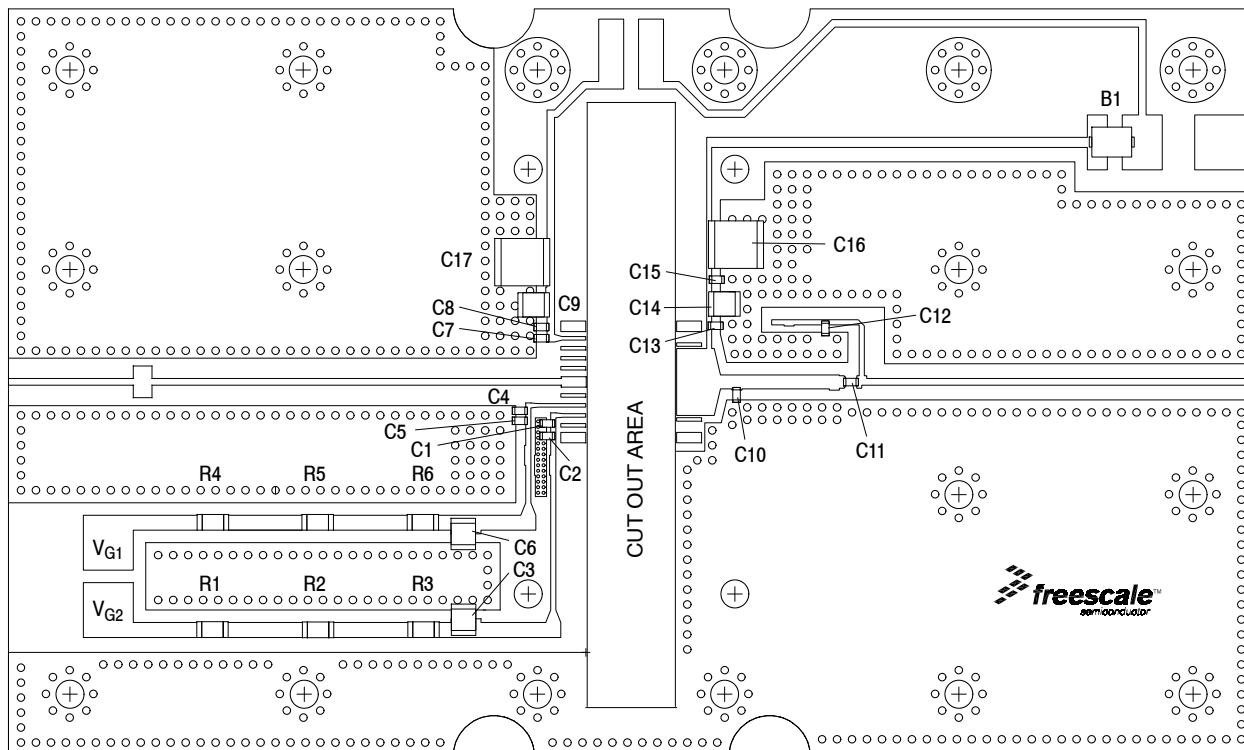

Z1	0.500" x 0.027" Microstrip	Z9	0.040" x 0.061" Microstrip
Z2	0.075" x 0.127" Microstrip	Z10	0.020" x 0.050" Microstrip
Z3	1.640" x 0.027" Microstrip	Z11	0.050" x 0.050" Microstrip
Z4	0.100" x 0.042" Microstrip	Z12	0.050" x 0.027" Microstrip
Z5	0.151" x 0.268" Microstrip	Z13*	0.338" x 0.020" Microstrip
Z6	0.025" x 0.268" x 0.056" Taper	Z14	1.551" x 0.027" Microstrip
Z7	0.050" x 0.056" Microstrip	PCB	Rogers R04350B, 0.0133", $\epsilon_r = 3.48$
Z8	0.356" x 0.056" Microstrip		

* Line length includes microstrip bends

Figure A-1. MHT2000NR1 Test Circuit Component Layout

Table A-1. Electrical Characteristics ($T_C = 25^\circ\text{C}$ unless otherwise noted)

Characteristic	Symbol	Min	Typ	Max	Unit
Functional Tests (In Freescale Test Fixture, 50 ohm system) $V_{DD} = 28\text{ Vdc}$, $I_{DQ1} = 77\text{ mA}$, $I_{DQ2} = 275\text{ mA}$, $P_{out} = 4\text{ W Avg.}$, $f = 2700\text{ MHz}$, WiMAX, OFDM 802.16d, 64 QAM $3/4$, 4 Bursts, 10 MHz Channel Bandwidth, Input Signal PAR = 9.5 dB @ 0.01% Probability on CCDF. ACPR measured in 1 MHz Channel Bandwidth @ $\pm 8.5\text{ MHz}$ Offset.					
Power Gain	G_{ps}	25.5	28.5	30.5	dB
Power Added Efficiency	PAE	15	17	—	%
Output Peak-to-Average Ratio @ 0.01% Probability on CCDF	PAR	—	9	—	dB
Adjacent Channel Power Ratio	ACPR	—	-50	-46	dBc
Input Return Loss	IRL	—	-15	-10	dB

(continued)

APPENDIX A
MHT2000NR1 FUNCTIONAL TEST DATA, FIXTURE AND THERMAL DATA (continued)

Table A-1. Electrical Characteristics ($T_C = 25^\circ\text{C}$ unless otherwise noted) **(continued)**

Characteristic	Symbol	Min	Typ	Max	Unit
Stage 1 - On Characteristics					
Gate Quiescent Voltage ($V_{DS} = 28\text{ Vdc}$, $I_{DQ1} = 77\text{ mA}$)	$V_{GS(Q)}$	—	2.7	—	Vdc
Fixture Gate Quiescent Voltage ($V_{DD} = 28\text{ Vdc}$, $I_{DQ1} = 77\text{ mAdc}$, Measured in Functional Test)	$V_{GG(Q)}$	12.5	15.8	19.5	Vdc
Stage 2 - On Characteristics					
Gate Quiescent Voltage ($V_{DS} = 28\text{ Vdc}$, $I_{DQ2} = 275\text{ mAdc}$)	$V_{GS(Q)}$	—	2.7	—	Vdc
Fixture Gate Quiescent Voltage ($V_{DD} = 28\text{ Vdc}$, $I_{DQ2} = 275\text{ mAdc}$, Measured in Functional Test)	$V_{GG(Q)}$	11	14	18	Vdc

Table A-2. Thermal Characteristics

Characteristic	Symbol	Value	Unit
Thermal Resistance, Junction to Case (Case Temperature 81°C , $P_{out} = 25\text{ W CW}$)	$R_{\theta JC}$	Stage 1, 28 Vdc, $I_{DQ1} = 77\text{ mA}$	5.5
		Stage 2, 28 Vdc, $I_{DQ2} = 275\text{ mA}$	1.3

How to Reach Us:

Home Page:
freescale.com

Web Support:
freescale.com/support

Information in this document is provided solely to enable system and software implementers to use Freescale products. There are no express or implied copyright licenses granted hereunder to design or fabricate any integrated circuits based on the information in this document.

Freescale reserves the right to make changes without further notice to any products herein. Freescale makes no warranty, representation, or guarantee regarding the suitability of its products for any particular purpose, nor does Freescale assume any liability arising out of the application or use of any product or circuit, and specifically disclaims any and all liability, including without limitation consequential or incidental damages. "Typical" parameters that may be provided in Freescale data sheets and/or specifications can and do vary in different applications, and actual performance may vary over time. All operating parameters, including "typicals," must be validated for each customer application by customer's technical experts. Freescale does not convey any license under its patent rights nor the rights of others. Freescale sells products pursuant to standard terms and conditions of sale, which can be found at the following address: freescale.com/SalesTermsandConditions.

Freescale and the Freescale logo are trademarks of Freescale Semiconductor, Inc., Reg. U.S. Pat. & Tm. Off. All other product or service names are the property of their respective owners.

© 2014 Freescale Semiconductor, Inc.

Looking for pricing, stock, or lifecycle information?

Click below to explore more details on WIN SOURCE:

 [View MHT2000NR1](#) on WIN SOURCE

 [NXP / Nexperia](#) Information

Optimize Your Supply Chain with WIN SOURCE Solutions

-  Global Sourcing Solution
-  Obsolete Management
-  Cost Control Management
-  Shortage Management
-  Alternative Solution
-  Excess Inventory Management