

P	LTR	DESCRIPTION	DATE	DWN	APVD
B		ECO-06-028040	30NOV2006	LAM	JW
C		REVISED PER ECN-21-104603	25MAY2021	AK	SZ
CI		REVISED PER ECN-24-292270	16OCT2024	TR	KR

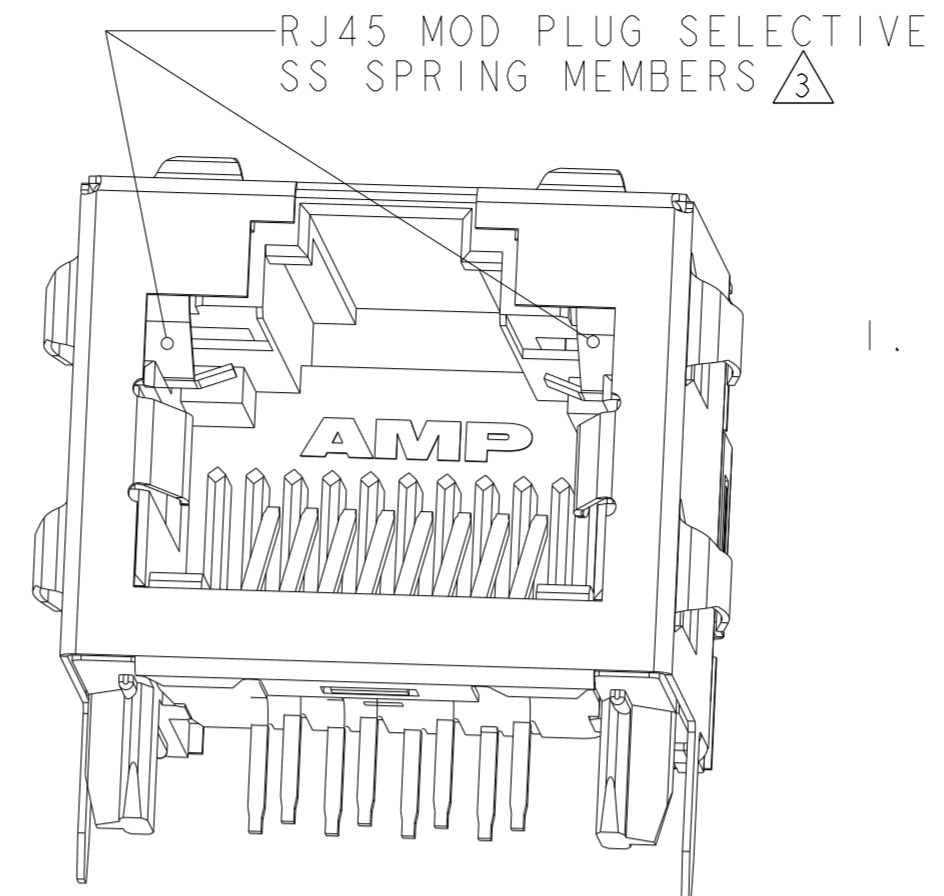
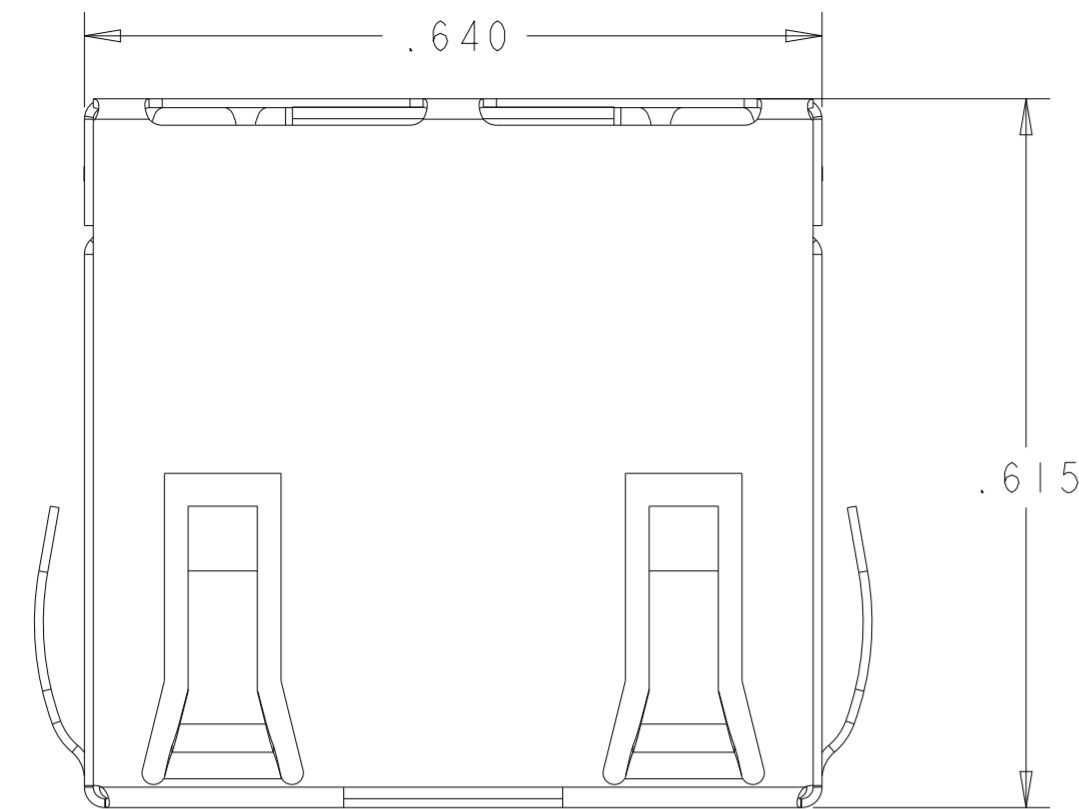

1. MATERIAL:  
 HOUSING -- COLOR: BLACK, HIGH TEMPERATURE THERMOPLASTIC, PER UL94V-0; IR REFLOW SOLDERING PROCESS COMPATIBLE.

TERMINALS -- .014 THICK PHOSPHOR BRONZE PLATING -- .000050 INCHES GOLD IN CONTACT AREA, .000150 INCHES MATTE TIN ON SOLDER TAILS, ALL OVER .000050 INCHES OF NICKEL.

SHIELD -- .0077 THICK COPPER ZINC ALLOY, PREPLATED WITH .000050 INCHES MIN SATIN NICKEL WITH .000080 INCHES MIN TIN POST DIPPED ON PCB GROUND TABS.

2. JACK CAVITY CONFORMS TO FCC RULES AND REGULATIONS PART 68, SUBPART F.

3. RJ45 MOD PLUG SELECTIVE -- THIS CONNECTOR UTILIZES 2 STAINLESS STEEL SPRING MEMBERS WHICH PREVENT THE INSERTION OF A RJ11 (6 POSITION) PLUG INTO THE JACK PORT, WHILE ALLOWING A RJ45 (8 POSITION) PLUG TO MATE FREELY.

WARNING: THIS FEATURE WAS DEVELOPED FOR TYPICAL PLUG INSERTION FORCES. EXCESSIVE INSERTION FORCE MAY OVERCOME THE SELECTIVE FEATURES AND DAMAGE THE CONNECTOR.

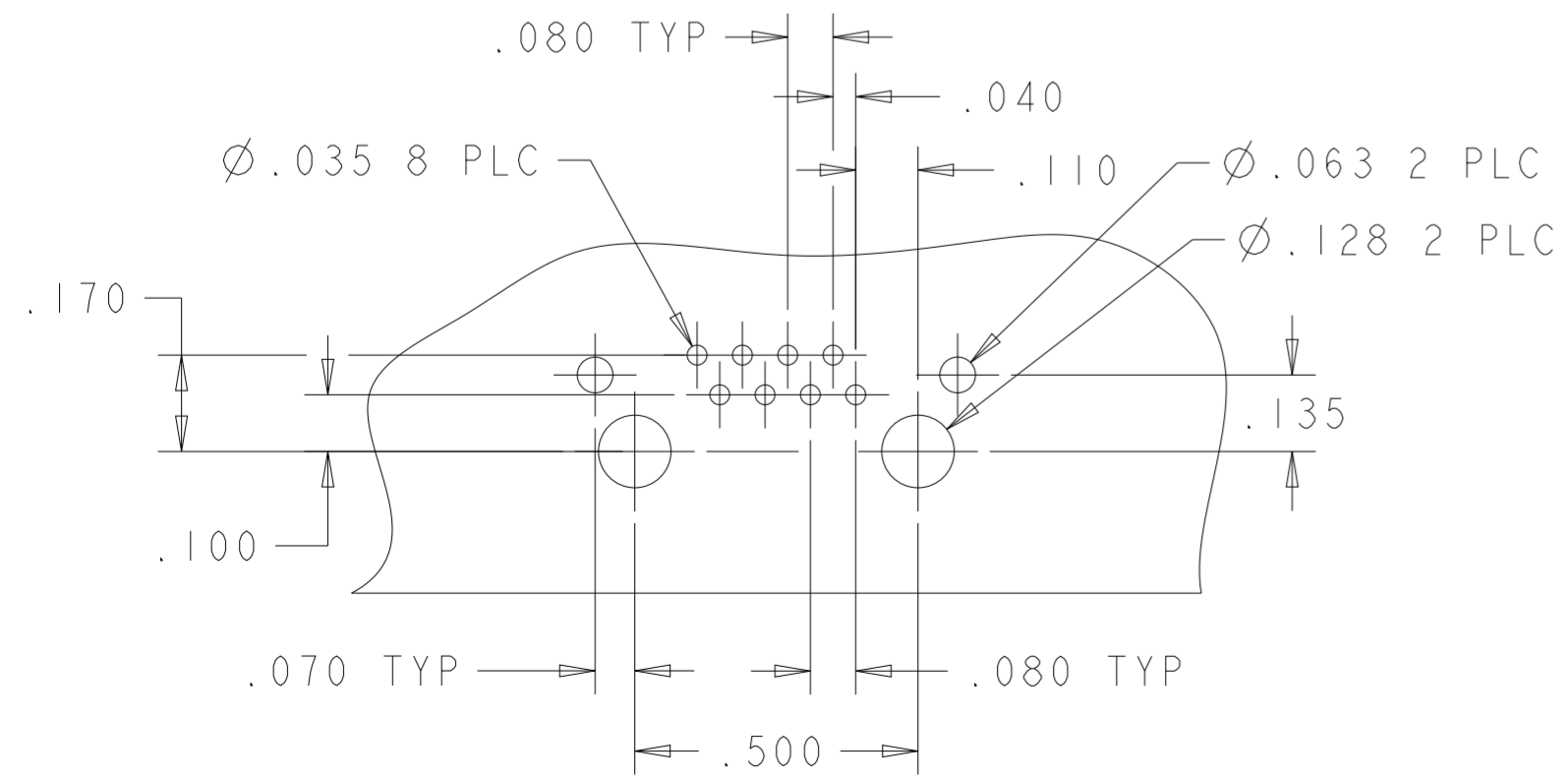
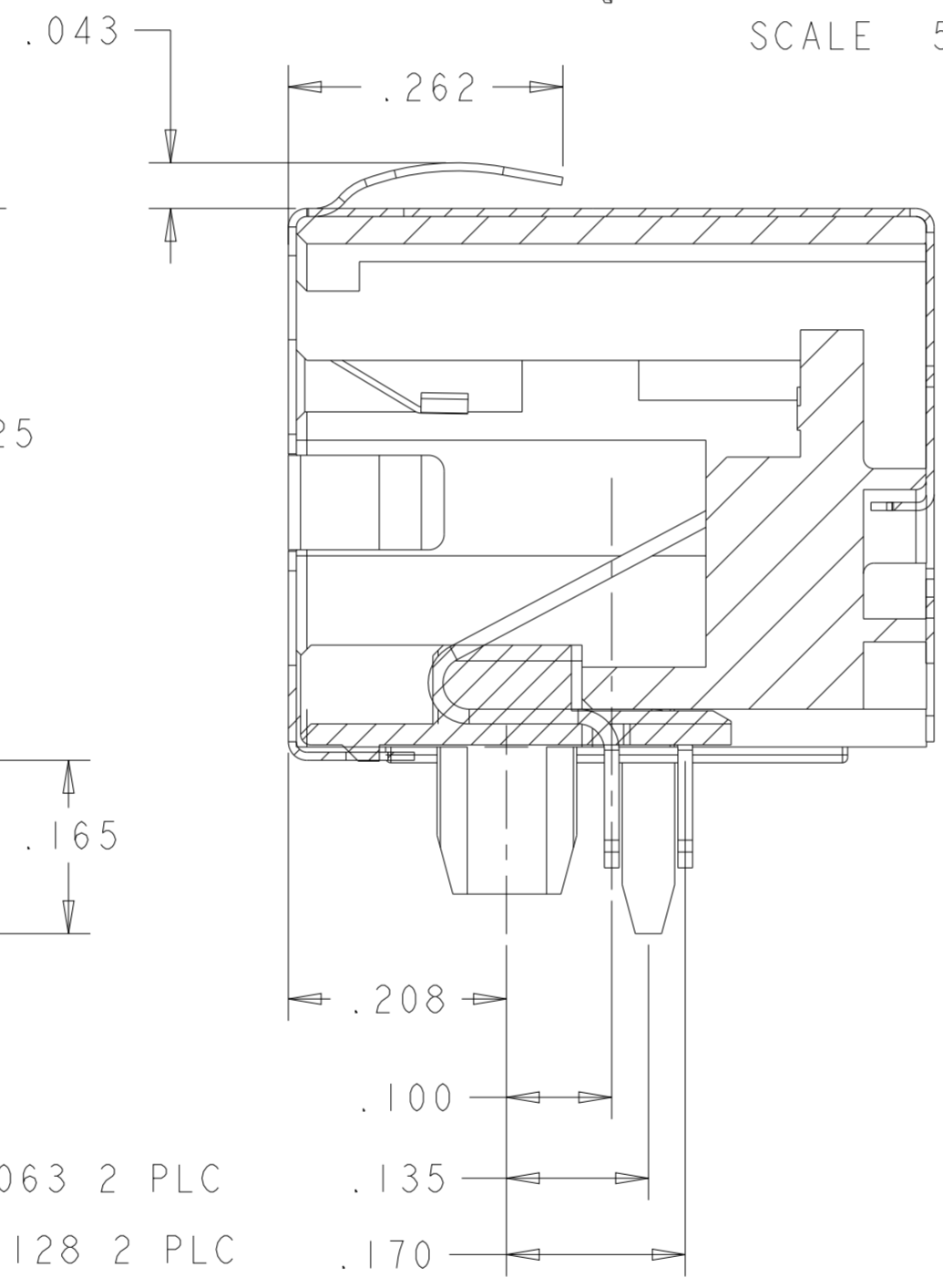
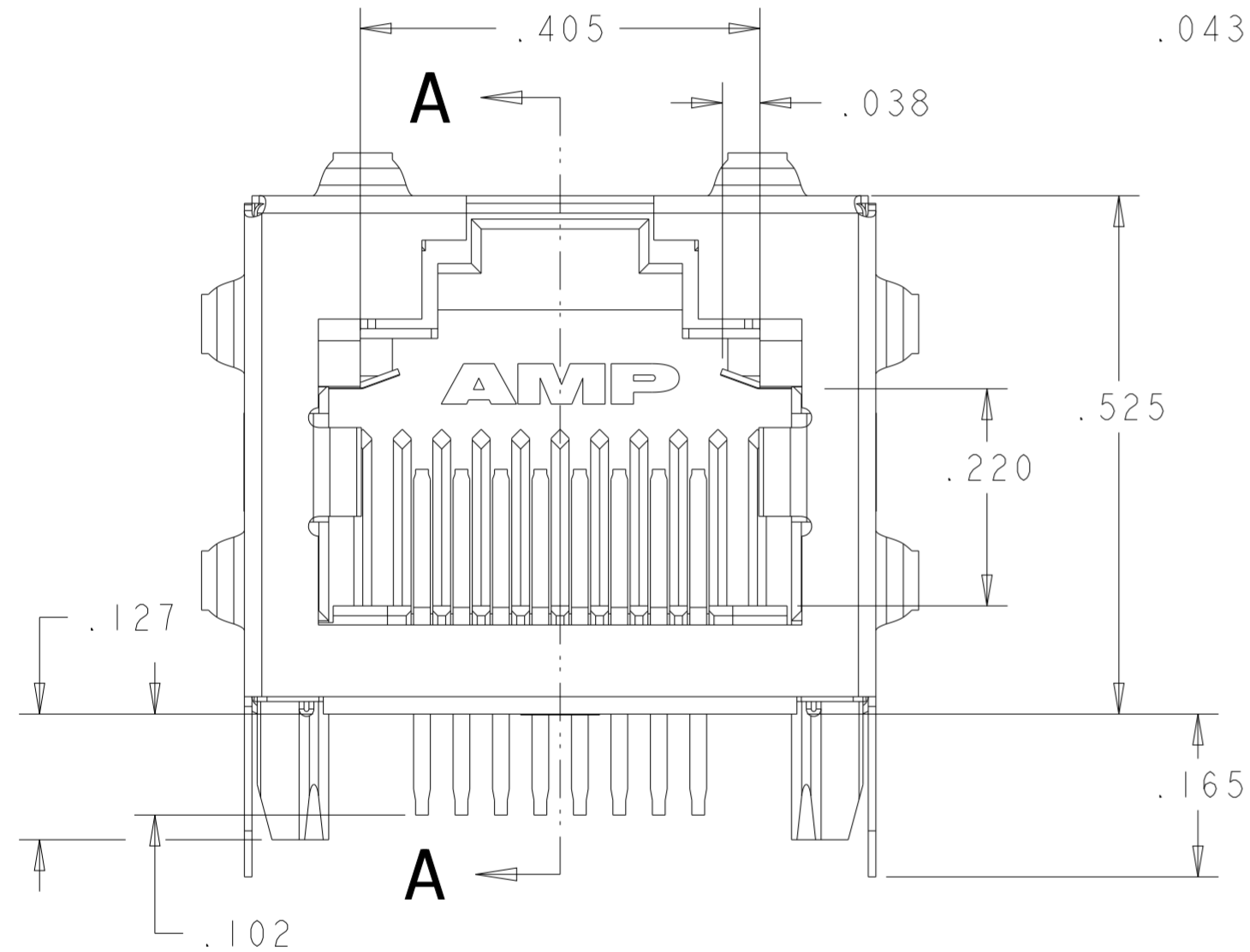

PCB VIEWED THRU CONNECTOR SCALE 3:1

SECTION A-A

THIS DRAWING IS A CONTROLLED DOCUMENT.		DWN A. MAYER 09MAY2005	TE Connectivity	
DIMENSIONS: INCHES		CHK J. WESTMAN 09MAY2005		
TOLERANCES UNLESS OTHERWISE SPECIFIED:		APVD S. FLICKINGER 09MAY2005	NAME INVERTED MOD JACK ASSEMBLY, 1 X 1, SHIELDED, PANEL GROUNDS, RJ45 MOD PLUG SELECTIVE CAPABILITY	
0 PLC ±		PRODUCT SPEC 108-1163-4	SIZE A2	
1 PLC ±		APPLICATION SPEC 114-2154	CAGE CODE 00779	
2 PLC ±		WEIGHT -	DRAWING NO C-6364288	
3 PLC ±.013		RESTRICTED TO		
4 PLC ±		SCALE 2:1 SHEET 1 OF 1 REV C1		
ANGLES ±		CUSTOMER DRAWING		
FINISH SEE NOTE 1				

Looking for pricing, stock, or lifecycle information?

Click below to explore more details on WIN SOURCE:

[View 6364288-4 on WIN SOURCE](#)

[TE Connectivity Information](#)

### Optimize Your Supply Chain with WIN SOURCE Solutions

- ✓ Global Sourcing Solution
- ✓ Obsolete Management
- ✓ Cost Control Management
- ✓ Shortage Management
- ✓ Alternative Solution
- ✓ Excess Inventory Management