



## SPECIFICATION RW-2511

TE 108-121014

### TMS-SCE, TMS-CT and TTMS (MP) HEAT SHRINK MARKER SLEEVES

#### SCOPE

**This specification establishes the quality standard for heat shrinkable identification markers, for use in multipurpose and military applications. The special requirements for military applications are detailed in Table 4.**

The operating temperature for this product is -55°C to +135°C (-67 to +275°F).

This system is a computerised method of identifying items by printing a mark on TMS-SCE, TMS-CT and TTMS product ranges. The mark is permanent upon printing. This system is not recommended where strain relief properties are required.

TMS-SCE and TTMS are available in both 2:1 (e.g. TMS-SCE-2X) and 3:1 (e.g. TMS-SCE) shrink ratio (see Tables 1 and 2 for more details). TMS-CT is only available as a 3:1 product.

The marker system comprises specific printers and ribbons (refer to Identification Printer Product Ribbon Matrix Document 411-121005). Products printed with black or silver ribbons as specified in 411-121005 fully comply with this specification. Products printed with white ribbon may not fully meet the specified print performance when exposed to some aggressive fluids, details on page 22. Compliance to this specification can only be guaranteed if TE Connectivity approved printers and ribbons are used.

Laser markable using industrial standard YAG lasers.

The tube size for qualification testing is 1/4inch (6.4mm) as supplied internal diameter with both 2:1 and 3:1 shrink ratio unless otherwise specified.

**THIS IS A CLASS 1 DOCUMENT WHICH IS NONCONFIDENTIAL.**

*The information contained within this document is the property of TE Connectivity. It is supplied in confidence and the commercial security of the contents must be maintained. It must not be used for any purpose other than that for which it is supplied nor, may any information contained in it be disclosed to unauthorised persons. It must not be reproduced in whole or in part without obtaining written permission from TE Connectivity (TE).*

While TE has made every reasonable effort to ensure the accuracy of the information in this standard, TE does not guarantee that it is error-free, nor does TE make any other representation, warranty or guarantee that the information is accurate, correct, reliable or current. TE reserves the right to make any adjustments to the information contained herein at any time without notice. TE expressly disclaims all implied warranties regarding the information contained herein, including, but not limited to, any implied warranties of merchantability or fitness for a particular purpose. The dimensions in this standard are for reference purposes only and are subject to change without notice. Specifications are subject to change without notice. Consult TE for the latest dimensions and design specifications.

\*Trademark. TE Connectivity, TE connectivity (logo), and TE (logo) are trademarks. Other logos, product and/or company names may be trademarks of their respective owners.



## Table of Contents

1	Composition, appearance and color.....	3
2	Dimension.....	3
3	Test requirement .....	6
4	Test methods.....	6
5	Related documents.....	14
6	Storage conditions.....	16
7	Packaging.....	16
8	Shelf life.....	16
9	Table 3: General requirements for identification products .....	17
10	Table 4: Specific requirements for TMS family heat shrink sleeving.....	20
11	Test Fluids .....	22



**1 COMPOSITION, APPEARANCE AND COLOR**

The sleeving shall be fabricated from irradiated, thermally-stabilised polyolefin compound. It shall be homogeneous and essentially free from flaws, defects, pinholes, bubbles, seams, cracks or inclusions. The marker sleeves shall be white or yellow as standard, other colors available on request.

**2 DIMENSION**

The product shall be supplied in one of the following formats:

- TMS-SCE 3:1 shrink ratio (except 1-1/2 and 2”) in ladder format as shown in figure 1 and to the dimensions of Table 1.
- TMS-SCE-2X Ladder format, 2:1 shrink ratio as shown in figure 1 and to dimensions in table 2.
- TTMS (-MP) & TMS-CT Spooled continuous tubing as shown in figure 2 3:1 shrink ratio (except 1-1/2 and 2”) to the dimensions in Table 1.
- TTMS-2X Spooled continuous tubing as shown in figure 2, 2:1 shrink ratio, to the dimensions in Table 2.

**FIGURE 1: TMS-SCE & TMS-SCE-2X FORMAT**

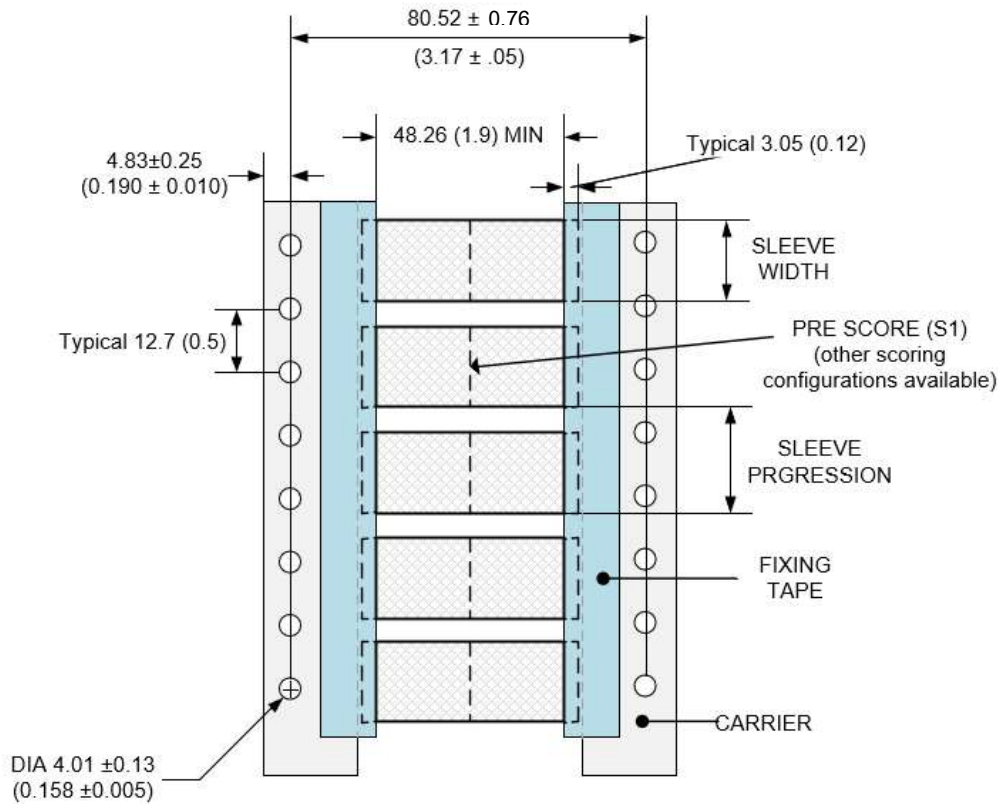

Dimensions in mm (inch)



Figure 2: TMS-CT and TTMS product

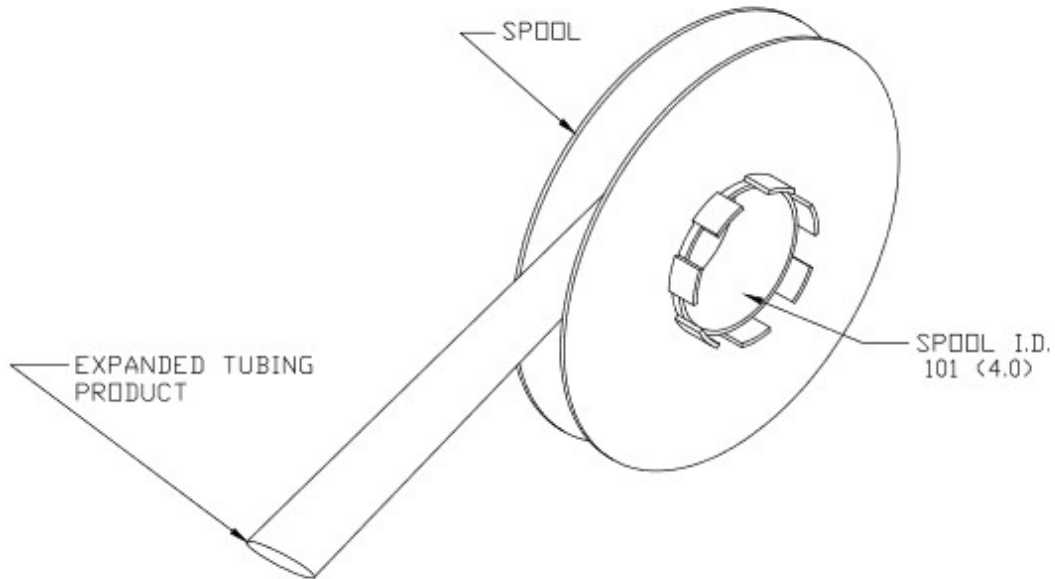
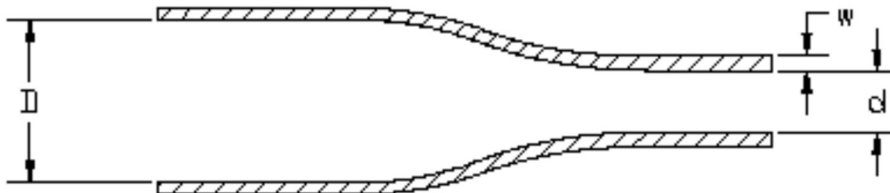

Figure 3: Product Dimensions Change During Recovery



Heat Shrink Product in as Supplied “D” (Expanded) and in the Recovered State “d”.



**Table 1. Product Dimensions TMS-SCE, TMS-CT and TTMS (MP<sup>1</sup>)**

Part Description	“D” Minimum Supplied Inside Diameter mm (inches)	“d” Maximum Recovered Inside Diameter mm (inches)	“w” Wall Thickness After Recovery mm (inches)	Minimum Sleeve Flattened Width mm (inches)	Sleeve Progression <sup>2</sup> mm (inches)	Nominal Weight of single sleeve (~50mm long) grams
TMS-SCE-3/32	2.36 (.093)	0.79 (.031)	0.58 ± 0.08 (.023 ± .003)	4.45 (.175)	12.70 ± 0.89 (.500 ± .035)	0.15
TMS-SCE-1/8	3.18 (.125)	1.07 (.042)	0.58 ± 0.08 (.023 ± .003)	5.84 (.230)	12.70 ± 0.89 (.500 ± .035)	0.20
TMS-SCE-3/16	4.75 (.187)	1.57 (.062)	0.58 ± 0.08 (.023 ± .003)	8.00 (.315)	12.70 ± 0.89 (.500 ± .035)	0.27
TMS-SCE-1/4	6.35 (.250)	2.11 (.083)	0.58 ± 0.08 (.023 ± .003)	10.7 (.420)	16.94 ± 0.89 (.667 ± .035)	0.35
TMS-SCE-3/8	9.53 (.375)	3.18 (.125)	0.61 ± 0.08 (.024 ± .003)	15.5 (.610)	25.40 ± 1.14 (1.00 ± .045)	0.50
TMS-SCE-1/2	12.70 (.500)	4.22 (.166)	0.61 ± 0.08 (.024 ± .003)	20.4 (.803)	29.64 ± 1.14 (1.167 ± .045)	0.68
TMS-SCE-3/4	19.05 (.750)	6.35 (.250)	0.61 ± 0.08 (.024 ± .003)	30.5 (1.20)	42.34 ± 1.14 (1.667 ± .045)	1.20
TMS-SCE-1	25.40 (1.00)	8.46 (.333)	0.64 ± 0.08 (.025 ± .003)	40.4 (1.59)	50.80 ± 1.14 (2.00 ± .045)	1.54
TMS-SCE-1-1/2	38.10 (1.50)	19.05 (.750)	0.51 ± 0.08 (.020 ± .003)	60.3 (2.37)	71.96 ± 1.14 (2.833 ± .045)	2.75
TMS-SCE-2	50.80 (2.00)	25.40 (1.00)	0.64 ± 0.08 (.025 ± .003)	80.0 (3.15)	101.60 ± 1.14 (4.00 ± .045)	4.73
TMS-SCE-2-1/4	57.15 (2.25)	19.05 (.750)	0.76 ± 0.08 (.030 ± .003)	88.9 (3.50)	101.60 ± 1.14 (4.00 ± .045)	4.21

<sup>1</sup> TTMS is available in a more open, less flat profile as TTMS-MP.

<sup>2</sup> Not applicable for TMS-CT and TTMS(MP).



**Table 2. Product Dimensions TMS-SCE-2X and TTMS-2X**

Part Description	“D” Minimum Supplied Inside Diameter mm (inches)	“d” Maximum Recovered Inside Diameter mm (inches)	“w” Wall Thickness After Recovery mm (inches)	Minimum Sleeve Flattened Width mm (inches)	Sleeve Progression <sup>3</sup> mm (inches)	Nominal Weight of single sleeve (~50mm long) grams
TMS-SCE-2X-3/32	2.36 (.093)	1.17 (.046)	0.51 ± 0.08 (.020 ± .003)	4.45 (.175)	12.70 ± 0.89 (.500 ± .035)	0.20
TMS-SCE-2X-1/8	3.18 (.125)	1.58 (.062)	0.51 ± 0.08 (.020 ± .003)	5.84 (.23)	12.70 ± 0.89 (.500 ± .035)	0.28
TMS-SCE-2X-3/16	4.75 (.187)	2.36 (.093)	0.51 ± 0.08 (.020 ± .003)	8.00 (.315)	12.70 ± 0.89 (.500 ± .035)	0.36
TMS-SCE-2X-1/4	6.35 (.250)	3.18 (.125)	0.64 ± 0.08 (.025 ± .003)	10.67 (.420)	16.94 ± 0.89 (.667 ± .035)	0.59
TMS-SCE-2X-3/8	9.53 (.375)	4.75 (.187)	0.64 ± 0.08 (.025 ± .003)	15.49 (.610)	25.40 ± 1.14 (1.00 ± .045)	0.85
TMS-SCE-2X-1/2	12.70 (.500)	6.35 (.250)	0.64 ± 0.08 (.025 ± .003)	20.45 (.810)	29.64 ± 1.14 (1.167 ± .045)	1.15
TMS-SCE-2X-3/4	19.05 (.750)	9.53 (.375)	0.76 ± 0.08 (.030 ± .003)	30.48 (1.20)	42.34 ± 1.14 (1.667 ± .045)	2.06
TMS-SCE-2X-1	25.40 (1.00)	12.7 (.500)	0.889 ± 0.08 (.035 ± .003)	40.39 (1.59)	50.80 ± 1.14 (2.00 ± .045)	2.53

**3 TEST REQUIREMENT**

This specification details the requirements for the TMS-SCE, TMS-CT and TTMS family of products. Table 3 lists the general tests for Identification Products and Table 4 lists the specific tests which reflect the performance of TMS family of products (TMS-SCE, TMS-CT and TTMS(-MP)).

**4 TEST METHODS**

**4.1 Sampling**

Tests shall be carried out on a sample taken at random from a batch. A batch is defined as that quantity of product extruded at any one time.

Testing frequency shall be Production Routine or Qualification.

Production routine tests consisting of visual examination, dimensions, expanded concentricity and longitudinal change, print quality and adherence of marking. These shall be carried out on every batch of sleeving.

Qualification tests shall be carried out to the requirements of the Design Authority.

<sup>3</sup> Not applicable for TTMS-2X product



## 4.2 Preparation of Samples

When required by the test procedure, product shall be printed using printers and ribbons specified by TE Connectivity. The full list can be found in TE document 411-121005 'TE Identification Printer Product Ribbon Matrix'.

Print random characters onto the sleeving to fill the printable area using font type Arial 10, bold. Markers are to be removed from the carrier (ladder format products) or cut/perforated and separated using TE approved printer systems (continuous formats) before testing. Test in both 'as received' and 'fully recovered' form.

The marking shall be examined for legibility in accordance with TE Document 411-121002 Print Contrast Reference Scale. The initial print contrast must be 8 or above.

As required, sleeves or tubing should be recovered by placing them in a forced air oven for 3 minutes at  $200\pm 5^{\circ}\text{C}$  ( $392\pm 7^{\circ}\text{F}$ ). Specimens will be removed from the oven and allowed to cool to  $23\pm 3^{\circ}\text{C}$  ( $73.4\pm 4^{\circ}\text{F}$ ) for at least 4 hours before continuing. Where required by the test method, testing shall be done on continuous tubing. No pre-conditioning period is required prior to testing except where specified.

Unless otherwise specified, all tests shall be made at a temperature of  $23\pm 2^{\circ}\text{C}$  ( $73.4\pm 4^{\circ}\text{F}$ ).

## 4.3 Workmanship

Visually examine three samples for workmanship using normal vision and without magnification. Check for flaws, defects, pinholes, bubbles, seams, cracks or inclusions. The visual examination should be made with the specimen placed inside a laboratory light box with D65 illumination.

Measure the colour of as received sleeves before any printing using a spectrophotometer. Measure and record values for  $L^*a^*b^*$  using the 8mm aperture and D65 illuminance. Color results are recorded for information only.

## 4.4 Print Performance

### 4.4.1 Mark Adherence

Three as supplied and three fully recovered sleeves shall be prepared as detailed in Clause 4.2 and tested in accordance with TE document 109-121012. Samples shall be tested using a Crockmeter fitted with an eraser and 1kg (2.2lb) load using the number of rubs specified in the requirements table.

After the Mark Adherence test, the marking shall be examined for legibility using normal reading vision. Print contrast shall be evaluated in accordance with TE document 411-121002.



#### 4.4.2 Solvent Resistance

Nine as supplied and nine fully recovered sleeves shall be prepared as detailed in Clause 4.2 and tested in accordance with TE document 109-121014. Three sleeves as supplied and three fully recovered sleeves are tested per fluid.

After the test the marking shall be examined for legibility using normal reading vision. Print contrast shall be evaluated in accordance with 411-121002.

#### 4.4.3 Fluid Resistance

The test method shall be as specified in TE document 109-121039. Prepare three as received and three fully recovered markers as detailed in Clause 4.2. Markers shall be completely immersed in each of the fluids for the times and at the temperatures specified in the requirements table. The volume of the fluid shall not be less than 20 times that of the specimen. After immersion, the markers are lightly blotted with tissue paper to remove excess surface fluid and air dried at  $23\pm 2^{\circ}\text{C}$  ( $74\pm 4^{\circ}\text{F}$ ) for  $45\pm 15\text{min}$ . Samples are tested with a Crockmeter fitted with 'Super Twill' cloth and a 1kg (2.2lb) load.

Additional IPA testing is required using three as received and three fully recovered markers as detailed in Clause 4.2. Load the Super Twill' cloth with IPA and test for mark permanence as detailed in TE document 109-121012.

After the print permanence test, marking shall be examined for legibility using normal reading vision. Print contrast shall be evaluated in accordance with 411-121002.

### 4.5 Physical Testing

#### 4.5.1 Dimensions and Longitudinal Change

The test method shall be as specified in TE document 109-121003. Three 50mm (2inch) long marker sleeves shall be tested for inside diameter, and a further three 150mm (6inch) long sleeves taken from a continuous reel shall be tested for Longitudinal Change. For Longitudinal Change, two-gauge marks shall be positioned 100mm (4inch) apart on each sleeve. The markers shall be recovered in a fan assisted oven using the details given in 4.2 and the distance between gauge lengths and inside diameter of each shall be measured, after cooling to room temperature. The longitudinal change shall be expressed as a percentage of the original gauge length. The minimum and maximum recovered wall thickness shall be determined.

#### 4.5.2 Tensile Strength and Ultimate Elongation

The test method shall be as specified in TE document 109-121002. Test five recovered tubular specimens 125mm (5inch) long. An initial jaw separation of 50mm (2inch) with a gauge length of 20mm (.787 inch) and rate of jaw separation of 508mm/minute (19.7"/min) shall be used.

#### 4.5.3 Specific Gravity

Samples of un-printed product shall be tested to the procedure in TE document 109-121015. Three specimens of fully recovered tubing 25mm (1 inch) long should be tested. Test specimens should be prepared in a way to prevent trapping air.



#### 4.5.4 Split testing

The test method shall be as specified in TE document 109-121031. Ten perforated or scored marker sleeves should be tested. Samples should be recovered, onto an ambient temperature mandrel for five minutes in the fan assisted oven at  $200\pm 5^{\circ}\text{C}$  ( $392\pm 7^{\circ}\text{F}$ ). Samples should be examined for splitting after cooling to  $23\pm 2^{\circ}\text{C}$  ( $73.4\pm 4^{\circ}\text{F}$ ) as specified in section 4.3.

#### 4.5.5 2% Secant Modulus

The test method shall be as specified in TE document 109-121004. Five specimens 180mm (7.09 inch) long of expanded tubing should be tested.

### 4.6 Thermal Testing

#### 4.6.1 Heat Shock

The test method shall be as specified in TE document 109-121007. Six sleeves shall be prepared as detailed in section 4.2. Specimens shall be conditioned for 4 hours at  $250\pm 3^{\circ}\text{C}$  ( $480\pm 5^{\circ}\text{F}$ ) in an air circulating oven. Remove the markers and leave to cool to room temperature for a minimum of 2 hours at  $23\pm 2^{\circ}\text{C}$  ( $73\pm 4^{\circ}\text{F}$ ).

After conditioning, three samples shall be tested for Mark Adherence in accordance with section 4.4.1 and three shall be subjected to the bend test detailed in 109-121007.

The marking shall be examined for legibility using normal reading vision. Print contrast shall be evaluated in accordance with 411-121002.

#### 4.6.2 Heat Ageing

The test method shall be as specified in TE document 109-121008. Six sleeves shall be prepared as detailed in section 4.2. Five samples shall also be prepared for Ultimate Elongation testing as given in section 4.5.2. Specimens shall be conditioned for 168 hours at  $175\pm 2^{\circ}\text{C}$  ( $347\pm 5^{\circ}\text{F}$ ) in an air circulating oven. Markers shall be removed and allowed to cool to room temperature for a minimum of 4 hours at  $23\pm 2^{\circ}\text{C}$  ( $73\pm 4^{\circ}\text{F}$ ).

After conditioning three samples shall be subjected to the bend test as given in 109-121008 and three samples shall be tested for Mark Adherence, in accordance with section 4.4.1.

The marking shall be examined for legibility using normal reading vision. Print contrast shall be evaluated in accordance with 411-121002. The remaining three samples shall be tested for resistance to bending. Mandrel diameter for 1/4inch (6.4mm) size tubing is 9.5mm (.374inch).



#### 4.6.3 Thermal Cycling

The test method shall be as specified in TE document 109-121046. Six as received samples should be prepared for testing as detailed in section 4.2. Specimens shall be conditioned for 4 cycles of 1 hour at  $-55\pm 2^{\circ}\text{C}$  ( $-67\pm 4^{\circ}\text{F}$ ) and then 1 hour at  $135\pm 2^{\circ}\text{C}$  ( $275\pm 5^{\circ}\text{F}$ ) in an air circulating oven. After each heating and cooling period, the samples shall be stored at  $23\pm 2^{\circ}\text{C}$  ( $73\pm 4^{\circ}\text{F}$ ) for 16 hours. After cycling remove the markers and leave to cool to room temperature for a minimum of 2 hours at  $23\pm 2^{\circ}\text{C}$  ( $73\pm 4^{\circ}\text{F}$ ).

Three samples shall be tested for Mark Adherence in accordance with section 4.4.1. The marking shall be examined for legibility using normal reading vision. Print contrast shall be evaluated in accordance with 411-121002.

The three remaining samples shall be tested for resistance to bending. Mandrel diameter for 1/4inch (6.4mm) size tubing is 9.5mm (.374inch).

#### 4.6.4 Low Temperature Flexibility

The test method shall be as specified in TE document 109-121006. Six as received and six fully recovered sleeves shall be prepared as detailed in section 4.2. Specimens and the test mandrel shall be conditioned for 4 hours at  $-55\pm 2^{\circ}\text{C}$  ( $-67\pm 4^{\circ}\text{F}$ ) in a cold chamber. After conditioning, and while still at the temperature of  $-55\pm 2^{\circ}\text{C}$  ( $-67\pm 4^{\circ}\text{F}$ ), half of the samples shall be immediately tested for resistance to bending. Mandrel diameter for 1/4inch (6.4mm) size tubing is 9.5mm (.374inch).

Three of each of the remaining markers shall be removed from the cold chamber and allowed to return to room temperature for a minimum of 2 hours at  $23\pm 2^{\circ}\text{C}$ . Samples shall be tested for Mark Adherence in accordance with section 4.4.1. The marking shall be examined for legibility using normal reading vision. Print contrast shall be evaluated in accordance with 411-121002.

### 4.7 Environmental Testing

#### 4.7.1 Copper Mirror Corrosion

The test method shall be as specified in TE document 109-121009. Three glass test tubes should be used. Prepare one control tube with copper mirror only, and two tubes with mirrors and printed product. Prepare samples using printed recovered specimens, at least  $150\text{mm}^2$  ( $.233\text{inches}^2$ ) surface area of product shall be in each tube. After the test, mirrors should be assessed for corrosion.

#### 4.7.2 Copper Contact Corrosion

The test method shall be as specified in TE document 109-121010. Three specimens 150mm (6inches) long shall be recovered on to a clean copper wire and stored for 16hours at  $175\pm 2^{\circ}\text{C}$  ( $347\pm 4^{\circ}\text{F}$ ). After the samples have cooled to room temperature the sleeve is removed from the copper wire and the wire is inspected for signs of corrosion.



#### 4.7.3 Water Absorption

The test method shall be as specified in TE document 109-121016. Three 25mm (1inch) long helical samples should be cut from recovered printed tubing specimens. Samples should be weighed after drying in the oven and after immersion in water. The mean average of three samples should be stated.

#### 4.7.4 UV Resistance

The test shall be carried out using a UV-O-meter chamber in accordance with ASTM G154. Test for 1000 hours at 1.35 W/m<sup>2</sup>/nm irradiance.

Prepare three recovered and three as supplied for print adherence testing with an additional three recovered and three as supplied installed on mandrel for bend tests.

Condition two sets of markers prepared as specified in section 4.2 to the following regimes:

- i) UVA type fluorescent bulbs, consisting of a repeating cycle of 8 hours exposure at 60±2°C (140±4°F) followed by 4 hours of condensation at 50±2°C (122±4°F).
- ii) UVB type fluorescent bulbs, consisting of a repeating cycle of 8 hours exposure at 60±2°C (140±4°F) followed by 4 hours of condensation at 50±2°C (122±4°F).

After conditioning test half of the sleeves for flexibility using a 90° mandrel bend test. Mandrel diameter for TMS-SCE 6.4 size tubing is 9.5mm (.374inch). Samples shall be visually examined for cracking or splitting.

The remainder of the samples shall be measured for colour change using a spectrophotometer. Measure an area of the sleeve which has not been printed.

Test Mark Adherence in accordance with section 4.4.1. The marking shall be examined for legibility using normal reading vision. Print contrast shall be evaluated in accordance with 411-121002.

#### 4.7.5 Color Stability

Three recovered samples are stored for 24hour at 175±2°C (347±4°F). The L\*a\*b\* color coordinates are measured before and after the exposure period. There should be no significant change in color.

#### 4.7.6 Fluid Resistance at Ambient Temperature

Prepare five samples for Tensile Strength testing as given in section 4.5.2 and a set of five samples for dielectric strength as given in section 4.8.1. A set of samples is required for each test fluid given in the requirements table.

Tubes shall be completely immersed in each of the fluids for the times at ambient temperature. The volume of the fluid shall not be less than 20 times that of the specimen. After immersion, the markers are lightly blotted with tissue paper to remove excess surface fluid and air dried at 23±2°C for 45±15min.

After conditioning samples will be tested for Tensile Strength (section 4.5.2) and Dielectric strength (section 4.8.1).



#### **4.7.7 Fungus Resistance**

Samples shall be prepared for Tensile strength and Ultimate Elongation (section 4.5.2), Dielectric strength (4.8.1) and Mark Adherence (section 4.4.1). The samples shall be exposed in accordance with ISO 846 Method B, 56day exposure.

After exposure the samples shall be tested to the appropriate test given in the sections referenced.

### **4.8 Electrical Testing**

#### **4.8.1 Dielectric Strength**

The test method shall be as specified in TE document 109-121005. Five printed 150mm (6inches) long specimens to be recovered onto clean steel mandrels (ensuring a tight fit) 24 hours before testing. A 25mm (1inch) wide aluminium self-adhesive foil electrode to be installed in the centre of each of the recovered and cooled down samples. Average dielectric strength of five samples to be recorded as the result.

#### **4.8.2 Volume Resistivity**

The test method shall be as specified in TE document 109-121017. Three 200 to 250mm (8 to 10inches) long printed specimens are to be recovered onto clean 300mm long, steel mandrels (no larger in diameter than 15% of the fully recovered diameter of the tested tubing). Each sample should have a 150mm (6inches) long silver paint electrode painted a minimum 4 hours before testing. Average volume resistivity value should be recorded as the result.

#### **4.8.3 Restricted Shrinkage and Voltage Withstand**

Three samples shall be prepared as detailed in AS23053. Each sample shall be recovered on to the restricted shrinkage mandrels using a temperature of  $175\pm 5^{\circ}\text{C}$  ( $347\pm 7^{\circ}\text{F}$ ) for 30minutes.

After conditioning the samples shall be investigated for splitting and shall be tested for Voltage withstand at 2000V for 1minute in accordance with ASTM D149.

### **4.9 Fire Safety**

#### **4.9.1 Fire Propagation, ASTM D 2671 Procedure B**

Five printed samples shall be prepared and tested in accordance with TE document 109-121053. 460mm (18.1inches) long samples should be installed onto 530mm (20.9inches) long mandrels. Each sample should have a paper flag indicator 250mm (10inches) above the flame impingement point. The flame should be applied to the sample at a  $70^{\circ}$  angle. The flame should be applied five times, each application is 15s on and 15s off.

The duration of burning and percentage of the burnt area shall be recorded.

Five printed samples of TMS-SCE-2X shall also be tested to ASTM D2671 procedure C.



#### **4.9.2 EN45545-2 Flammability Hazard Level, Oxygen Index, BS EN ISO 4589-2**

The test method shall be as specified in TE document 109-121054. Tests shall be carried out on 3mm (1/8inch) thick plaques of the material from which the sleeving is fabricated. The plaque should be irradiation cross-linked to the same degree as the sleeving. Test piece dimensions shall be  $6.5\pm 0.5\text{mm} \times 80\pm 1\text{mm}$  (1/4 x 3.15inches) cut from the plaques. Samples shall be conditioned for at least 24hrs at  $23\pm 2^\circ\text{C}$  ( $73.4\pm 3^\circ\text{F}$ ) prior to testing. A new test piece shall be used for each determination.

#### **4.9.3 Surface Flammability, Flame Spread Index, Is, ASTM E162**

This test is performed in accordance with ASTM E162, with the following modification: Instead of testing a moulded plaque, 25.4mm (1inch) continuous tubing printed with two lines of text is used.

To arrange the samples to form the specified exposed area, 13mm (.512inch) wide cement board fingers are cut from a single board. Six 75mm (3inch) lengths are cut from the tube, which is then recovered over the cut cement board fingers. The cement board fingers are butted together to form a single sheet. Five single sheets are placed side by side vertically for each test to create the required test specimens. Samples condition for at least 24 hours at  $23\pm 2^\circ\text{C}$  ( $73.4\pm 3^\circ\text{F}$ ) before fire testing.

#### **4.9.4 Smoke Optical Density, Ds ASTM E662**

This test is performed in accordance with ASTM E662, with the following modification: Instead of testing a moulded plaque, 25.4mm (1inch) continuous tubing printed with two lines of text is used.

To arrange the samples to form the specified exposed area, 13mm (.512inch) wide cement board fingers are cut from a single board. Six 75mm (3inch) lengths are cut from the tube, which is then recovered over the cut cement board fingers. The cement board fingers are butted together to form a single sheet. Samples condition for at least 24 hours at  $23\pm 2^\circ\text{C}$  ( $73.4\pm 3^\circ\text{F}$ ) before fire testing. Testing is carried out using an NBS smoke chamber with a  $25\text{kW}/\text{m}^2$  radiant heat. Tests are carried out with and without a pilot flame.

#### **4.9.5 Heat Release, ASTM E1354**

This test is performed in accordance with ASTM E1354, with the following modification: Instead of testing moulded plaques, 25.4mm (1inch) continuous tubing which has been printed with two lines of text is used.

To arrange the samples to form the specified exposed area, 13mm (.512inch) wide cement board fingers are cut from a single board. Six 75mm (3inch) lengths are cut from the tube, which is then recovered over the fingers. The cement board fingers are butted together to form a single sheet. Samples condition for at least 24 hours at  $23^\circ\text{C}$  ( $73 \pm 7^\circ\text{F}$ ) before fire testing.

Samples are tested using a  $50\text{kW}/\text{m}^2$  heat flux. Average Heat Release Rate, Maximum (peak) heat release rate and Average Specific Extinction Area at 3 minutes is measured.



#### 4.9.6 Toxic Gas Generation

This test is performed in accordance with BSS 7239, with the following modification: Instead of testing a moulded plaque, 25.4mm (1inch) continuous tubing printed with two lines of text is used to represent end use condition.

To arrange the samples to form the specified exposed area, 13mm (.512inch) wide cement board fingers are cut from a single board. Six 75mm lengths are cut from the tube, which is then recovered over the cut cement board fingers. The cement board fingers are butted together to form a single sheet. Samples are conditioned for at least 24 hours at 23°C before fire testing.

Gases are extracted and analysed using the techniques described in BSS 7239.

### 5 RELATED DOCUMENTS

#### 5.1 International Standard

ASTM D149: 2013	Standard Test Method for Dielectric Breakdown Voltage and Dielectric Strength of Solid Electrical Insulating Materials at Commercial Power Frequencies
ASTM D2671: 1999	Standard Test Methods for Heat-Shrinkable Tubing for Electrical Use
ASTM G-154-12a	Standard plastics for operating light and water exposure apparatus (fluorescent UV condensation type) for exposure of non-metallic materials.
AS230535	Insulating Sleeving, Electrical, Heat Shrinkable, General Specification for Marking of Electrical Insulation Materials.
AS23053/5A	Insulating Sleeving, Electrical, Heat Shrinkable, Polyolefin, Flexible Cross-linked.
BS 4G 198-3: 1999	Sleeves and moulded components for aircraft electric cables and equipment wires. Specification for heat shrinkable sleeving for binding, insulation and identification
BS 6853:1999	Code of Practice for Fire Precautions in The Design and Construction of Passenger Carrying Trains
BS EN ISO 4589-2: 1996	Plastics – Determination of burning behaviour by oxygen index - Part 2: Ambient temperature test
BS EN 45545-2: 2013+A1:2015	Railway applications- Fire protection on railway vehicles
ISO 846: 1997	Plastics – Evaluation of the action of microorganisms
MIL 202G Method 215K	Resistance to solvents
SAE AS5942: 2014	Marking of Electrical Insulating Materials



## 5.2 TE Connectivity Documents

TE Reference	Title	Complies with
411-121002	TE Connectivity Print contrast reference scale	---
411-121005	TE Identification Printer Product Ribbon Matrix	---
109-121002	Tensile strength and Ultimate elongation	ASTM D2671
109-121003	Dimensions	---
109-121004	Secant modulus at 2% elongation	ASTM D2671
109-121005	Dielectric strength	ASTM D2671 (ASTM D149)
109-121006	Low temperature flexibility	IEC 60684-2
109-121007	Heat shock	AS23053, ASTM D2671
109-121008	Heat ageing	AS23053, ASTM D2671
109-121009	Copper mirror corrosion	AS23053
109-121010	Copper contact corrosion	AS23053
109-121012	Mark adherence	AS5942
109-121014	Resistance to solvents	MIL 202, Method 215
109-121015	Specific gravity	ASTM D792
109-121016	Water absorption	ASTM D570
109-121017	Volume resistivity	ASTM D2671, ASTM D257
109-121031	Split resistance	---
109-121039	Fluid Immersion Testing at room temperature.	---
109-121046	Thermal shock and cycling	---
109-121053	Flammability testing in accordance with ASTM D 2671 procedure B & C	ASTM D2671, procedure B
109-121054	Limited Oxygen Index	BS EN ISO 4589-2:1999



## 6 STORAGE CONDITIONS

Product should be stored in its original packaging, with any plastic covers which were included during shipping. Store out of direct sunlight in a clean, dry, dust free, environment. Product should not be stored outside of the designed storage temperature, which is -10°C (14°F) to 35°C (95°F), and 50±30% RH.

## 7 PACKAGING

Packaging shall be in accordance with good commercial practice. Each package shall bear an identification label showing material quantity, description, size, color and batch number. Additional information shall be supplied as specified in the contract or order

## 8 SHELF LIFE<sup>4</sup>

When stored as prescribed above, the shelf life of this heat shrink product is 144 months from date of manufacture.

---

<sup>4</sup> Shelf Life is a guideline based on 30 years' experience. TE Connectivity cannot provide any test data to validate this statement.



**9 TABLE 3: GENERAL REQUIREMENTS FOR IDENTIFICATION PRODUCTS**

PROPERTY	TEST METHOD	UNITS	REQUIREMENTS	RW-2511 SECTION
<b>PRINT PERFORMANCE</b>				
<b>Print Quality</b>			Legible, minimum print contrast C8	4.2.
<b>Mark Adherence</b>	109-121012 50 rubs, 1kg load, eraser	---	Legible, minimum print contrast C3	4.4.1.
<b>Solvent Resistance</b>	109-121014	---	Legible, minimum print contrast C3	4.4.2.
Solution A Solution B Solution C	30 strokes, tooth brush			
<b>Fluid Resistance, Mark Permanence</b>	109-121039	---	Legible, minimum print contrast C3	4.4.3.
Reference oil IRM 902 MIL-PRF-23699 lubricating oil Skydrol LD-4 hydraulic fluid MIL-H-83282 hydraulic fluid JP8 jet fuel Diesel fuel Kilfrost DF Plus Tap water 5% Sodium chloride solution 1% Teepol detergent	24 hours immersion at 23±2°C (73.4±3°F), followed by 20 rubs with 1kg load			
Isopropyl alcohol (IPA)	109-121012 20 cycles, soaked "Super Twill" cloth. 1kg load	---	Legible, minimum print contrast C3	4.4.3.



PROPERTY	TEST METHOD	UNITS	REQUIREMENTS	RW-2511 SECTION
<b>PHYSICAL TESTING</b>				
<b>Workmanship</b>	Laboratory light box with D65 lighting, using normal or corrected vision at 355mm (14inch).	---	In accordance with section 4.3	4.3.
<b>Dimensions</b>	109-121003	mm	Tables 1 to 4 above	4.5.1.
<b>Longitudinal Change</b>	109-121003	%	Shrink ratio 3:1 0 to -20 Shrink ratio 2:1 tube $\pm 5$	4.5.1.
<b>Tensile Strength</b>	109-121002	MPa (psi)	10.3 (1493) minimum	4.5.2.
<b>Ultimate Elongation</b>	109-121002	%	200 minimum	4.5.2.
<b>Specific Gravity</b>	109-121015	---	1.30 $\pm$ 0.05	4.5.3.
<b>Split testing</b>	109-121031	%	100 pass	4.5.4.
<b>THERMAL TESTING</b>				
<b>Heat Shock</b> 4 hours at 250°C (482°F) Mandrel Bend Mark Adherence	109-121007  109-121012, 20 rubs 1kg load, eraser	---	No damage to the marker and print  Legible, minimum print contrast C3	4.6.1.  4.4.1
<b>Heat Ageing</b> 168hrs at 175°C (347°F) Mandrel Bend Mark Adherence	109-121008  109-121012, 20 rubs 1kg load, eraser	---	No damage to the marker and print  Legible, minimum print contrast C3	4.6.2.  4.4.1
<b>Thermal cycling</b> 4 cycles of: 1 hour at -55°C (-67°F) then 1 hour at 135°C (275°F) and 16 hours 23°C (73.4°F), followed by:	109-121046  90° bend around a 9.5mm (.374inch) mandrel	---	No damage to the marker and print	4.6.3.
Mark Adherence	109-121012 20 rubs, 1kg load, eraser	---	Legible, minimum print contrast C3	4.4.1
<b>Low Temperature flexibility</b> 4 hours at -55°C (-67°F), followed by:	109-121006  90° bend around a 9.5mm (.374inch) mandrel	---	No damage to the marker and print	4.6.4.
Mark Adherence	109-121012 20 rubs, 1kg load, eraser	---	Legible, minimum print contrast C3	4.4.1



PROPERTY	TEST METHOD	UNITS	REQUIREMENTS	RW-2511 SECTION
<b>ENVIRONMENTAL TESTING</b>				
<b>Copper Mirror Corrosion</b> 16hr at 175°C (347°F)	109-121009	%	Damaged area of copper mirror, 8 maximum	4.7.1.
<b>Water Absorption</b>	109-121016	%	0.5 maximum	4.7.3.
<b>UV Resistance</b> followed by:  Mandrel Bend  Mark Adherence	ASTM G154 UVA and UVB (8 hours dry/4 hours wet cycle)  90° bend around a mandrel (10 x thickness)  109-121012 20 rubs, 1kg load, eraser		1000 hours at each wavelength.  No damage to the marker and print  Legible, minimum print contrast 3	4.7.4.   4.4.1
<b>ELECTRICAL</b>				
<b>Dielectric Strength</b>	109-121005	kV/m (V/mil)	20 (500) minimum	4.8.1.
<b>Volume Resistivity</b>	109-121017	Ohm cm	10 <sup>14</sup> minimum	4.8.2.
<b>FIRE SAFETY</b>				
<b>Fire Propagation,</b> ASTM D2671 Procedure B	109-121053 ASTM D2671 procedure B	---	Burn time shall not exceed one minute, and not more than 25% of indicator flag shall be burned or charred. No dripping or flowing. No burning of cotton.	4.9.1.
<b>EN45545-2 Flammability</b> <b>Hazard rating:</b>  BS EN ISO 4589-2 Oxygen Index (OI),	BS EN ISO 4589-2 109-121054	%	28 minimum	4.9.2.
<b>Surface Flame</b>	ASTM E 162	---	35 maximum	4.9.3.
<b>Specific Optical Smoke Density, Ds</b>  1.5 minutes 4 minutes	ASTM E 662 25kW/m <sup>2</sup> radiant heat source.  Flaming mode and non-flaming mode.		100 maximum 200 maximum	4.9.4.



PROPERTY	TEST METHOD	UNITS	REQUIREMENTS	RW-2511 SECTION
<b>FIRE SAFETY continued.</b>				
<b>Heat Release<sup>5</sup></b> Average Heat Release Rate (180 s)	ASTM E1354 50kWm <sup>2</sup> applied heat flux with retainer frame	kW/m <sup>2</sup>	300 maximum	4.9.5.
<b>Toxic Gas Generation BSS 7239</b> Carbon Monoxide (CO) Nitrogen Oxides (NO <sub>2</sub> ) Sulphur Dioxide (SO <sub>2</sub> ) Hydrogen Chloride (HCl) Hydrogen Fluoride (HF) Hydrogen Bromide (HBr) Hydrogen Cyanide (HCN)	Gas extracted during ASTM E662 test. 25kW/m <sup>2</sup> radiant heat source.  Flaming mode and non-flaming mode assessed, worst case reported.	ppm	Maxima:  3500 100 100 500 200 100 150	4.9.6.

**10 TABLE 4: SPECIFIC REQUIREMENTS FOR TMS FAMILY HEAT SHRINK SLEEVING**

PROPERTY	TEST METHOD	UNITS	REQUIREMENTS	RW-2511 SECTION
<b>PHYSICAL</b>				
<b>Concentricity</b> (Expanded tube)	109-121003	%	50% minimum (3X) 70% minimum (2X)	4.5.1.
2% Secant Modulus	109-121004	MPa (psi)	172.4 (25,000) maximum	4.5.5.
<b>Color</b>		---		4.7.5.
<b>Color Stability</b> 24hr at 175°C (347°F)	AS23053	---	No significant visual change, recognizable as a color. Measure and record only.	4.7.5.
<b>THERMAL TESTING</b>				
<b>Heat Ageing, Mechanical Properties</b> 168 hours at 175°C (347°F) followed by:	109-121008			4.6.2.
Ultimate Elongation	109-121002	%	100 minimum	4.5.2

<sup>5</sup> There is currently no requirement for Heat Release testing. TE have incorporated proposed changes to existing FRA 49 CFR Ch. II, Part 238, App. B as recommended by the National Association of State Fire Marshals



Table 4 continued				
PROPERTY	TEST METHOD	UNITS	REQUIREMENTS	RW-2511 SECTION
<b>ELECTRICAL</b>				
<b>Restricted Shrinkage</b> 30 min at 175°C (347°F) Visual examination Voltage Withstand	AS23053			4.8.3.
	ASTM D149	--- V	No Cracks. 2000 Vac for 1 minute	
<b>CHEMICAL</b>				
<b>Copper Contact</b>	AS23053	---	No pitting or blackening of the copper	4.8.2.
<b>ENVIRONMENTAL PROPERTIES</b>				
<b>Fluid Resistance at Ambient Temperature, Physical Properties &amp; Electrical Tests</b>	109-121039			4.7.6.
	109-121002 109-121005	MPa kV/mm (V/mil)	6.9 (1000) minimum 15.8 (400) minimum	4.5.2 4.8.1
MIL-PRF-23699 lubricating oil				
MIL-H-5606 Hydraulic Fluid				
JP8 Jet Fuel				
Kilfrost DF Plus				
MIL-L-7808				
5% Sodium Chloride Solution				
<b>Fungus Resistance</b>	ISO 846 Method B			4.7.7
Tensile Strength	109-121002	MPa (psi)	10.3 (1500)	4.5.2
Ultimate Elongation		%	200 minimum	
Dielectric Strength	109-121005	kV/mm	19.7 minimum	4.8.1
Print Adherence (20 rubs)	109-121012	---	Print legible, minimum contrast C3	4.4.1
<b>FLAMMABILITY</b>				
<b>Flammability</b> Procedure C  TMS-SCE-2X product only	109-121053 ASTM D2671	s %	Burn time shall not exceed one minute, and not more than 25% of indicator flag shall be burned or charred. No dripping or flowing. No burning of cotton	4.9.1



**11 TEST FLUIDS**

Fluid	Description
<b>Standard Fluids</b>	
IRM902	Reference Oil (ASTM oil NO. 2 replacement)
MIL-PRF-23699	Synthetic lubricating oil STD class (NATO Code 0-156). Has replaced MIL-L-7808 oil at temperatures above 25°C.
Skydrol LD-4	Widely used aviation phosphate ester based hydraulic fluid.
MIL-H-83282	The principal hydraulic fluid used in military aircraft. It replaces MIL-H-5606.
MIL-T-83133 (JP-8)	Kerosene based jet fuel, replacement for JP-4. NATO code is F-34. It's specified by MIL-DTL-83133 and British Defence Standard 91-87.
Diesel Fuel (BS EN 590:2009+A1)	General fuel used in transportation
Kilfrost DF Plus (SAE-AMS-1424)	Aircraft de-icing fluid
Tap Water	Universal solvent
5% Sodium chloride solution	Sodium chloride is a universal compound used in many chemicals and de-icing fluids
Detergent (1% Teepol)	Commonly used industrial detergent
IPA - Isopropyl alcohol	Widely used as a solvent and cleaner
<b>Specific test fluids</b>	
MIL-H-5606	Military grade hydraulic fluid
MIL-PRF-7808	Turbine oil

## Looking for pricing, stock, or lifecycle information?

Click below to explore more details on WIN SOURCE:

- ⊖ [View TMS-SCE-3/16-2.0-9](#) on WIN SOURCE
- ⊖ [TE Connectivity](#) Information

## Optimize Your Supply Chain with WIN SOURCE Solutions

- ✓ Global Sourcing Solution
- ✓ Obsolete Management
- ✓ Cost Control Management
- ✓ Shortage Management
- ✓ Alternative Solution
- ✓ Excess Inventory Management