

Digi-Key

Issue No. : 151EXB013016

Date of Issue : May 10.2013

Classification :  New  Changed

## PRODUCT SPECIFICATION FOR APPROVAL

Product Description : Chip Resistor Array

Product Part Number : EXB24V\*\*\*\*X  
EXB24V\*\*\*\*FX

Country of Origin : JAPAN, CHINA

Applications : Standard electronic equipment

\*If you approve this specification, please fill in and sign the below and return 1 copy to us.

Approval No	:	
Approval Date	:	
Executed by	:	
		_____
		(signature)
Title	:	
Dept.	:	

### Circuit Components Business Division

**Automotive & Industrial Systems Company**  
**Panasonic Corporation**

401 Sadamasa-cho,  
Fukui City 910-8502 Japan  
Phone : +81-776-56-8034

Prepared by : Morita factory Engineering group

Contact Person : *H. Yabukoshi*

Signature

Name(Print) : H.Yabukoshi

Title :

Authorized by : *Y. Morimoto*

Signature

Name(Print) : Y.Morimoto

Title : Manager of Engineering

# Panasonic

Subject Chip Resistor Array PRODUCT SPECIFICATION FOR INFORMATION	Spec. No. 151-EXB-24V01VE
Part No. <b>EXB24V</b>	8-1

### 1. Dimension

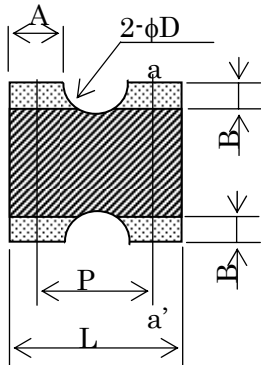

(1)Substrate	(2)Protective coating	(3)Resistive element
Alumina	Resin	Metal glaze
(4)Termination (Inner)	(5)Termination (Between)	(6) Termination (Outer)
Ag or Ag/Pd Side:Resin+Metal	Ni Plating	Sn Plating

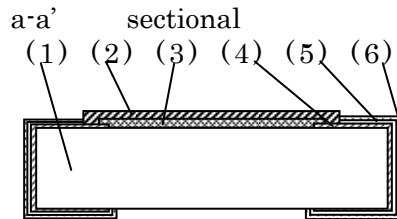
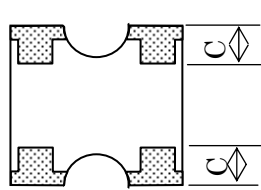

	L	W	T	A	B
Dimension(mm)	1.00±0.10	1.00±0.10	0.35±0.10	0.40±0.10	0.18±0.10

	D	P	C
Dimension(mm)	(0.30)	(0.65)	0.25±0.10

( ) : Reference

### 2. Power derating curve

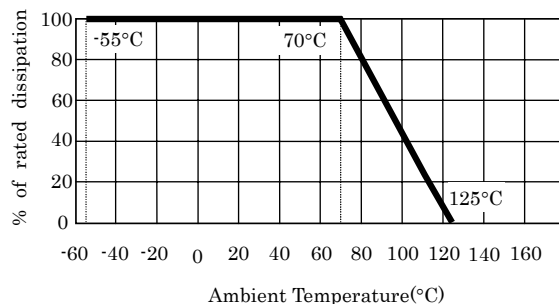

Category temperature range  
-55°C to +125°C

Fig. 1

### 3. Ratings

Item	Rated value (Explanation)
Rated Dissipation	0.063 W / element When used at ambient temperature over 70 °C, the rated dissipation should be reduced as shown in Fig.1
Rated voltage & Rated Continuous Working Voltage (RCWV)	The rated voltage of each resistor should be calculated from the equation below, and when the rated voltage exceeds the limiting element voltage, the limiting element voltage should be the maximum working voltage. $E = \sqrt{P \times R}$ Limiting element voltage : 50 V E: Rated voltage(V), P: Rated dissipation(W), R: Rated resistance(Ω) Chip jumper : Rated current 1 A

Subject Chip Resistor Array PRODUCT SPECIFICATION FOR INFORMATION	Spec. No. 151-EXB-24V01VE
Part No. <b>EXB24V</b>	8-2

Item	Rated value (Explanation)			
Resistance Tolerance	Sign	Resistance Tolerance		
	F	±1%		
	J	±5%		
	0	Chip Jumper		
Resistance range	Sign	Resistance range	Series	Digit
	*F	10 Ω to 1.0 MΩ	E-24,E-96	4 digits
	J	10 Ω to 1.0 MΩ	E-24	3 digits
	0	Less than 50 mΩ	-	
* F: Part number is only by 4 digits				

#### 4. Explanation of part number

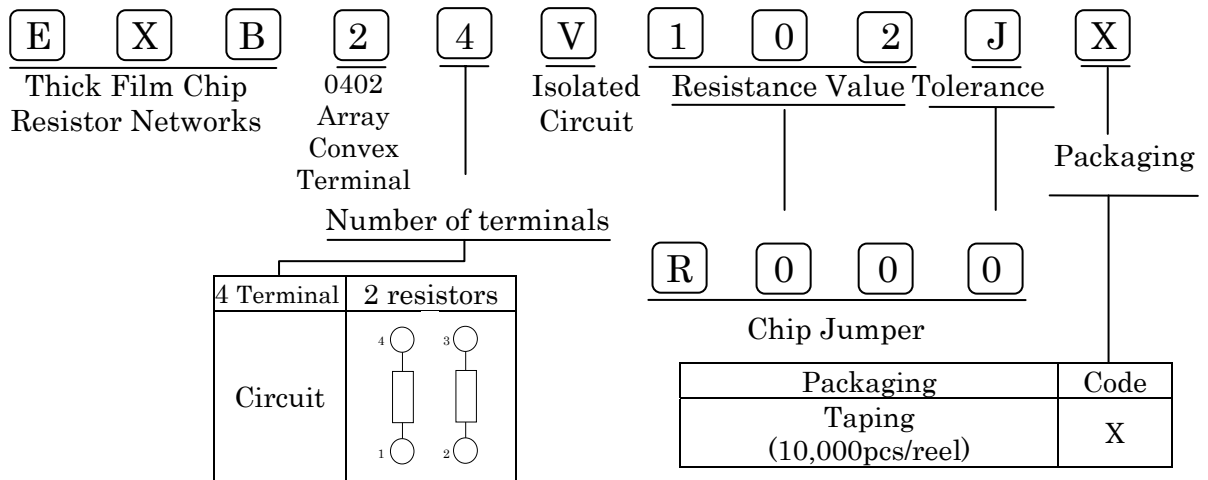

#### 5. Appearance & Construction

Item	Explanation
Appearance & Construction	1.The resistive element should be covered with protective coating that do not fade easily. The surface of coating should avoid unevenness, flaw, pinhole and discoloration. 2.The electrode should be printed uniformly, as shown in the dimensions. The plating should not fade easily, and should avoid unevenness, flaw, pinhole, projection and discoloration. 3.The electrode should be connected electrically, mechanically to resistive element. 4.Substrate should not have chipping, flaw, flash and crack.

As far as there shall not designation especially, the following tests and measurement shall be operated under the following conditions.

Ambient temperature : 15 °C to 35 °C

Relative humidity : 25 % to 75 %

Atmospheric pressure : 86k Pa to 106k Pa

# Jumper shall be guaranteed in measuring put on upper interelectrode.

Subject Chip Resistor Array PRODUCT SPECIFICATION FOR INFORMATION	Spec. No. 151-EXB-24V01VE
Part No. <b>EXB24V</b>	8-3

## 6. Performance Specification

Item	Specification		Test methods
	Resistor	Jumper	
DC resistance	DC resistance value shall be within the specified tolerance		Measuring voltage: refer to JIS-C5201-1 At 20 °C, 65 % Relative humidity
Temperature coefficient	Resistance	TCR	Natural resistance change per temperature degree centigrade. $TCR = \frac{R_2 - R_1}{R_1 \times (t_2 - t_1)}$ R <sub>1</sub> : Resistance value at reference temperature(t <sub>1</sub> ) R <sub>2</sub> : Resistance value at test temperature(t <sub>2</sub> ) t <sub>2</sub> - t <sub>1</sub> = 100 °C, t <sub>1</sub> = 25 °C
	10Ω to 1MΩ	±200×10 <sup>-6</sup> / °C	
	Chip jumper : Less than 50 mΩ		
Overload	±(2 %+0.1 Ω)	Less than 50 mΩ	Resistors shall be applied 2.5 times the rated voltage for 5 seconds. However, the upper limit of the voltage in the test shall be 100V. In addition, the current applied to the jumper in the test shall be 2A.
Dielectric Withstanding	No evidence of flashover, mechanical damage, arcing or insulation breakdown.		AC 100V between substrate and termination for 1 minute.
Insulation resistance	Min. 1,000 MΩ		Insulation resistance between substrate and termination shall be measured at DC 100V.

## 7. Mechanical characteristic

Item	Specification		Test methods
	Resistor	Jumper	
Adhesion	No mechanical damage		Load of 9.8N shall be applied to a side of resistor for 10s, which is placed on printing board Printing board: Glass epoxy (t = 1.0 mm)
	±(1 %+0.05 Ω)	Less than 50 mΩ	
Bend strength of the face plating	No mechanical damage		Substrate: Glass epoxy(t = 1.0 mm) Span: 90 mm Bending distance: 3 mm (10 seconds)
	±(1 %+0.05 Ω)	Less than 50 mΩ	
Solderability	Termination should be covered uniformly with solder. (min. 95 % coverage)		Resistors shall be dipped in the melted solder bath at 235 °C ± 5 °C for 2 s ± 0.5 s. Flux shall be removed from the surface of termination with clean organic solvent.
Resistance to soldering heat	±(1 %+0.05 Ω)	Less than 50 mΩ	Resistors shall be dipped in the melted solder bath at 270 °C ± 5 °C for 10s ± 1s.
Vibration	±(1 %+0.05 Ω)	Less than 50 mΩ	Resistors shall be subjected to a single vibration having as double amplitude of 1.5 mm for 2 hours in each three mutually perpendicular directions for total 6 hours. The vibration frequency shall be varied uniformly 10 Hz to 55 Hz and return to 10 Hz traversing for 1 minute.

Subject	Chip Resistor Array PRODUCT SPECIFICATION FOR INFORMATION	Spec. No.	151-EXB-24V01VE
Part No.	<b>EXB24V</b>		8-4

Item	Specification		Test methods
	Resistor	Jumper	
Solvent resistance	Without distinct deformation in appearance		Solvent solution: Isopropyl alcohol (1) Dipping 10 hours $\pm$ 1 hour, dry in room condition for 30 min $\pm$ 10 min. (2) Ultrasonic wave washing: 5 min $\pm$ 1 min (0.3 W/cm <sup>2</sup> , 28 kHz) Dry in room condition for 30 min $\pm$ 10 min.
	$\pm(0.5 \%+0.05 \Omega)$	Less than 50 m $\Omega$	

### 8. Environmental Test

Item	Specification		Test methods
	Resistor	Jumper	
Low temperature exposure	$\pm(1 \%+0.05 \Omega)$	Less than 50 m $\Omega$	Resistors shall be exposed at $-55^{\circ}\text{C} \pm 3^{\circ}\text{C}$ for 1000 hours $\begin{smallmatrix} +48 \\ 0 \end{smallmatrix}$ hours
Endurance at upper category temperature	$\pm(1 \%+0.05 \Omega)$	Less than 50 m $\Omega$	Resistors shall be exposed at $+125^{\circ}\text{C} \pm 3^{\circ}\text{C}$ for 1000 hours $\begin{smallmatrix} +48 \\ 0 \end{smallmatrix}$ hours.
Temperature cycling	$\pm(1 \%+0.05 \Omega)$	Less than 50 m $\Omega$	$-55^{\circ}\text{C} \pm 3^{\circ}\text{C}$ , 30 minutes $\uparrow\downarrow$ Nominal temp., 30minutes 25cycles $\uparrow\downarrow$ $+125^{\circ}\text{C} \pm 3^{\circ}\text{C}$ , 30minutes
Humidity (Steady state)	$\pm(1 \%+0.05 \Omega)$	Less than 50 m $\Omega$	Resistors shall be exposed at $60^{\circ}\text{C} \pm 2^{\circ}\text{C}$ and 90 % to 95 % relative humidity in a humidity test chamber for 1000 hours $\begin{smallmatrix} +48 \\ 0 \end{smallmatrix}$ hours.
Endurance at 70 °C	$\pm(3 \%+0.1 \Omega)$	Less than 50 m $\Omega$	Resistors shall be exposed at $70^{\circ}\text{C} \pm 2^{\circ}\text{C}$ for 1000 hours $\begin{smallmatrix} +48 \\ 0 \end{smallmatrix}$ hours. During this time, the rated voltage shall be applied intermittently for 1.5 hours ON, 0.5 hour OFF.
Load life in humidity	$\pm(3 \%+0.1 \Omega)$	Less than 50 m $\Omega$	Resistor shall be exposed at $60^{\circ}\text{C} \pm 2^{\circ}\text{C}$ and 90 % to 95 % relative humidity for 1000 hours $\begin{smallmatrix} +48 \\ 0 \end{smallmatrix}$ hours. During this time, the rated voltage shall be applied intermittently for 1.5 hours ON, 0.5 hour OFF.

### 9. Resistance value marking

No marking.

Subject	Spec. No.
Chip Resistor Array PRODUCT SPECIFICATION FOR INFORMATION	151-EXB-24V01VE
Part No.	
<b>EXB24V</b>	8-5

## 10. Common precautions in handling resistors



### Notice for use

- (1) This specification shows the quality and performance of a unit component. Before adoption, be sure to evaluate and verify the product mounting it in your product.
- (2) We take no responsibility for troubles caused by the product usage that is not specified in this specification.
- (3) In advance-notification to us is required in case you demand high reliability in the resistors because there is a possibility that a trouble or a failure in our resistor which is used in your transportation units (e.g. Trains, cars, ships, traffic signal equipment etc.), ocean floor-equipment, medical equipment, aerospace equipment, electrothermal goods, combustion and gas equipment, power station control equipment, information control equipment, rotating equipment, disaster and crime preventive equipment, various safety devices, and the equivalent equipment may cause critical damage occurrence such as loss of life or property.  
In addition, use fail-safe design as mentioned below for preventing extensive damage and for ensuring the safety:
  - \*Ensure safety by the system in which the protective circuits and/or protective equipment are installed.
  - \*Ensure safety by the system in which a single failure does not cause unsafety by installing such as redundant circuits.
- (4) When a dogma shall be occurred about safety for this product, be sure to inform us rapidly, operate your technical examination.
- (5) The product is designed to use in general standard applications of general electric equipment (AV products, household electric appliances, office equipment, information and communication equipment, etc.); hence, it do not take the use under the following special environments into consideration.  
Accordingly, the use in the following special environments, and such environmental conditions may affect the performance of the product; prior to use, verify the performance, reliability, etc. thoroughly.
  - 1) Use in liquids such as water, oil, chemical, and organic solvent.
  - 2) Use under direct sunlight, in outdoor or in dusty atmospheres.
  - 3) Use in places full of corrosive gases such as sea breeze, Cl<sub>2</sub>, H<sub>2</sub>S, NH<sub>3</sub>, SO<sub>2</sub>, and NO<sub>x</sub>.
  - 4) Use in environment with large static electricity or strong electromagnetic waves or strong radial ray.
  - 5) Where the product is close to a heating component, or where an inflammable such as a polyvinyl chloride wire is arranged close to the product.
  - 6) Where the resistor is sealed or coated with resin etc.
  - 7) Where solvent, water, or water-soluble detergent is used in cleaning free soldering and in flux cleaning after soldering. (Pay particular attention to water-soluble flux.)
  - 8) Use in such a place where the product is wetted due to dew condensation.
- (6) If transient load (heavy load in a short time) like pulse is expected to be applied, carry out evaluation and confirmation test with resistors actually mounted on your own board.  
When the load of more than rated power is applied under the load condition at steady state, it may impair performance and/or reliability of resistor. Never exceed the rated power and rated voltage. Temperature of resistors may become high even with specified conditions. Please confirm safety of heat from resistors on print circuit board and components around them.  
When the product shall be used under special condition, be sure to ask us in advance.
- (7) Halogen type (Chlorine type, Bromine type, etc.) or other high-activity flux is not recommended as the residue may affect performance or reliability of resistors.  
Strong acid flux, water soluble-flux and flux including fluorine ion shall not be used.
- (8) When soldering with soldering iron, never touch the body of the chip resistor with a tip of the soldering iron. When using a soldering iron with a tip at high temperature, solder for a time as short as possible. (three seconds or less up to 350 deg.C)
- (9) Avoid physical shock to the resistor and nipping of the resistor with hard tool (a pair of pliers or tweezers) as it may damage protective film or the body of resistor and may affect resistor's performance.
- (10) Avoid immersion of chip resistor in solvent for long time. Use solvent after the effect of immersion is confirmed.
- (11)Reflow soldering method shall apply to this product in principle.

Subject	Spec. No.
Chip Resistor Array PRODUCT SPECIFICATION FOR INFORMATION	151-EXB-24V01VE
Part No.	
<b>EXB24V</b>	8-6

### 11. Storage method

If the product is stored in the following environments and conditions, the performance and solderability may be badly affected. Avoid the storage in the following environments.

- (1) Storage in places full of corrosive gases such as sea breeze, Cl<sub>2</sub>, H<sub>2</sub>S, NH<sub>3</sub>, SO<sub>2</sub>, and NO<sub>x</sub>.
- (2) Storage in places exposed to direct sunlight.
- (3) Storage in places outside the temperature range of 5 °C to 35 °C and humidity range of 45% relative humidity to 85 % relative humidity.
- (4) Storage over a year after our delivery (This item also applies to the case where the storage method specified in item (1) to (3) has been followed.).

### 12. Laws and Regulations

- (1) This product has not been manufactured with any ozone-depleting chemical controlled under the Montreal Protocol.
- (2) This product complies with the RoHS Directive (Restriction of the use of certain Hazardous Substances in electrical and electronic equipment (DIRECTIVE 2002/95/EC)).
- (3) All materials used in this part are registered material under the Law Concerning the Examination and Regulation of Manufactures, etc. of Chemical substances.
- (4) All the materials used in this part contain no brominated materials of PBBOs or PBBs as the flame-retardant.
- (5) If you need the notice by letter of “A preliminary judgement on the Laws of Japan foreign exchange and Foreign Trade control”, be sure to let us know.

### 13. Production Place

Production Country : Japan

Production Plant : Circuit Components Business Division, Panasonic Corporation

Production Country : China

Production Plant : Panasonic Industrial Devices (Tianjin) Co., Ltd. (PIDTJ)

Subject Chip Resistor Array PRODUCT SPECIFICATION FOR INFORMATION	Spec. No. 151-EXB-24V01VE
Part No. <b>EXB24V</b>	8-7

## 14. Tape and Reel Package

### 14-1. Physical Dimensions

Structure and reel dimensions shall be as shown in the figure below.

In accordance with EIAJ ET-7200.

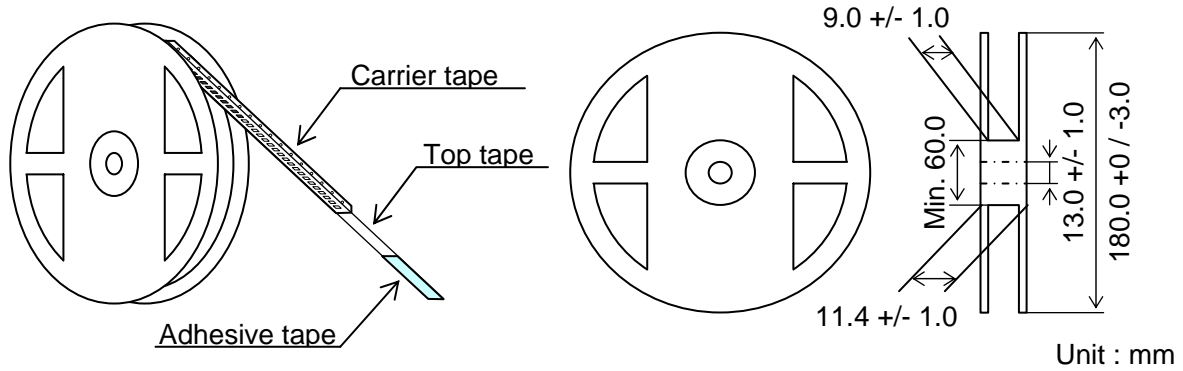

### 14-2. Carrier Tape Dimensions

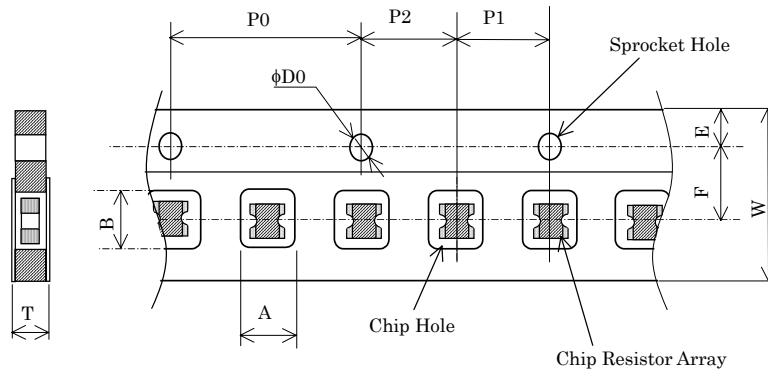

	A	B	W	F	E
(mm)	1.20±0.10	1.20±0.10	8.00±0.20	3.50±0.05	1.75±0.10
	P1	P2	P0	T	φD0
(mm)	2.00±0.10	2.00±0.05	4.00±0.10	0.52±0.05	1.50 <sup>+0.10</sup> <sub>0</sub>

### 14-3. Specification

#### 14-3-1. Taping

- (1) When the test shall be operated with the below conditions, peel strength should be 0.049N to 0.49N, should not have flash and tear after peeling.

<Test Method>

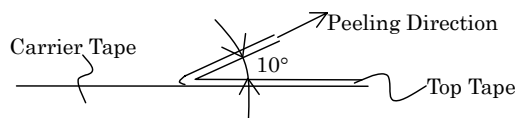

#### (2) Minimum Bending Radius

When carrier tape shall be bent by minimum bending radius (15 mm), no deflection of chip and no break of carrier tape. However minimum bending radius shall be tested for 1 times.

Subject Chip Resistor Array PRODUCT SPECIFICATION FOR INFORMATION	Spec. No. 151-EXB-24V01VE
Part No. <b>EXB24V</b>	8-8

(3) Resistance to climate

When resistors shall be exposed at  $60\text{ }^{\circ}\text{C} \pm 2\text{ }^{\circ}\text{C}$ , 90 % to 95 % relative humidity for 120 hours, no deflection of chip and no break off carrier tape.

When the top tape shall be peeled, tape should not have flash and tear.

14-3-2. Quantity in Taping: 10,000 pcs. / reel

14-3-3. Tape packaging

(1) Resistor side shall be facing upward.

(2) Chip resistor shall not be sticking to top tape and bottom tape.

(3) Chip resistors shall be easy to take out from carrier tape and chip hole or sprocket hole shall not have flash and break.

14-4. Outer Packaging

Quantity: 20 reels(Max.200,000 pcs.)

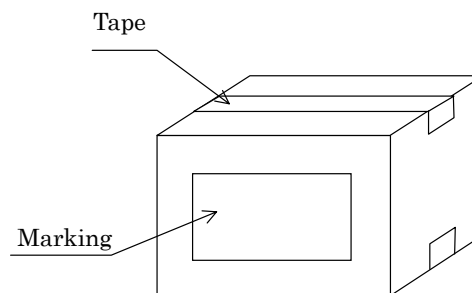

(1) When packaging quantity does not reach max quantity, the remaining empty space shall be buried with buffer material.

(2) When quantity shall be few, alternative packaging methods may used. No problem must occur during the exportation of the product..

14-5. Marking (Label)

Items listed below shall be displayed.

- Side of reel (Marking shall be on one side.)

(1)Part name (2)Part number (3)Quantity (4)Lot number (5)Maker name

(6)Production country

- Packaging box

(1)Customer name (2)Part name (3)Part number (4)Customer part number

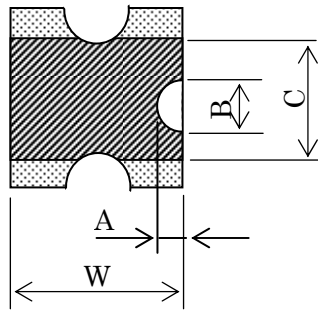
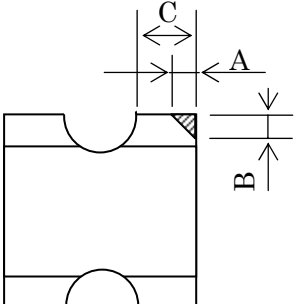
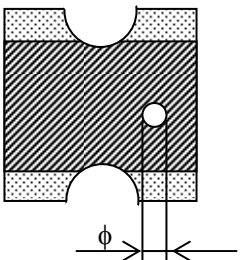
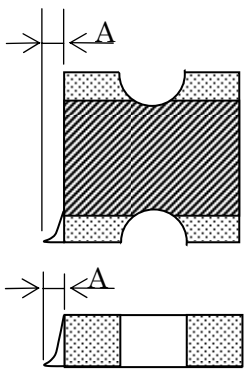

(5)Quantity (6)Maker name (7) Production country

<b>APPEARANCE QUALITY CRITERIA</b>	1-1
------------------------------------	-----

Item	Defect Criteria	Appearance Criteria	Remark
Resin Chipping		$A \leq W/8$ $B \leq C/2$	Both side chipping shall be judged defect
Terminal Chipping	 <p style="text-align: center;">Oblique line show chipping</p>	$A \leq C/4$ $B \leq \text{Top terminal width}$	
Pin Hole		One pin hole / chip resistor $\phi \leq 0.2 \text{ mm}$	This item is applied to pin holes which reach to the resistive materials
Flash		$A \leq 100 \mu\text{m}$	

## Looking for pricing, stock, or lifecycle information?

Click below to explore more details on WIN SOURCE:

-  [View EXB-24V473JX on WIN SOURCE](#)
-  [Panasonic Information](#)

## Optimize Your Supply Chain with WIN SOURCE Solutions

-  Global Sourcing Solution
-  Obsolete Management
-  Cost Control Management
-  Shortage Management
-  Alternative Solution
-  Excess Inventory Management