



**THE DATASHEET OF
6295-BCM-T-040-000**



LOW PRESSURE DIGITAL AND ANALOG SENSOR

SM7000/SM6000/SM5000 Series

Performance Specification

1. Calibrated Pressure Ranges

Series	Pressure Type	Output Type	P _{MIN} (PSI)	P _{MAX} (PSI)
SM7291	Gage	Digital & Analog	0	+0.14 to +0.29
SM7231	Gage	Digital		
SM7391	Differential*	Digital & Analog	-0.29 to -0.07	+0.07 to +0.29
SM7331	Differential*	Digital		
SM7491	Asymmetric**	Digital & Analog	-0.29 to 0	0 to +0.29
SM7431	Asymmetric**	Digital		
SM6291	Gage	Digital & Analog	0	+0.3 to +0.79
SM6231	Gage	Digital		
SM6391	Differential*	Digital & Analog	-0.79 to -0.3	+0.3 to +0.79
SM6331	Differential*	Digital		
SM6491	Asymmetric**	Digital & Analog	-0.79 to 0	0 to +0.79
SM6431	Asymmetric**	Digital		
SM5291	Gage	Digital & Analog	0	+0.8 to +2.49
SM5231	Gage	Digital		
SM5391	Differential*	Digital & Analog	-2.49 to -0.8	+0.8 to +2.49
SM5331	Differential*	Digital		
SM5491	Asymmetric**	Digital & Analog	-2.49 to 0	0 to +2.49
SM5431	Asymmetric**	Digital		

Comments:

*For differential devices the absolute value of P_{MIN} must match absolute value of P_{MAX}.

**For asymmetric devices the delta between P_{MAX} and P_{MIN} must be at least 0.14 PSI.

2. Absolute Maximum Ratings

All parameters are specified at VDD = 3.3 V / 5.0 V supply voltage at 25°C, unless otherwise noted.

Characteristic	Symbol	Min	Max	Units
Compensated Temperature	T _{COMP}	-20	85	°C
Operating Temperature ^(a)	T _{OP}	-40	105	°C
Storage Temperature ^(a)	T _{STG}	-40	125	°C
Supply Voltage	V _{DD}	-0.3	6	V
Media Compatibility ^(a)		Clean, dry air compatible with wetted materials ^(b)		

Burst pressure and proof pressure by pressure range and series

Max Operating Pressure Range P _{MAX} (PSI)	Series	Proof Pressure ^(a, c) P _{Proof} (PSI)	Burst Pressure ^(a, d) P _{Burst} (PSI)
0.07 to 0.29	7X91 and 7X31	1.5	3
0.3 to 0.79	6X91 and 6X31	4.5	6
0.8 to 2.49	5X91 and 5X31	12	15

Notes:

- Tested on a sample basis.
- Wetted materials include silicon, epoxy, RTV, gold and aluminum.
- Proof pressure is defined as the maximum pressure to which the device can be taken and still perform within specifications after returning to the operating pressure range.
- Burst pressure is the pressure at which the device suffers catastrophic failure resulting in pressure loss through the device.

LOW PRESSURE DIGITAL AND ANALOG SENSOR

SM7000/SM6000/SM5000 Series

3. ESD

Description	Condition	Symbol	Min	Max	Units
ESD HBM Protection at all Pins	AEC Q100-002 (HBM) chip level test	$V_{ESD(HBM)}$	-2	2	kV

4. External Components

Description	Symbol	Min	Typ	Max	Units
Supply bypass capacitor	C_{VDD}		100		nF

5. Recommended Operating Conditions

The recommended operating conditions must not be exceeded in order to provide proper functionality of the device. All parameters specified in the following sections refer to these recommended operating conditions unless stated otherwise.

Description	Symbol	Min	Typ	Max	Units
Supply Voltage	V_{DD}	4.5 3.0	5.0 3.3	5.5 3.6	V
Low level input voltage at Digital I/O	$V_{IN,I2C,lo}$	-0.3		0.9	V
High level input voltage at Digital I/O	$V_{IN,I2C,hi}$	$0.8 * V_{DD}$		$V_{DD}+0.3$	V
Current Consumption with analog output (only applicable for XX91)			4.5		mA
Current Consumption without analog output			3		mA

6. Operating Characteristics Table

All parameters are specified at $V_{DD} = 3.3\text{ V} / 5.0\text{ V}$ supply voltage at 25°C , unless otherwise noted.

Characteristic	Series	Symbol	Min	Typ	Max	Units
Digital Pressure Output @ $P_{MIN}^{(e)}$	All	$DOUT_{MIN}$		-26,215		Counts
Digital Pressure Output @ $P_{MAX}^{(e)}$		$DOUT_{MAX}$		26,214		Counts
Digital Full Scale Span ^(e)		DFS		52,429		Counts
Resolution				16		Bits
Digital Output Total Error Band ^(f, g, h)		DACC	-1		+1	%FS
Analog Pressure Output @ $P_{MIN}^{(e)}$	XX91	$AOUT_{MIN}$		10		%VDD
Analog Pressure Output @ $P_{MAX}^{(e)}$		$AOUT_{MAX}$		90		%VDD
Analog Full Scale Span		AFS		80		%VDD
Analog Output Accuracy ^(f, g, h)		AACC	-1.5		+1.5	%FS

Notes:

- e) Only the typical values are shown here. However, the output values can be customized or changed upon request.
- f) The total error band specification applies over all operating conditions in dry clean air. This specification includes the combination of linearity, repeatability, and hysteresis errors over pressure, temperature, and voltage.
- g) Maximum 10-year zero pressure offset shift < $\pm 2\%$ FS based on 1000 hours of HTOL, TC and THB testing.
- h) For less demanding applications, devices with relaxed accuracy specifications are available.

LOW PRESSURE DIGITAL AND ANALOG SENSOR

SM7000/SM6000/SM5000 Series

7. Digital Output Transfer Function

$$P_{\text{read}} = P_{\text{min}} + \frac{P_{\text{DOUT}_{\text{read}}} - P_{\text{DOUT}_{\text{min}}}}{P_{\text{DOUT}_{\text{max}}} - P_{\text{DOUT}_{\text{min}}}} (P_{\text{max}} - P_{\text{min}})$$

$$P_{\text{read}} = P_{\text{min}} + \frac{P_{\text{DOUT}_{\text{read}}} - P_{\text{DOUT}_{\text{min}}}}{P_{\text{DOUT}_{\text{max}}} - P_{\text{DOUT}_{\text{min}}}} (P_{\text{max}} - P_{\text{min}})$$

P_{min} and P_{max} are minimum and maximum rating pressure in specified pressure unit on the specification.

$P_{\text{DOUT}_{\text{min}}}$ and $P_{\text{DOUT}_{\text{max}}}$ are minimum and maximum digital counts on the specification.

$P_{\text{DOUT}_{\text{read}}}$ is digital reading from the output and P_{read} is the converted pressure output based on $P_{\text{DOUT}_{\text{read}}}$.

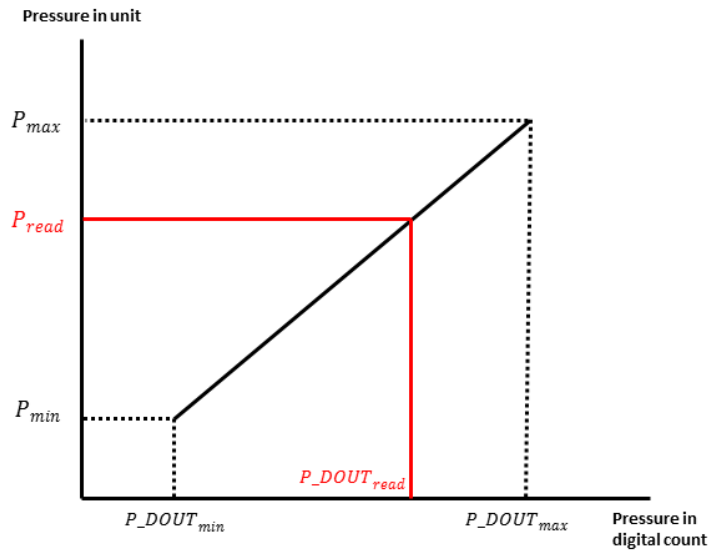

For example, the P_{min} and P_{max} for the sensor are specified as -15 psi and +15 psi. The DOUT_{min} and DOUT_{max} are 26214 and +26214. So,

$$P_{\text{read}} = -15 + \frac{\text{DOUT}_{\text{read}} + 26214}{52428} \times 30 \text{ psi}$$

LOW PRESSURE DIGITAL AND ANALOG SENSOR

SM7000/SM6000/SM5000 Series

8. Package Reference

SOIC-16 (C) Dual Vertical Package Dimensions

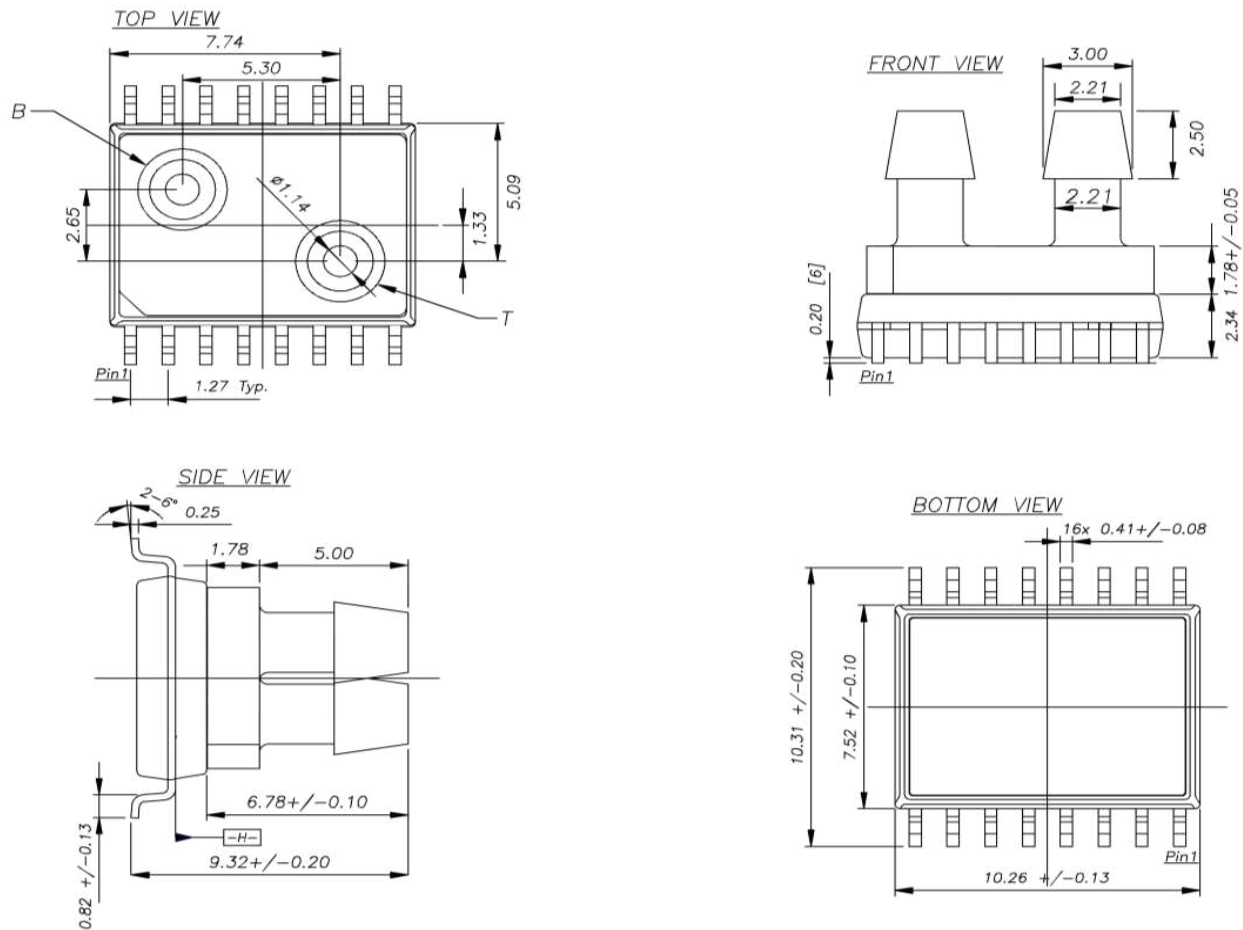

Lot number identification on top side

Notes:

- All dimensions in units of [mm]
- Moisture Sensitivity Level (MSL): Level 3
- Wetted materials: Silicon, glass, gold, aluminum, copper, silicone, epoxy, mold compound.
- [B] is tube connected to bottom side of sensor die.
- [T] is tube connected to top side of sensor die. Topside pressure is positive pressure. An increase in topside pressure will result in an increase in sensor output.
- Bottom plate is stainless steel.
- Electrically isolate the bottom metal cover, do not connect to the cover and keep the board underneath free from electrical circuits.
- Robust JEDEC SOIC-16 package for automated assembly
- Manufactured according to ISO9001, ISO14001 and ISO/TS 16949 standards

LOW PRESSURE DIGITAL AND ANALOG SENSOR

SM7000/SM6000/SM5000 Series

SOIC-16 (C) Dual Horizontal Package Dimensions

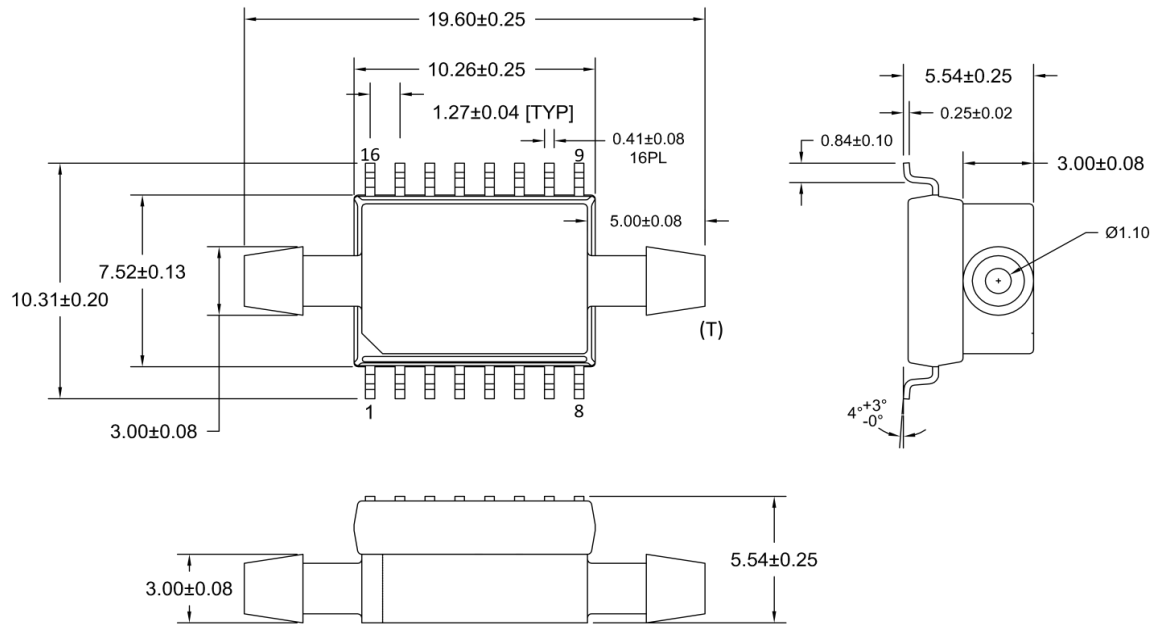

Dimensions are in mm

Lot number identification on top side

Notes:

- All dimensions in units of [mm]
- Moisture Sensitivity Level (MSL): Level 3
- Wetted materials: Silicon, glass, gold, aluminum, copper, silicone, epoxy, mold compound.
- [B] is tube connected to bottom side of sensor die.
- [T] is tube connected to top side of sensor die. Topside pressure is positive pressure. An increase in topside pressure will result in an increase in sensor output.
- Bottom plate is stainless steel
- Robust JEDEC SOIC-16 package for automated assembly
- Electrically isolate the bottom metal cover, do not connect to the cover and keep the board underneath free from electrical circuits.
- Manufactured according to ISO9001, ISO14001 and ISO/TS 16949 standards

LOW PRESSURE DIGITAL AND ANALOG SENSOR

SM7000/SM6000/SM5000 Series

Applications Circuit

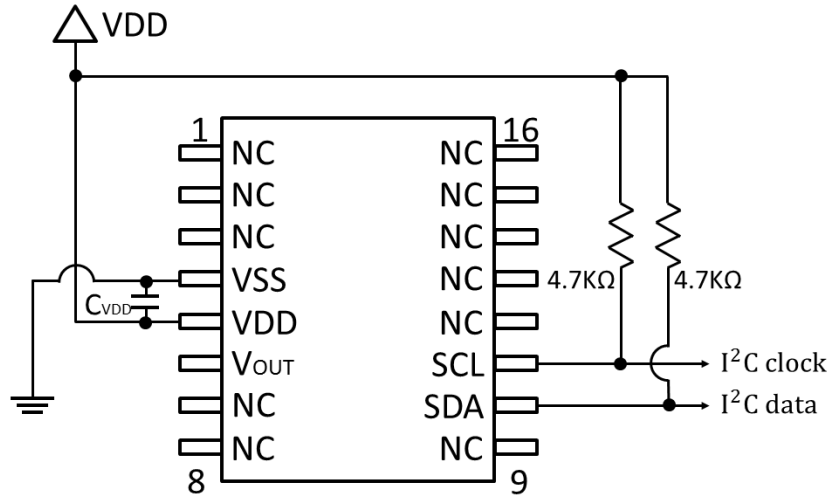

Pin No	Pin Function (XX91)	Pin Function (XX31)
1	NC (No Connect)	NC (No Connect)
2	NC	NC
3	NC	NC
4	VSS	VSS
5	VDD	VDD
6	VOUT (Analog Output)	NC
7	NC	NC
8	NC	NC
9	NC	NC
10	SDA	SDA
11	SCL	SCL
12	NC	NC
13	NC	NC
14	NC	NC
15	NC	NC
16	NC	NC

Notes:

- Do not connect to NC pins

LOW PRESSURE DIGITAL AND ANALOG SENSOR

SM7000/SM6000/SM5000 Series

9. Part Description Key

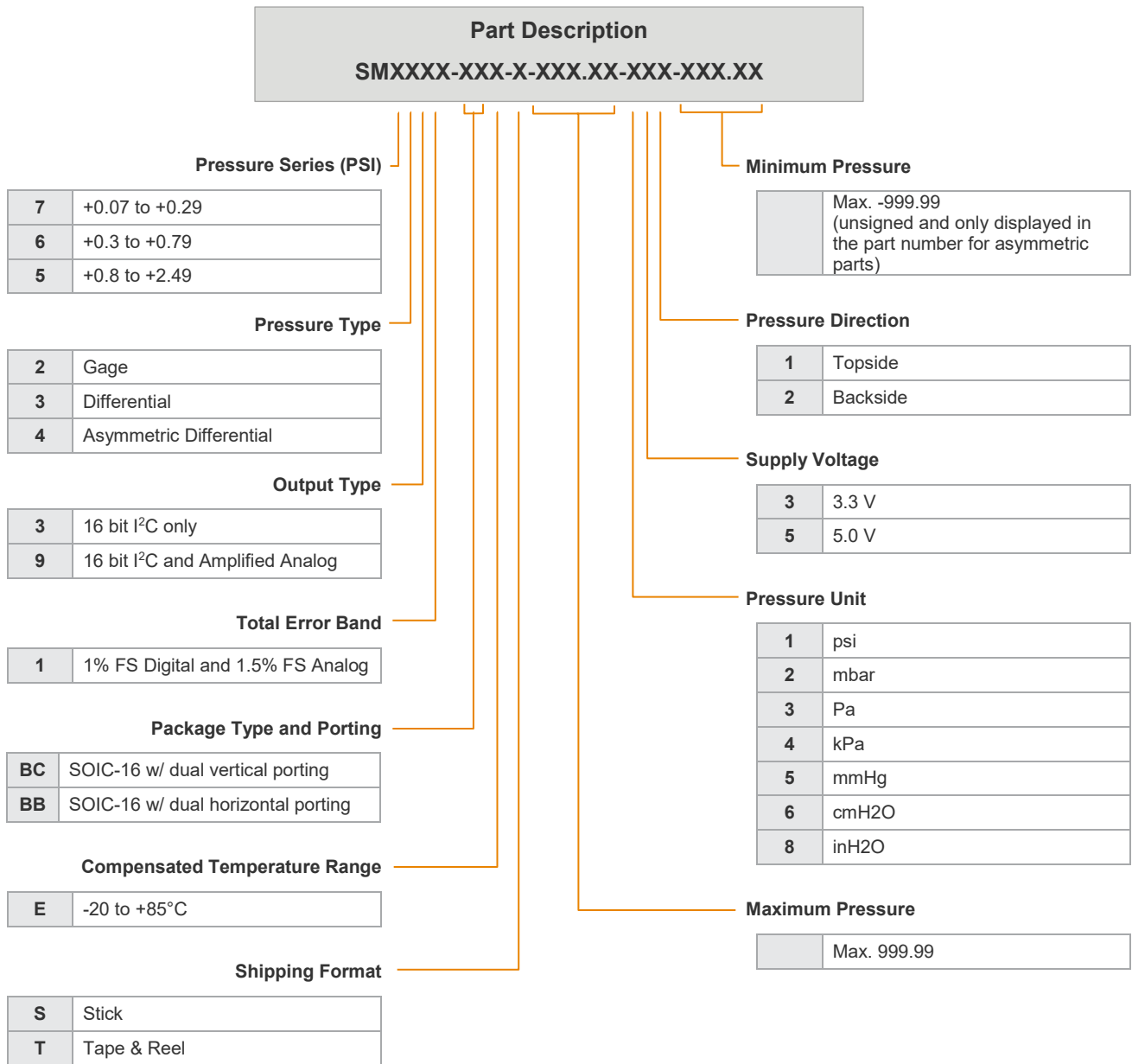

LOW PRESSURE DIGITAL AND ANALOG SENSOR

SM7000/SM6000/SM5000 Series

10. Ordering Information (Example Configurations)

Part Number	Part Description	Pressure Range	Output Type	Package Configuration	Voltage	Shipping ^(a)
7391-BCE-S-500-000	SM7391-BCE-S-500.00-331	-500 to +500 Pa	Digital & Analog	SOIC-16 Dual Vertical	3.3 V	Sticks (45 parts/stick)
7291-BCE-S-001-000	SM7291-BCE-S-001.00-431	0 to +1 kPa	Digital & Analog			
SM7391-BCE-S-500	SM7391-BCE-S-500.00-331	-500 to +500 Pa	Digital & Analog			
6391-BCE-S-040-000	SM6391-BCE-S-040.00-631	-40 to +40 cmH ₂ O	Digital & Analog			
5391-BCE-S-100-000	SM5391-BCE-S-100.00-631	-100 to +100 cmH ₂ O	Digital & Analog			
5291-BCE-S-100-000	SM5291-BCE-S-100.00-631	0 to +100 cmH ₂ O	Digital & Analog			

Notes:

- a) All parts also available in shipping configuration Tape & Reel (SOIC-16 Dual Horizontal 500 parts/reel; SOIC-16 Dual Vertical 350 parts/reel), see section 10. Part Numbering Key for ordering information
- b) **The above table shows example configurations, not all available part numbers are listed. Contact Customer Care (customercare.mlpt@te.com) and provide configuration information based on part numbering key to order other configurations.**
- c) **If support is needed during the part selection process, please contact the Sensor Qualification Team (sensorsqt@te.com).**

LOW PRESSURE DIGITAL AND ANALOG SENSOR

SM7000/SM6000/SM5000 Series

11. I²C Communication protocol

11.1 I²C Electrical Table

Description	Condition	Symbol	Min	Typ	Max	Units
SDA output low voltage	$I_{SDA} = 3 \text{ mA}$	$V_{SDA,OL}$	0		0.4	V
Low-to-High transition threshold	pins SA0, SCL	$V_{SDA,LH}$	0.5	0.6	0.7	*VDD
High-to-Low transition threshold	pins SA0, SCL	$V_{SDA,HL}$	0.3	0.4	0.5	*VDD
I ² C clock frequency ^{**)}		f_{SCL}	0		400	kHz
Bus free time between a START and STOP condition ^{*)}		t_{BUSF}	1300			ns
Clock low time ^{*)}		t_{LO}	1300			ns
Clock high time ^{*)}		t_{HI}	600			ns
START condition hold time ^{*)}		t_{SH}	100			ns
Data setup time ^{*)}		t_{SU}	100			ns
Data hold time ^{*)}		t_H	0			ns
Setup time for repeated START condition ^{*)}		t_{RSH}	600			ns
Setup time for STOP condition ^{*)}		t_{PSU}	600			ns
Rise time of SDA and SCL signals ^{*)}		t_R			300	ns
Fall time of SDA and SCL signals ^{*)}		t_F			300	ns

^{*)} Not tested in production

^{**)} For I²C bus capacitance load >100pF maximum possible clock frequency is 100kHz

11.2 I²C Interface

The sensor features an I²C slave interface. This interface provides direct access to registers of the memory of the pressure sensor. An external I²C master (e.g. a microcontroller) can read from and write to memory addresses (registers) of the device using the following commands:

- **Random write:** Sets a memory address and writes data to consecutive memory addresses of the device starting at the set memory address.
- **Random read:** Sets a memory address and reads data from consecutive memory addresses of the device starting at the set memory address.
- **Read last:** Reads data from the device starting at the last memory address set by the master. This facilitates repeated reading of the same memory addresses without transmitting a memory address first.

All reads/writes must start at word aligned addresses (i.e. LSB of memory address equals 0) and read/write an even number of bytes.

I²C Interface Timing Diagram:

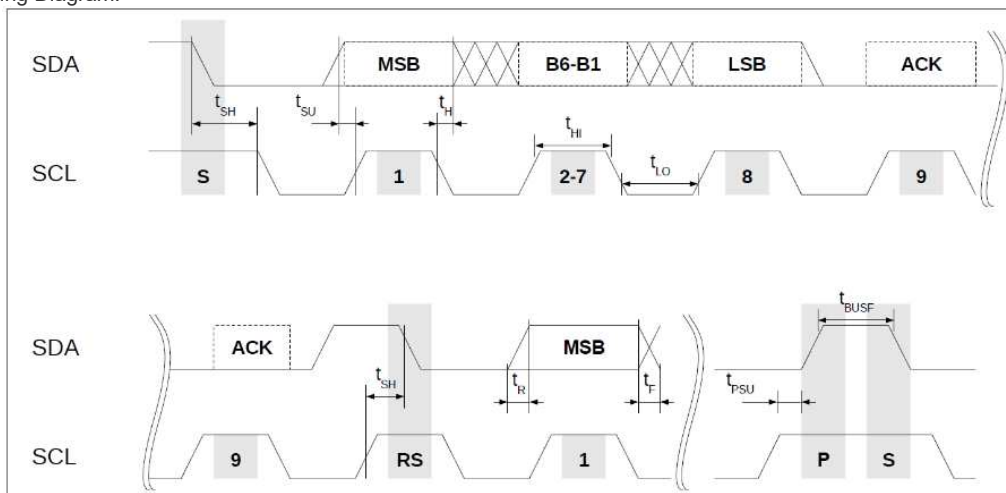

LOW PRESSURE DIGITAL AND ANALOG SENSOR

SM7000/SM6000/SM5000 Series

11.3 I²C Command Format

The sensor uses a standard 7-bit I²C slave address field. The LSB of the slave address specifies the frame type used to perform read and write operations.

For LSB = 0 the protocol is compatible to standard I²C EEPROMs, for LSB = 1 the protocol is extended by a CRC protection. Thus, each device occupies two I²C addresses: even addresses are for standard EEPROM compatible protocols and odd addresses are for CRC protected protocols. Unprotected and CRC protected frames can be interleaved.

The two different frame types - standard EEPROM (without CRC) or CRC protected - are shown in the next two figures.

I²C Read / Write Commands - Standard EEPROM compatible protocol

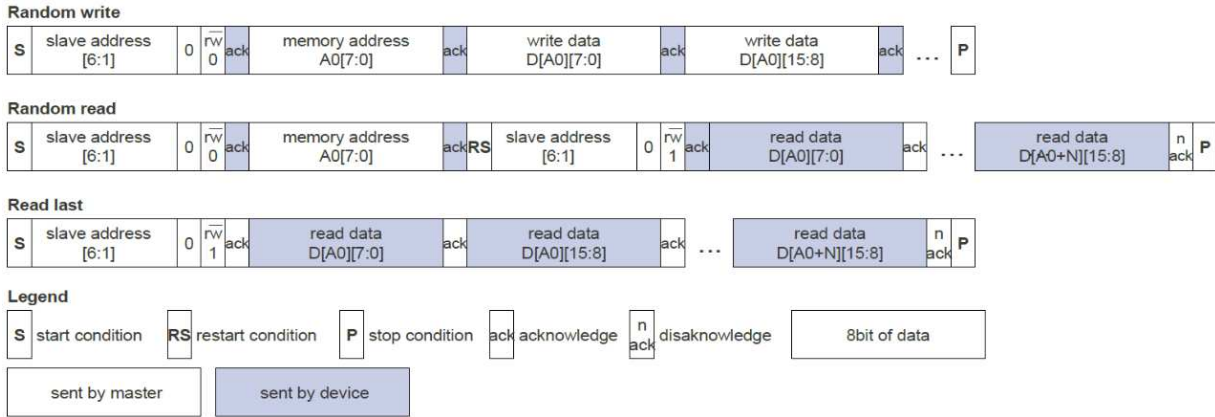

I²C Read / Write Commands - CRC protected protocol

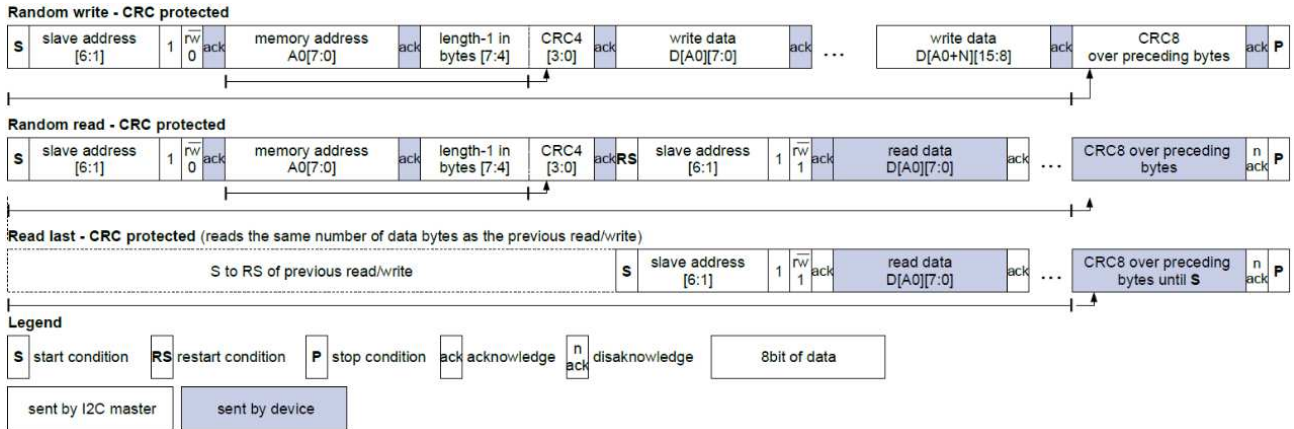

The memory address field sets the byte address of the first memory location to be read from or written to. Only 16-bit-word aligned reads/writes are supported, i.e. the LSB of memory address has to be zero always. The read/write data is transferred MSB first, low byte before high byte.

The length field (bits[7:4]) required for CRC protected frames specifies the number of data bytes to be transferred decremented by one, i.e. a value of 0001b corresponds to two bytes. All frames must transfer an even number of bytes. The maximum length for CRC protected read/write frames is 4 bytes (2 registers). For unprotected frames the length is unlimited.

The CRC4 and CRC8 for redundancy check are computed in the same bit and byte order as the transmission over the bus. The polynomials employed are:

- CRC4: polynomial 0x03; initialization value: 0x0F
- CRC8: polynomial 0xD5; initialization value: 0xFF

If a CRC errors occurs, then the event bit com_crc_error in the STATUS register will be set.

LOW PRESSURE DIGITAL AND ANALOG SENSOR

SM7000/SM6000/SM5000 Series

11.4 I²C Command Examples

For all examples below the 7-bit device slave address used is 0x6C for unprotected commands, and 0x6D for CRC protected commands, respectively.

The command sequence following describes an unprotected Read command (without CRC) of 3 subsequent 16-bit words starting at memory address 0x2E to read the corrected IC temperature, corrected pressure signal, and (synchronized) status bits of the sensor.

Byte #	0	1	2	3	4	5	6	7	8
SBM (sent by master)	0xD8	0x2E	0xD9						
SBM comment	slave address 6C + LSB = 0 for Write	memory address	slave address 6C + LSB = 1 for Read						
SBS (sent by sensor)				0xF2	0x7D	0xEA	0x82	0x1E	0x00
SBS comment				DSP_T (Lo-Byte) ad. 0x2E	DSP_T (Hi-Byte)	DSP_S (Lo-Byte) ad. 0x30	DSP_S (Hi-Byte)	sync'ed Status (b7 - b0) ad. 0x32	sync'ed Status (b15 - b8)

Random Read – protected by CRC:

The following sequence describes the CRC protected version of reading 3 subsequent 16-bit words starting at memory address 0x2E to read the corrected IC temperature, corrected pressure signal, and (synchronized) status bits of the sensor.

Byte #	0	1	2	3	4	5	6	7	8
SBM (sent by master)	0xDA	0x50	0x39	0xDB					
SBM comment	slave address 6D + LSB = 0 for Write	memory address	3: length = 4Byte 9: CRC4	slave address 6D + LSB = 1 for Read					
SBS (sent by sensor)					0x0C	0x00	0xF3	0x61	0xA9
SBS comment					SER0 (Lo-Byte) ad. 0x50	SER0 (Hi-Byte)	SER1 (Lo-Byte) ad. 0x52	SER1 (Hi-Byte)	CRC8 (calc'd)

Random Write:

The following sequence writes one 16-bit word to address 0x22 (without CRC protection). This will copy 0x6C32 into the command register CMD to move the component to Sleep Mode.

Byte #	0	1	2	3
SBM (sent by master)	0xD8	0x22	0x32	0x6C
SBM comment	slave address 6C + LSB = 0 for Write	memory address	Lo-Byte written to CMD[7:0]	Hi-Byte written to CMD[15:8]
SBS (sent by sensor)				
SBS comment				

LOW PRESSURE DIGITAL AND ANALOG SENSOR

SM7000/SM6000/SM5000 Series

Random Write - protected with CRC:

The next example describes a Write of one 16-bit word (contents 0xCF9E) with CRC protection to address 0x36 to clear events in the STATUS register.

Byte #	0	1	2	3	4	5
SBM (sent by master)	0xDA	0x36	0x16	0x9E	0xCF	0x0E
SBM comment	slave address 6D + LSB = 0 for Write	memory address	1: length = 2Byte 1: CRC4	STATUS (Lo-Byte) ad. 0x36	STATUS (Hi-Byte)	CRC8 (calculated)
SBS (sent by sensor)						
SBS comment						

11.5 Register Descriptions

Register Read or Write are performed via the digital communication interface. After power-up of the IC all registers except STATUS and CMD are write protected.

Command register:

0x22	CMD			
bits	name	default	rw	description
15:0	cmd	0	w	Writing to this register controls the state of the device. 0x6C32: SLEEP Mode Initiate the power state SLEEP, powering down the ASIC 0xB169: RESET Performs a reset. After reset the power-up sequence will be executed, i.e. the registers are loaded with data from the configuration memory, also a CRC check is performed.

Temperature register:

0x2E	DSP_T			
bits	name	default	rw	description
15:0	dsp_t		r	Corrected temperature measurement value of the sensor. Whenever this register is updated with a new measurement the STATUS.dsp_t_up event bit is set.

Pressure register:

0x30	DSP_S			
bits	name	default	rw	description
15:0	dsp_s		r	Corrected pressure measurement value of the sensor. Whenever this register is updated with a new measurement the STATUS.dsp_s_up event bit is set.

The registers DSP_T and DSP_S contain invalid data after power-up until the first temperature and pressure values have been measured by the device and transferred to these registers. In case a NVM CRC error occurred, the DSP_T and DSP_S registers would never be updated. Thus, after power up it is necessary to wait until the STATUS.dsp_s_up and dsp_t_up bits have been set at least once before using the temperature or pressure data. It is not sufficient to wait just for a fixed time delay.

LOW PRESSURE DIGITAL AND ANALOG SENSOR

SM7000/SM6000/SM5000 Series

Status register - synchronized:

0x32	STATUS_SYNC					
bits	name	default	rw	type	description	
0	idle	0	rw	status	STATUS.idle	
1	- reserved -	0	rw	event	reserved	
2	- reserved -	0	rw	event	reserved	
3	dsp_s_up	0	rw	event	when DSP_S is read STATUS.dsp_s_up is copied here	
4	dsp_t_up	0	rw	event	when DSP_T is read STATUS.dsp_t_up is copied here	
5	- reserved -	0	rw	status	reserved	
6	- reserved -	0	rw	status	reserved	
7	bs_fail	0	rw	event	STATUS.bs_fail	
8	bc_fail	0	rw	event	STATUS.bc_fail	
9	- reserved -	0	rw	event	reserved	
10	dsp_sat	0	rw	status	STATUS.dsp_sat	
11	com_crc_error	0	rw	event	STATUS.com_crc_error	
12	- reserved -	0	rw	status	reserved	
13	- reserved -	0	rw	status	reserved	
14	dsp_s_missed	0	rw	event	STATUS.dsp_s_missed	
15	dsp_t_missed	0	rw	event	STATUS.dsp_t_missed	

The bits STATUS_SYNC[15:5,0] are identical to the bits STATUS[15:5,0].

The bits STATUS_SYNC[4:3] are copied from the STATUS register when the corresponding DSP registers are read. First reading the DSP registers and then STATUS_SYNC confirms that both values are consistent to each other.

The synchronized status STATUS_SYNC register can be used to continuously poll the pressure, temperature and status of the device with a single read command by reading three 16 bit words starting at address 0x2E. By evaluating STATUS_SYNC.dsp_t_up and STATUS_SYNC.dsp_s_up it can be determined if the values in DSP_T and DSP_S acquired during the same read contain recently updated temperature or pressure values.

Status register:

0x36	STATUS					
bits	name	default	rw	type ¹	description	
0	idle	0	rw	status	0: chip in busy state 1: chip in idle state	
1	- reserved -	0	rw	event	reserved	
2	- reserved -	0	rw	event	reserved	
3	dsp_s_up	0	rw	event	1: DSP_S register has been updated. Cleared when DSP_S is read	
4	dsp_t_up	0	rw	event	1: DSP_T register has been updated. Cleared when DSP_T is read.	
5	- reserved -	0	rw	status	reserved	
6	- reserved -	0	rw	status	reserved	
7	bs_fail	0	rw	event	1: bridge supply failure occurred	
8	bc_fail	0	rw	event	1: sensor bridge check failure occurred	
9	- reserved -	0	rw	event	reserved	
10	dsp_sat	0	rw	status	1:a DSP computataion leading to current DSP_T or DSP_S values was saturated to prevent overflow	
11	com_crc_error	0	rw	event	1:communication CRC error	
12	- reserved -	0	rw	status	reserved	
13	- reserved -	0	rw	status	reserved	
14	dsp_s_missed	0	rw	event	1:dsp_s_up was 1 when DSP_S updated	
15	dsp_t_missed	0	rw	event	1:dsp_t_up was 1 when DSP_T updated	

- "Event" type flags remain set until cleared by writing '1' to the respective bit position in STATUS register (not STATUS_SYNC). Writing 0xFFFF to the STATUS register will clear all event bits.
- "Status" type flag represents a condition of a hardware module of the IC and persists until the condition has disappeared.

LOW PRESSURE DIGITAL AND ANALOG SENSOR

SM7000/SM6000/SM5000 Series

Serial Number register 0:

0x50	SER0			
bits	name	default	rw	description
15:0	ser0		r	Serial number of the IC, Lo-Word

Serial Number register 1:

0x52	SER1			
bits	name	default	rw	description
15:0	ser1		r	Serial number of the IC, Hi-Word

12. Qualification Standards

REACH Compliant
RoHS Compliant
PFOS/PFOA Compliant
For qualification specifications



[CLICK HERE >](#)
CONNECT WITH A SPECIALIST

GLOBAL
Tel +1 408 577 0100
customercare.mlpt@te.com

te.com/sensors

TE Connectivity, TE, TE Connectivity (logo) and Every Connection Counts are trademarks. All other logos, products and/or company names referred to herein might be trademarks of their respective owners

The information given herein, including drawings, illustrations and schematics which are intended for illustration purposes only, is believed to be reliable. However, TE Connectivity makes no warranties as to its accuracy or completeness and disclaims any liability in connection with its use. TE Connectivity's obligations shall only be as set forth in TE Connectivity's Standard Terms and Conditions of Sale for this product and in no case will TE Connectivity be liable for any incidental, indirect or consequential damages arising out of the sale, resale, use or misuse of the product. Users of TE Connectivity products should make their own evaluation to determine the suitability of each such product for the specific application.

© 2020 TE Connectivity Corporation. All Rights Reserved.
Version 05/2021



Looking for pricing, stock, or lifecycle information?

Click below to explore more details on WIN SOURCE:

 [View 6295-BCM-T-040-000](#) on WIN SOURCE

 [TE Connectivity](#) Information

Optimize Your Supply Chain with WIN SOURCE Solutions

-  Global Sourcing Solution
-  Obsolete Management
-  Cost Control Management
-  Shortage Management
-  Alternative Solution
-  Excess Inventory Management