



**THE DATASHEET OF  
UUQ1C101MCL1GS**



# ALUMINUM ELECTROLYTIC CAPACITORS



Chip Type, For Audio Equipment  
Wide Temperature Range



- Chip type acoustic series within the wide temperature range.
- Applicable to automatic mounting machine fed with carrier tape.
- Compliant to the RoHS directive (2011/65/EU, (EU)2015/863).
- AEC-Q200 Qualified. Please contact us for details.

## Specifications

Item	Performance Characteristics						
Category Temperature Range	-40 to +105°C						
Rated Voltage Range	6.3 to 50V						
Rated Capacitance Range	1 to 1000μF						
Capacitance Tolerance	±20% (120Hz, 20°C)						
Leakage Current ※	After 1 minute's application of rated voltage at 20°C, leakage current is not more than 0.03 CV or 4 (μA), whichever is greater.						
Tangent of loss angle (tan δ)	Measurement frequency : 120Hz at 20°C						
	Rated voltage (V)	6.3	10	16	25	35	50
Stability at Low Temperature	Measurement frequency : 120Hz						
	Rated voltage (V)	6.3	10	16	25	35	50
	Impedance ratio (max.)	Z(-25°C) / Z(+20°C)	4	3	2	2	2
Endurance	The specifications listed at right shall be met when the capacitors are restored to 20°C after the rated voltage is applied for 1000 hours at 105°C.						
	Capacitance change	Within ±20% of the initial capacitance value					
Shelf Life	After storing the capacitors under no load at 105°C for 1000 hours and then performing voltage treatment based on JIS C 5101-4 clause 4.1 at 20°C, they shall meet the specified values for the endurance characteristics listed above.						
	tan δ	200% or less than the initial specified value					
Resistance to soldering heat	The capacitors are kept on a hot plate for 30 seconds, which is maintained at 250°C. The capacitors shall meet the characteristic requirements listed at right when they are removed from the plate and restored to 20°C.						
	Leakage current	Less than or equal to the initial specified value					
Marking	Black print on the case top.						

※ I : Leakage Current (μA), C : Rated Capacitance (μF), V : Rated Voltage (V)

## Chip Type

## Type numbering system (Example : 6.3V 100μF)

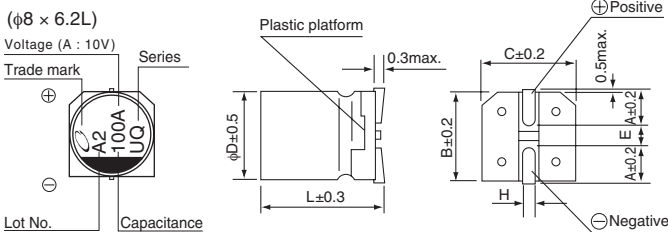
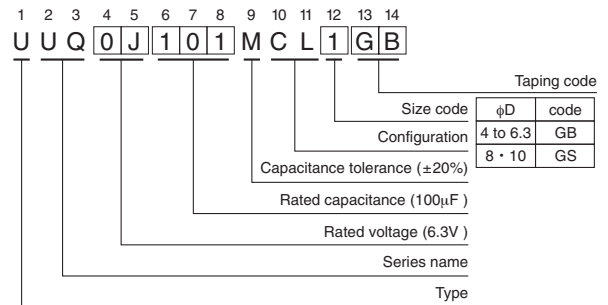
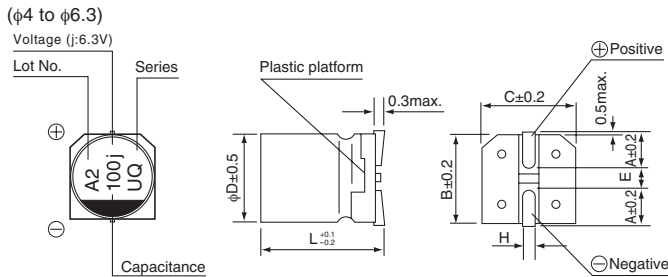

φD × L	4 × 5.4	5 × 5.4	6.3 × 5.4	8 × 6.2	8 × 10	10 × 10
A	1.8	2.1	2.4	3.3	2.9	3.2
B	4.3	5.3	6.6	8.3	8.3	10.3
C	4.3	5.3	6.6	8.3	8.3	10.3
E	1.0	1.3	2.2	2.3	3.1	4.5
L	5.4	5.4	5.4	6.2	10	10
H	0.5 to 0.8	0.5 to 0.8	0.5 to 0.8	0.5 to 0.8	0.8 to 1.1	0.8 to 1.1

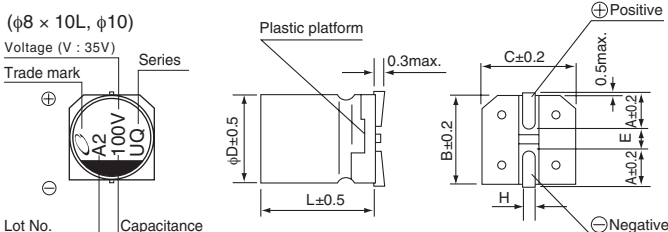

Voltage	6.3	10	16	25	35	50
Code	j	A	C	E	V	H

## Frequency coefficient of rated ripple current

Frequency	50 Hz	120 Hz	300 Hz	1 kHz	10 kHz or more
Coefficient	0.70	1.00	1.17	1.36	1.50

● Dimension table in next page.

UUQ

## ■ Dimensions

Rated Voltage (V) (code)	Rated Capacitance (μF)	Case Size φD×L (mm)	tan δ	Leakage Current (μA) (at 20°C after 1 minute)	Rated Ripple (mArms) (105°C/120Hz)	Part Number
6.3 (0J)	22	4×5.4	0.30	4.158	22	UUQ0J220MCL1GB
	33	5×5.4	0.30	6.237	30	UUQ0J330MCL1GB
	47	5×5.4	0.30	8.883	36	UUQ0J470MCL1GB
	100	6.3×5.4	0.30	18.9	60	UUQ0J101MCL1GB
	220	8×6.2	0.30	41.58	102	UUQ0J221MCL1GS
	220	8×10	0.30	41.58	210	UUQ0J221MCL6GS
	330	8×6.2	0.30	62.37	102	UUQ0J331MCL1GS
	330	8×10	0.30	62.37	210	UUQ0J331MCL6GS
	470	8×10	0.30	88.83	210	UUQ0J471MCL1GS
	470	10×10	0.30	88.83	310	UUQ0J471MCL6GS
	1000	10×10	0.30	189	310	UUQ0J102MCL1GS
10 (1A)	10	4×5.4	0.26	4	22	UUQ1A100MCL1GB
	22	5×5.4	0.26	6.6	27	UUQ1A220MCL1GB
	33	5×5.4	0.26	9.9	35	UUQ1A330MCL1GB
	47	6.3×5.4	0.26	14.1	46	UUQ1A470MCL1GB
	100	6.3×5.4	0.26	30	60	UUQ1A101MCL1GB
	100	8×6.2	0.26	30	90	UUQ1A101MCL6GS
	220	8×6.2	0.26	66	102	UUQ1A221MCL1GS
	220	8×10	0.26	66	210	UUQ1A221MCL6GS
	330	8×10	0.26	99	210	UUQ1A331MCL1GS
	330	10×10	0.26	99	310	UUQ1A331MCL6GS
	470	8×10	0.26	141	210	UUQ1A471MCL1GS
470	10×10	0.26	141	310	UUQ1A471MCL6GS	
16 (1C)	10	4×5.4	0.22	4.8	18	UUQ1C100MCL1GB
	22	5×5.4	0.22	10.56	30	UUQ1C220MCL1GB
	33	6.3×5.4	0.22	15.84	40	UUQ1C330MCL1GB
	47	6.3×5.4	0.22	22.56	50	UUQ1C470MCL1GB
	100	8×6.2	0.22	48	102	UUQ1C101MCL1GS
	100	8×10	0.22	48	210	UUQ1C101MCL6GS
	220	8×10	0.22	105.6	210	UUQ1C221MCL1GS
	220	10×10	0.22	105.6	310	UUQ1C221MCL6GS
	330	8×10	0.22	158.4	210	UUQ1C331MCL1GS
	330	10×10	0.22	158.4	310	UUQ1C331MCL6GS
	470	8×10	0.22	225.6	210	UUQ1C471MCL1GS
470	10×10	0.22	225.6	310	UUQ1C471MCL6GS	
25 (1E)	4.7	4×5.4	0.16	4	13	UUQ1E4R7MCL1GB
	10	5×5.4	0.16	7.5	23	UUQ1E100MCL1GB
	22	6.3×5.4	0.16	16.5	38	UUQ1E220MCL1GB
	33	6.3×5.4	0.16	24.75	48	UUQ1E330MCL1GB
	47	8×6.2	0.16	35.25	66	UUQ1E470MCL1GS
	100	8×10	0.16	75	155	UUQ1E101MCL1GS
	220	10×10	0.16	165	300	UUQ1E221MCL1GS





### ■ Dimensions

Rated Voltage (V) (code)	Rated Capacitance ( $\mu$ F)	Case Size $\phi$ D $\times$ L (mm)	$\tan \delta$	Leakage Current ( $\mu$ A) (at 20°C after 1 minute)	Rated Ripple (mArms) (105°C/120Hz)	Part Number
35 (1V)	4.7	4 $\times$ 5.4	0.13	4.935	15	UUQ1V4R7MCL1GB
	10	5 $\times$ 5.4	0.13	10.5	25	UUQ1V100MCL1GB
	22	6.3 $\times$ 5.4	0.13	23.1	42	UUQ1V220MCL1GB
	33	8 $\times$ 6.2	0.13	34.65	59	UUQ1V330MCL1GS
	47	8 $\times$ 10	0.13	49.35	155	UUQ1V470MCL1GS
	100	10 $\times$ 10	0.13	105	300	UUQ1V101MCL1GS
	220	10 $\times$ 10	0.13	231	300	UUQ1V221MCL1GS
50 (1H)	1	4 $\times$ 5.4	0.12	4	6.2	UUQ1H010MCL1GB
	2.2	4 $\times$ 5.4	0.12	4	11	UUQ1H2R2MCL1GB
	3.3	4 $\times$ 5.4	0.12	4.95	14	UUQ1H3R3MCL1GB
	4.7	5 $\times$ 5.4	0.12	7.05	19	UUQ1H4R7MCL1GB
	10	6.3 $\times$ 5.4	0.12	15	30	UUQ1H100MCL1GB
	22	8 $\times$ 6.2	0.12	33	51	UUQ1H220MCL1GS
	33	8 $\times$ 10	0.12	49.5	140	UUQ1H330MCL1GS
	47	8 $\times$ 10	0.12	70.5	180	UUQ1H470MCL1GS
	100	10 $\times$ 10	0.12	150	220	UUQ1H101MCL1GS

- For taping specifications, recommended land size/soldering by reflow and minimum order quantity, please refer to the Guidelines for Aluminum Electrolytic Capacitors.

## Looking for pricing, stock, or lifecycle information?

Click below to explore more details on WIN SOURCE:

-  [View UUU1C101MCL1GS on WIN SOURCE](#)
-  [Nichicon Information](#)

## Optimize Your Supply Chain with WIN SOURCE Solutions

-  Global Sourcing Solution
-  Obsolete Management
-  Cost Control Management
-  Shortage Management
-  Alternative Solution
-  Excess Inventory Management