



**THE DATASHEET OF
EVND8AA03B23**



6FE Square Trimmer Potentiometers

Type: **EVND**

■ Features

- Top-adjust or side-adjust available
- Radial taping supported
- High reliability (dustproof construction)

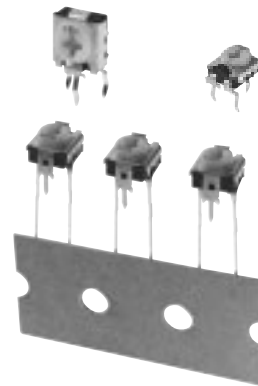

■ Recommended Applications

- Audio Visual Equipment, Home Electrical Appliances

■ Explanation of Part Numbers

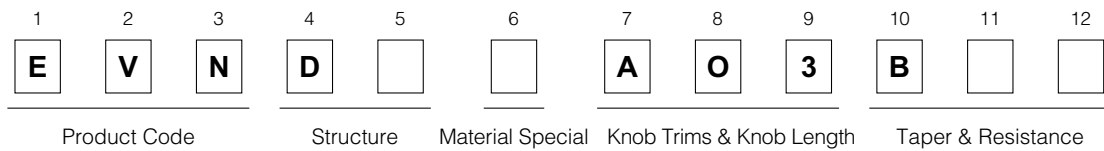

■ Specifications

Electrical Specifications	Nominal Total Resistance	1 k Ω , 2 k Ω , 5 k Ω , 10 k Ω , 20 k Ω , 50 k Ω , 100 k Ω , 200 k Ω , 500 k Ω , 1 M Ω
	Taper	B
	Rating	R \leq 500 k Ω : 0.1 W 50 V (50 °C) R>500 k Ω : 0.1 W 25 V (50 °C)
	Residual Resistance	1 k Ω \leq R \leq 2 k Ω : 60 Ω max. 2 k Ω <R \leq 1 M Ω : 3 % max., or 200 Ω max. whichever smaller
Mechanical Specifications	Rotation Angle	210 ° \pm 20 °
	Rotation Torque	2 mN·m to 25 mN·m
	Stopper Strength	Surface : 75 mN·m, reverse side : 35 mN·m
Endurance	Operating Life	100 cycles
	Resistance to Soldering Heat	240 °C to 280 °C : 5 s max., 280 °C to 300 °C : 3 s max.
	Resistance to Damp	After 350 hours : R \leq 100 k Ω +15 % -0 %, : 100 k Ω <R \leq 1 M Ω +20 % -0 %
	Endurance under Damp	After 350 hours : 1.5 h ON 0.5 h OFF : R \leq 100 k Ω \pm 15 %, : 100 k Ω <R \leq 1 M Ω \pm 20 %
	Endurance under High Temperature	70 °C \pm 3 °C After 250 hours +5 %, -15 %
Minimum Quantity/Packing Unit		EVND2A, EVND8A : 500 pcs. Polyethylene Bag (Bulk) EVNDJA, EVNDXA, EVNDCA : 1000 pcs. Radial Taping (Reel Pack)
Quantity/Carton		EVND2A, EVND8A : 5000 pcs. EVNDJA, EVNDXA, EVNDCA : 10000 pcs.

Note : R=Nominal Total Resistance

Design and specifications are each subject to change without notice. Ask factory for the current technical specifications before purchase and/or use. Should a safety concern arise regarding this product, please be sure to contact us immediately.

■ Dimensions in mm (not to scale)

● Side-adjust EVND2A

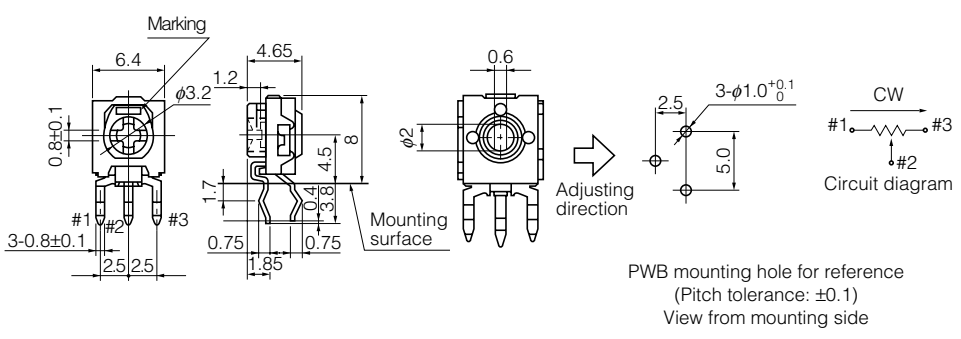

<p>No. 1</p> 	 <p style="text-align: center;">PWB mounting hole for reference (Pitch tolerance: ±0.1) View from mounting side</p> <table border="1" style="width: 100%; margin-top: 10px;"> <tr> <td>Knob color</td> <td>Orange yellow</td> </tr> </table>	Knob color	Orange yellow
Knob color	Orange yellow		

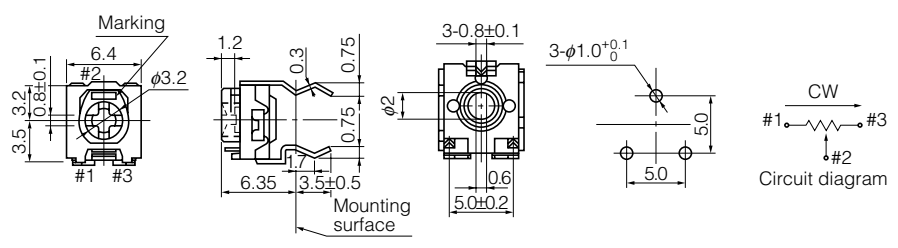
● Top-adjust EVND8A

<p>No. 2</p> 	 <p style="text-align: center;">PWB mounting hole for reference (Pitch tolerance: ±0.1) View from mounting side</p> <table border="1" style="width: 100%; margin-top: 10px;"> <tr> <td>Knob color</td> <td>Orange yellow</td> </tr> </table>	Knob color	Orange yellow
Knob color	Orange yellow		

Looking for pricing, stock, or lifecycle information?

Click below to explore more details on WIN SOURCE:

-  [View EVND8AA03B23 on WIN SOURCE](#)
-  [Panasonic Information](#)

Optimize Your Supply Chain with WIN SOURCE Solutions

-  Global Sourcing Solution
-  Obsolete Management
-  Cost Control Management
-  Shortage Management
-  Alternative Solution
-  Excess Inventory Management