



**THE DATASHEET OF  
D-602-0147**



# SPECIFICATION CONTROL DRAWING

CONTACTS, ELECTRICAL CONNECTOR, SOCKET  
 SOLDERTACT<sup>®</sup>, REMOVABLE, TWISTED PAIR, SHIELDED,  
 SIZE 12, M39029/75 TYPE  
 (FOR MIL-C-38999 SERIES I, III AND IV CONNECTORS)

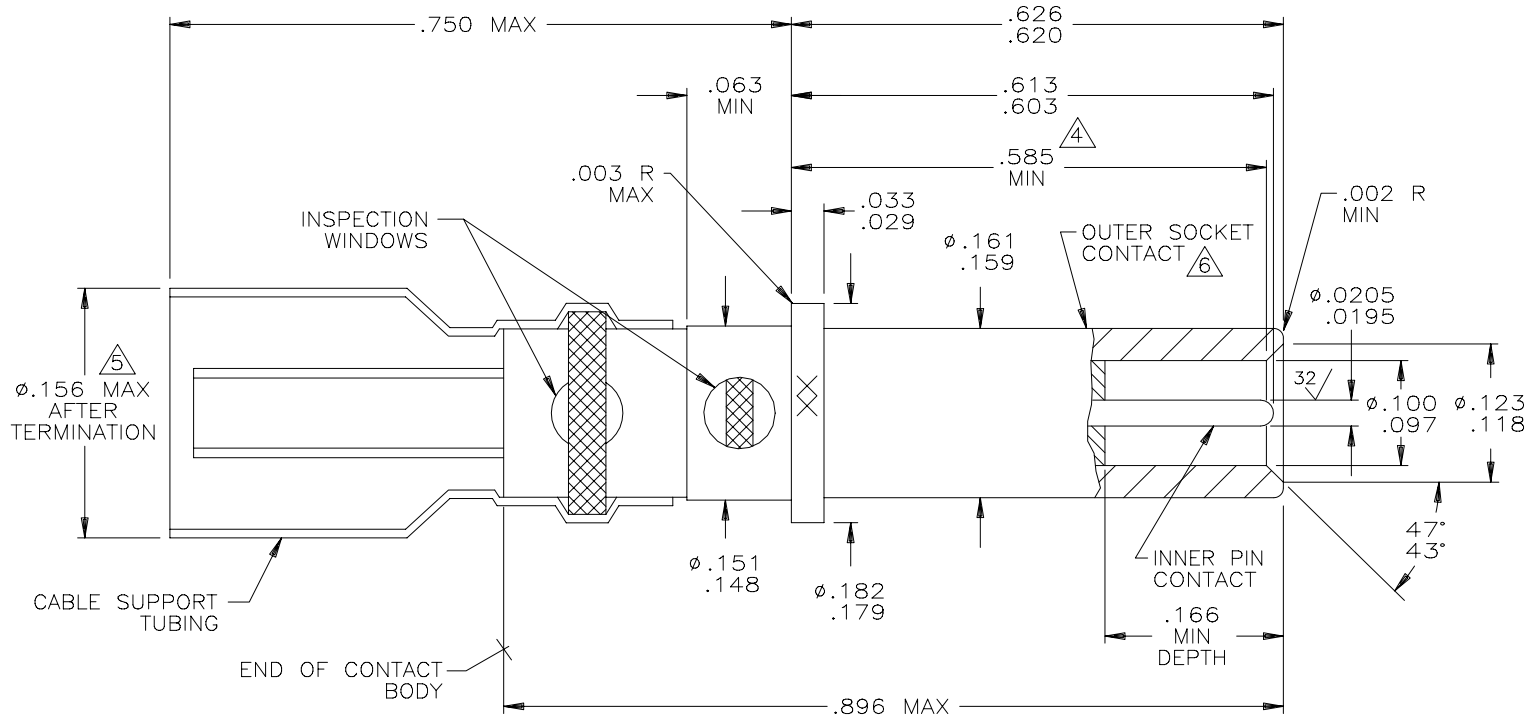

FIGURE 1.

1. DIMENSIONS ARE IN INCHES.
2. METRIC EQUIVALENTS CAN BE CALCULATED BASED UPON 1.00 INCH=25.4 m.m.
3. DIMENSIONS SHOWN APPLY AFTER PLATING.
4. POINT AT WHICH A SQUARE ENDED PIN OF THE SAME BASIC DIAMETER AS THE MATING CONTACT FIRST ENGAGES THE OUTER CONTACT SPRING. PROVISION FOR CLEARANCE HOLE SHALL BE PROVIDED.
5. SLEEVE RECOVERY: THE DIAMETER OF THE SHRINK TUBING OVER THE CABLE SHALL NOT EXCEED THE DIAMETER SHOWN.
6. MATES WITH .095/.093 DIA PIN
7. CONTACT WEIGHT: 1.441 GRAMS MAXIMUM UNTERMINATED.

NOTICE: THE INFORMATION GIVEN HEREIN IS BELIEVED TO BE RELIABLE, HOWEVER, RAYCHEM MAKES NO WARRANTIES AS TO ITS ACCURACY OR COMPLETENESS AND DISCLAIMS ANY LIABILITY IN CONNECTION WITH ITS USE. RAYCHEM'S OBLIGATIONS SHALL BE ONLY AS SET FORTH IN RAYCHEM'S STANDARD TERMS AND CONDITIONS OF SALE FOR THIS PRODUCT AND IN NO CASE WILL RAYCHEM BE LIABLE FOR ANY INCIDENTAL, INDIRECT OR CONSEQUENTIAL DAMAGES ARISING OUT OF THE SALE, RESALE, USE OR MISUSE OF THE PRODUCT.

USERS OF RAYCHEM PRODUCTS SHOULD MAKE THEIR OWN EVALUATION TO DETERMINE THE SUITABILITY OF EACH SUCH PRODUCT FOR THE SPECIFIC APPLICATION.

UNLESS OTHERWISE SPECIFIED DIMENSIONS ARE IN INCHES. METRIC DIMENSIONS ARE IN BRACKETS.

DECIMALS  
 .XXX ± [ mm]  
 .XX ± [ mm]  
 ANGLES ±

PREPARED BY: <i>TJ</i>	CAD NAME: <i>XX1463-1</i>	CHECKED: <i>ZT</i>	APPROVED: <i>CP</i> DEV MGR.	DOCUMENT NUMBER: <i>D-602-0147</i>
DATE:		DATE:	DATE:	SHEET 1 of 5

# SPECIFICATION CONTROL DRAWING

**REQUIREMENTS:**

DIMENSIONS (FIGURE 1), DESIGN CHARACTERISTICS, AND CONFIGURATION MEET THE REQUIREMENTS OF M39029/75 EXCEPT THAT THE TEMPERATURE RATING IS 125°C INSTEAD OF 200°C, TERMINATION IS BY SOLDERING INSTEAD OF CRIMPING, AND THE CABLE ACCOMODATED IS TWISTED PAIR INSTEAD OF COAXIAL. SEE TABLE I FOR CABLE ACCOMODATIONS.

THIS CONTACT IS QUALIFIED TO RAYCHEM SPECIFICATION D-6002.

MATING CONTACT: D-602-0146 (M39029/28)

TOOLS: SEE TABLE II.

TABLE I. DESIGN CHARACTERISTICS

CABLE ACCOMODATED <u>1/</u>	CONTACT CAVITY SIZE	TYPE	CLASS
TWISTED PAIR 22 AWG TWISTED PAIR 24 AWG TWISTED PAIR 26 AWG	12	D	A

1/ OTHER APPLICATIONS USING DIFFERENT CABLES MAY BE ACCOMODATED. CONSULT CONTACT MANUFACTURER FOR DETAILS.

TABLE II. TOOLS

HEATING TOOLS <u>2/</u>	REFLECTORS <u>2/</u>	STANDARD FIXTURE <u>2/</u>		REPAIR FIXTURE <u>2/</u>	INSTALLING TOOLS	REMOVAL TOOLS	FOLDING TOOL
		BASIC FIXTURE	ADAPTER				
AA-400 SUPER HEATER	#979663 MINI SOLDER SLEEVE	AD-1319 OR AD1567	AT-1319-24	AD-1566	M81969/8-09 OR M81969/14-04	M81969/8-10 OR M81969/14-04	AD-1575-1
CV-5300 MINI GUN	MG-1 SOLDERSLEEVE						

2/ SEE TERMINATION PROCEDURE: RAYCHEM ES-61218

# SPECIFICATION CONTROL DRAWING

## ASSEMBLY INSTRUCTIONS

1. STRIP CABLE AS SHOWN ON FIGURE 2.
2. INSERT CABLE INTO CONTACT UNTIL IT IS FULLY SEATED.
3. HEAT CONTACT WITH APPROPRIATE TOOLS AS SHOWN ON TABLE II UNTIL SOLDER MELTS AND FLOWS AND STRAIN RELIEF TUBING CONFORMS TO CABLE.
4. SEE TABLE I FOR CABLE ACCOMMODATION.

### TWISTED PAIR CABLE ACCOMODATION

1. SOLDERCONTACTS CONTACTS CAN BE TERMINATED TO TWISTED-PAIR CABLE OF THE FOLLOWING CONSTRUCTION

SIZE.....AWG 22 THROUGH AWG 26  
 PLATING.....TIN OR SILVER  
 CONSTRUCTION.....SOLID OR STRANDED  
 INSULATION DIAMETER.....0.055 INCH, MAXIMUM

### PREPARATION OF TWISTED PAIR CABLE

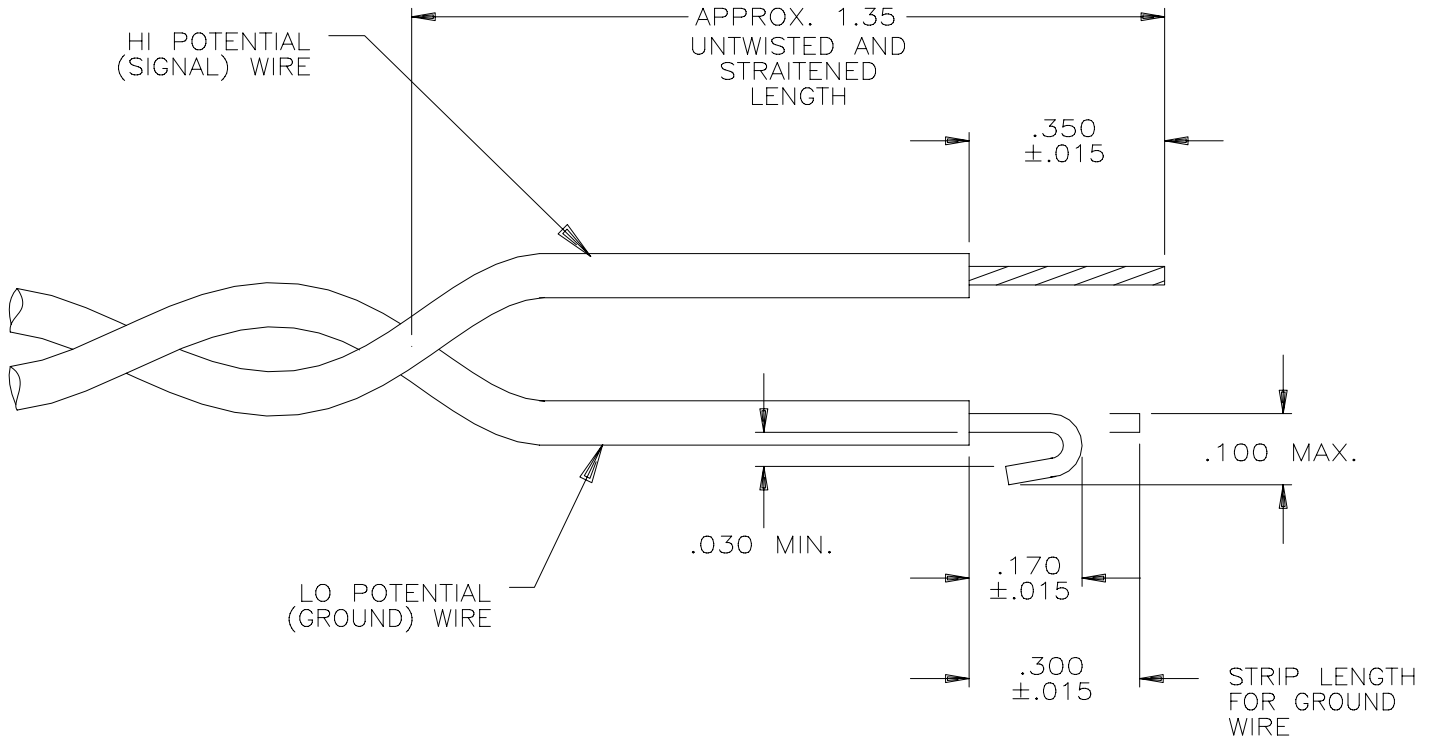

FIGURE 2

DOCUMENT NUMBER: D-602-0147	
CAD NAME: XX1463-3	SHEET 3 of 5

## SPECIFICATION CONTROL DRAWING

CONTACT ENGAGEMENT AND SEPARATION FORCES (OUTER SOCKET CONTACT ONLY): THE ENGAGEMENT DEPTH SHALL BE AS ENCOUNTERED IN NORMAL SERVICE. THE TEST PINS SHALL BE IN ACCORDANCE WITH MS3197 EXCEPT THE DIAMETERS SHALL BE AS SPECIFIED IN THE FOLLOWING, AND SURFACE ROUGHNESS SHALL NOT EXCEED 3 MICROINCHES. PROVISIONS FOR CLEARANCE HOLE SHALL BE PROVIDED.

TABLE III

TEST PIN DIAMETER (INCH)	MINIMUM SEPERATION FORCE (OUNCES)		MAXIMUM ENGAGEMENT FORCE (OUNCES)	
	INITIAL	AFTER CONDITIONING	INITIAL	AFTER CONDITIONING
.0950 $\begin{matrix} +.0002 \\ -.0000 \end{matrix}$	N/A	N/A	30.0	36.0
.0930 $\begin{matrix} +.0000 \\ -.0002 \end{matrix}$	3.0	2.5	N/A	N/A

DIELECTRIC WITHSTANDING VOLTAGE (APPLIED BETWEEN INNER AND OUTER CONTACT):  
TEST VOLTAGE:

AT SEA LEVEL:            1000 VAC. RMS.  
AT 50,000 FEET:        250 VAC. RMS.

CONTACT RESISTANCE: SEE TABLE IV.

TABLE IV. CONTACT RESISTANCE

TEST CABLE	MAXIMUM VOLTAGE DROP (MILLIVOLTS)						TEST CURRENT (AMPS)	
	$25^{\circ} \begin{matrix} +3^{\circ} \\ -0^{\circ} \end{matrix} C$		$25^{\circ} \begin{matrix} +3^{\circ} \\ -0^{\circ} \end{matrix} C$ <sub>3/</sub>		$125^{\circ} \begin{matrix} +3^{\circ} \\ -0^{\circ} \end{matrix} C$			
	CONTACT		CONTACT		CONTACT		CONTACT	
	INNER	OUTER	INNER	OUTER	INNER	OUTER	INNER	OUTER
22 AWG T.P./TC	73	73	88	88	110	110	5	5
24 AWG T.P./TC	55	55	66	66	83	83	3	3
26 AWG T.P./TC	52	52	63	63	80	80	2	2
22 AWG T.P./SHSC	73	73	88	88	110	110	5	5
24 AWG T.P./SHSC	55	55	66	66	83	83	3	3
26 AWG T.P./SHSC	52	52	63	63	80	80	2	2

3/ AFTER CONDITIONING.

TC = TIN PLATED COPPER  
TP = TWISTED PAIR WIRE  
SHSC = SILVER PLATED HIGH STRENGTH COPPER

DOCUMENT NUMBER:

D-602-0147



**Raychem**  
Products

Tyco Electronics Corporation  
305 Constitution Drive  
Menlo Park, CA 94025 U.S.A.

FSCM  
06090

REVISION:  
E

ECN#:  
T-

APPROVED:

DATE:

## SPECIFICATION CONTROL DRAWING

LOW SIGNAL LEVEL CONTACT RESISTANCE (INNER CONTACT ONLY): SEE TABLE V.

TENSILE STRENGTH (INNER AND OUTER CONTACT SOLDER JOINT): SEE TABLE V.

TABLE V. LOW SIGNAL LEVEL CONTACT RESISTANCE  
(INNER CONTACT ONLY) AND TENSILE STRENGTH

TEST CABLE	MAXIMUM CONTACT RESISTANCE (MILLIOHMS)		MINIMUM TENSILE STRENGTH (POUNDS)	
	INITIAL	AFTER CONDITIONING	INNER CONTACT	OUTER CONTACT
22 AWG T.P./TC	15	18	12	12
24 AWG T.P./TC	20	24	8	8
26 AWG T.P./TC	31	38	5	5
22 AWG T.P./SHSC	15	18	12	12
24 AWG T.P./SHSC	20	24	8	8
26 AWG T.P./SHSC	31	38	5	5

TC = TIN PLATED COPPER  
 TP = TWISTED PAIR WIRE  
 SHSC = SILVER PLATED HIGH STRENGTH COPPER

MATERIAL:	CONTACT BODY	BERYLLIUM COPPER, ALLOY 173, CONDITION H PER ASTM B196
	INNER CONTACT	BERYLLIUM COPPER, ALLOY 173, CONDITION H PER ASTM B196
	PLATING (CONTACT BODY AND INNER CONTACT)	GOLD PLATE PER MIL-G-45204 TYPE II, GRADE C 50 MICROINCHES MINIMUM OVER NICKEL PER QQ-N-290A 50 MICROINCHES MINIMUM OVER COPPER STRIKE - 40 MICROINCHES MAXIMUM
	SOLDER	Sn63 PER QQ-S-571
	FLUX	TYPE RMA PER QQ-S-571
	SHRINK TUBING	HEAT-SHRINKABLE, RADIATION-CROSSLINKED POLYVINYLIDENE FLUORIDE
	DIELECTRIC	ETFE FLUOROPOLYMER PER ASTM D3159

SHIPPING      FIGURE 1 INDICATES THE ONE-PIECE ASSEMBLY. TERMINATION INSTRUCTIONS ARE TO BE SHIPPED WITH THE UNIT PACKAGE.

DOCUMENT NUMBER: <span style="font-size: 1.2em; font-weight: bold;">D-602-0147</span>
--

## Looking for pricing, stock, or lifecycle information?

Click below to explore more details on WIN SOURCE:

 [View D-602-0147](#) on WIN SOURCE

 [TE Connectivity](#) Information

## Optimize Your Supply Chain with WIN SOURCE Solutions

-  Global Sourcing Solution
-  Obsolete Management
-  Cost Control Management
-  Shortage Management
-  Alternative Solution
-  Excess Inventory Management