

WIN**SOURCE**
ELECTRONICS

THE DATASHEET OF
66098-9



66098-9 ✓ ACTIVE

AMP | AMP Type III+, Circular Plastic Connectors Series 1

TE Internal #: 66098-9

Pin Contact, Precious Metal, Locking Spring Contact Retention,
Size 16 Contact Size, Discrete Wire, 18 – 16 AWG, .8 – 1.4 mm²
Wire, AMP Type III+

[View on TE.com >](#)



Connectors > Contacts > Connector Contacts



Contact Type: **Pin**

Contact Mating Area Plating Material: **Precious Metal**

Wire Contact Termination Area Plating Material: **Tin**

Contact Retention Within Housing: **With**

Contact Retention Type Within Housing: **Locking Spring**

Features

Product Type Features

Discrete Wire Type	Solid or Stranded
Sealable	No

Configuration Features

Compatible With Wire & Cable Type	Discrete Wire
-----------------------------------	---------------

Contact Features

Contact Underplating Material	Nickel
Contact Orientation	Straight
Mating Pin Diameter	1.57 mm[.062 in]
Contact Underplating Material Thickness	1.27 µm[50 µin]
Contact Mating Area Plating Material Thickness	.76 µm[30 µin]
Wire Contact Termination Area Plating Material Finish	Bright
Contact Shape & Form	Round
Contact Length	27.1 mm[1.067 in]
Contact Mating Area Length	9.91 mm[.39 in]



Wire Contact Termination Area Plating Thickness	1.27 µm[50 µin]
Barrel Type	Open
Contact Type	Pin
Contact Mating Area Plating Material	Precious Metal
Wire Contact Termination Area Plating Material	Tin
Contact Retention Within Housing	With
Contact Size	Size 16
Contact Base Material	Brass
Contact Current Rating (Max)	13 A

Termination Features

Termination Method to Wire & Cable	Crimp
Product Terminates To	Wire & Cable

Mechanical Attachment

Wire Insulation Support	With
Contact Retention Type Within Housing	Locking Spring

Dimensions

Compatible Insulation Diameter Range	2.03 – 2.54 mm[.08 – .1 in]
Wire Size	.8 – 1.4 mm ²

Usage Conditions

Operating Temperature Range	-55 – 150 °C[-67 – 302 °F]
-----------------------------	----------------------------

Operation/Application

Circuit Application	Power & Signal
---------------------	----------------

Packaging Features

Packaging Quantity	4000
Packaging Method	Reel

Product Compliance

[For compliance documentation, visit the product page on TE.com>](#)

EU RoHS Directive 2011/65/EU	Compliant
EU ELV Directive 2000/53/EC	Compliant
China RoHS 2 Directive MIIT Order No 32, 2016	No Restricted Materials Above Threshold
EU REACH Regulation (EC) No. 1907/2006	



Current ECHA Candidate List: JAN 2025 (247)
 Candidate List Declared Against: JUNE 2024 (241)
 Does not contain REACH SVHC

Halogen Content Not Low Halogen - contains Br or Cl > 900 ppm.

Solder Process Capability Not applicable for solder process capability

Product Compliance Disclaimer

This information is provided based on reasonable inquiry of our suppliers and represents our current actual knowledge based on the information they provided. This information is subject to change. The part numbers that TE has identified as EU RoHS compliant have a maximum concentration of 0.1% by weight in homogenous materials for lead, hexavalent chromium, mercury, PBB, PBDE, DBP, BBP, DEHP, DIBP, and 0.01% for cadmium, or qualify for an exemption to these limits as defined in the Annexes of Directive 2011/65/EU (RoHS2). Finished electrical and electronic equipment products will be CE marked as required by Directive 2011/65/EU. Components may not be CE marked. Additionally, the part numbers that TE has identified as EU ELV compliant have a maximum concentration of 0.1% by weight in homogenous materials for lead, hexavalent chromium, and mercury, and 0.01% for cadmium, or qualify for an exemption to these limits as defined in the Annexes of Directive 2000/53/EC (ELV). Regarding the REACH Regulation, the information TE provides on SVHC in articles for this part number is based on the latest European Chemicals Agency (ECHA) 'Guidance on requirements for substances in articles' posted at this URL: <https://echa.europa.eu/guidance-documents/guidance-on-reach>

Compatible Parts



TE Part # 2151023-1
[OCEAN_2.0_Applicator-S-080F1200-RSM](#)



TE Part # 208470-1
[CMC PLUG ASSEMBLY,SZ 28](#)



TE Part # 796094-2
[SLD CPC PLUG ASY,11-4,STD SEX](#)

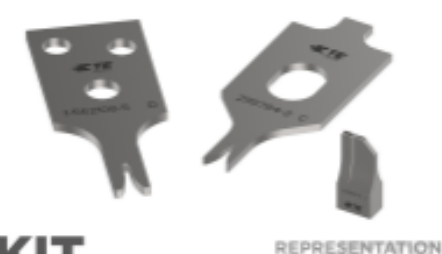

TE Part # 7-2151023-7
[OCEAN_2.0_SPARE_PART_KIT-080F1200](#)



TE Part # 211768-1
[CPC PLUG ASSEMBLY SIZE 17-9](#)



TE Part # 208457-1
[CMC PLUG ASSEMBLY,SZ 28-24](#)



TE Part # 788157-2
[SLD CPC PLUG ASSY,13-9,STD SEX](#)



TE Part # 213850-1
[CPC PLUG ASSEMBLY SIZE 23-37](#)



TE Part # 213848-1
CPC PLUG ASSEMBLY SIZE 23-37



TE Part # 211400-1
CPC PLUG ASSEMBLY SIZE 13-7



TE Part # 206150-1
CPC PLUG ASSEMBLY SIZE 23-37



TE Part # 206044-1
CPC PLUG ASSEMBLY SIZE 17-14



TE Part # 206708-1
CPC PLUG ASSEMBLY SIZE 13-9



TE Part # 91505-1
CCII TYPE III+ 24-16 ASSY



TE Part # 208718-1
CMC PLUG ASSEMBLY, SZ 14-5



TE Part # 213974-1
METRIMATE 30P RCPT HOUSING



TE Part # 206837-1
CPC PLUG ASSEMBLY SIZE 23-24



TE Part # 206429-1
CPC PLUG ASSY, 11-4, REV SEX



TE Part # 58495-1
PRO CRIMPER ASSY MULTIMATE



KIT
REPRESENTATION ONLY

TE Part # 7-2266601-7
OC-080F120O-752-CRIMPTOOLINGKIT

Also in the Series | **AMP Type III+**



Connector Contacts(260)



Insertion & Extraction Tools(4)



Power Contacts(260)

Also in the Series | **Circular Plastic Connectors Series 1**



Circular Power Connectors(211)



Connector Contacts(260)



Power Contacts(260)

Customers Also Bought



TE Part #207893-1
CONTACT PIN ASSY.



TE Part #323030
SPLICE,SOLIS PARA HR 22-16



TE Part #2-320861-1
TERMINAL,PIDG SPD FLG 16-14 6



TE Part #3-1879071-1
THS50 33R 5%



TE Part #207896-1
CONTACT SOC. ASSY.



TE Part #EC7552-000
HL104WE1TS025B

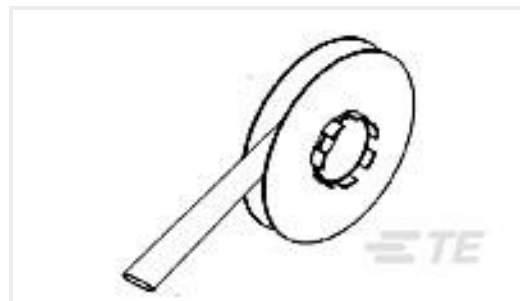

TE Part #CP3367-000
TTMS-MP-3.2-9

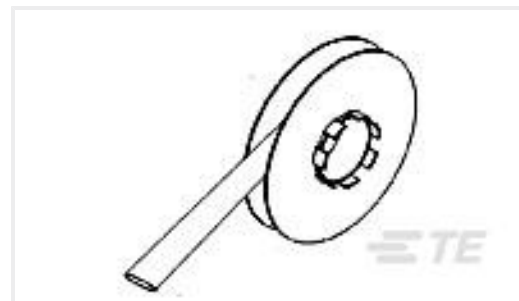

TE Part #CM6264-000
TTMS-MP-12.7-9



TE Part #CAT-M9194-CH8172
MULTILOCK, CONNECTOR HOUSING

Documents

Product Drawings

III+ PIN,18-16,30AU/FL,STRIP

English

CAD Files

Customer View Model

[ENG_CVM_66098-9_AE.3d_igs.zip](#)

English

Customer View Model



[ENG_CVM_66098-9_AE.3d_stp.zip](#)

English

Customer View Model

[ENG_CVM_66098-9_AE.2d_dxf.zip](#)

English

3D PDF

English

3D PDF

3D

Customer View Model

[ENG_CVM_CVM_66098-9_AP.2d_dxf.zip](#)

English

Customer View Model

[ENG_CVM_CVM_66098-9_AP.3d_igs.zip](#)

English

Customer View Model

[ENG_CVM_CVM_66098-9_AP.3d_stp.zip](#)

English

By downloading the CAD file I accept and agree to the [Terms and Conditions](#) of use.

Datasheets & Catalog Pages

[AMP Circular Connectors for Commercial Signal & Power Applications](#)

English

[Signal Contacts](#)

English

[M_SERIES_PIN_AND_SOCKET_CONNECTORS](#)

English

Product Specifications

[Application Specification](#)

English

Instruction Sheets

[Instruction Sheet \(U.S.\)](#)

Japanese

[Instruction Sheet \(U.S.\)](#)

English

Looking for pricing, stock, or lifecycle information?

Click below to explore more details on WIN SOURCE:

[View 66098-9 on WIN SOURCE](#)

[TE Connectivity Information](#)

Optimize Your Supply Chain with WIN SOURCE Solutions

- ✓ Global Sourcing Solution
- ✓ Obsolete Management
- ✓ Cost Control Management
- ✓ Shortage Management
- ✓ Alternative Solution
- ✓ Excess Inventory Management