

SJ021507-E

DWG. NO.

SYM	DCN NO.	DESCRIPTION	DATE	DRAWN	CHECKED	APP' D	APP' D

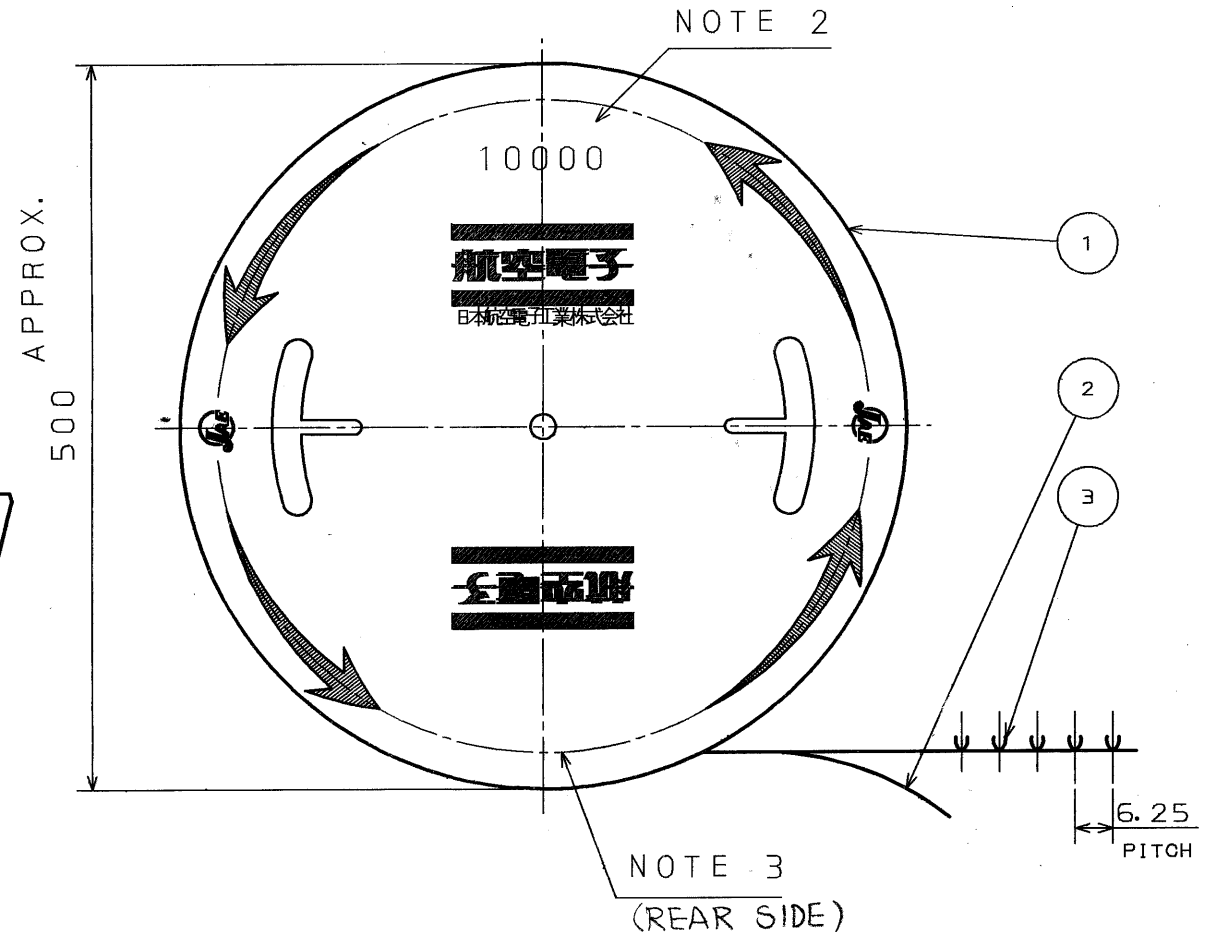
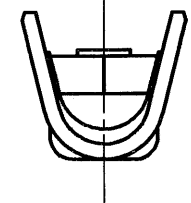
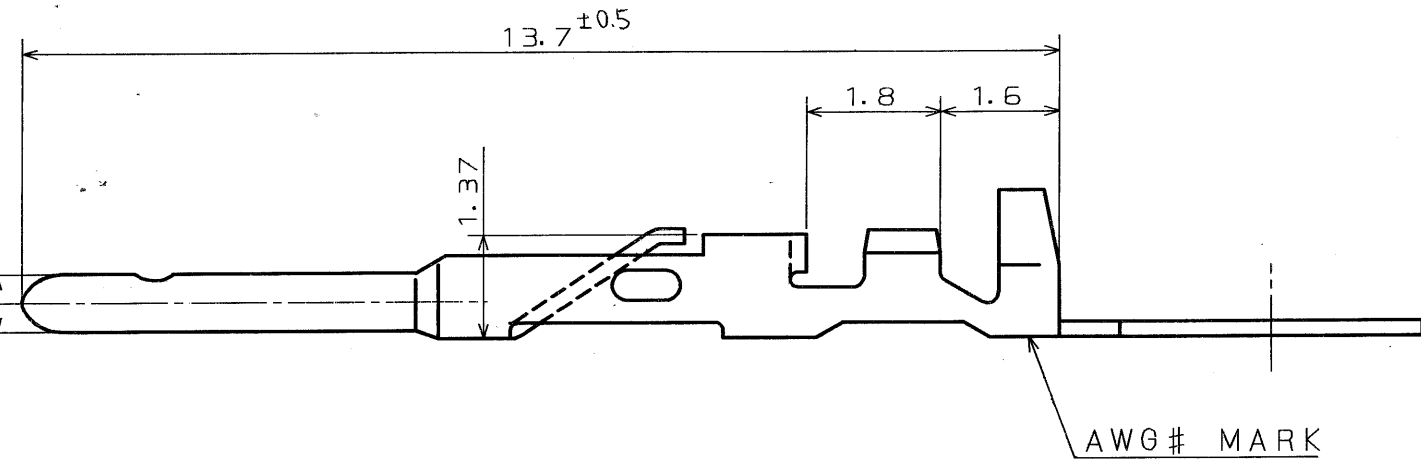
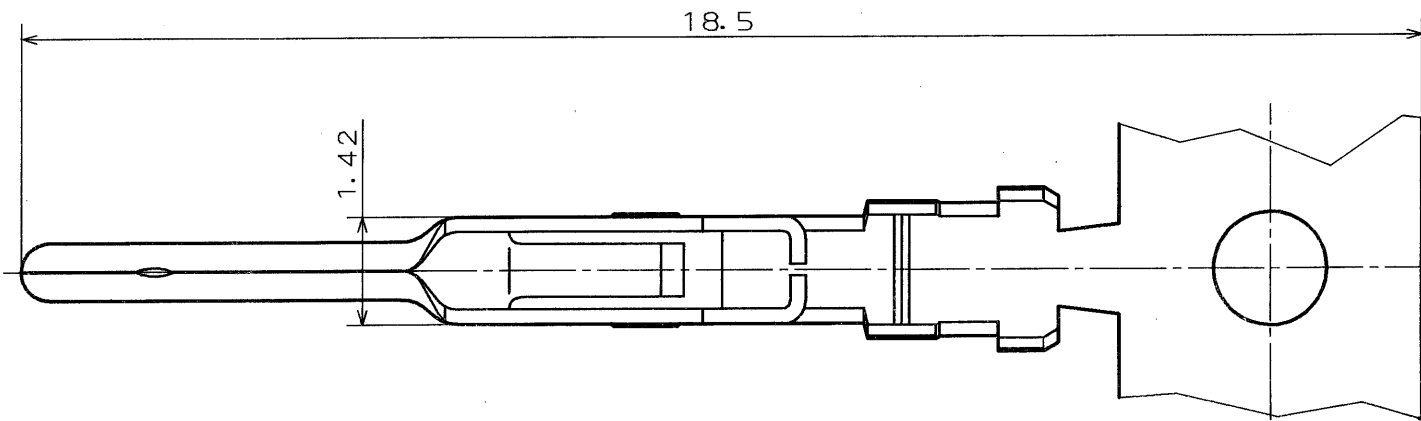

DESCRIPTION	APPLICABLE WIRE		AWG# MARK
	WIRE SIZE	OUTER DIA. OF INSUL.	
D02-22-22P-10000	AWG#22~24	DIA 1.3 MAX.	22
D02-22-26P-10000	AWG#26~28	DIA 1.1 MAX.	26

- NOTE 1. CONTACT TO BE SUPPLIED IN REELED FORM.
(10,000 CONTACT/REEL)
2. NUMBER OF CONTACTS TO BE SHOWN ON THIS PORTION.
3. LABEL SHOWING PART NUMBER & Q'TY TO BE PUT ON THIS PORTION.

ITEM	DESCRIPTION	Q'TY	MATERIAL	FINISH	REMARKS
3	PIN CONTACT	10000	COPPER ALLOY	GOLD OVER NICKEL	
2	PAPER TAPE	1	PAPER		
1	MAGAZINE	1	PAPER		

REFERENCE DOCUMENT JACS-3050-2	DATE 9 JUN. '87	SCALE 10/1	QTY 10000	FINISH GOLD OVER NICKEL	REMARKS
MATERIAL	DRAWN E. MURANO	TITLE D02-22-22P-10000 D02-22-26P-10000			
TREATMENT	CHECKED Y. HAYASHI				
FINISH	APP' D <i>K. Takeuchi</i>				
	APP' D <i>S. Iwashimoto</i>	SERIES			

DIMENSIONS ARE IN MILLIMETERS
TOLERANCES ON: (INCHES)

DIMENSION	ANGLES
. ± 0.3	X° ±
.X ± 0.3	X'X' ±
.XX ±	CONCENTRICITY
.XXX ±	WITHIN T. I. R.

JAE-CONNECTOR
Reference Only

NAKAGAMI-CHO, AKISHIMA-SHI
TOKYO, JAPAN

DWG. NO.
SJ021507-E

DOCF-116A

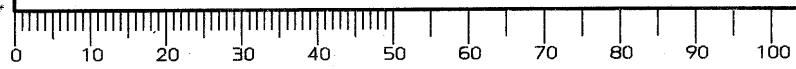

CSP-5150
SIZE A3

Looking for pricing, stock, or lifecycle information?

Click below to explore more details on WIN SOURCE:

- [View D02-22-26P-10000 on WIN SOURCE](#)
- [JAE Electronics Information](#)

Optimize Your Supply Chain with WIN SOURCE Solutions

- ✓ Global Sourcing Solution
- ✓ Obsolete Management
- ✓ Cost Control Management
- ✓ Shortage Management
- ✓ Alternative Solution
- ✓ Excess Inventory Management