



**THE DATASHEET OF
SMRR7010C-1E**



SMR·SMRR^{7000C}_{8000C}

Washable

Hyper-Miniature Dip Rotary Switches(7.5mm sq.) 〔Surface Mount〕

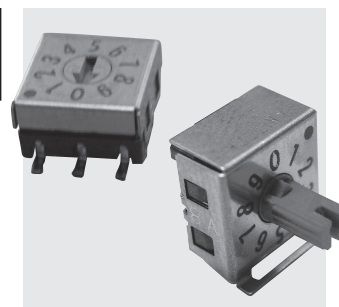

RoHS Compliant

■ Features

1. **Hyper-miniature Size(7.5mm sq.)**
Designed for high density mounting.
2. **Process Sealed**
3. **Gold Plated Contacts**
4. **Clearly Visible Legends and Position Indicator**

■ Specifications

Rating	Switching	Max.	30mA 15VDC
		Min.	1μA 20mVDC
	Non-switching		100mA 50VDC
Contact resistance		100mΩ maximum	
Dielectric strength		250VAC, 60s	
Insulation resistance		1,000MΩ minimum(100VDC)	
Load life		20,000 steps 30mA 15VDC	
Operating torque		49mN·m [500gf·cm] maximum	
Operating temperature range		-25~+85°C	
Storage temperature range		-40~+85°C	

■ Part Numbering

SMR **R** **7** **0** **10** **C** **-** **1E**
 Series code Terminals Actuators Circuits Number of positions Structure Packaging spec

None	Gull Wing	7	Screwdriver Actuator	0	Real code	10	10 positions	1	Stick-Tube
R	Right angle	8	Shaft Actuator	1	Complementary code	16	16 positions	1E	Taping

■ Table of Part Numbers

Circuit function	Positions	Actuators	Screwdriver Actuator		Shaft Actuator	
		Terminals	Gull Wing	Right Angle	Gull Wing	Right Angle
Real code	10		SMR7010C-1 SMR7010C-1E	SMRR7010C-1 SMRR7010C-1E	★ SMR8010C-1	★ SMRR8010C-1 ★ SMRR8010C-1E
	16		SMR7016C-1 SMR7016C-1E	SMRR7016C-1 SMRR7016C-1E	SMR8016C-1	★ SMRR8016C-1 ★ SMRR8016C-1E
Complementary code	10		SMR7110C-1 SMR7110C-1E	SMRR7110C-1 SMRR7110C-1E	SMR8110C-1	★ SMRR8110C-1 ★ SMRR8110C-1E
	16		SMR7116C-1 SMR7116C-1E	SMRR7116C-1 SMRR7116C-1E	★ SMR8116C-1	★ SMRR8116C-1 ★ SMRR8116C-1E

★ : Made-to-order products.

SMR7010C-1(E)
SMR7110C-1(E)



(Gull Wing)

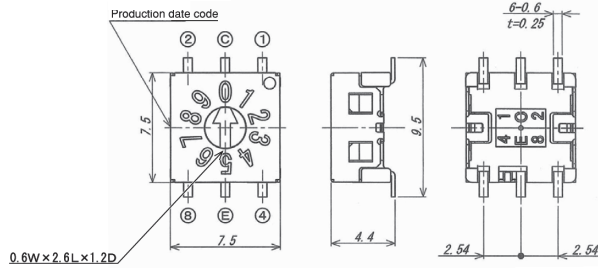

Terminal numbers are shown on the bottom of the switch.

● Real code

Actuator color : Yellow

Part No.	Position	Terminal #			
		1	2	4	8
SMR7010C-1(E) SMRR7010C-1(E)	0				
	1	●			
	2		●		
	3	●	●		
	4			●	
	5	●		●	
	6		●	●	
	7	●	●	●	
	8				●
9	●			●	

● Complementary code

Actuator color : Red

Part No.	Position	Terminal #			
		1	2	4	8
SMR7110C-1(E) SMRR7110C-1(E)	0	●	●	●	●
	1		●	●	●
	2	●		●	●
	3			●	●
	4	●	●		●
	5		●		●
	6	●			●
	7				●
	8	●	●	●	
9		●	●		

SMRR7010C-1(E)
SMRR7110C-1(E)



(Right Angle)

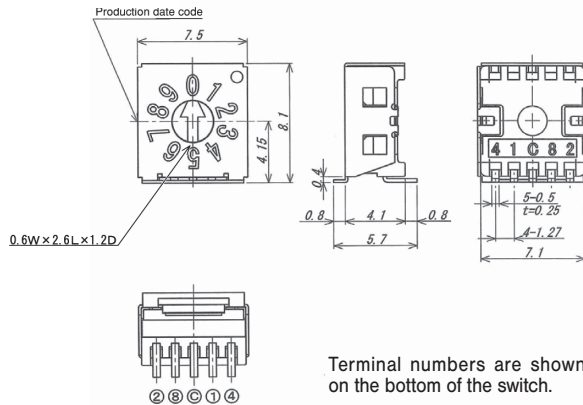

Terminal numbers are shown on the bottom of the switch.

● Real code

Actuator color : Yellow

Part No.	Position	Terminal #			
		1	2	4	8
SMR7016C-1(E) SMRR7016C-1(E)	0				
	1	●			
	2		●		
	3	●	●		
	4			●	
	5	●		●	
	6		●	●	
	7	●	●	●	
	8				●
	9	●			●
	A		●		●
	B	●	●		●
	C			●	●
	D	●		●	●
	E		●	●	●
F	●	●	●	●	

● Complementary code

Actuator color: Red

Part No.	Position	Terminal #			
		1	2	4	8
SMR7116C-1(E) SMRR7116C-1(E)	0	●	●	●	●
	1		●	●	●
	2	●		●	●
	3			●	●
	4	●	●		●
	5		●		●
	6	●			●
	7				●
	8	●	●	●	
	9		●	●	
	A	●		●	
	B			●	
	C	●	●		
	D		●		
	E	●			
F					

SMR7016C-1(E)
SMR7116C-1(E)



(Gull Wing)

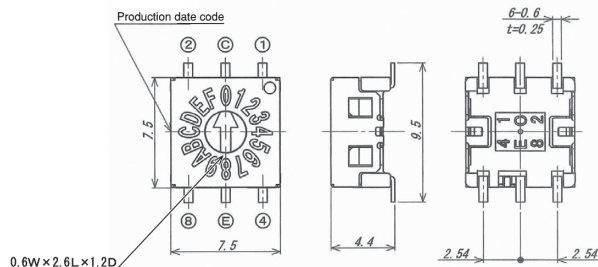

Terminal numbers are shown on the bottom of the switch.

SMRR7016C-1(E)
SMRR7116C-1(E)



(Right Angle)

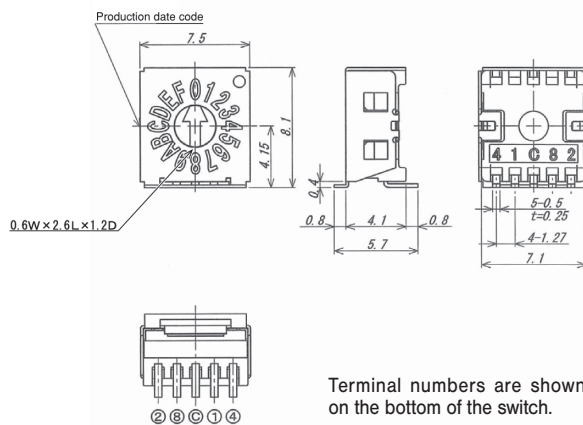

Terminal numbers are shown on the bottom of the switch.

SMR8010C-1
SMR8110C-1

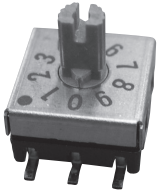

(Gull Wing)

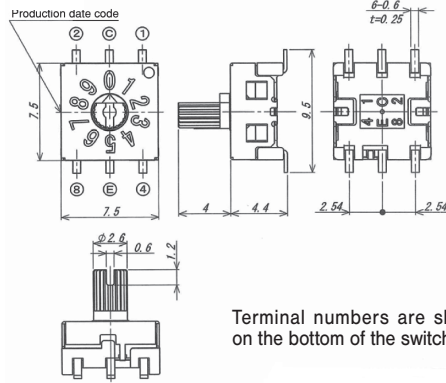

● Real code

Actuator color : Yellow

Part No.	Position	Terminal #			
		1	2	4	8
SMR8010C-1 SMRR8010C-1(E)	0				
	1	●			
	2		●		
	3	●	●		
	4			●	
	5	●		●	
	6		●	●	
	7	●	●	●	
	8				●
9	●			●	

● Complementary code

Actuator color : Red

Part No.	Position	Terminal #			
		1	2	4	8
SMR8110C-1 SMRR8110C-1(E)	0	●	●	●	●
	1		●	●	●
	2	●		●	●
	3			●	●
	4	●	●		●
	5		●		●
	6	●			●
	7				●
	8	●	●	●	
9		●	●		

SMRR8010C-1(E)
SMRR8110C-1(E)



(Right Angle)

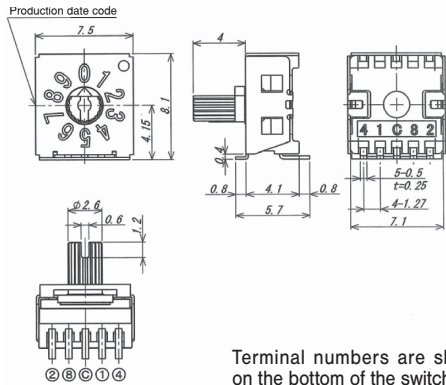

● Real code

Actuator color : Yellow

Part No.	Position	Terminal #			
		1	2	4	8
SMR8016C-1 SMRR8016C-1(E)	0				
	1	●			
	2		●		
	3	●	●		
	4			●	
	5	●		●	
	6		●	●	
	7	●	●	●	
	8				●
	9	●			●
	A		●	●	●
	B	●	●		●
	C			●	●
	D	●		●	●
	E		●	●	●
	F	●	●	●	●

● Complementary code

Actuator color : Red

Part No.	Position	Terminal #			
		1	2	4	8
SMR8116C-1 SMRR8116C-1(E)	0	●	●	●	●
	1		●	●	●
	2	●		●	●
	3			●	●
	4	●	●		●
	5		●		●
	6	●			●
	7				●
	8	●	●	●	
	9		●	●	
	A	●		●	
	B			●	
	C	●	●		
	D		●		
	E	●			
	F				

SMR8016C-1
SMR8116C-1

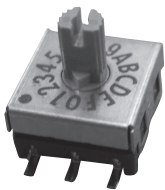

(Gull Wing)

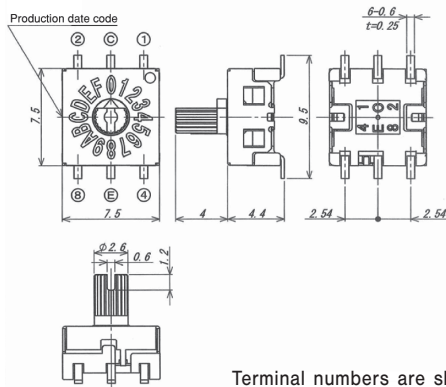

SMRR8016C-1(E)
SMRR8116C-1(E)

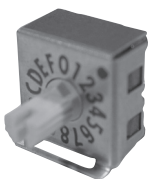

(Right Angle)

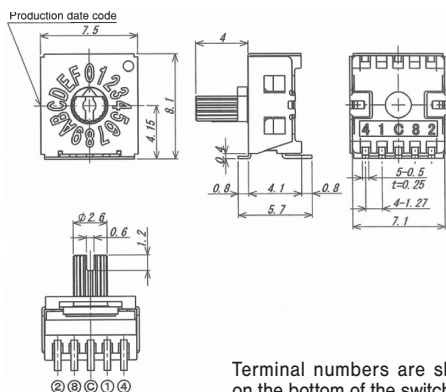

PCB Footprints

(Top view)

Terminal style	Gull Wing	Right Angle
Footprint dimensions		

Soldering Specifications

- (1) Manual Soldering
350°C, 3 sec. Max.
- (2) Reflow
Peak temperature 255°C (Please refer to the profile below.)

Flux Cleaning

After soldering, wait until the switches cool down to room temperature (30°C or below) before washing. If the switches are cleaned while still above 30°C, a vacuum will occur which will cause the cleaning solution to be sucked into the switches.

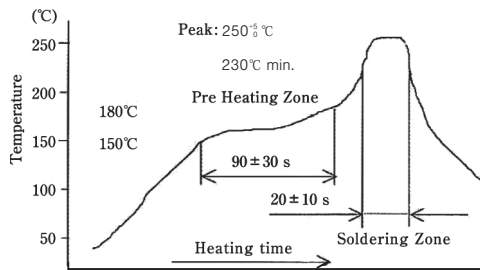

Reflow soldering: 2 times max.

Packaging Specifications

Series	SMR7000C-1E	SMRR7000C-1E/8000C-1E
Taping	<p>1,000 pcs/reel</p>	<p>500 pcs/reel</p>
Stick-Tube	<p>SMR7000C-1/8000C-1</p> <p>50 pcs/stick</p> <p>$Q = 435 \pm 1$</p>	

- Taping quantity: SMR series 1,000pcs / reel, SMRR series 500pcs/reel.
Each reel is packed in a cardboard box.
- Minimum packaging quantity: Stick-Tube 50pcs, Taping 500pcs or 1,000pcs (refer to Packaging Specifications)

Looking for pricing, stock, or lifecycle information?

Click below to explore more details on WIN SOURCE:

- ⊖ [View SMRR7010C-1E on WIN SOURCE](#)
- ⊖ [Nidec Copal Electronics Information](#)

Optimize Your Supply Chain with WIN SOURCE Solutions

- ✓ Global Sourcing Solution
- ✓ Obsolete Management
- ✓ Cost Control Management
- ✓ Shortage Management
- ✓ Alternative Solution
- ✓ Excess Inventory Management