



**THE DATASHEET OF
TJA1044BTK/0J**



TJA1044

High-speed CAN transceiver with Standby mode

Rev. 8.0 — 6 November 2024

Product data sheet



1 General description

The TJA1044 is part of the Mantis family of high-speed CAN transceivers. It provides an interface between a Controller Area Network (CAN) protocol controller and the physical two-wire CAN bus. The transceiver is designed for high-speed CAN applications in the automotive industry, providing the differential transmit and receive capability to (a microcontroller with) a CAN protocol controller.

The TJA1044 offers a feature set optimized for 12 V automotive applications, with significant improvements over NXP's first- and second-generation CAN transceivers, such as the TJA1040 and TJA1042, and excellent electromagnetic compatibility (EMC) performance. Additionally, the TJA1044 features:

- Ideal passive behavior to the CAN bus when the supply voltage is off
- A very low-current Standby mode with bus wake-up capability
- Excellent EMC performance, even without a common mode choke
- Variants with a V_{IO} pin can be interfaced directly with microcontrollers with supply voltages from 3.3 V to 5 V

These features make the TJA1044 an excellent choice for all types of HS-CAN, in nodes that require a low-power mode with wake-up capability via the CAN bus.

The TJA1044 implements the CAN physical layer as defined in ISO 11898-2:2024 third edition and SAE J2284-1 to SAE J2284-5. The TJA1044T is specified for data rates up to 1 Mbit/s. Additional timing parameters defining loop delay symmetry are specified for the other variants. This implementation enables reliable communication in the CAN FD fast phase at data rates up to 5 Mbit/s. The TJA1044B and TJA1044C feature shorter propagation delay, supporting larger network topologies.

2 Features and benefits

2.1 General

- Fully ISO 11898-2:2024, SAE J2284-1 to SAE J2284-5 and SAE J1939-14 compliant¹
- Very low-current Standby mode with local and bus wake-up capability
- Optimized for use in 12 V automotive systems
- Low electromagnetic emissions and high electromagnetic immunity, according to proposed EMC standards IEC-TS62228 and SAE J2962-2:2019²
- AEC-Q100 qualified
- Dark green product (halogen free and Restriction of Hazardous Substances (RoHS) compliant)

¹ Compliant with the exception of parameters $V_{CM}(STEP)$ and $V_{CM}(PP)$; intended as an indication of emission performance. Note that the device fulfills the EMC requirements, as evidenced through IBEE reports available on request.

² Verified by an external test house for TJA1044B/C.



- Variants with a V_{IO} pin allow for direct interfacing with 3.3 V to 5 V microcontrollers. Variants without a V_{IO} pin can interface with 3.3 V (except TJA1044C) and 5 V-supplied microcontrollers, provided the microcontroller I/Os are 5 V tolerant.
- Shorter propagation delay on the TJA1044B and TJA1044C variants supports larger network topologies (see [Table 8](#))
- Both V_{IO} and non- V_{IO} variants are available in SO8 and leadless HVSON8 (3.0 mm × 3.0 mm) packages; HVSON8 with improved Automated Optical Inspection (AOI) capability.

2.2 Predictable and fail-safe behavior

- Functional behavior predictable under all supply conditions
- Transceiver disengages from the bus (high-ohmic) when the supply voltage drops below the switch-off undervoltage threshold
- Transmit Data (TXD) dominant time-out functions
- Internal biasing of TXD and STB input pins

2.3 Low-power management

- Very low-current Standby mode with host and bus wake-up capability
- Variants with V_{IO} pin: CAN wake-up receiver powered by V_{IO} allowing V_{CC} to be shut down
- Variants with V_{IO} pin and TJA1044C: CAN wake-up pattern filter time of 0.5 μ s to 1.8 μ s, meeting Classical CAN and CAN FD requirements

2.4 Protection

- High ESD handling capability on the bus pins (8 kV IEC and HBM)
- Bus pins protected against transients in automotive environments
- Undervoltage detection on pins V_{CC} and V_{IO}
- Thermally protected

2.5 TJA1044 CAN FD (applicable to all product variants except TJA1044T)

- Timing guaranteed for CAN FD data rates up to 5 Mbit/s

3 Quick reference data

Table 1. Quick reference data

Symbol	Parameter	Conditions	Min	Typ	Max	Unit
V _{CC}	supply voltage		4.5	-	5.5	V
I _{CC}	supply current	Standby mode				
		TJA1044T, GT, GTK	-	10	15	μA
		TJA1044C	-	10	17.5	μA
		variants with a V _{IO} pin	-	0.1	1	μA
		Normal mode				
		bus recessive	2	5	10	mA
	bus dominant	20	45	60	mA	
V _{uvd(stb)(VCC)}	standby undervoltage detection voltage on pin V _{CC}		3.5	4	4.3	V
V _{uvd(swoff)(VCC)}	switch-off undervoltage detection voltage on pin V _{CC}	TJA1044T, GT, GTK	1.3	2.4	3.4	V
		TJA1044C	2.4	2.6	2.8	V
V _{IO}	supply voltage on pin V _{IO}		2.91	-	5.5	V
I _{IO}	supply current on pin V _{IO}	Standby mode	-	10	16.5	μA
		Normal mode; bus recessive	10	17	30	μA
		Normal mode; bus dominant	-	170	300	μA
V _{uvd(swoff)(VIO)}	switch-off undervoltage detection voltage on pin V _{IO}	variants with a V _{IO} pin	2.4	2.6	2.8	V
V _{ESD}	electrostatic discharge voltage	IEC 61000-4-2 at pins CANH and CANL	-8	-	+8	kV
V _{CANH}	voltage on pin CANH	limiting value according to IEC60134	-42	-	+42	V
V _{CANL}	voltage on pin CANL	limiting value according to IEC60134	-42	-	+42	V
T _{vj}	virtual junction temperature		-40	-	+150	°C

4 Ordering information

Table 2. Ordering information

Type number ^[1]	Package		
	Name	Description	Version
TJA1044T TJA1044BT TJA1044CT TJA1044GT TJA1044GT/3	SO8	plastic small outline package; 8 leads; body width 3.9 mm	SOT96-1
TJA1044BTK TJA1044CTK TJA1044GTK TJA1044GTK/3	HVSON8	plastic thermal enhanced very thin small outline package; no leads; 8 terminals; body 3 × 3 × 0.85 mm	SOT782-1

[1] TJA1044BT(K) and TJA1044GT(K)/3 with V_{IO} pin; all variants other than TJA1044T support CAN FD.

5 Block diagram

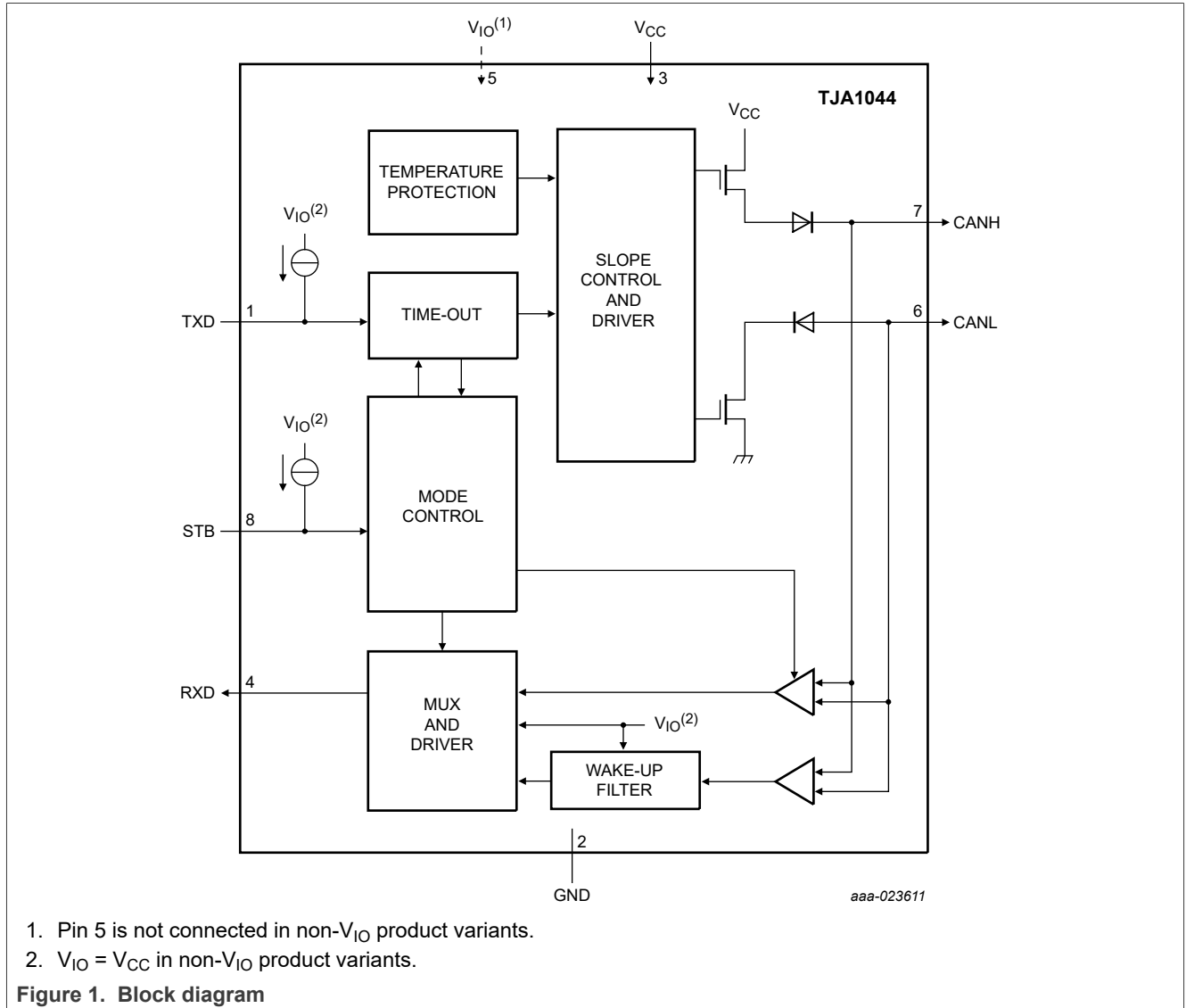

6 Pinning information

6.1 Pinning

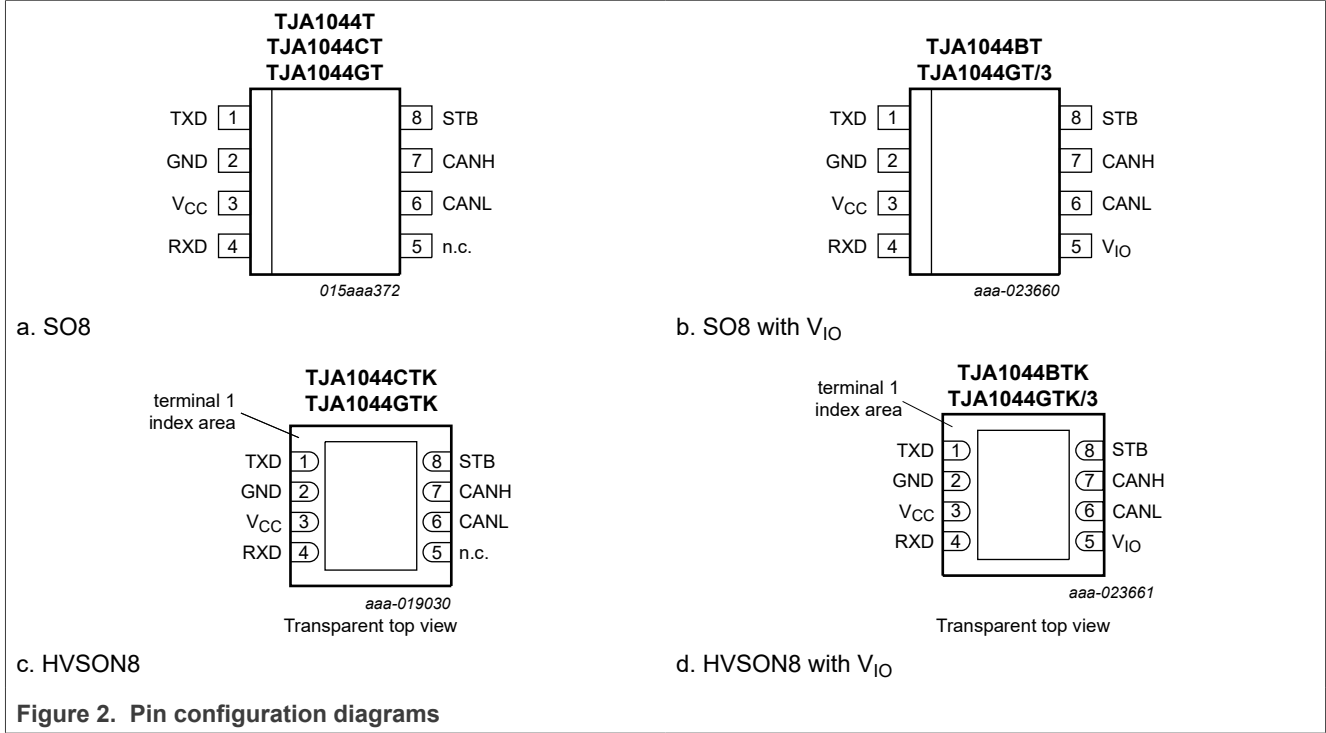

6.2 Pin description

Table 3. Pin description

Symbol	Pin	Type ^[1]	Description
TXD	1	I	transmit data input
GND ^[2]	2	G	ground supply
V _{CC}	3	P	supply voltage
RXD	4	O	receive data output; reads out data from the bus lines
n.c.	5	-	not connected; TJA1044T, TJA1044CT(K) and TJA1044GT(K) variants
V _{IO}	5	P	supply voltage for I/O level adapter; TJA1044BT(K) and TJA1044GT(K)/3 variants
CANL	6	AIO	LOW-level CAN bus line
CANH	7	AIO	HIGH-level CAN bus line
STB	8	I	Standby mode control input

[1] I: digital input; O: digital output; AIO: analog input/output; P: power supply; G: ground.

[2] HVSON8 package die supply ground is connected to both the GND pin and the exposed center pad. The GND pin must be soldered to board ground. For enhanced thermal and electrical performance, it is recommended that the exposed center pad also be soldered to board ground.

7 Functional description

7.1 Operating modes

The TJA1044 supports two operating modes, Normal and Standby. The operating mode is selected via pin STB. See [Table 4](#) for a description of the operating modes under normal supply conditions.

Table 4. Operating modes

Mode	Inputs		Outputs	
	Pin STB	Pin TXD	CAN driver	Pin RXD
Normal	LOW	LOW	dominant	LOW
		HIGH	recessive	LOW when bus dominant HIGH when bus recessive
Standby	HIGH	x ^[1]	biased to ground	follows BUS when wake-up detected HIGH when no wake-up detected

[1] 'x' = don't care.

7.1.1 Normal mode

A LOW level on pin STB selects Normal mode. In this mode, the transceiver can transmit and receive data via the bus lines CANH and CANL (see [Figure 1](#) for the block diagram). The differential receiver converts the analog data on the bus lines into digital data which is output on pin RXD. The slopes of the output signals on the bus lines are controlled internally and are optimized in a way that guarantees the lowest possible EME.

7.1.2 Standby mode

A HIGH level on pin STB selects Standby mode. In Standby mode, the transceiver is not able to transmit or correctly receive data via the bus lines. The transmitter and Normal-mode receiver blocks are switched off to reduce supply current, and only a low-power differential receiver monitors the bus lines for activity.

In Standby mode, the bus lines are biased to ground to minimize system supply current. The low-power receiver is supplied from V_{IO} (V_{CC} in non-V_{IO} variants) and can detect CAN bus activity even if V_{IO} is the only available supply voltage. Pin RXD follows the bus after a wake-up request has been detected. A transition to Normal mode is triggered when STB is forced LOW.

7.2 Remote wake-up (via the CAN bus)

The TJA1044 wakes up from Standby mode when a dedicated wake-up pattern (specified in ISO 11898-2: 2024) is detected on the bus. This filtering helps avoid spurious wake-up events. A spurious wake-up sequence could be triggered by, for example, a dominant clamped bus or by dominant phases due to noise or spikes on the bus.

The wake-up pattern consists of:

- a dominant phase of at least $t_{wake(busdom)}$ followed by
- a recessive phase of at least $t_{wake(busrec)}$ followed by
- a dominant phase of at least $t_{wake(busdom)}$

Dominant or recessive bits between the above mentioned phases that are shorter than $t_{wake(busdom)}$ and $t_{wake(busrec)}$ respectively are ignored.

The complete dominant-recessive-dominant pattern must be received within $t_{to(wake)bus}$ to be recognized as a valid wake-up pattern (see Figure 3). Otherwise, the internal wake-up logic is reset. The complete wake-up pattern will then need to be retransmitted to trigger a wake-up event. Pin RXD remains HIGH until the wake-up event has been triggered.

After a wake-up sequence has been detected, the TJA1044 will remain in Standby mode with the bus signals reflected on RXD. Note that dominant or recessive phases lasting less than $t_{fltr(wake)bus}$ will not be detected by the low-power differential receiver and will not be reflected on RXD in Standby mode.

A wake-up event is not flagged on RXD if any of the following events occurs while a valid wake-up pattern is being received:

- The TJA1044 switches to Normal mode
- The complete wake-up pattern was not received within $t_{to(wake)bus}$
- A V_{CC} or V_{IO} undervoltage is detected ($V_{CC} < V_{uvd(swoff)}(V_{CC})$ or $V_{IO} < V_{uvd(swoff)}(V_{IO})$; see Section 7.3.3)

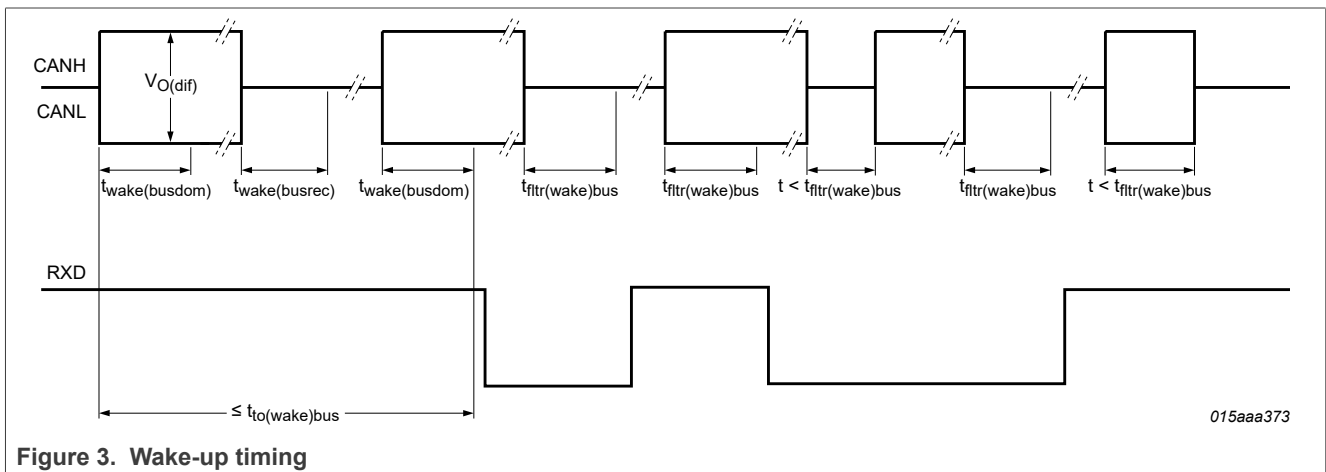

7.3 Fail-safe features

7.3.1 TXD dominant time-out function

A 'TXD dominant time-out' timer is started when pin TXD is set LOW. If the LOW state on this pin persists for longer than $t_{to(dom)TXD}$, the transmitter is disabled, releasing the bus lines to recessive state. This function prevents a hardware and/or software application failure from driving the bus lines to a permanent dominant state (blocking all network communications). The TXD dominant time-out timer is reset when pin TXD is set HIGH.

7.3.2 Internal biasing of TXD and STB input pins

Pins TXD and STB have internal pull-ups to V_{CC} (V_{IO} for variants with a V_{IO} pin) to ensure a safe, defined state in case one or both of these pins are left floating. Pull-up currents flow in these pins in all states; both pins should be held HIGH in Standby mode to minimize supply current.

7.3.3 Undervoltage detection on pins V_{CC} and V_{IO}

If V_{CC} drops below the standby undervoltage detection level, $V_{uvd(stb)}(V_{CC})$, the transceiver switches to Standby mode. The logic state of pin STB is ignored until V_{CC} has recovered.

In versions with a V_{IO} pin, if V_{IO} drops below the switch-off undervoltage detection level ($V_{uvd(swoff)}(V_{IO})$), the transceiver switches off and disengages from the bus (zero load) until V_{IO} has recovered.

In versions without a V_{IO} pin, if V_{CC} drops below the switch-off undervoltage detection level ($V_{\text{uvd}(\text{swoff})(V_{CC})}$), the transceiver switches off and disengages from the bus (zero load) until V_{CC} has recovered.

7.3.4 Overtemperature protection

The output drivers are protected against overtemperature conditions. If the virtual junction temperature exceeds the shutdown junction temperature, $T_{j(\text{sd})}$, both output drivers are disabled. When the virtual junction temperature drops below $T_{j(\text{sd})}$ again, the output drivers recover once TXD has been reset to HIGH. Including the TXD condition prevents output driver oscillation due to small variations in temperature.

7.4 V_{IO} supply pin (TJA1044GT(K)/3 and TJA1044BT(K) variants)

Pin V_{IO} should be connected to the microcontroller supply voltage (see [Figure 6](#)). This will adjust the signal levels of pins TXD, RXD and STB to the I/O levels of the microcontroller. Pin V_{IO} also provides the internal supply voltage for the low-power differential receiver in the transceiver. For applications running in low-power mode, this allows the bus lines to be monitored for activity even if there is no supply voltage on pin V_{CC} .

For variants of the TJA1044 without a V_{IO} pin, all circuitry is connected to V_{CC} (pin 5 is not bonded). The signal levels of pins TXD, RXD and STB are then compatible with 5 V microcontrollers. This allows the device to interface with both 3.3 V (except TJA1044C) and 5 V-supplied microcontrollers, provided the microcontroller I/Os are 5 V tolerant.

8 Limiting values

Table 5. Limiting values

In accordance with the Absolute Maximum Rating System (IEC 60134); all voltages are referenced to ground.

Symbol	Parameter	Conditions	Min	Max	Unit
V _x	voltage on pin x ^[1]	on pins CANH, CANL	-42	+42	V
		on pin V _{CC} , V _{IO}	-0.3	+7	V
		on any other pin ^[2]	-0.3	V _{IO} + 0.3 ^[3]	V
V _(CANH-CANL)	voltage between pin CANH and pin CANL		-27	+27	V
V _{trt}	transient voltage	on pins CANH and CANL ^[4]			
		pulse 1	-100	-	V
		pulse 2a	-	75	V
		pulse 3a	-150	-	V
		pulse 3b	-	100	V
V _{ESD}	electrostatic discharge voltage	IEC 61000-4-2 (150 pF, 330 Ω discharge circuit) ^[5]			
		on pins CANH and CANL	-8	+8	kV
		SAE J2962-2:2019 (330 pF, 2kΩ) on pins CANH, CANL ^[6]			
		powered air discharge	-15	+15	kV
		powered contact discharge	-8	+8	kV
		Human Body Model (HBM)			
		on any pin ^[7]	-4	+4	kV
		on pins CANH and CANL ^[8]	-8	+8	kV
		Machine Model (MM); 200 pF, 0.75 μH, 10 Ω ^[9]			
		on any pin	-200	+200	V
		Charged Device Model (CDM) ^[10]			
on corner pins	-750	+750	V		
on any other pin	-500	+500	V		
T _{vj}	virtual junction temperature	^[11]	-40	+150	°C
T _{stg}	storage temperature	^[12]	-55	+150	°C

[1] The device can sustain voltages up to the specified values over the product lifetime, provided applied voltages (including transients) never exceed these values.
 [2] Maximum voltage should never exceed 7 V.
 [3] V_{CC} + 0.3 in the non-V_{IO} product variants.
 [4] Verified by an external test house according to IEC TS 62228, Section 4.2.4; parameters for standard pulses defined in ISO 7637.
 [5] Verified by an external test house according to IEC TS 62228, Section 4.3.
 [6] Verified by an external test house according to ISO 10605 for TJA1044B/C.
 [7] According to AEC-Q100-002.
 [8] Pins stressed to reference group containing all ground and supply pins, emulating the application circuits (Figure 5 and Figure 6). HBM pulse as specified in AEC-Q100-002 used.
 [9] According to AEC-Q100-003.
 [10] According to AEC-Q100-011.
 [11] In accordance with IEC 60747-1. An alternative definition of virtual junction temperature is: T_{vj} = T_{amb} + P × R_{th(vj-a)}, where R_{th(vj-a)} is a fixed value to be used for the calculation of T_{vj}. The rating for T_{vj} limits the allowable combinations of power dissipation (P) and ambient temperature (T_{amb}).
 [12] T_{stg} in application according to IEC61360-4. For component transport and storage conditions, see instead IEC61760-2.

9 Thermal characteristics

Table 6. Thermal characteristics

Value determined for free convection conditions on a JEDEC 2S2P board.

Symbol	Parameter	Conditions ^[1]	Typ	Unit
R _{th(j-a)}	thermal resistance from junction to ambient	SO8 package; in free air	94	K/W
		HVSON8 package; in free air	54	K/W
R _{th(j-c)}	thermal resistance from junction to case	HVSON8 package; in free air	16	K/W
Ψ _{j-top}	thermal characterization parameter from junction to top of package	SO8 package; in free air	13	K/W
		HVSON8 package; in free air	6	K/W

[1] According to JEDEC JESD51-2, JESD51-5 and JESD51-7 at natural convection on 2s2p board. Board with two inner copper layers (thickness: 35 μm) and thermal via array under the exposed pad connected to the first inner copper layer (thickness: 70 μm).

10 Static characteristics

Table 7. Static characteristics

T_{vj} = -40 °C to +150 °C; V_{CC} = 4.5 V to 5.5 V; V_{IO} = 2.91 V to 5.5 V^[1]; R_L = 60 Ω; C_L = 100 pF unless otherwise specified; all voltages are defined with respect to ground; positive currents flow into the IC.^[2]

Symbol	Parameter	Conditions	Min	Typ	Max	Unit
Supply; pin V_{CC}						
V _{CC}	supply voltage		4.5	-	5.5	V
V _{uvd(stb)(VCC)}	standby undervoltage detection voltage on pin V _{CC}		^[3] 3.5	4	4.3	V
V _{uvd(swoff)(VCC)}	switch-off undervoltage detection voltage on pin V _{CC}	TJA1044T, GT, GTK	^[3] 1.3	2.4	3.4	V
		TJA1044C	^[3] 2.4	2.6	2.8	V
I _{CC}	supply current	Standby mode				
		TJA1044T, GT, GTK; V _{TXD} = V _{CC}	-	10	15	μA
		TJA1044C; V _{TXD} = V _{CC}	-	10	17.5	μA
		variants with a V _{IO} pin; V _{TXD} = V _{IO}	-	0.1	1	μA
		Normal mode				
		recessive; V _{TXD} = V _{IO} ^[4]	2	5	10	mA
		dominant; V _{TXD} = 0 V	20	45	60	mA
dominant; V _{TXD} = 0 V; short circuit on bus lines; -3 V < (V _{CANH} = V _{CANL}) < +18 V	2	80	110	mA		
I/O level adapter supply; pin V_{IO} ^[1]						
V _{IO}	supply voltage on pin V _{IO}		2.91	-	5.5	V

Table 7. Static characteristics...continued

$T_{vj} = -40\text{ }^{\circ}\text{C}$ to $+150\text{ }^{\circ}\text{C}$; $V_{CC} = 4.5\text{ V}$ to 5.5 V ; $V_{IO} = 2.91\text{ V}$ to 5.5 V ^[1]; $R_L = 60\text{ }\Omega$; $C_L = 100\text{ pF}$ unless otherwise specified; all voltages are defined with respect to ground; positive currents flow into the IC.^[2]

Symbol	Parameter	Conditions	Min	Typ	Max	Unit
I_{IO}	supply current on pin V_{IO}	Standby mode; $V_{TXD} = V_{IO}$ ^[4]	-	10	16.5	μA
		Normal mode				
		recessive; $V_{TXD} = V_{IO}$ ^[4]	10	17	30	μA
		dominant; $V_{TXD} = 0\text{ V}$	-	170	300	μA
$V_{uvd(\text{swoff})(VIO)}$	switch-off undervoltage detection voltage on pin V_{IO}	variants with a V_{IO} pin ^[3]	2.4	2.6	2.8	V
Standby mode control input; pin STB						
V_{IH}	HIGH-level input voltage	variants with a V_{IO} pin	$0.7V_{IO}$	-	$V_{IO} + 0.3$	V
		TJA1044C	$0.7V_{CC}$	-	$V_{CC} + 0.3$	V
		TJA1044T, GT, GTK	2	-	$V_{CC} + 0.3$	V
V_{IL}	LOW-level input voltage	variants with a V_{IO} pin	-0.3	-	$+0.3V_{IO}$	V
		TJA1044C	-0.3	-	$+0.3V_{CC}$	V
		TJA1044T, GT, GTK	-0.3	-	+0.8	V
I_{IH}	HIGH-level input current	$V_{STB} = V_{IO}$ ^[4]	-1	-	+1	μA
I_{IL}	LOW-level input current	$V_{STB} = 0\text{ V}$	-15	-	-1	μA
CAN transmit data input; pin TXD						
V_{IH}	HIGH-level input voltage	variants with a V_{IO} pin	$0.7V_{IO}$	-	$V_{IO} + 0.3$	V
		TJA1044C	$0.7V_{CC}$	-	$V_{CC} + 0.3$	V
		TJA1044T, GT, GTK	2	-	$V_{CC} + 0.3$	V
V_{IL}	LOW-level input voltage	variants with a V_{IO} pin	-0.3	-	$+0.3V_{IO}$	V
		TJA1044C	-0.3	-	$+0.3V_{CC}$	V
		TJA1044T, GT, GTK	-0.3	-	+0.8	V
I_{IH}	HIGH-level input current	$V_{TXD} = V_{IO}$ ^[4]	-5	-	+5	μA
I_{IL}	LOW-level input current	$V_{TXD} = 0\text{ V}$; variants with a V_{IO} pin	-270	-150	-60	μA
		$V_{TXD} = 0\text{ V}$; variants without a V_{IO} pin	-270	-150	-65	μA
C_i	input capacitance	^[5]	-	5	10	pF
CAN receive data output; pin RXD						
I_{OH}	HIGH-level output current	$V_{RXD} = V_{IO}$ ^[4] - 0.4 V	-9	-3	-1	mA
I_{OL}	LOW-level output current	$V_{RXD} = 0.4\text{ V}$; bus dominant	1	-	12	mA

Table 7. Static characteristics...continued

$T_{vj} = -40\text{ }^{\circ}\text{C}$ to $+150\text{ }^{\circ}\text{C}$; $V_{CC} = 4.5\text{ V}$ to 5.5 V ; $V_{IO} = 2.91\text{ V}$ to $5.5\text{ V}^{[1]}$; $R_L = 60\text{ }\Omega$; $C_L = 100\text{ pF}$ unless otherwise specified; all voltages are defined with respect to ground; positive currents flow into the IC.^[2]

Symbol	Parameter	Conditions	Min	Typ	Max	Unit	
Bus lines; pins CANH and CANL							
$V_{O(\text{dom})}$	dominant output voltage	$V_{\text{TXD}} = 0\text{ V}$; $t < t_{\text{to}(\text{dom})\text{TXD}}$					
		pin CANH; $R_L = 50\text{ }\Omega$ to $65\text{ }\Omega$	2.75	3.5	4.5	V	
		pin CANL; $R_L = 50\text{ }\Omega$ to $65\text{ }\Omega$	0.5	1.5	2.25	V	
$V_{\text{dom}(\text{TX})\text{sym}}$	transmitter dominant voltage symmetry	$V_{\text{dom}(\text{TX})\text{sym}} = V_{CC} - V_{\text{CANH}} - V_{\text{CANL}}$	-400	-	+400	mV	
V_{TXsym}	transmitter voltage symmetry	$V_{\text{TXsym}} = V_{\text{CANH}} + V_{\text{CANL}}$; $f_{\text{TXD}} = 250\text{ kHz}$, 1 MHz and 2.5 MHz ; $C_{\text{SPLIT}} = 4.7\text{ nF}$	^[5] ^[6] 0.9 V_{CC}	-	1.1 V_{CC}	V	
$V_{O(\text{dif})}$	differential output voltage	dominant; Normal mode; $V_{\text{TXD}} = 0\text{ V}$; $t < t_{\text{to}(\text{dom})\text{TXD}}$					
		$R_L = 50\text{ }\Omega$ to $65\text{ }\Omega$	1.5	-	3	V	
		$R_L = 45\text{ }\Omega$ to $70\text{ }\Omega$	1.4	-	3.3	V	
		$R_L = 2240\text{ }\Omega$	1.5	-	5	V	
		recessive					
		Normal mode: $V_{\text{TXD}} = V_{IO}^{[4]}$; no load	-50	-	+50	mV	
$V_{O(\text{rec})}$	recessive output voltage	Normal mode; $V_{\text{TXD}} = V_{IO}^{[4]}$; no load	2	0.5 V_{CC}	3	V	
		Standby mode; no load	-0.1	-	+0.1	V	
$V_{\text{th}(\text{RX})\text{dif}}$	differential receiver threshold voltage	$-12\text{ V} \leq V_{\text{CANL}} \leq +12\text{ V}$; $-12\text{ V} \leq V_{\text{CANH}} \leq +12\text{ V}$					
		Normal mode	0.5	-	0.9	V	
		Standby mode	0.4	-	1.15	V	
$V_{\text{rec}(\text{RX})}$	receiver recessive voltage	$-12\text{ V} \leq V_{\text{CANL}} \leq +12\text{ V}$; $-12\text{ V} \leq V_{\text{CANH}} \leq +12\text{ V}$					
		Normal mode ^[5]	-4	-	+0.5	V	
		Standby mode ^[5]	-4	-	+0.4	V	
$V_{\text{dom}(\text{RX})}$	receiver dominant voltage	$-12\text{ V} \leq V_{\text{CANL}} \leq +12\text{ V}$; $-12\text{ V} \leq V_{\text{CANH}} \leq +12\text{ V}$					
		Normal mode ^[5]	0.9	-	9.0	V	
		Standby mode ^[5]	1.15	-	9.0	V	
$V_{\text{hys}(\text{RX})\text{dif}}$	differential receiver hysteresis voltage	$-12\text{ V} \leq V_{\text{CANL}} \leq +12\text{ V}$; $-12\text{ V} \leq V_{\text{CANH}} \leq +12\text{ V}$; Normal mode	50	-	300	mV	
$I_{O(\text{sc})\text{dom}}$	dominant short-circuit output current	$V_{\text{TXD}} = 0\text{ V}$; $t < t_{\text{to}(\text{dom})\text{TXD}}$; $V_{CC} = 5\text{ V}$					
		pin CANH; $V_{\text{CANH}} = -15\text{ V}$ to $+40\text{ V}$	-100	-70	-	mA	
		pin CANL; $V_{\text{CANL}} = -15\text{ V}$ to $+40\text{ V}$	-	70	100	mA	

Table 7. Static characteristics...continued

$T_{vj} = -40\text{ °C to }+150\text{ °C}$; $V_{CC} = 4.5\text{ V to }5.5\text{ V}$; $V_{IO} = 2.91\text{ V to }5.5\text{ V}^{[1]}$; $R_L = 60\text{ }\Omega$; $C_L = 100\text{ pF}$ unless otherwise specified; all voltages are defined with respect to ground; positive currents flow into the IC.^[2]

Symbol	Parameter	Conditions	Min	Typ	Max	Unit
$I_{O(sc)rec}$	recessive short-circuit output current	Normal mode; $V_{TXD} = V_{IO}^{[4]}$; $V_{CANH} = V_{CANL} = -27\text{ V to }+32\text{ V}$	-5	-	+5	mA
I_L	leakage current	$V_{CC} = V_{IO} = 0\text{ V}$ or $V_{CC} = V_{IO} = \text{shorted to GND via }47\text{ k}\Omega$; $V_{CANH} = V_{CANL} = 5\text{ V}$	-5	-	+5	μA
R_i	input resistance	$-2\text{ V} \leq V_{CANL} \leq +7\text{ V}$; $-2\text{ V} \leq V_{CANH} \leq +7\text{ V}$	^[5] 9	15	28	k Ω
ΔR_i	input resistance deviation	$0\text{ V} \leq V_{CANL} \leq +5\text{ V}$; $0\text{ V} \leq V_{CANH} \leq +5\text{ V}$	^[5] -3	-	+3	%
$R_{i(dif)}$	differential input resistance	$-2\text{ V} \leq V_{CANL} \leq +7\text{ V}$; $-2\text{ V} \leq V_{CANH} \leq +7\text{ V}$	^[5] 19	30	52	k Ω
$C_{i(cm)}$	common-mode input capacitance		^[5] -	-	20	pF
$C_{i(dif)}$	differential input capacitance		^[5] -	-	10	pF
Temperature detection						
$T_{j(sd)}$	shutdown junction temperature		^[5] -	185	-	$^{\circ}\text{C}$

[1] Only the TJA1044GT(K)/3 and TJA1044BT(K) variants have a V_{IO} pin; all circuitry is connected to V_{CC} in the other variants.
 [2] All parameters are guaranteed over the virtual junction temperature range by design. Factory testing uses correlated test conditions to cover the specified temperature and power supply voltage range.
 [3] Undervoltage is detected between min and max values. Undervoltage is guaranteed to be detected below min value and guaranteed not to be detected above max value.
 [4] $V_{IO} = V_{CC}$ in non- V_{IO} product variants.
 [5] Not tested in production; guaranteed by design.
 [6] The test circuit used to measure the bus output voltage symmetry and the common-mode voltages (which includes C_{SPLIT}) is shown in [Figure 8](#).

11 Dynamic characteristics

Table 8. Dynamic characteristics

$T_{vj} = -40\text{ °C to }+150\text{ °C}$; $V_{CC} = 4.5\text{ V to }5.5\text{ V}$; $V_{IO} = 2.91\text{ V to }5.5\text{ V}^{[1]}$; $R_L = 60\text{ }\Omega$; $C_L = 100\text{ pF}$ unless specified otherwise; all voltages are defined with respect to ground.^[2]

Symbol	Parameter	Conditions	Min	Typ	Max	Unit
Transceiver timing; pins CANH, CANL, TXD and RXD; see Figure 4 and Figure 7						
$t_{d(TXD-busdom)}$	delay time from TXD to bus dominant	TJA1044B/C; Normal mode ^[3]	-	62	90	ns
		other variants; Normal mode ^[3]	-	65	100	ns
$t_{d(TXD-busrec)}$	delay time from TXD to bus recessive	TJA1044B/C; Normal mode ^[3]	-	75	90	ns
		other variants; Normal mode ^[3]	-	90	100	ns
$t_{d(busdom-RXD)}$	delay time from bus dominant to RXD	TJA1044B/C; Normal mode ^[3]	-	105	115	ns
		other variants; Normal mode ^[3]	-	60	140	ns
$t_{d(busrec-RXD)}$	delay time from bus recessive to RXD	TJA1044B/C; Normal mode ^[3]	-	90	110	ns
		other variants; Normal mode ^[3]	-	65	125	ns
$t_{d(TXDL-RXDL)}$	delay time from TXD LOW to RXD LOW	TJA1044B/C; Normal mode	50	-	185	ns
		TJA1044T; Normal mode	50	-	230	ns
		all other variants; Normal mode	50	-	210	ns
$t_{d(TXDH-RXDH)}$	delay time from TXD HIGH to RXD HIGH	TJA1044B/C; Normal mode	50	-	185	ns
		TJA1044T; Normal mode	50	-	230	ns
		all other variants; Normal mode	50	-	210	ns
CAN FD timing characteristics according to ISO 11898-2:2024 parameter set B ($t_{bit(TXD)} \geq 200\text{ ns}$, up to 5 Mbit/s); see Figure 4 and Figure 7						
$\Delta t_{bit(bus)}$	transmitted recessive bit width deviation	$\Delta t_{bit(bus)} = t_{bit(bus)} - t_{bit(TXD)}$	-45	-	+10	ns
$\Delta t_{bit(RXD)}$	received recessive bit width deviation	$\Delta t_{bit(RXD)} = t_{bit(RXD)} - t_{bit(TXD)}$	-80	-	+20	ns
Δt_{rec}	receiver timing symmetry	$\Delta t_{rec} = t_{bit(RXD)} - t_{bit(bus)}$	-45	-	+15	ns
CAN FD timing characteristics according to ISO 11898-2:2024 parameter set A ($t_{bit(TXD)} \geq 500\text{ ns}$, up to 2 Mbit/s); see Figure 4 and Figure 7						
$\Delta t_{bit(bus)}$	transmitted recessive bit width deviation	$\Delta t_{bit(bus)} = t_{bit(bus)} - t_{bit(TXD)}$	-65	-	+30	ns
$\Delta t_{bit(RXD)}$	received recessive bit width deviation	$\Delta t_{bit(RXD)} = t_{bit(RXD)} - t_{bit(TXD)}$	-100	-	+50	ns
Δt_{rec}	receiver timing symmetry	$\Delta t_{rec} = t_{bit(RXD)} - t_{bit(bus)}$	-65	-	+40	ns
Dominant time-out time						
$t_{to(dom)TXD}$	TXD dominant time-out time	$V_{TXD} = 0\text{ V}$; Normal mode ^[4]	0.8	3	6.5	ms
Mode transitions						
$t_{d(stb-norm)}$	standby to normal mode delay time		^[5] 7	25	47	μs
Bus wake-up timing; pins CANH and CANL; see Figure 3						
$t_{wake(busdom)}$	bus dominant wake-up time	Standby mode ^[6]				
		TJA1044T, GT, GTK	0.5	-	3	μs
		all other variants	0.5	-	1.8	μs
$t_{wake(busrec)}$	bus recessive wake-up time	Standby mode ^[6]				

Table 8. Dynamic characteristics...continued

$T_{vj} = -40\text{ }^{\circ}\text{C}$ to $+150\text{ }^{\circ}\text{C}$; $V_{CC} = 4.5\text{ V}$ to 5.5 V ; $V_{IO} = 2.91\text{ V}$ to $5.5\text{ V}^{[1]}$; $R_L = 60\text{ }\Omega$; $C_L = 100\text{ pF}$ unless specified otherwise; all voltages are defined with respect to ground.^[2]

Symbol	Parameter	Conditions	Min	Typ	Max	Unit
		TJA1044T, GT, GTK	0.5	-	3	μs
		all other variants	0.5	-	1.8	μs
$t_{\text{to(wake)bus}}$	bus wake-up time-out time	Standby mode ^[4]	0.8	3	6.5	ms
$t_{\text{ftr(wake)bus}}$	bus wake-up filter time	Standby mode ^[7]				
		TJA1044T, GT, GTK	0.5	1	3	μs
		all other variants	0.5	-	1.8	μs

- [1] Only TJA1044GT(K)/3 and TJA1044BT(K) variants have a V_{IO} pin; all circuitry is connected to V_{CC} in the other variants.
- [2] All parameters are guaranteed over the junction temperature range by design. Factory testing uses correlated test conditions to cover the specified temperature and power supply voltage range.
- [3] Not tested in production; guaranteed by design.
- [4] Time-out occurs between the min and max values. Time-out is guaranteed not to occur below the min value; time-out is guaranteed to occur above the max value.
- [5] Standby-to-Normal mode transition occurs between the min and max values. It is guaranteed not to occur below the min value; it is guaranteed to occur above the max value.
- [6] A dominant/recessive phase shorter than the min value is guaranteed not to be seen as a dominant/recessive bit; a dominant/recessive phase longer than the max value is guaranteed to be seen as a dominant/recessive bit.
- [7] Pulses shorter than the min value are guaranteed to be filtered out; pulses longer than the max value are guaranteed to be processed.

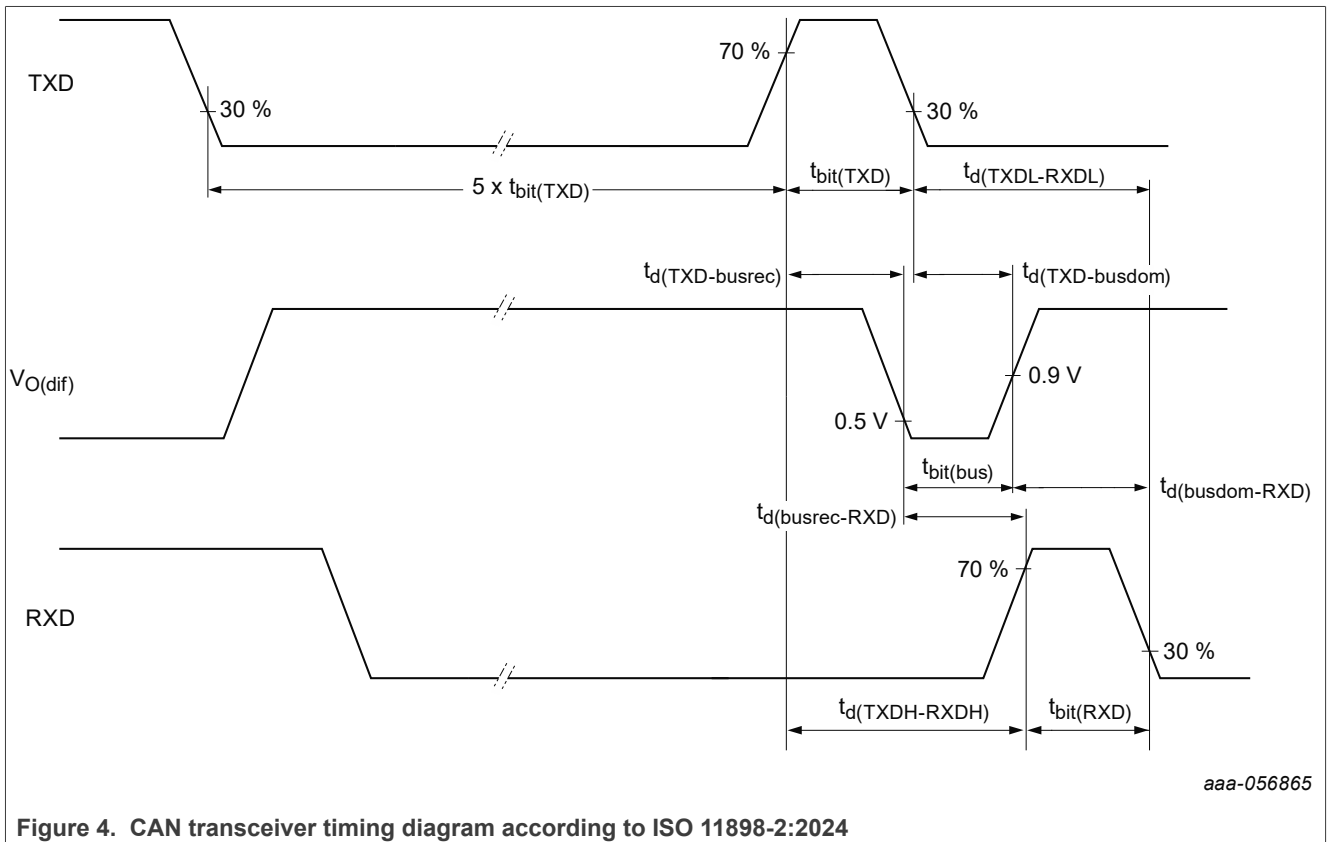
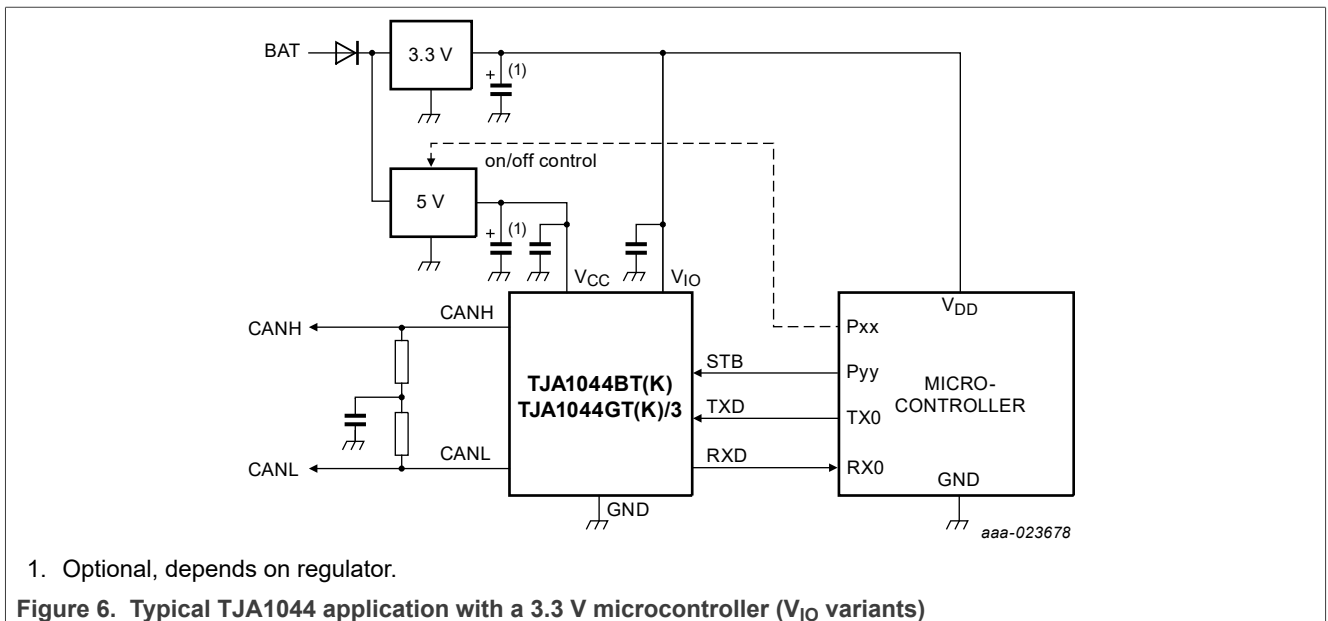
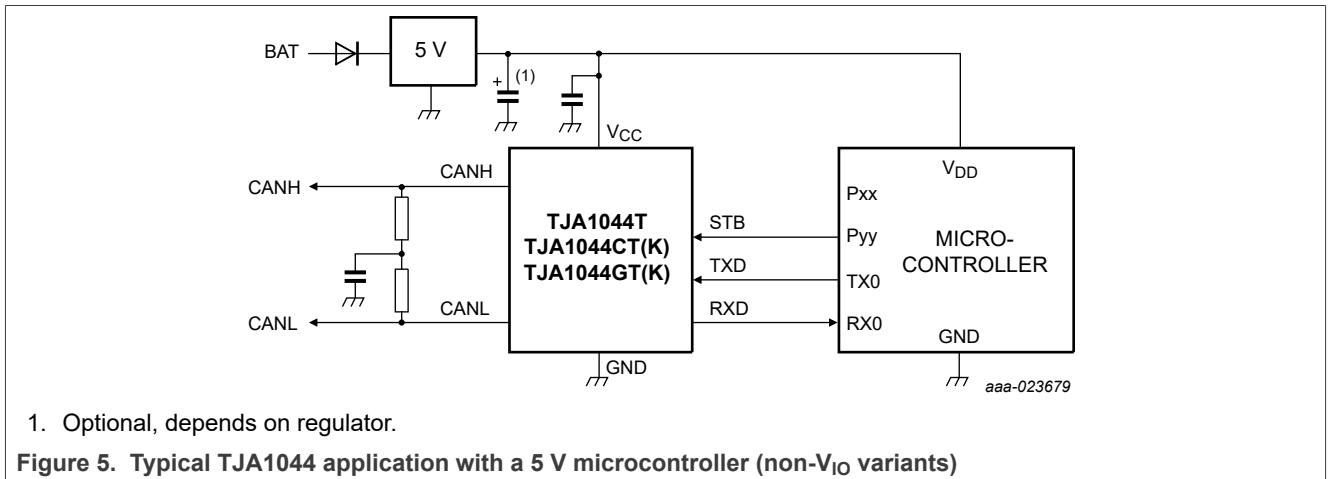

Figure 4. CAN transceiver timing diagram according to ISO 11898-2:2024

12 Application information

The minimum external circuitry needed with the TJA1044 is shown in [Figure 5](#) and [Figure 6](#). See the Application Hints ([Section 12.2](#)) for further information about external components and PCB layout requirements.

12.1 Application diagrams



12.2 Application hints

Further information on the application of the TJA1044 can be found in NXP application hints *AH1308 Application Hints - Standalone high-speed CAN transceivers Mantis TJA1044/TJA1057 and Dual-Mantis TJA1046*.

13 Test information

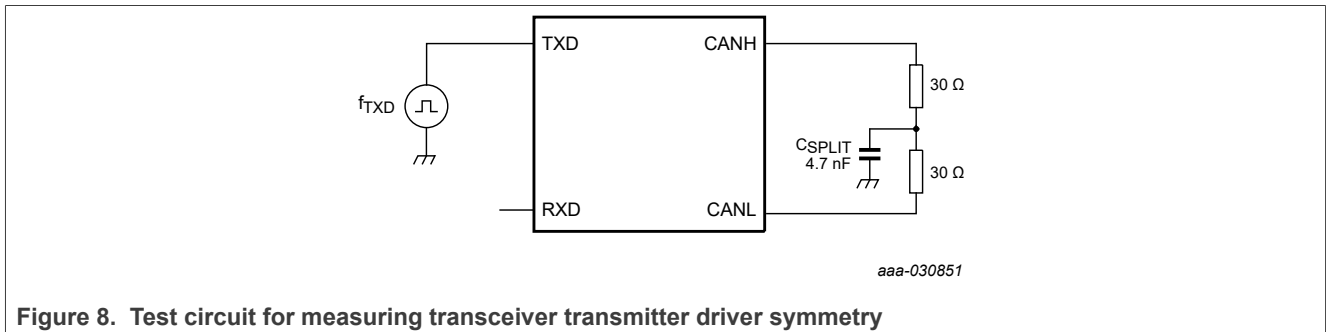
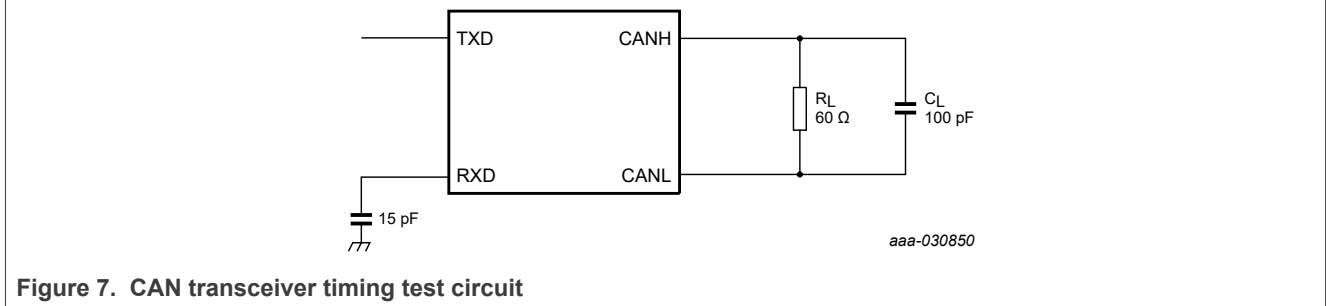

13.1 Quality information

This product has been qualified in accordance with the Automotive Electronics Council (AEC) standard Q100 Rev-G - Failure mechanism based stress test qualification for integrated circuits, and is suitable for use in automotive applications.

14 Package outline

SO8: plastic small outline package; 8 leads; body width 3.9 mm

SOT96-1

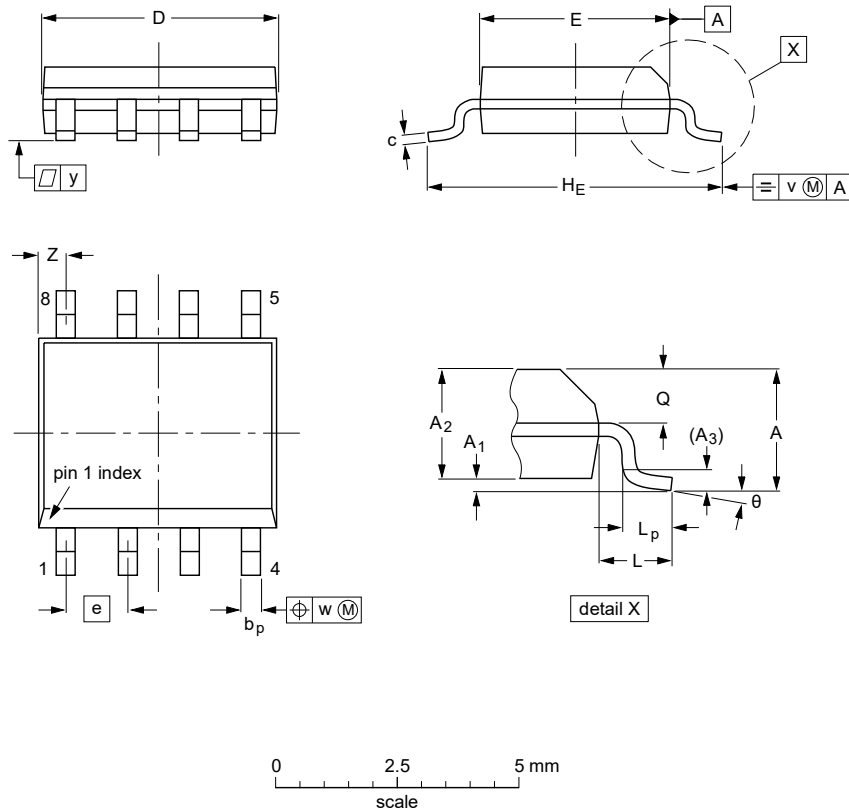

DIMENSIONS (inch dimensions are derived from the original mm dimensions)

UNIT	A max.	A ₁	A ₂	A ₃	b _p	c	D ⁽¹⁾	E ⁽²⁾	e	H _E	L	L _p	Q	v	w	y	Z ⁽¹⁾	θ
mm	1.75	0.25 0.10	1.45 1.25	0.25	0.49 0.36	0.25 0.19	5.0 4.8	4.0 3.8	1.27	6.2 5.8	1.05	1.0 0.4	0.7 0.6	0.25	0.25	0.1	0.7 0.3	8° 0°
inches	0.069	0.010 0.004	0.057 0.049	0.01	0.019 0.014	0.0100 0.0075	0.20 0.19	0.16 0.15	0.05	0.244 0.228	0.041	0.039 0.016	0.028 0.024	0.01	0.01	0.004	0.028 0.012	

Notes

1. Plastic or metal protrusions of 0.15 mm (0.006 inch) maximum per side are not included.
2. Plastic or metal protrusions of 0.25 mm (0.01 inch) maximum per side are not included.

OUTLINE VERSION	REFERENCES			EUROPEAN PROJECTION	ISSUE DATE
	IEC	JEDEC	JEITA		
SOT96-1	076E03	MS-012			99-12-27 03-02-18

Figure 9. Package outline SOT96-1 (SO8)

HVSON8: plastic thermal enhanced very thin small outline package; no leads;
8 terminals; body 3 x 3 x 0.85 mm

SOT782-1

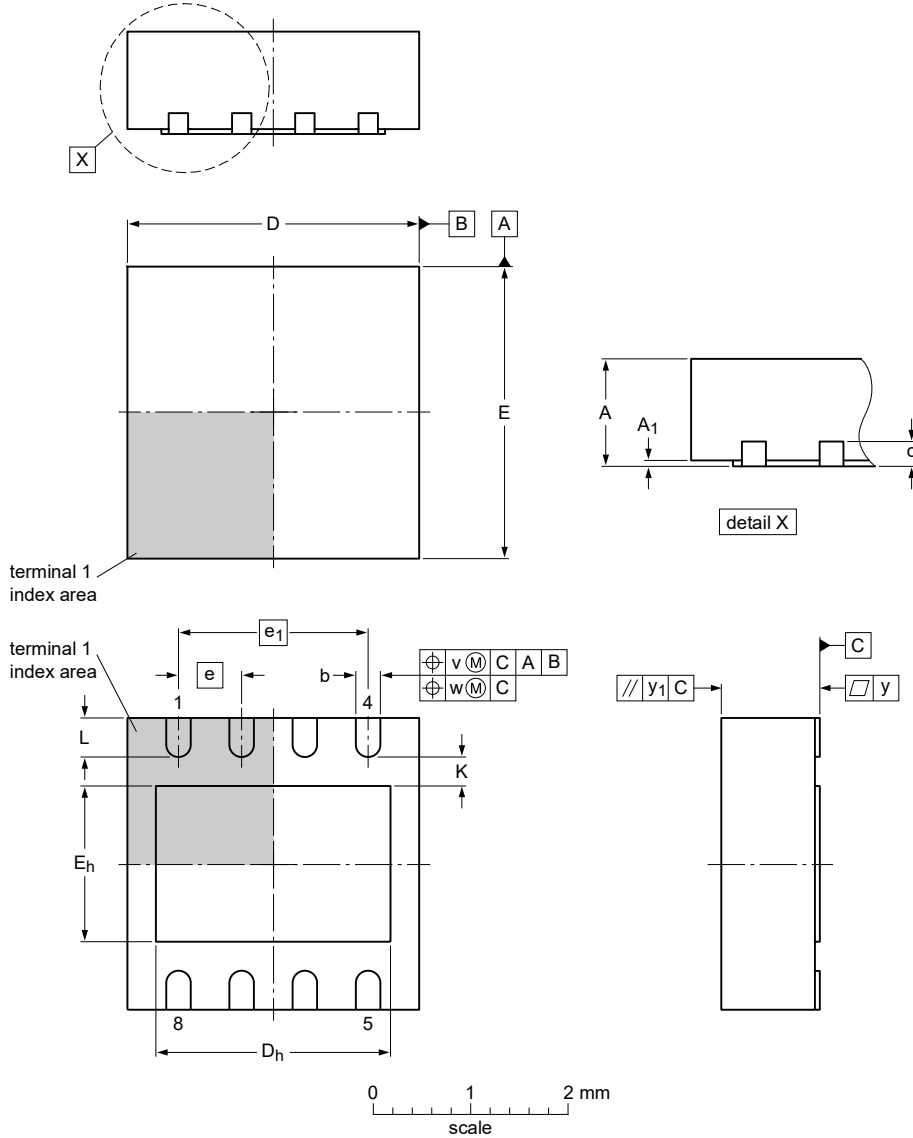

Dimensions

Unit ⁽¹⁾	A	A ₁	b	c	D	D _h	E	E _h	e	e ₁	K	L	v	w	y	y ₁
max	1.00	0.05	0.35		3.10	2.45	3.10	1.65			0.35	0.45				
mm nom	0.85	0.03	0.30	0.2	3.00	2.40	3.00	1.60	0.65	1.95	0.30	0.40	0.1	0.05	0.05	0.1
min	0.80	0.00	0.25		2.90	2.35	2.90	1.55			0.25	0.35				

Note

1. Plastic or metal protrusions of 0.075 maximum per side are not included.

sot782-1_po

Outline version	References				European projection	Issue date
	IEC	JEDEC	JEITA			
SOT782-1	---	MO-229	---			-09-08-25- 09-08-28

Figure 10. Package outline SOT782-1 (HVSON8)

15 Handling information

All input and output pins are protected against ElectroStatic Discharge (ESD) under normal handling. When handling ensure that the appropriate precautions are taken as described in *JESD625-A* or equivalent standards.

16 Soldering of SMD packages

This text provides a very brief insight into a complex technology. A more in-depth account of soldering ICs can be found in Application Note *AN10365 "Surface mount reflow soldering description"*.

16.1 Introduction to soldering

Soldering is one of the most common methods through which packages are attached to Printed Circuit Boards (PCBs), to form electrical circuits. The soldered joint provides both the mechanical and the electrical connection. There is no single soldering method that is ideal for all IC packages. Wave soldering is often preferred when through-hole and Surface Mount Devices (SMDs) are mixed on one printed wiring board; however, it is not suitable for fine pitch SMDs. Reflow soldering is ideal for the small pitches and high densities that come with increased miniaturization.

16.2 Wave and reflow soldering

Wave soldering is a joining technology in which the joints are made by solder coming from a standing wave of liquid solder. The wave soldering process is suitable for the following:

- Through-hole components
- Leaded or leadless SMDs, which are glued to the surface of the printed circuit board

Not all SMDs can be wave soldered. Packages with solder balls, and some leadless packages which have solder lands underneath the body, cannot be wave soldered. Also, leaded SMDs with leads having a pitch smaller than ~0.6 mm cannot be wave soldered, due to an increased probability of bridging.

The reflow soldering process involves applying solder paste to a board, followed by component placement and exposure to a temperature profile. Leaded packages, packages with solder balls, and leadless packages are all reflow solderable.

Key characteristics in both wave and reflow soldering are:

- Board specifications, including the board finish, solder masks and vias
- Package footprints, including solder thieves and orientation
- The moisture sensitivity level of the packages
- Package placement
- Inspection and repair
- Lead-free soldering versus SnPb soldering

16.3 Wave soldering

Key characteristics in wave soldering are:

- Process issues, such as application of adhesive and flux, clinching of leads, board transport, the solder wave parameters, and the time during which components are exposed to the wave
- Solder bath specifications, including temperature and impurities

16.4 Reflow soldering

Key characteristics in reflow soldering are:

- Lead-free versus SnPb soldering; note that a lead-free reflow process usually leads to higher minimum peak temperatures (see [Figure 11](#)) than a SnPb process, thus reducing the process window
- Solder paste printing issues including smearing, release, and adjusting the process window for a mix of large and small components on one board
- Reflow temperature profile; this profile includes preheat, reflow (in which the board is heated to the peak temperature) and cooling down. It is imperative that the peak temperature is high enough for the solder to make reliable solder joints (a solder paste characteristic). In addition, the peak temperature must be low enough that the packages and/or boards are not damaged. The peak temperature of the package depends on package thickness and volume and is classified in accordance with [Table 9](#) and [Table 10](#)

Table 9. SnPb eutectic process (from J-STD-020D)

Package thickness (mm)	Package reflow temperature (°C)	
	Volume (mm³)	
	< 350	≥ 350
< 2.5	235	220
≥ 2.5	220	220

Table 10. Lead-free process (from J-STD-020D)

Package thickness (mm)	Package reflow temperature (°C)		
	Volume (mm³)		
	< 350	350 to 2000	> 2000
< 1.6	260	260	260
1.6 to 2.5	260	250	245
> 2.5	250	245	245

Moisture sensitivity precautions, as indicated on the packing, must be respected at all times.

Studies have shown that small packages reach higher temperatures during reflow soldering, see [Figure 11](#).

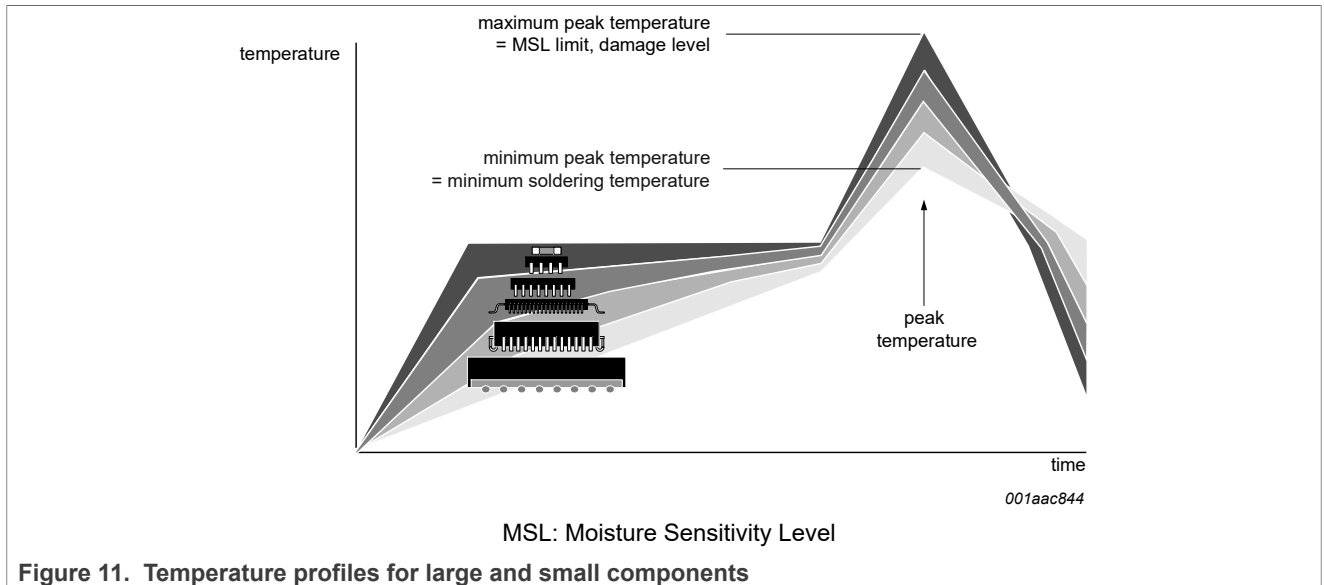

Figure 11. Temperature profiles for large and small components

For further information on temperature profiles, refer to Application Note AN10365 “Surface mount reflow soldering description”.

17 Appendix: ISO 11898-2:2024 parameter cross-reference lists

Table 11. ISO 11898-2:2024 to NXP data sheet parameter conversion^[1]

ISO 11898-2:2024		NXP data sheet	
Parameter	Notation	Symbol	Parameter
HS-PMA maximum ratings of V_{CAN_H}, V_{CAN_L} and V_{Diff}			
Maximum rating	V_{Diff}	$V_{(CANH-CANL)}$	voltage between pin CANH and pin CANL
General maximum rating	V_{CAN_H}	V_x	voltage on pin x
Optional: Extended maximum rating	V_{CAN_L}		
HS-PMA recessive output characteristics, bus biasing active/inactive			
Single ended output voltage on CAN_H	V_{CAN_H}	$V_{O(rec)}$	recessive output voltage
Single ended output voltage on CAN_L	V_{CAN_L}		
Differential output voltage	V_{Diff}	$V_{O(dif)}$	differential output voltage
HS-PMA dominant output characteristics			
Single ended voltage on CAN_H	V_{CAN_H}	$V_{O(dom)}$	dominant output voltage
Single ended voltage on CAN_L	V_{CAN_L}		
Differential voltage on normal bus load	V_{Diff}	$V_{O(dif)}$	differential output voltage
Differential voltage on effective resistance during arbitration			
Optional: Differential voltage on extended bus load range			
Maximum HS-PMA driver output current			
Absolute current on CAN_H	I_{CAN_H}	$I_{O(sc)}$	short-circuit output current
Absolute current on CAN_L	I_{CAN_L}		
HS-PMA static receiver input characteristics, bus biasing active/inactive			
Recessive state differential input voltage range	V_{Diff}	$V_{th(RX)dif}$	differential receiver threshold voltage
Dominant state differential input voltage range		$V_{rec(RX)}$	receiver recessive voltage
		$V_{dom(RX)}$	receiver dominant voltage
HS-PMA receiver input resistance (matching)			
Differential internal resistance	$R_{DIFF_pas_rec}$	$R_{i(dif)}$	differential input resistance
Single-ended internal resistance	$R_{SE_pas_rec_H}$ $R_{SE_pas_rec_L}$	R_i	input resistance
Matching of internal resistance	m_R	ΔR_i	input resistance deviation
HS-PMA maximum leakage currents on CAN_H and CAN_L, unpowered			
Leakage current on CAN_H, CAN_L	I_{CAN_H} I_{CAN_L}	I_L	leakage current
HS-PMA driver symmetry			
Driver symmetry	V_{sym_vcc}	V_{TXsym}	transmitter voltage symmetry
Optional HS-PMA transmit dominant time-out			
Transmit dominant time-out	t_{dom}	$t_{to(dom)TXD}$	TXD dominant time-out time

Table 11. ISO 11898-2:2024 to NXP data sheet parameter conversion^[1] ...continued

ISO 11898-2:2024		NXP data sheet	
Parameter	Notation	Symbol	Parameter
HS-PMA implementation loop delay requirements for parameter sets A, B and C			
Loop delay for parameter sets A and B	t_{Loop}	$t_{d(TXDH-RXDH)}$	delay time from TXD HIGH to RXD HIGH
Loop delay for parameter set C		$t_{d(TXDL-RXDL)}$	delay time from TXD LOW to RXD LOW
Propagation delay from TXD to CAN_H/CAN_L for parameter set C	$t_{prop(TXD_BUS)}$	$t_{d(TXD-busdom)}$	delay time from TXD to bus dominant
		$t_{d(TXD-busrec)}$	delay time from TXD to bus recessive
Propagation delay from CAN_H/CAN_L to RXD for parameter set C	$t_{prop(BUS_RXD)}$	$t_{d(busdom-RXD)}$	delay time from bus dominant to RXD
		$t_{d(busrec-RXD)}$	delay time from bus recessive to RXD
HS-PMA implementation data signal timing requirements for parameter sets A, B and C			
Transmitted recessive bit width variation	$t_{\Delta Bit(Bus)}$	$\Delta t_{bit(bus)}$	transmitted recessive bit width deviation
Received recessive bit width variation	$t_{\Delta Bit(RXD)}$	$\Delta t_{bit(RXD)}$	received recessive bit width deviation
Receiver timing symmetry	$t_{\Delta REC}$	Δt_{rec}	receiver timing symmetry
HS-PMA implementation SIC timing and impedance for parameter set C			
Differential internal resistance (CAN_H to CAN_L)	$R_{DIFF_act_rec}$	$R_{i(dif)actrec}$	active recessive phase differential input resistance
Internal single-ended resistance	$R_{SE_act_rec}$	$R_{i(actrec)}$	active recessive phase input resistance
Start time of active signal improvement phase	$t_{act_rec_start}$	$t_{d(TXD-busactrec)start}$	delay time from TXD to bus active recessive start
End time of active signal improvement phase	$t_{act_rec_end}$	$t_{d(TXD-busactrec)end}$	delay time from TXD to bus active recessive end
Start time of passive recessive phase	$t_{pas_rec_start}$	$t_{d(TXD-buspasrec)start}$	delay time from TXD to bus passive recessive start
PMA voltage wake-up control timing			
CAN activity filter time, long/short	t_{Filter}	$t_{wake(busdom)}$	bus dominant wake-up time
		$t_{wake(busrec)}$	bus recessive wake-up time
Wake-up time-out	t_{Wake}	$t_{to(wake)bus}$	bus wake-up time-out time
Wake-up pattern signaling	t_{Flag}	$t_{startup(RXD)}$	RXD start-up time
		$t_{startup(INH)}$	INH start-up time
		$t_{startup(ERR_N)}$	ERR_N start-up time
Number of recessive bits before next SOF			
Number of recessive bits before a new SOF shall be accepted	n_{Bits_idle}	$N_{bit(idle)}$	number of idle bits before a SOF is accepted
BitFilter in CAN FD data phase			
CAN FD data phase bitfilter (option 1)	$\rho_{Bitfilter_option1}$	$t_{ftr(bit)dom}$	dominant bit filter time
CAN FD data phase bitfilter (option 2)	$\rho_{Bitfilter_option2}$		
HS-PMA bus biasing control timing			
Time-out for bus inactivity	$t_{Silence}$	$t_{to(silence)}$	bus silence time-out time
Bus bias reaction time	t_{Bias}	$t_{d(busact-bias)}$	bus bias reaction time

- [1] A number of proprietary NXP parameters are equivalent to parameters defined in ISO 11898-2:2024, but use different symbols. This conversion table allows ISO parameters to be cross-referenced with their NXP counterparts. The NXP parameters are defined in the Static and Dynamic characteristics tables. The conversion table provides a comprehensive listing - individual devices may not include all parameters.

18 Revision history

Table 12. Revision history

Document ID	Release date	Description
TJA1044 v.8.0	6 November 2024	<ul style="list-style-type: none">• ISO 11898-2:2016 upgraded to ISO 11898-2:2024 throughout• Section 2.1: EMC compliance updated• Table 5: SAE J2962-2:2019 V_{ESD} entries added• Table 8: formatting of CAN (FD) timing characteristics revised; table note 3 added• Original Figs. 4 and 5 combined in new single Figure 4• Section 17: cross-reference table updated
TJA1044 v.7.0	16 January 2023	-
TJA1044 v.6.1	24 August 2017	-
TJA1044 v.5.1	23 May 2016	-
TJA1044 v.4.0	10 July 2015	-
TJA1044 v.3.0	19 November 2014	-
TJA1044 v.2.0	30 January 2013	-
TJA1044 v.1.0	30 May 2013	<ul style="list-style-type: none">• Initial version

Legal information

Data sheet status

Document status ^{[1][2]}	Product status ^[3]	Definition
Objective [short] data sheet	Development	This document contains data from the objective specification for product development.
Preliminary [short] data sheet	Qualification	This document contains data from the preliminary specification.
Product [short] data sheet	Production	This document contains the product specification.

[1] Please consult the most recently issued document before initiating or completing a design.

[2] The term 'short data sheet' is explained in section "Definitions".

[3] The product status of device(s) described in this document may have changed since this document was published and may differ in case of multiple devices. The latest product status information is available on the Internet at URL <https://www.nxp.com>.

Definitions

Draft — A draft status on a document indicates that the content is still under internal review and subject to formal approval, which may result in modifications or additions. NXP Semiconductors does not give any representations or warranties as to the accuracy or completeness of information included in a draft version of a document and shall have no liability for the consequences of use of such information.

Short data sheet — A short data sheet is an extract from a full data sheet with the same product type number(s) and title. A short data sheet is intended for quick reference only and should not be relied upon to contain detailed and full information. For detailed and full information see the relevant full data sheet, which is available on request via the local NXP Semiconductors sales office. In case of any inconsistency or conflict with the short data sheet, the full data sheet shall prevail.

Product specification — The information and data provided in a Product data sheet shall define the specification of the product as agreed between NXP Semiconductors and its customer, unless NXP Semiconductors and customer have explicitly agreed otherwise in writing. In no event however, shall an agreement be valid in which the NXP Semiconductors product is deemed to offer functions and qualities beyond those described in the Product data sheet.

Disclaimers

Limited warranty and liability — Information in this document is believed to be accurate and reliable. However, NXP Semiconductors does not give any representations or warranties, expressed or implied, as to the accuracy or completeness of such information and shall have no liability for the consequences of use of such information. NXP Semiconductors takes no responsibility for the content in this document if provided by an information source outside of NXP Semiconductors.

In no event shall NXP Semiconductors be liable for any indirect, incidental, punitive, special or consequential damages (including - without limitation - lost profits, lost savings, business interruption, costs related to the removal or replacement of any products or rework charges) whether or not such damages are based on tort (including negligence), warranty, breach of contract or any other legal theory.

Notwithstanding any damages that customer might incur for any reason whatsoever, NXP Semiconductors' aggregate and cumulative liability towards customer for the products described herein shall be limited in accordance with the Terms and conditions of commercial sale of NXP Semiconductors.

Right to make changes — NXP Semiconductors reserves the right to make changes to information published in this document, including without limitation specifications and product descriptions, at any time and without notice. This document supersedes and replaces all information supplied prior to the publication hereof.

Applications — Applications that are described herein for any of these products are for illustrative purposes only. NXP Semiconductors makes no representation or warranty that such applications will be suitable for the specified use without further testing or modification.

Customers are responsible for the design and operation of their applications and products using NXP Semiconductors products, and NXP Semiconductors accepts no liability for any assistance with applications or customer product design. It is customer's sole responsibility to determine whether the NXP Semiconductors product is suitable and fit for the customer's applications and products planned, as well as for the planned application and use of customer's third party customer(s). Customers should provide appropriate design and operating safeguards to minimize the risks associated with their applications and products.

NXP Semiconductors does not accept any liability related to any default, damage, costs or problem which is based on any weakness or default in the customer's applications or products, or the application or use by customer's third party customer(s). Customer is responsible for doing all necessary testing for the customer's applications and products using NXP Semiconductors products in order to avoid a default of the applications and the products or of the application or use by customer's third party customer(s). NXP does not accept any liability in this respect.

Limiting values — Stress above one or more limiting values (as defined in the Absolute Maximum Ratings System of IEC 60134) will cause permanent damage to the device. Limiting values are stress ratings only and (proper) operation of the device at these or any other conditions above those given in the Recommended operating conditions section (if present) or the Characteristics sections of this document is not warranted. Constant or repeated exposure to limiting values will permanently and irreversibly affect the quality and reliability of the device.

Terms and conditions of commercial sale — NXP Semiconductors products are sold subject to the general terms and conditions of commercial sale, as published at <https://www.nxp.com/profile/terms>, unless otherwise agreed in a valid written individual agreement. In case an individual agreement is concluded only the terms and conditions of the respective agreement shall apply. NXP Semiconductors hereby expressly objects to applying the customer's general terms and conditions with regard to the purchase of NXP Semiconductors products by customer.

No offer to sell or license — Nothing in this document may be interpreted or construed as an offer to sell products that is open for acceptance or the grant, conveyance or implication of any license under any copyrights, patents or other industrial or intellectual property rights.

Suitability for use in automotive applications — This NXP product has been qualified for use in automotive applications. If this product is used by customer in the development of, or for incorporation into, products or services (a) used in safety critical applications or (b) in which failure could lead to death, personal injury, or severe physical or environmental damage (such products and services hereinafter referred to as “Critical Applications”), then customer makes the ultimate design decisions regarding its products and is solely responsible for compliance with all legal, regulatory, safety, and security related requirements concerning its products, regardless of any information or support that may be provided by NXP. As such, customer assumes all risk related to use of any products in Critical Applications and NXP and its suppliers shall not be liable for any such use by customer. Accordingly, customer will indemnify and hold NXP harmless from any claims, liabilities, damages and associated costs and expenses (including attorneys’ fees) that NXP may incur related to customer’s incorporation of any product in a Critical Application.

Quick reference data — The Quick reference data is an extract of the product data given in the Limiting values and Characteristics sections of this document, and as such is not complete, exhaustive or legally binding.

Export control — This document as well as the item(s) described herein may be subject to export control regulations. Export might require a prior authorization from competent authorities.

HTML publications — An HTML version, if available, of this document is provided as a courtesy. Definitive information is contained in the applicable document in PDF format. If there is a discrepancy between the HTML document and the PDF document, the PDF document has priority.

Translations — A non-English (translated) version of a document, including the legal information in that document, is for reference only. The English version shall prevail in case of any discrepancy between the translated and English versions.

Security — Customer understands that all NXP products may be subject to unidentified vulnerabilities or may support established security standards or specifications with known limitations. Customer is responsible for the design and operation of its applications and products throughout their lifecycles to reduce the effect of these vulnerabilities on customer’s applications and products. Customer’s responsibility also extends to other open and/or proprietary technologies supported by NXP products for use in customer’s applications. NXP accepts no liability for any vulnerability. Customer should regularly check security updates from NXP and follow up appropriately. Customer shall select products with security features that best meet rules, regulations, and standards of the intended application and make the ultimate design decisions regarding its products and is solely responsible for compliance with all legal, regulatory, and security related requirements concerning its products, regardless of any information or support that may be provided by NXP.

NXP has a Product Security Incident Response Team (PSIRT) (reachable at PSIRT@nxp.com) that manages the investigation, reporting, and solution release to security vulnerabilities of NXP products.

NXP B.V. — NXP B.V. is not an operating company and it does not distribute or sell products.

Trademarks

Notice: All referenced brands, product names, service names, and trademarks are the property of their respective owners.

NXP — wordmark and logo are trademarks of NXP B.V.



Contents

1	General description	1
2	Features and benefits	1
2.1	General	1
2.2	Predictable and fail-safe behavior	2
2.3	Low-power management	2
2.4	Protection	2
2.5	TJA1044 CAN FD (applicable to all product variants except TJA1044T)	2
3	Quick reference data	3
4	Ordering information	3
5	Block diagram	4
6	Pinning information	5
6.1	Pinning	5
6.2	Pin description	5
7	Functional description	6
7.1	Operating modes	6
7.1.1	Normal mode	6
7.1.2	Standby mode	6
7.2	Remote wake-up (via the CAN bus)	6
7.3	Fail-safe features	7
7.3.1	TXD dominant time-out function	7
7.3.2	Internal biasing of TXD and STB input pins	7
7.3.3	Undervoltage detection on pins VCC and VIO	7
7.3.4	Overtemperature protection	8
7.4	VIO supply pin (TJA1044GT(K)/3 and TJA1044BT(K) variants)	8
8	Limiting values	9
9	Thermal characteristics	10
10	Static characteristics	10
11	Dynamic characteristics	14
12	Application information	16
12.1	Application diagrams	16
12.2	Application hints	16
13	Test information	17
13.1	Quality information	17
14	Package outline	18
15	Handling information	20
16	Soldering of SMD packages	20
16.1	Introduction to soldering	
16.2	Wave and reflow soldering	
16.3	Wave soldering	
16.4	Reflow soldering	
17	Appendix: ISO 11898-2:2024 parameter cross-reference lists	23
18	Revision history	26
	Legal information	27







Please be aware that important notices concerning this document and the product(s) described herein, have been included in section 'Legal information'.

Looking for pricing, stock, or lifecycle information?

Click below to explore more details on WIN SOURCE:

-  [View TJA1044BTK/0J on WIN SOURCE](#)
-  [NXP / Nexperia Information](#)

Optimize Your Supply Chain with WIN SOURCE Solutions

-  Global Sourcing Solution
-  Obsolete Management
-  Cost Control Management
-  Shortage Management
-  Alternative Solution
-  Excess Inventory Management