

LOC		DIST		REVISIONS			
GP	00	REV	DATE	BY	CHK	APP	REV
C		REVISED PER ECO-08-007327	09APR08	BM	WM		

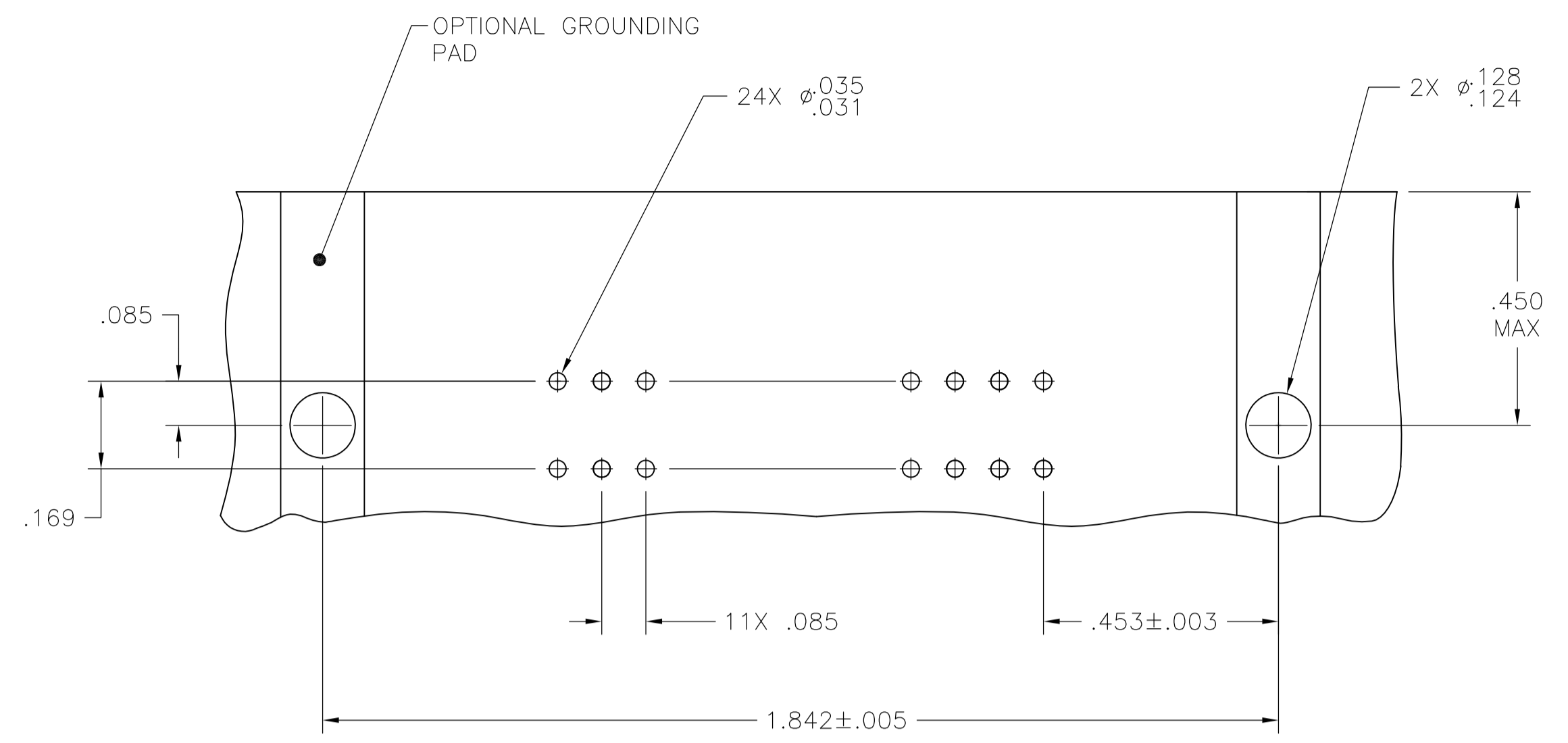

SUGGESTED PRINTED CIRCUIT BOARD MOUNTING DIMENSIONS

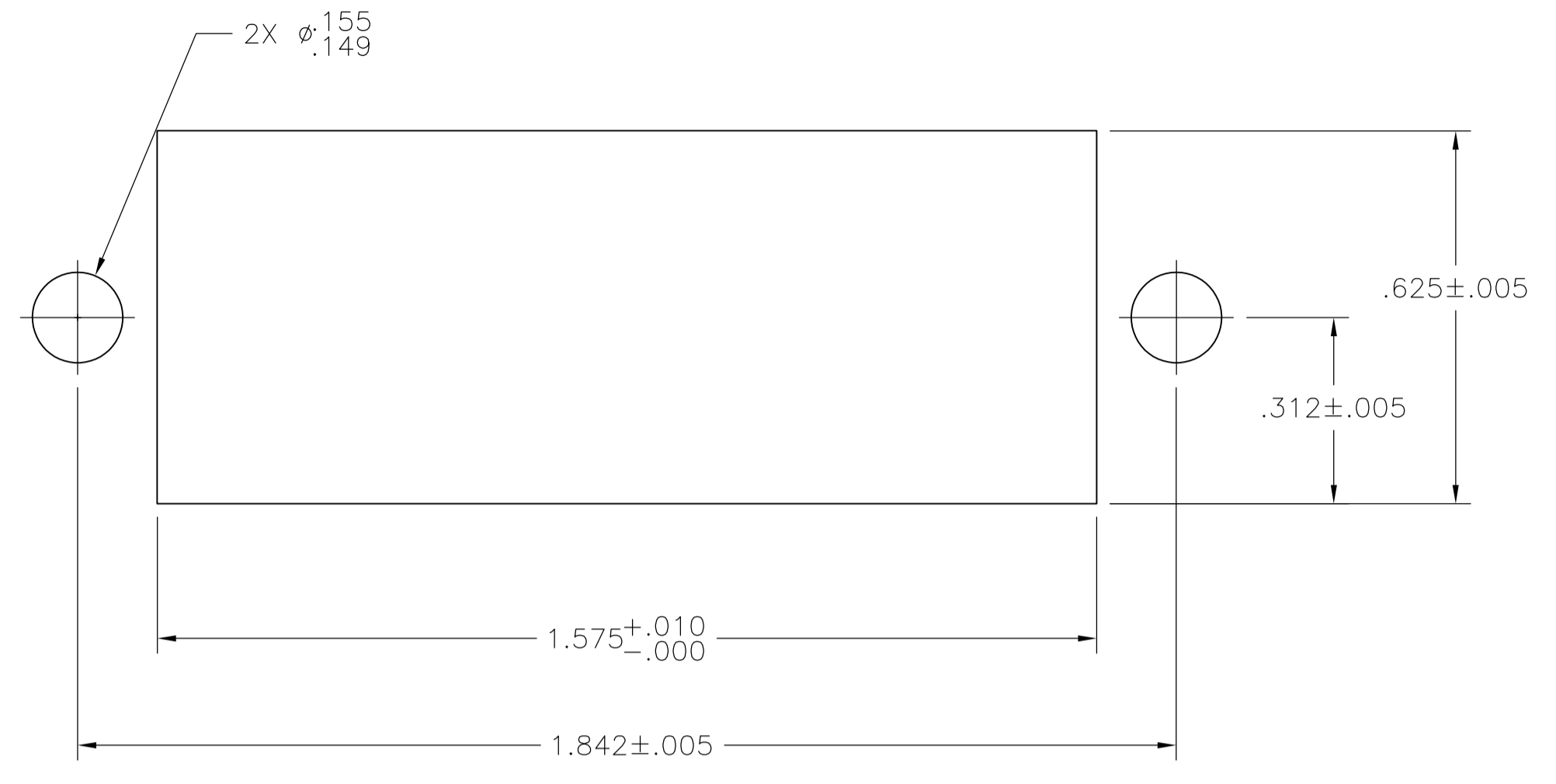

SUGGESTED REAR PANEL MOUNTING CUTOUT DIMENSION

- 1 MATERIAL:  
HOUSING, BRACKET, ADAPTER COMB & TERMINAL SUPPORT PLATE - POLYESTER, BLACK.  
RECEPTACLE SHIELD - BRIGHT NICKEL OVER COPPER PLATED DIE CASTING.  
TERMINALS - HIGH STRENGTH COPPER ALLOY PLATED WITH EITHER .000030 MIN GOLD PLATE OR GOLD FLASH OVER PALLADIUM NICKEL PLATE, .000030 MIN TOTAL ON MATING SURFACE. .000120 MIN TIN PLATE ON TAILS. ALL OVER .000050 MIN NICKEL UNDERPLATE OVER ENTIRE TERMINAL.  
GROUND BRACKET - TIN PLATED CARBON STEEL.
- 2 THE CONTACT SURFACES OF THE TERMINALS ARE COATED WITH CENTRAL LUBRICANT.
- 3 CENTER TO CENTER SPACING OF TERMINALS IS 0.85 NOMINAL.
- 4 ALL DIMENSIONS ARE MAXIMUM UNLESS OTHERWISE SPECIFIED.
- 5 DETAILS "A" & "D" ARE VIEWED FROM MATING SIDE OF THE RECEPTACLE ASSEMBLY.
- 6 SHIELD IS ASSEMBLED TO RECEPTACLE ASSEMBLY BEFORE SHIPMENT.
- 7 TERMINAL 1 IS LOCATED IN THIS ROW FOR REVERSE ORIENTAION, SEE DETAIL A.
- 8 PANEL THICKNESS RANGE 1 .062 MAXIMUM.
- 9 GROUNDING BRACKET RETAINS CONNECTOR IN .062 THICK PC BOARD WITHOUT ADDITIONAL HARDWARE.
- 10 IF TERMINALS DO NOT EXTEND BELOW COMB, THEN COMB SHALL BE PARTIALLY RETRACTED, BEFORE INSERTING CONNECTOR INTO THE PC BOARD.
- 11 GROUNDING BRACKET LOCATES CONNECTOR FLUSH WITH TOP OF PC BOARD AND SPRING LOCKS BENEATH.
- 12 CYLINDRICAL SHAPE OFFERS 180° OF SOLDERING SURFACE.
- 13 SURFACE AREA OF GROUNDING BRACKET BELOW PC BOARD SHALL PASS SOLDERABILITY REQUIREMENTS IN ACCORDANCE WITH AMP SPECIFICATION 109-11-2, DISCOLORATION, SCRATHES, SPOTS AND OTHER COSMETIC DEFICIENCIES TYPICAL OF BARREL PLATING PROCESS ARE ACCEPTABLE PROVIDING PARTS PASS 24 HOUR EXPOSURE AT 95% RH AT 40°C, WITHOUT EVIDENCE OF CORROSION.
- 14 TERMINAL 1 LOCATED IN THIS ROW FOR STANDARD ORIENTAION, SEE DETAIL D.

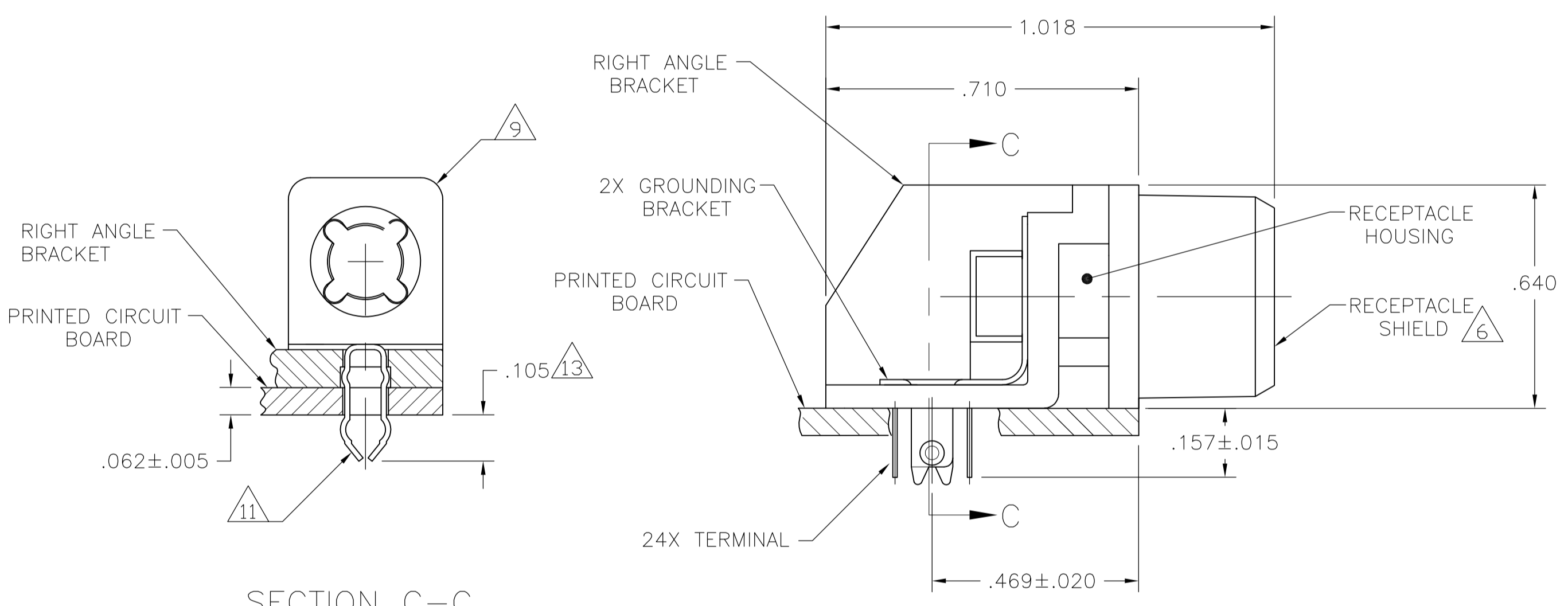

SECTION C-C

REAR PANEL MOUNTING DETAIL SHOWN FOR REFERENCE ONLY

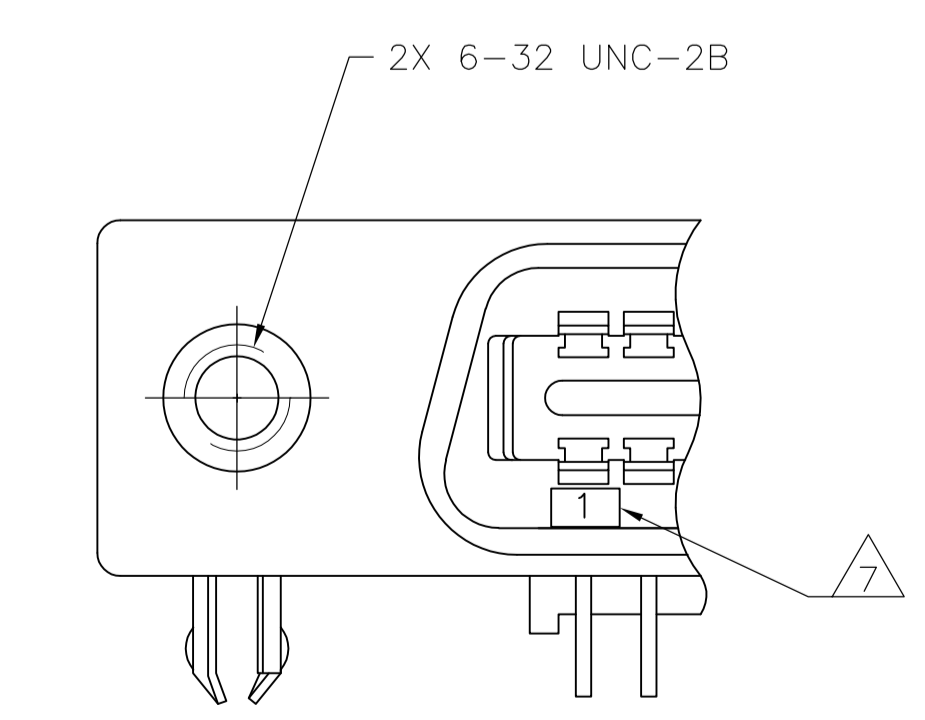
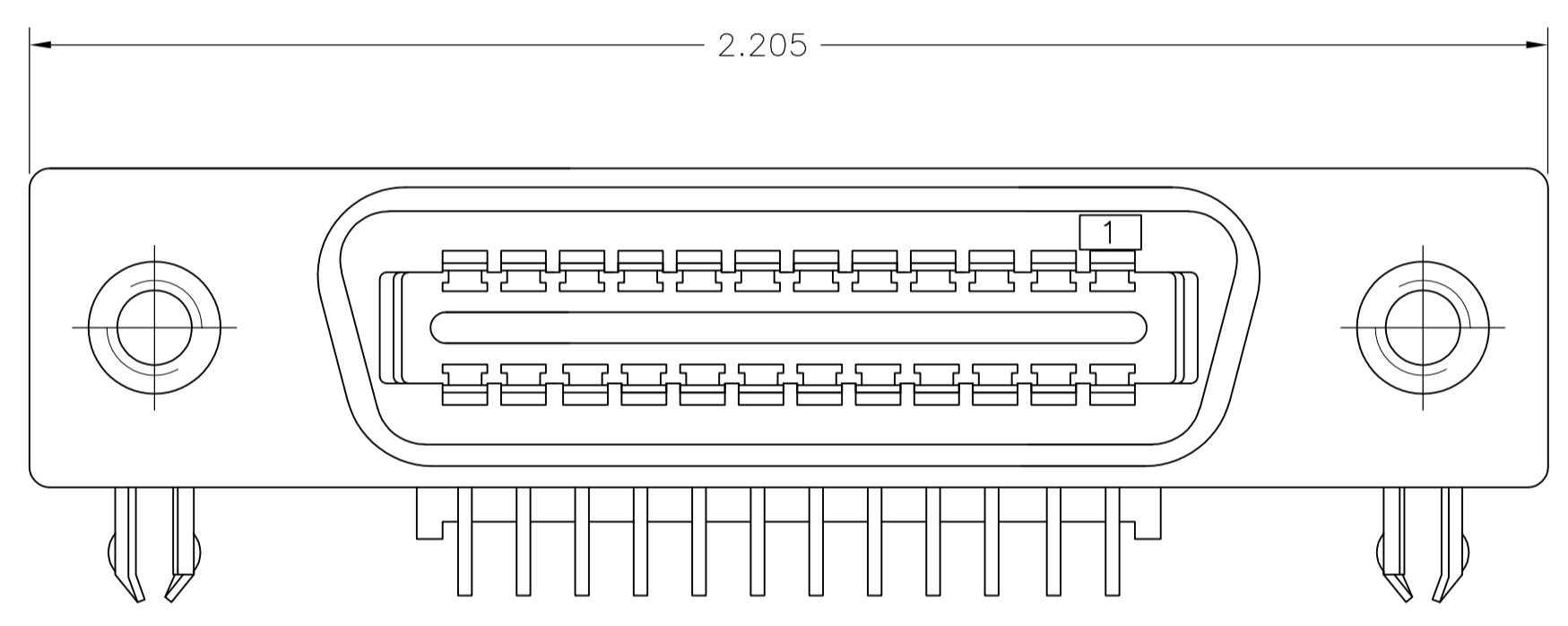

DETAIL A REVERSE ORIENTATION

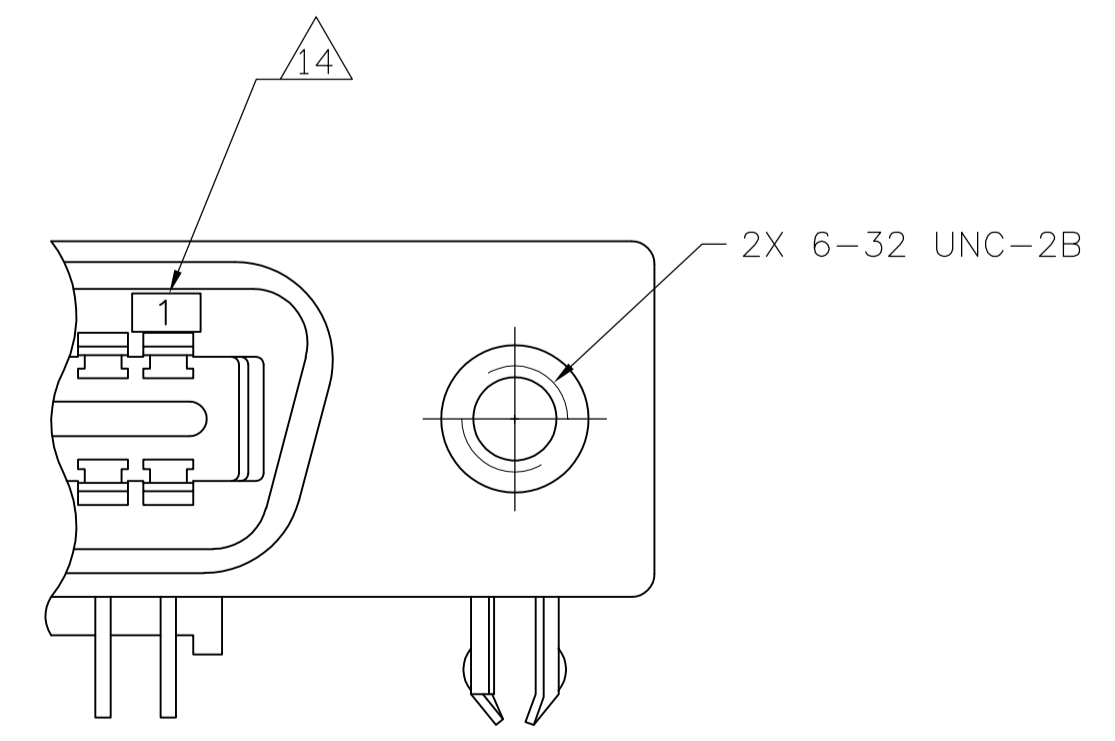

DETAIL D STANDARD ORIENTATION

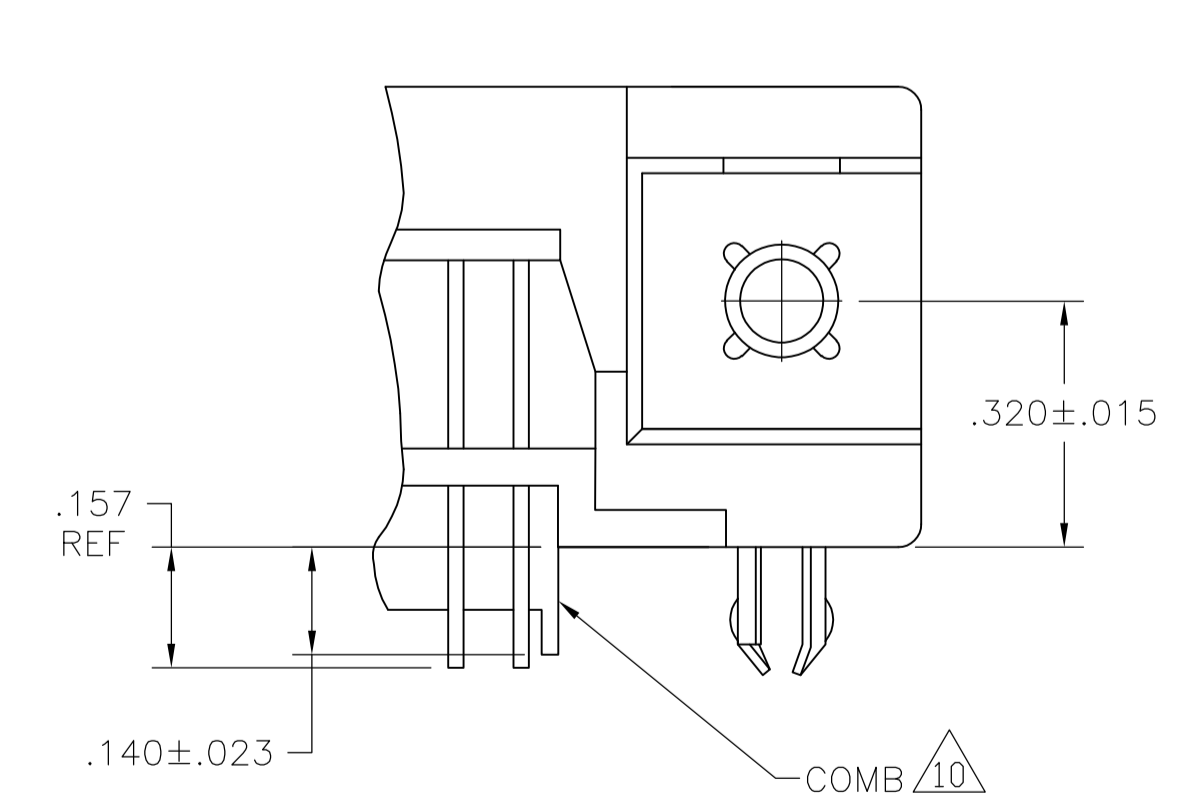

DETAIL B

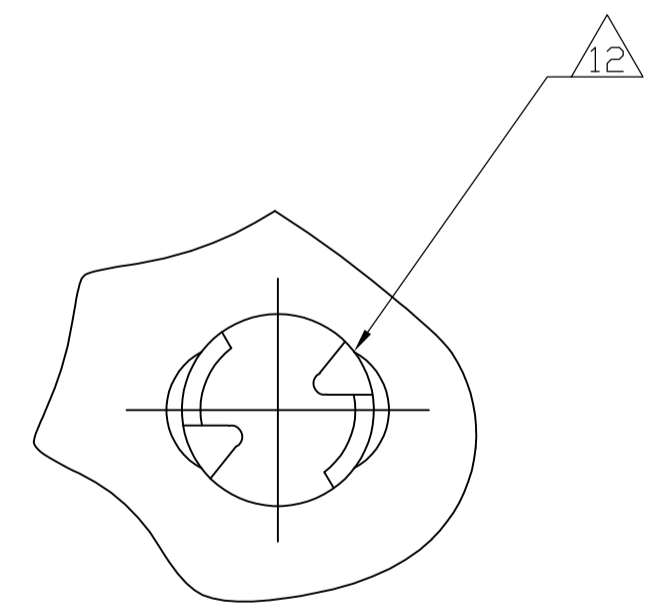

D	STANDARD	5554923-2
A	REVERSE	5554923-1
SEE DETAIL	ORIENTATION	PART NUMBER

THIS DRAWING IS A CONTROLLED DOCUMENT.		DIN B MCMMASTER 28JUN05	Tyco Electronics Corporation Harrisburg, PA 17105-3608	
DIMENSIONS: INCHES		CHK W MILLHIMES 28JUN05	NAME RECEPTACLE ASSEMBLY, 24 POSITION, RIGHT ANGLE, SHIELDED, FLUSH PANEL MOUNTING WITH BOARD LOCK, CHAMP	
TOLERANCES UNLESS OTHERWISE SPECIFIED:		APPD W MILLHIMES 28JUN05	PRODUCT SPEC	
0 PLC	± -	APPLICATION SPEC		
1 PLC	± -	SIZE CAGE CODE DRAWING NO		
2 PLC	± -	A1 00779 C=5554923		
3 PLC	± -	WEIGHT		
4 PLC	± -	CUSTOMER DRAWING		
ANGLES	± -	SCALE 4:1 SHEET 1 OF 1 REV C		
MATERIAL	FINISH			

Looking for pricing, stock, or lifecycle information?

Click below to explore more details on WIN SOURCE:

[View 5554923-1 on WIN SOURCE](#)

[TE Connectivity Information](#)

### Optimize Your Supply Chain with WIN SOURCE Solutions

- ✓ Global Sourcing Solution
- ✓ Obsolete Management
- ✓ Cost Control Management
- ✓ Shortage Management
- ✓ Alternative Solution
- ✓ Excess Inventory Management