

Japan Aviation Electronics Industry, Ltd. Connector Division	No.	J AHL-1594-E				Page 1/13
Title: Handling Manual for MX19 series connector	Rev.	DATE	DCN No.	By	CHKD	APRVD
	1	15, Feb., 00	-	J. Miyamoto	M. Shinmyo	T. Totani
	2	20, Mar., 00	45765	J. Miyamoto	M. Shinmyo	T. Totani
	3	28, Jul., 00	46565	J. Miyamoto	N. Oiri	T. Totani
	4	23, Jul., 09	068385	Y. Obata	-	N. Oiri
Handling Manual						
Originating Dept.:	5	1, Mar., 11	071688	Y. Obata	M. Kuroiwa	N. Oiri
Connector Div. 3rd Engineering Dept.						

## Contents

1. Purpose
2. Applicable Items
3. Crimping
  - 3-1. Applicable Wires
  - 3-2. Stripping length of wire insulators
  - 3-3. Part description
  - 3-4. Criteria for judgment on conforming items
  - 3-5 Criteria for judgment on non-conforming items
  - 3-6 Other cautions for crimping process
4. How to insert
  - 4-1. Contacts
  - 4-2. Dummy Plug
5. How to withdraw contact
6. How to engage/ separate connector
7. Cautionary statement

## 1. Purpose

This document provides the handling on MX19 series connectors.

## 2. Applicable items

### 2.1 Housing

Table2-1 MX19 Connector Housing

Terminals No.	Type	Product Name	Color
2 (Fig.2-1)	Pin Housing	MX19002P51	<b>Black</b>
		MX19002P52	Gray
	Socket Housing	MX19002S51	<b>Black</b>
		MX19002S52	Gray
4 (Fig.2-2)	Pin Housing	MX19004P51	<b>Black</b>
		MX19004P52	Gray
	Socket Housing	MX19004S51	<b>Black</b>
		MX19004S52	Gray

### 2.2 Contacts and Dummy plug

Table2-2 MX19 Contacts and Dummy plug

Type	Product Name	NOTE	
Pin contact	MX19P10K451	Sn plating	Fig.2-3
Socket contact	MX19S10K451	Sn plating	Fig.2-4
Dummy plug	MX19000XD1	Color: Natural White	Fig.2-5

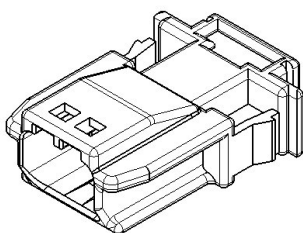

MX19002P5\*

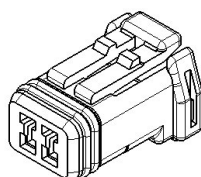

MX19002S5\*

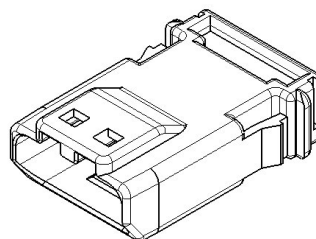

MX19004P5\*

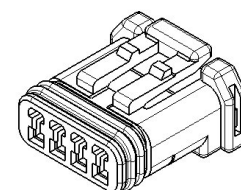

MX19004S5\*

Fig.2-1 MX19 2-terminals type.

Fig.2-2 MX19 4-terminals type.

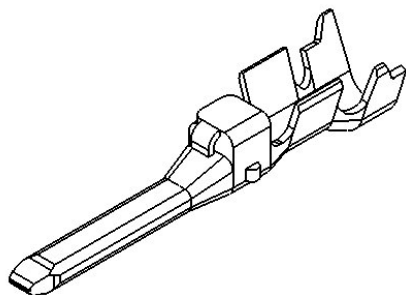

Fig.2-3 Pin contact.

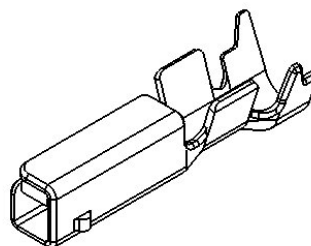

Fig.2-4 Socket contact.

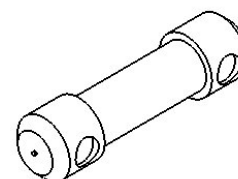

Fig.2-5 Dummy plug.

### 3. Crimping

JAE's applicator is described on the following table.

Table3-1 JAE Crimping Applicator

Type	Automatic Applicator	Semi-automatic Applicator
Product Name	350-MX19-3B	350-MX19-2

#### 3.1 Applicable Wires

Table3-2 Applicable Wire for MX19 connector

Applicable Wire Type	Conductor construction (No./Shape or size)	Calc. Conductor of cross-section [ mm <sup>2</sup> ]	Wire Insulator [mm]
CAVS0.3mm <sup>2</sup>	7/ Round Compressed	0.3717	φ 1.4 ~1.5
CPTL 22	7/ φ 0.13	0.3717	φ 1.57 (Reference Information)
CAVS0.5 mm <sup>2</sup>	7/ Round Compressed	0.5630	φ 1.6 ~1.7
AVSS0.5 mm <sup>2</sup>	7/ φ 0.13	0.5630	φ 1.6 ~1.7

#### 3.2 Striping length of wire insulators

Check the stripping length of wire insulators( refer to Fig.3-2.) On the wire treatment, must check the damaged insulator, damaged, missing and/ or disordered conductor (refer to Fig. 3-1.)

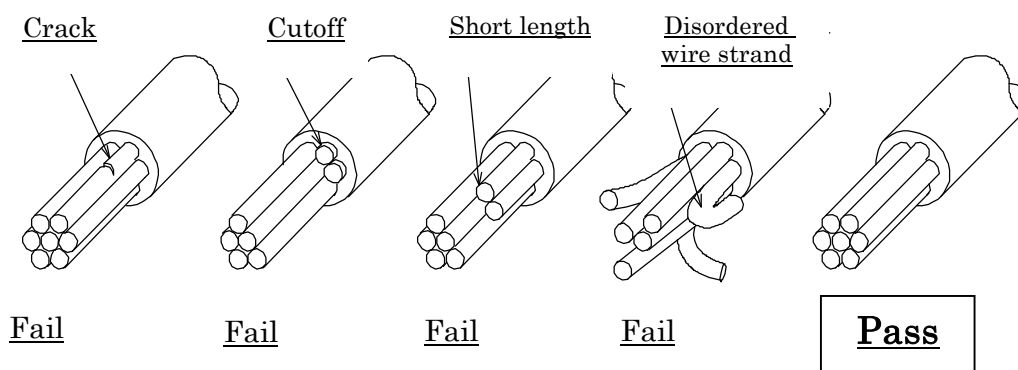
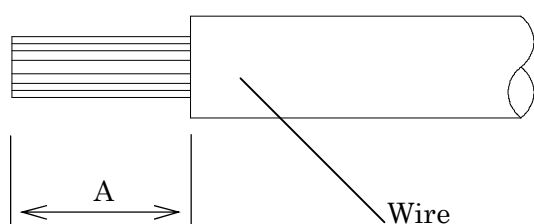

Fig. 3-1 Defective wire treatment for crimping.



Contact Name	Length A [mm]
MX19P10K451	2 ~2.5mm
MX19S10K451	

Fig. 3-2 Striping length for MX19 contact crimping

### 3.3 Part description

#### 3.3.1 Pin Contact

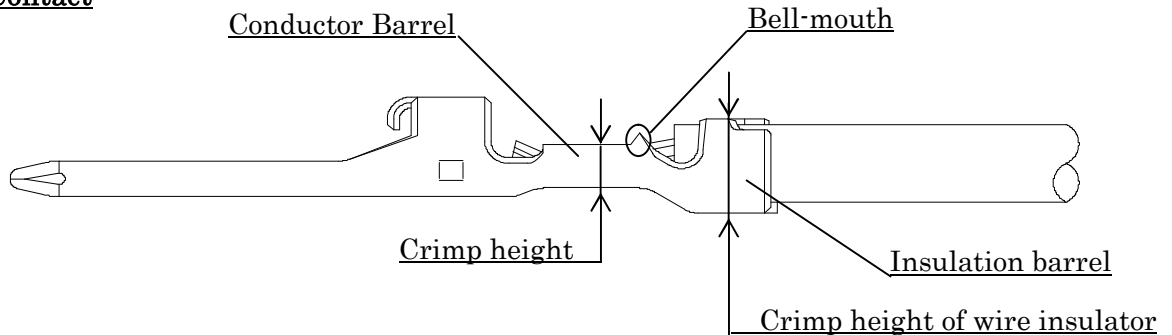

Fig.3-3 Part description of pin contact

#### 3.3.2 Socket contact

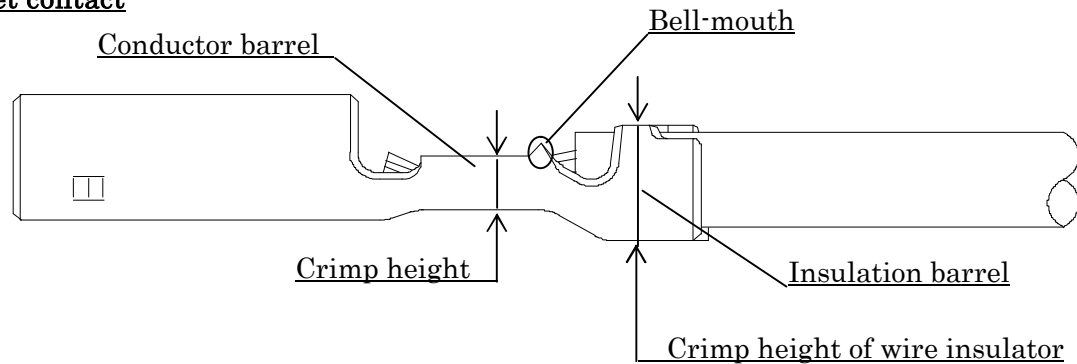

Fig.3-4 Part description of Socket contact

### 3.4 Criteria for conformed crimping items **▲ ▲**

"Properly crimped contact" is as follows:

1. Meet the crimp height shown in **Table 3-3**.
2. The "Bell-mouth" (no crimping on conductor) is attached.
3. The tip of conductor stick out 0.5mm( or less) from "Conductor Barrel."
4. All conductor of wire is within the "Conductor Barrel".
5. Any wire insulator is **NOT crimped** into "Conductor Barrel."
6. No cracks and/ or burrs etc. is in crimping area.

Table3-3 Appropriate Crimp Height

Wire Type	Crimp Height [mm]	Crimp wide (Ref.)[mm]	Crimp height of wire insulator [mm]
CAVS0.3mm <sup>2</sup>	0.73~0.83	1.48~1.54	1.6~1.7
CPTL 22	0.73~0.83	1.48~1.54	1.7~1.9
CAVS0.5 mm <sup>2</sup>	0.75~0.85	1.52~1.58	1.7~1.9
AVSS0.5 mm <sup>2</sup>	0.75~0.85	1.52~1.58	1.7~1.9

**NOTE 1:** Crimp height dimension is fabricated by JAE's applicator.

**NOTE 2:** Crimp width/ height and crimp height of wire insulators are reference values only.

### 3.4 Criteria for judgment on non-conforming items △△

If a crimped MX19 contact has any following defective item, the crimping work is failure. DON'T use the failure crimping contact.

Table3-4 Defective Items for Crimping Work

No.	Defective Item	Example
1	<p><b><u>Incomplete wire insertion</u></b> Not fully inserted conductor(s) into "Crimp Barrel."</p>	 <p>Wire core</p>
2	<p><b><u>Shortage of wire stripping</u></b> Inserted the wire insulator into "Crimp Barrel."</p>	 <p>Wire insulator is in "Crimp Barrel."</p>
3	<p><b><u>Extrusion wire strand(s)</u></b> Conductor(s) on the OUTSIDE of "Crimp Barrel."</p>	 <p>Extrusion of conductor(s)</p>
4	<p><b><u>Failure treatment of wire stripping (too longer).</u></b> △</p> <p>Not completely inserted wire insulator into "Insulation Barrel." (Dimension "D" over 0.3mm.)</p> <p>Over inserted( Dimension "E") the conductor(s) into Box. (Dimension "E" over 0.7mm from the conductor barrel end.)</p>	 <p>Incompletely inserted of wire insulation</p> <p>Over inserted of conductor</p>

Table3-4 Defective Items for Crimping Work

No.	Defective Item	Example
5	<p><b><u>Inclined Insulator Barrel</u></b> The incline over 0.3mm at any side.</p>	
6	<p><b><u>Bended( On axis)</u></b> The angle "P" over 3 degrees, between crimping parts axis.</p>	
7	<p><b><u>Twisted</u></b> The angle of center of conductor barrel to insulator barrel center has over 2.5 degrees.</p>	
8	<p><b><u>Burr after cut off the carrier</u></b> The burr after the cut off is over 0.2mm.</p>	
9	<p><b><u>Without Bell-mouth</u></b> Failure of crimping, "Bell-mouth" is not formed.</p>	
10	<p><b><u>Deformed of Insulator Barrel</u></b> The deformation has the gap between insulator barrel over 0.3mm.</p>	

Table3-4 Defective Items for Crimping Work

No.	Defective Item	Example
11	<p><b><u>Bend up/ down</u></b>                      “Bend up(or down)” is based on the crimp barrel area.</p> <p>Failure case is dimension Y1 (or Y2) is over C1( or C2).</p> <p>Y<sub>1</sub> (or Y<sub>2</sub>): Pin contact’s Bend up (or down)                      C<sub>1</sub>( or C<sub>2</sub>): Socket contact’s Bend up( or down)</p>	 <p>a. Bend-up(Pin contact)</p> <p>b. Bend-down(Pin contact) <b>Fig. Pin contact</b></p> <p>a. Bend-up(Socket contact)</p> <p>b. Bend-down(Socket contact) <b>Fig. Socket contact</b></p>
12	<p><b><u>End-face deformation</u></b>                      If you find a contact deformation (H<sub>1~4</sub>) of following, as shown in right figures, never use such as a crimped contact.                      Check and adjust( or repair) a crimping machine( or a device.)                      In the case of a deformation is within 0.15mm but having dimensions F<sub>1~4</sub> over 0.05 on a side, the crimping work is failed.</p> <p>F<sub>1~4</sub> &gt; 0.05mm                      H<sub>1~4</sub> &gt; 0.15mm</p>	 <p>Pin Contact</p> <p>Socket Contact Deformation of contact rear end</p>

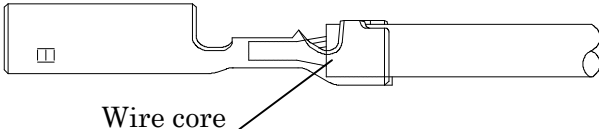
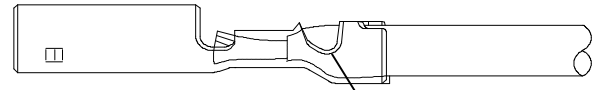
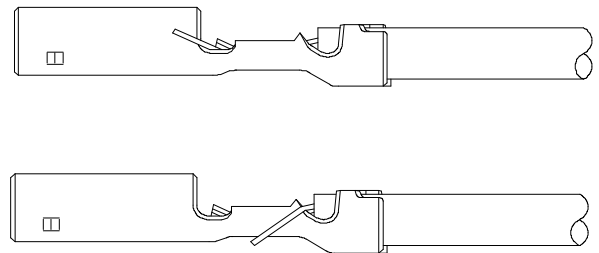
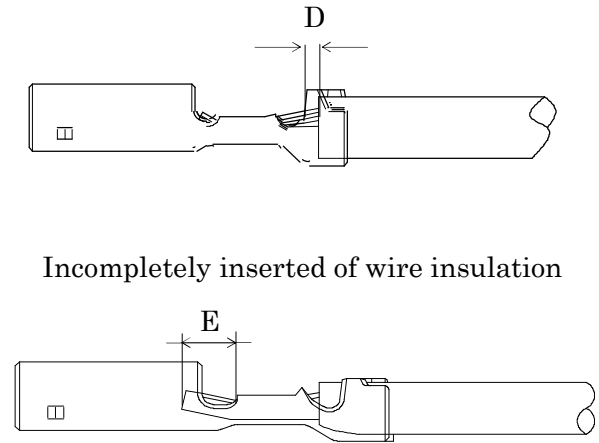
**4. Contact/ Dummy Plug Insertion** ⚠ ⚠

**4.1 Contact Insertion**

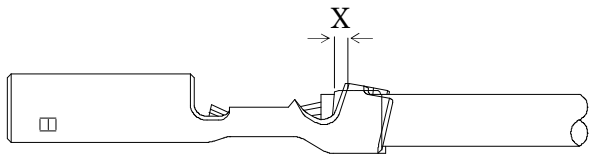
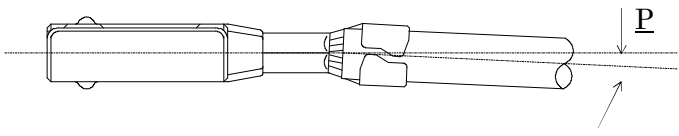
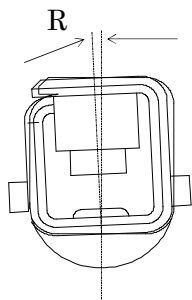
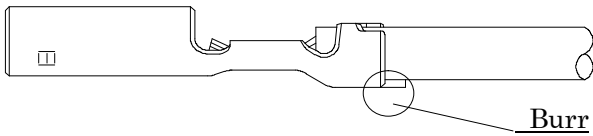
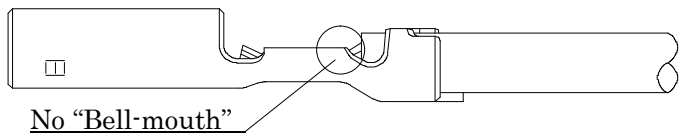
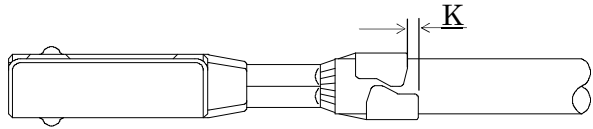
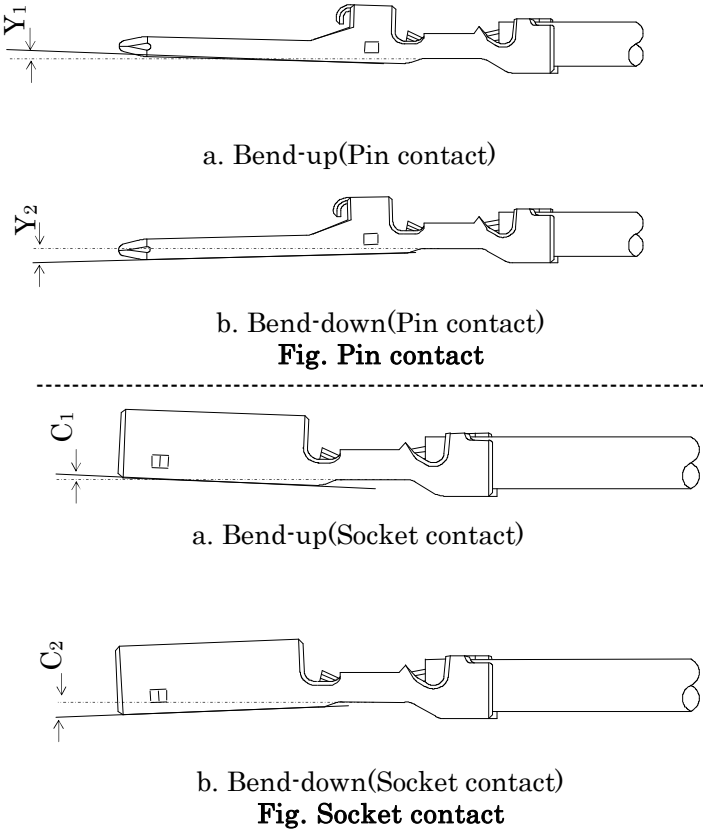
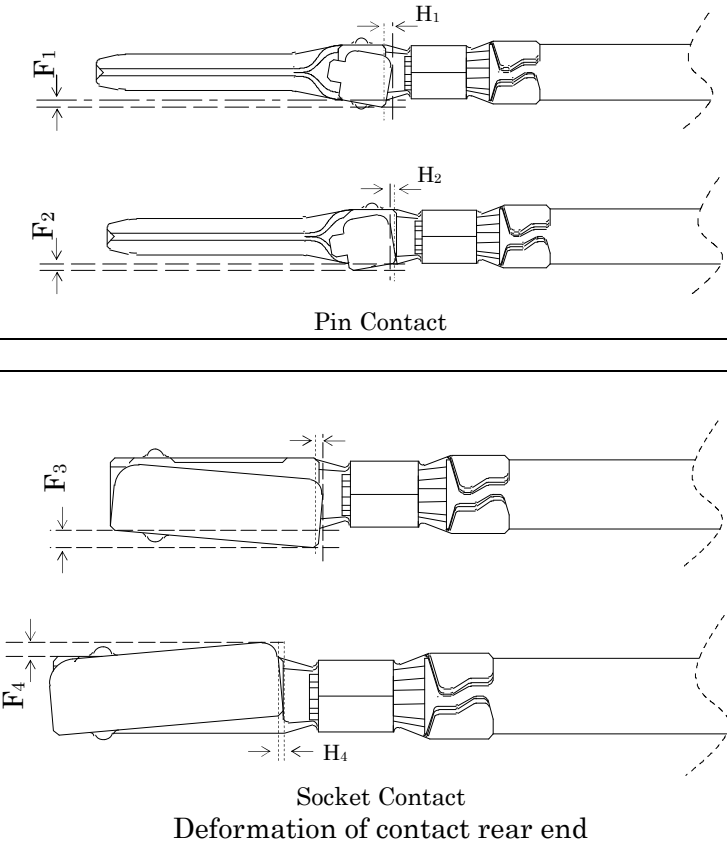
1. Visual inspection, the connector has no breakage, deformation, discoloration, and/or damage etc.
2. Aligned the axis and direction between a contact and a cavity.
3. Handling the wire of the near position of contact for not to be occurred bending.
4. Contact insertion is completely done until the terminal locking part sounded.

(Check the terminal insertion by pulling the wire with little force.)

NOTE: If the contact insertion is tight or incapable, DON'T force to insert, check the direction of contact.  
Tight(or incapable) insertion will cause a contact deformation, crack and/or disconnection.

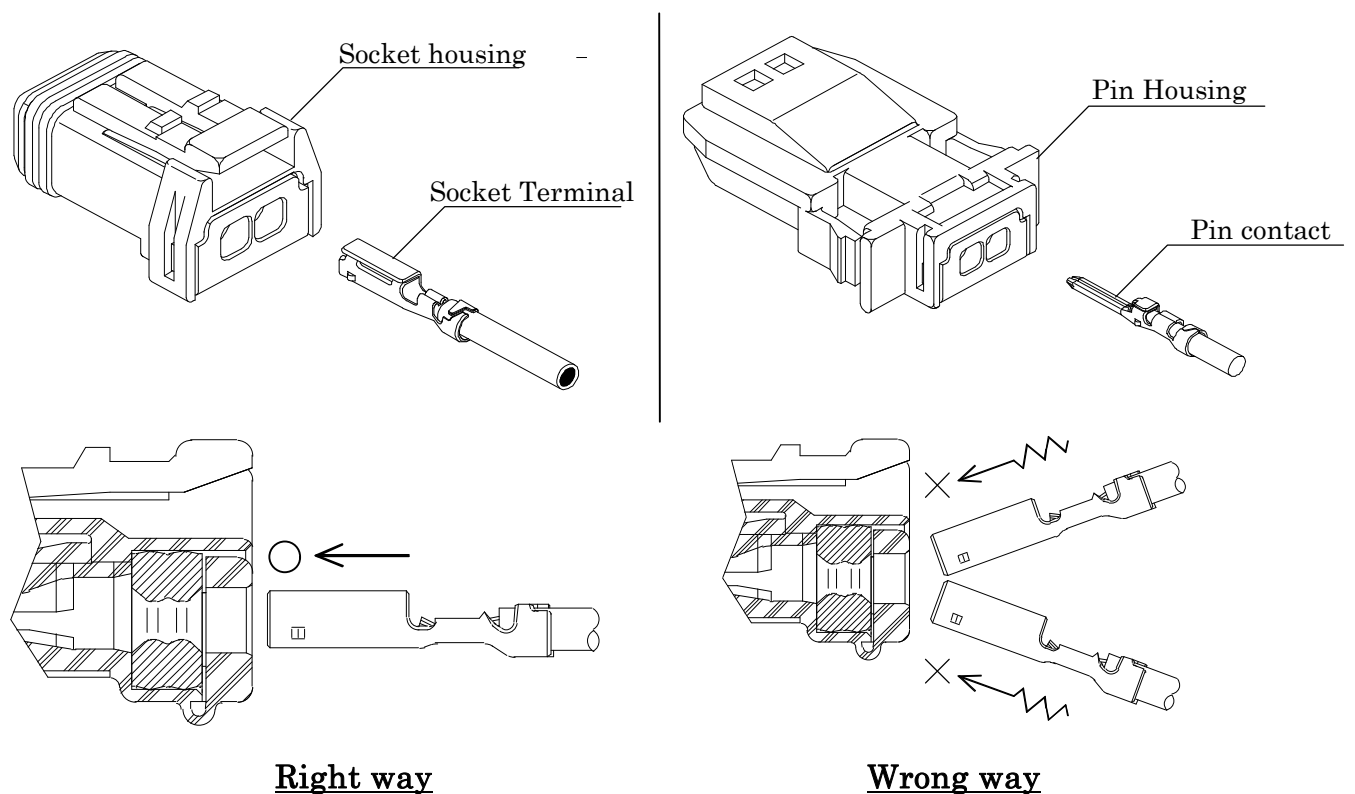

Fig.4-1 Contact insertion

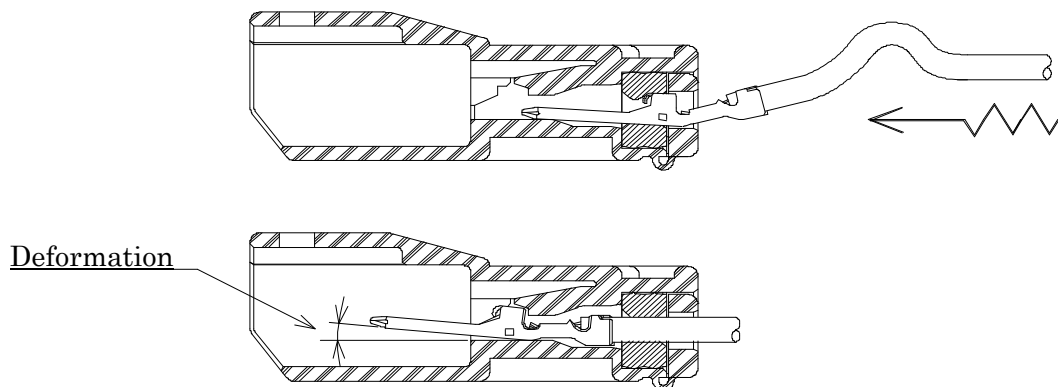

Fig.4-2 Example, contact deformation by wrong contact insertion.

#### 4.2 Dummy Plug Insertion

1. Check by visual inspection, the connector has no breakage, deformation, discoloration, and/or damage etc.
2. Aligned the axis between a dummy plug and a cavity.
3. Inserting a dummy plug into cavity, insertion is the end-face of dummy-plug by connector's.  
Acceptance Criteria: Base on the housing end-face, Dummy plug's end-face is within 0 +0.5/-0.5mm.

NOTE: DON'T apply unnecessary force to on inserting dummy plug.

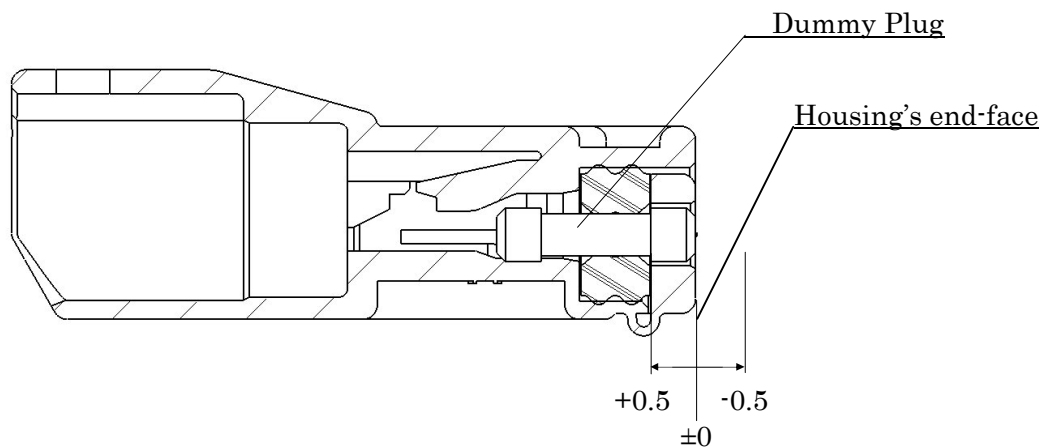

Fig.4-3 Dummy Plug insertion

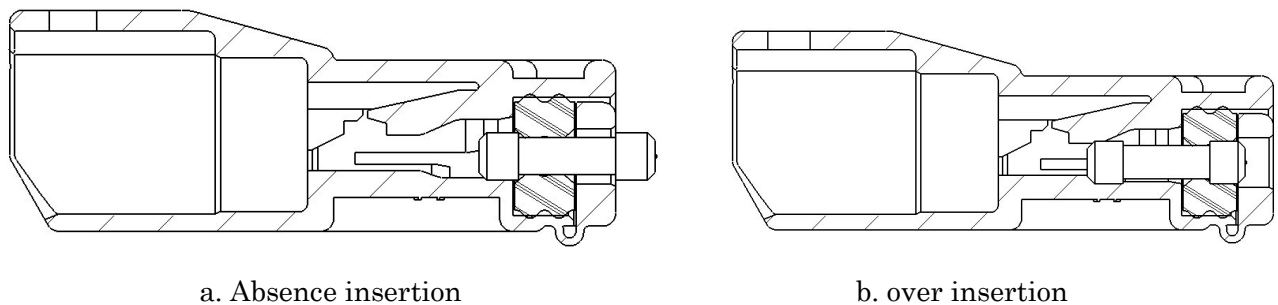

Fig.4-4 Failure dummy plug insertion

### 5. Contact withdraw

1. Visual inspection, the connector has no breakage, deformation, discoloration, and/or damage etc.
2. Pushing lightly the wire with crimping contact and keeping.
3. Inserting a “Withdrawing Tool” into a tool cavity, as following Fig.6-2 and Fig.6-3.
4. When the toe of withdrawing tool met the molding lance, release contact locking. And keeping.
5. Withdrawing the wire on straight axis.

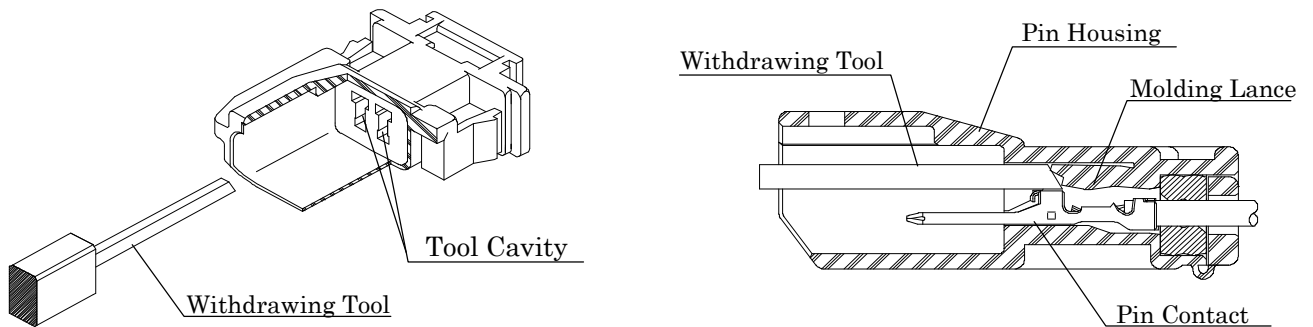

Fig.5-1 Pin Contact Withdraw

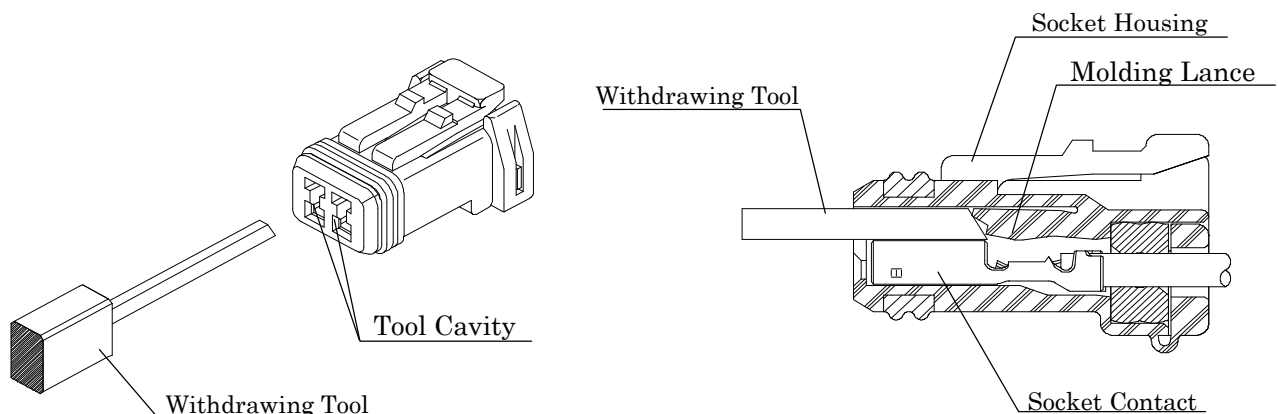
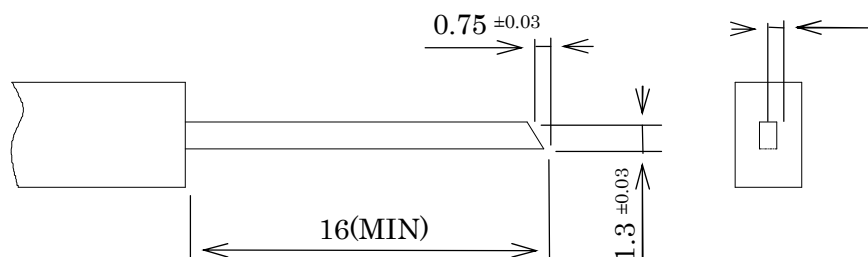

Fig.5-2 Socket Contact Withdraw

NOTE: Suitable dimension for withdrawing tool( JAE’s withdrawing tool is “ET-MX19.”)



NOTE: DON’T snag a contact on grommet by forcedly withdrawing.

NOTE: The limitation frequency for withdrawing at one cavity is 3 times. If you find any damage and deformation, DON’T use it, change to the new one.

NOTE: DON’T apply unnecessary force on withdrawing.

NOTE: Withdrawing tool insertion is only a “tool cavity,” never inserting the contact cavity.

## **6. How to engage connector**

### **6.1 Engaging**

1. Check the contact insertion.
2. Check by visual inspection, the connector has no breakage, deformation, discoloration, and/or damage etc. in contacts and housing.
3. Aligned the direction with the engagement aperture.
4. Insert the connector into the housing until the lock parts sounded.

NOTE: DON'T apply unnecessary force to connector on inserting/separating connector.

NOTE: If housings insertion is tight or incapable, DON'T force to insert, check the direction of contact.  
Tight( or incapable) insertion will cause a connector deformation, crack and/or disconnection.

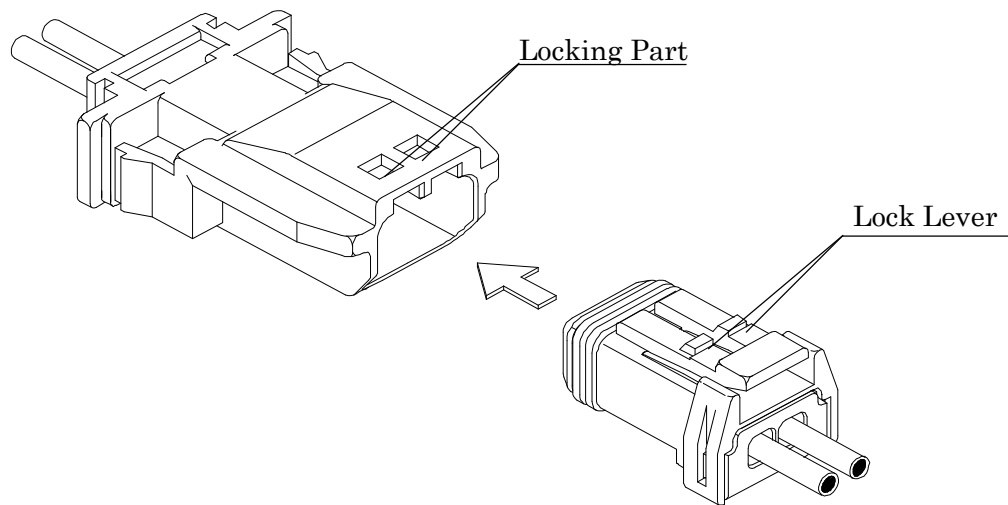

Fig.6-1 Connector insertion

## **6.2 Connector Separation Method**

Hold a Socket Housing, and pull out the connector straightly;

- 1: Depressing the lock arm of socket housing.
- 2: Releasing the engagement lock.

NOTE: On separating the connector, DON'T pulling only wires and prying the connector.

NOTE: In case of incapable of separation, DON'T force it to pull out.

Check the engagement lock is released.

NOTE: DON'T apply unnecessary force to connector on inserting/separating connector.

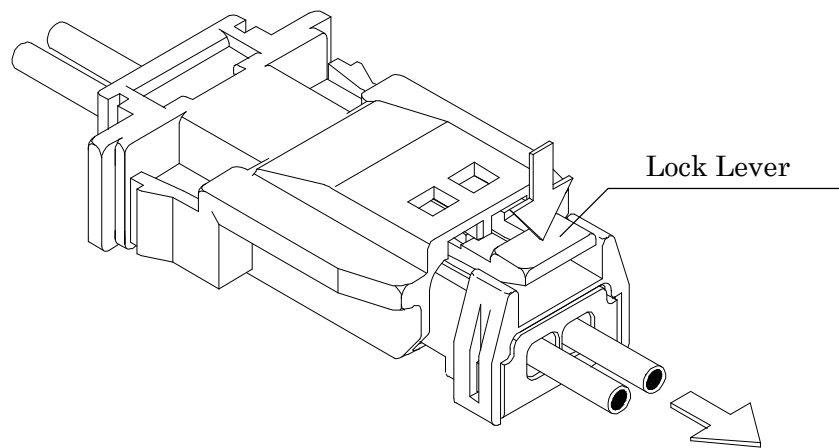

Fig.6-2 Connector separation

## 7. Cautionary Statements



# Caution

---

**Comply strictly with the following matters because of possibility of physical damage and/or connector failures.**

- Perform the engagement of connector straightly until the "click" sound.
- Be careful not to slide and/or pinch your fingers accidentally because some force may be applied to your fingers at the time of connector insertion/withdrawal. Moreover, DON'T pull a cable at the time of withdrawal.
- DON'T touch the contact area, or adhere any foreign materials on.
- When withdrawing a contact from the connector, be sure to use an exclusive tool.
- Exercise care to avoid injuring at the time of cable treatment, pre-mounting, soldering and using other tools.
- Care must be taken to prevent excessive current (over load) as this might be cause overheating and fire.
- DON'T disassemble each component of housing.
- DON'T insert anything other than the specified contacts to housing.
- For handling on connectors and contacts, comply with the provisions in this document. Unreasonable handling is not permissible.

## Looking for pricing, stock, or lifecycle information?

Click below to explore more details on WIN SOURCE:

 [View MX19002S51 on WIN SOURCE](#)

 [JAE Electronics Information](#)

## Optimize Your Supply Chain with WIN SOURCE Solutions

-  Global Sourcing Solution
-  Obsolete Management
-  Cost Control Management
-  Shortage Management
-  Alternative Solution
-  Excess Inventory Management