

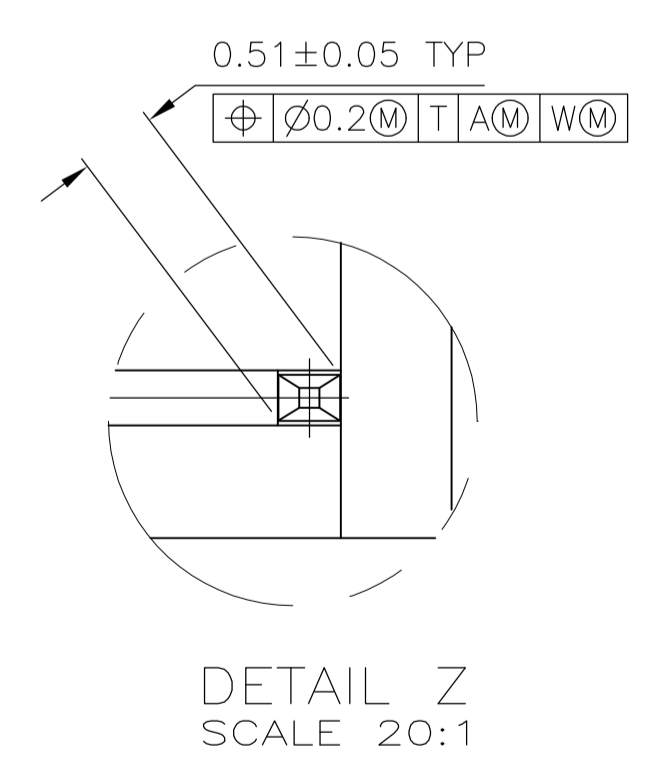

**THE DATASHEET OF**  
**5536613-1**

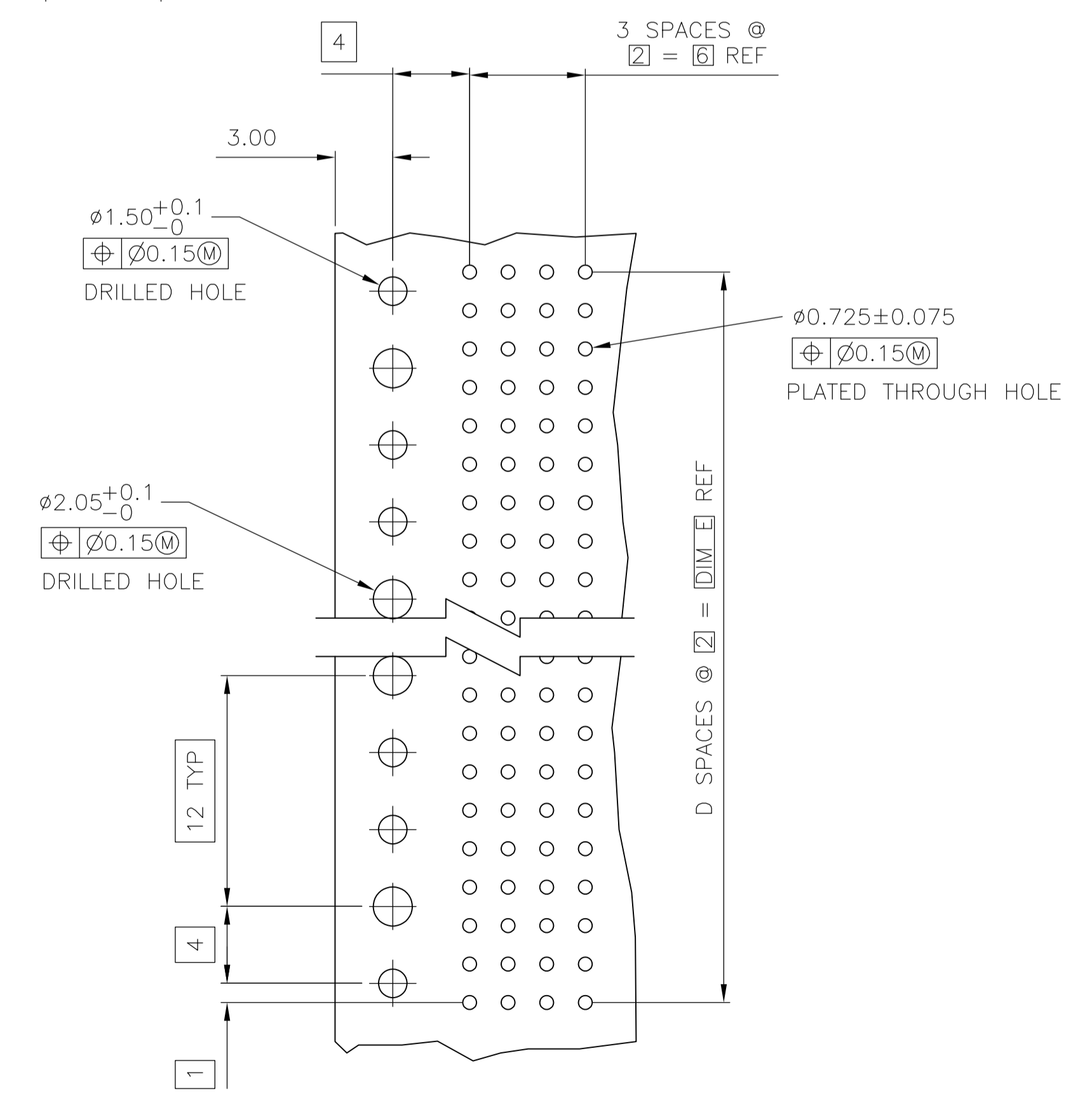

LOC		DIST		REVISIONS			
P	LTR	DESCRIPTION	DATE	DMN	APVD		
A3		REVISED PER ECO-11-004835	11MAR11	RK	HMR		

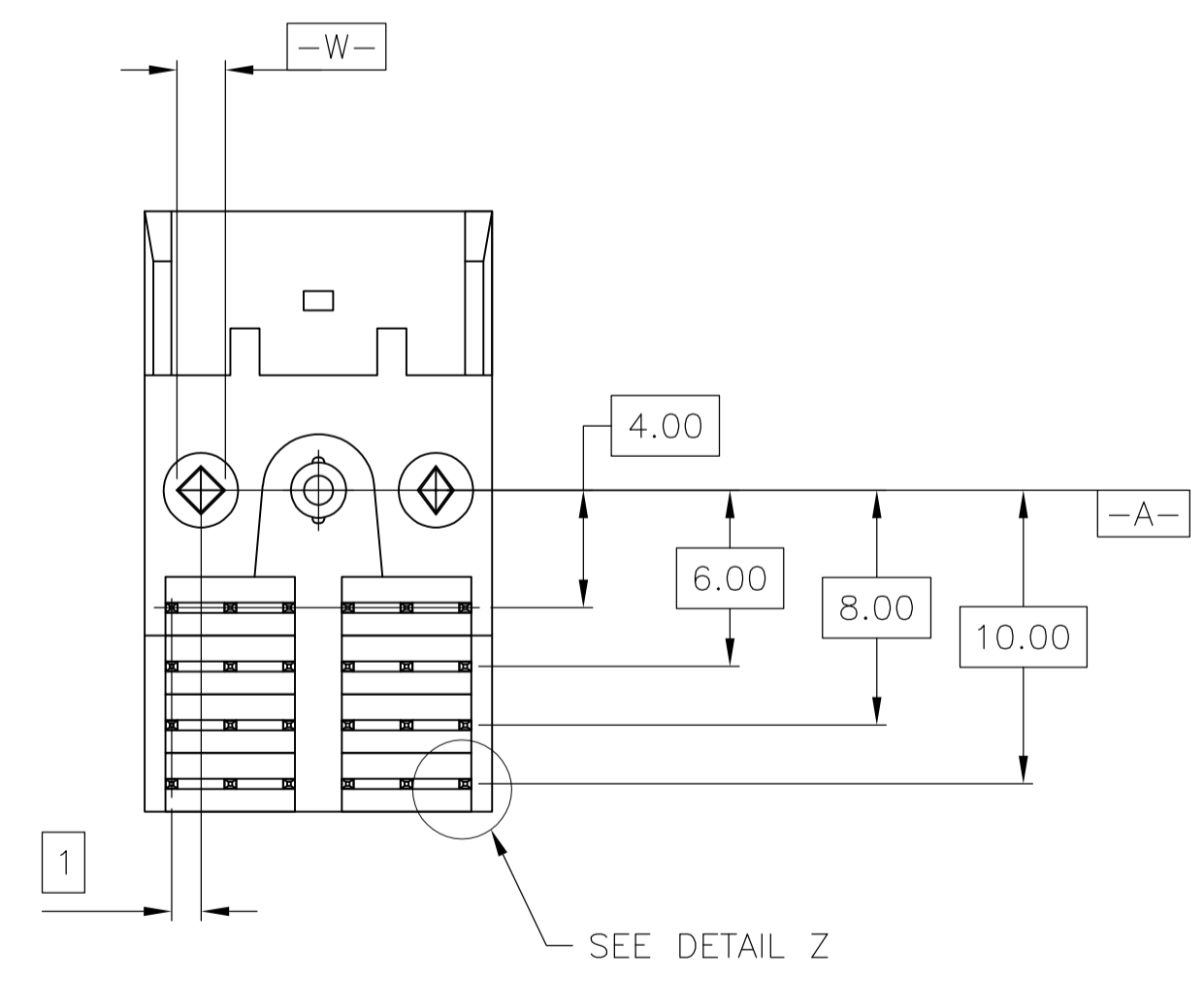
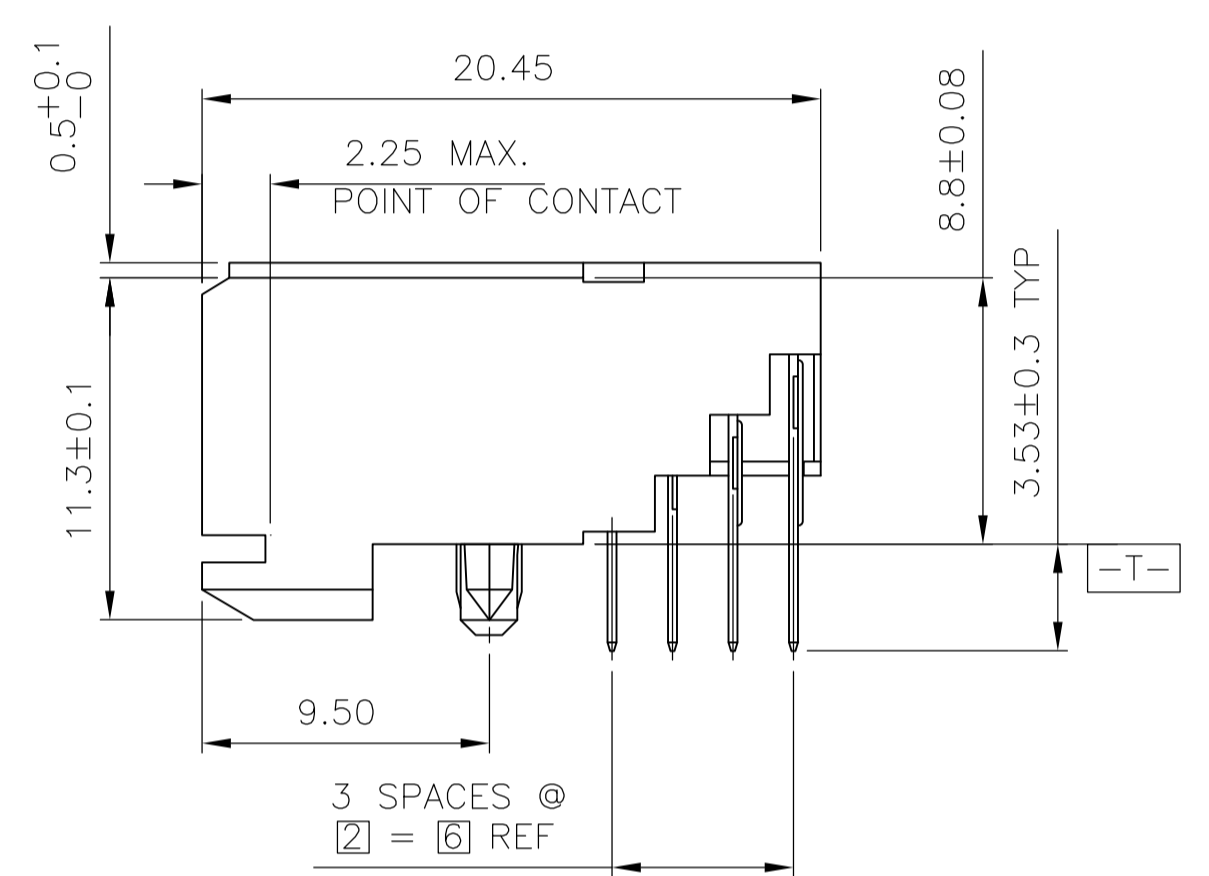
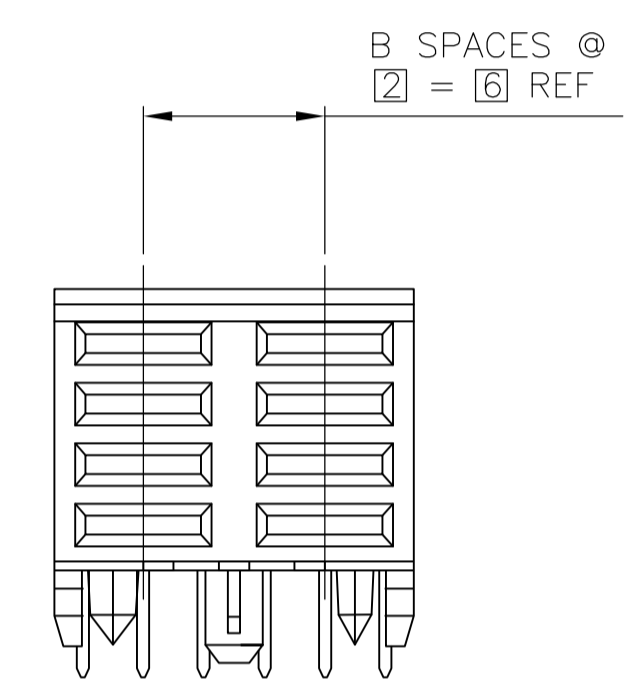
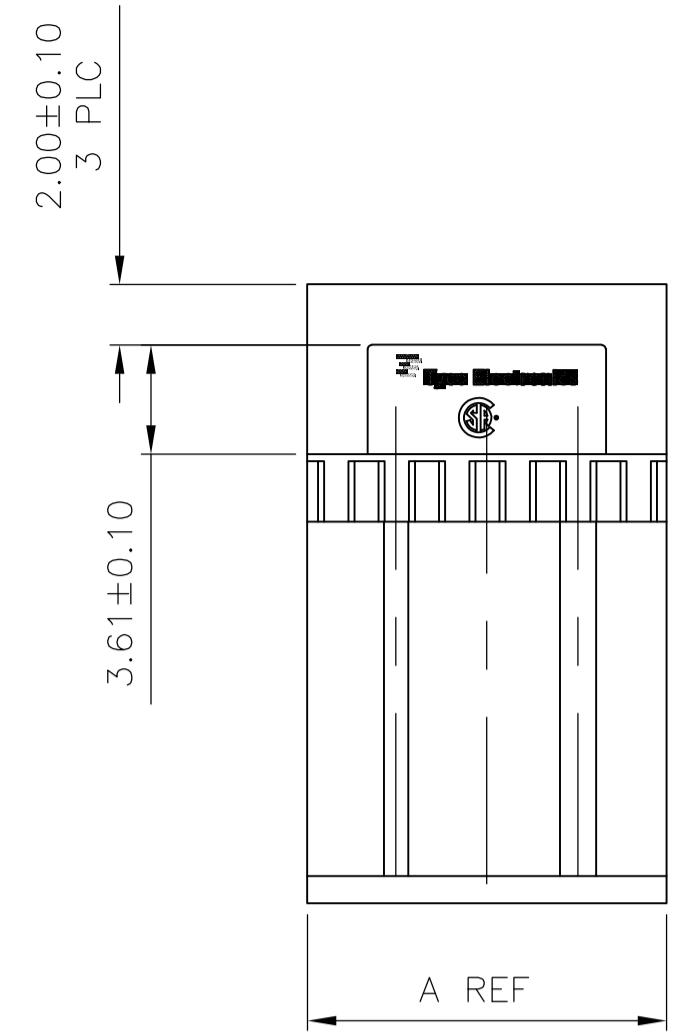

- △ HOUSING MATERIAL: LIQUID CRYSTAL POLYMER.
- △ CONTACT MATERIAL: PHOSPHOR-BRONZE.
- △ CONTACT FINISH:(D)  
 UNDERPLATE (ENTIRE CONTACT):  
 0.00127 MIN NICKEL PER SAE-AMS-QQ-N-290  
 ON MATING SURFACES:  
 FLASH GOLD PER ASTM B 488, OVER  
 0.00076 MIN PALLADIUM-NICKEL OVER UNDERPLATE, OR  
 0.00076 MIN GOLD PER ASTM B 488 OVER UNDERPLATE.  
 ON LEADS:  
 0.00381 MIN MATTE TIN PER ASTM B 545 OVER UNDERPLATE.  
 LUBRICATION (MIN MATING SURFACES):  
 SURFACE CONDITIONER AFTER PLATING.

RECOMMENDED CIRCUIT PATTERN  
 PER IPC-D300 TYPE II, CLASS C  
 (COMPONENT SIDE)

10	5	6	1	11.88	△	8	5536613-1
E	D	C	B	A	FINISH	NO OF POSN	PART NUMBER
THIS DRAWING IS A CONTROLLED DOCUMENT.				DIN D.R.BENDER 09/17/92		STE TE Connectivity	
DIMENSIONS: mm		TOLERANCES UNLESS OTHERWISE SPECIFIED:		CHK S.HEADER 01/25/93		NAME	
0 PLC ± - 1 PLC ± - 2 PLC ± 0.13 3 PLC ± - 4 PLC ± - ANGLES ± -		PRODUCT SPEC APPLICATION SPEC		Z-PACK 2mm FB, POWER MODULE, RCPT. ASSY. 4 ROW, 3.53 mm LEAD LENGTH		SIZE CAGE CODE DRAWING NO A1 00779 C=5536613	
MATERIAL		FINISH		WEIGHT		RESTRICTED TO	
△ △		△		A1 00779 C=5536613		CUSTOMER DRAWING	
				SCALE 4:1		SHEET 1 OF 1 REV A3	

## Looking for pricing, stock, or lifecycle information?

Click below to explore more details on WIN SOURCE:

 [View 5536613-1 on WIN SOURCE](#)

 [TE Connectivity](#) Information

## Optimize Your Supply Chain with WIN SOURCE Solutions

-  Global Sourcing Solution
-  Obsolete Management
-  Cost Control Management
-  Shortage Management
-  Alternative Solution
-  Excess Inventory Management