



THE DATASHEET OF
1053141212



NANO-FIT™

WIRE-TO BOARD CONNECTOR SYSTEM

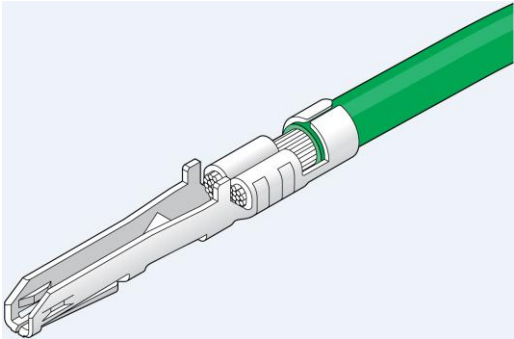
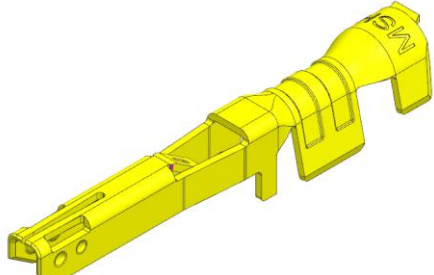
Female Crimp Terminal	Female Crimp Terminal
	
Series: 105300	Series: 105300

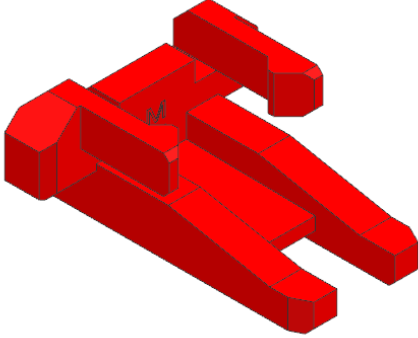
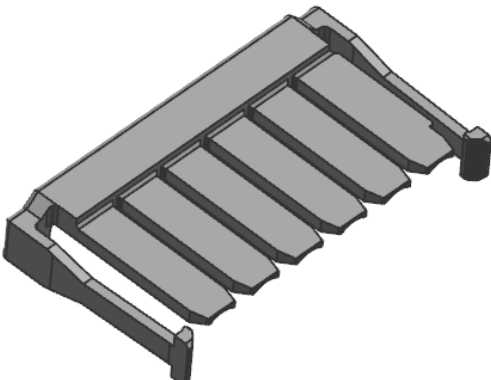
CPA	TPA
	
Series: 217140	Series: 105325



[Nano-Fit Web Page](#)

[TABLE OF CONTENTS](#)

REVISION:	ECR/ECN INFORMATION:		TITLE:	PRODUCT SPECIFICATION FOR NANO-FIT™ & WIRE TO BOARD POWER CONNECTOR SYSTEM	SHEET No.
J3	EC No:	792519			1 of 21
	DATE:	2024/09/24			
DOCUMENT NUMBER:		CREATED / REVISED BY:		CHECKED BY:	APPROVED BY:
PS-105300-100		Dixon Li		Nicolas Zhang	Nicolas Zhang

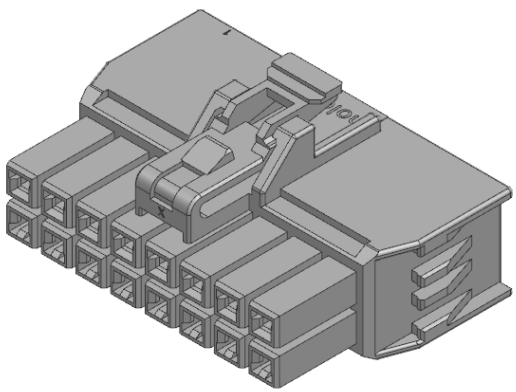
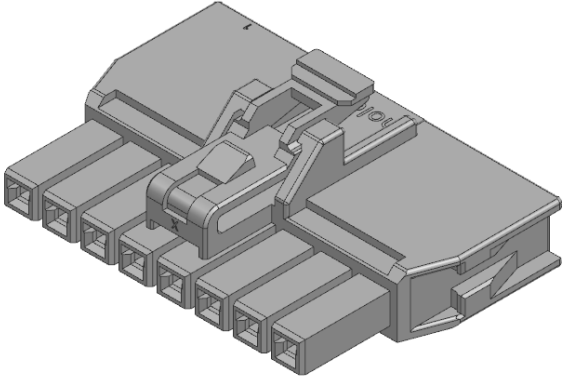
Receptacle Housing Dual Row (UL1569/1007)	Receptacle Housing Single Row (UL1569/1007)
	
Series: 226362	Series: 226354

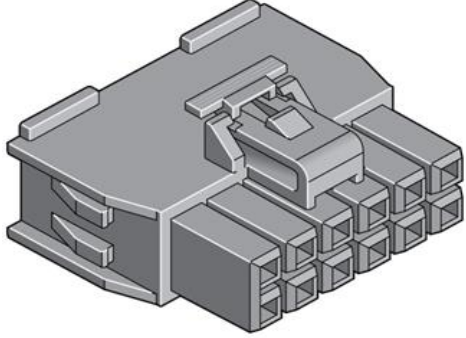
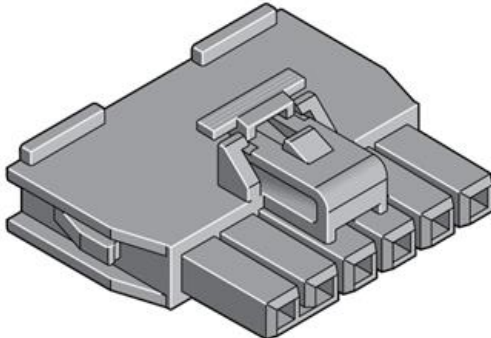
Receptacle Housing Dual Row	Receptacle Housing Single Row
	
Series: 105308	Series: 105307



[Nano-Fit Web Page](#)

[TABLE OF CONTENTS](#)

REVISION:	ECR/ECN INFORMATION:		TITLE:	PRODUCT SPECIFICATION FOR NANO-FIT™ & WIRE TO BOARD POWER CONNECTOR SYSTEM	SHEET No.
J3	EC No:	792519			2 of 21
	DATE:	2024/09/24			
DOCUMENT NUMBER:		CREATED / REVISED BY:		CHECKED BY:	APPROVED BY:
PS-105300-100		Dixon Li		Nicolas Zhang	Nicolas Zhang

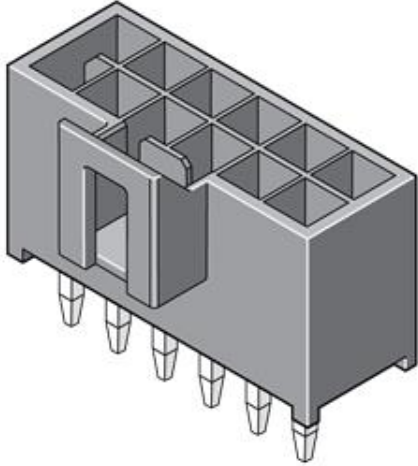
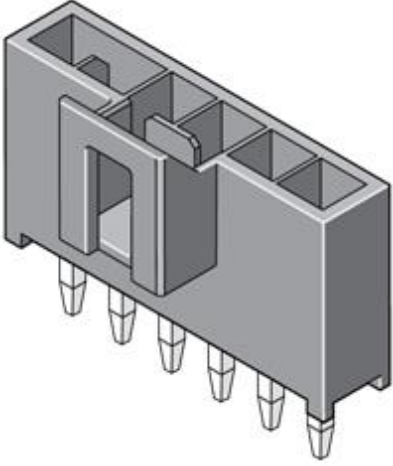
Vertical Header, Kinked Pins with Dual row	Vertical Header, Kinked Pins with Single row
	
Series: 105310	Series: 105309

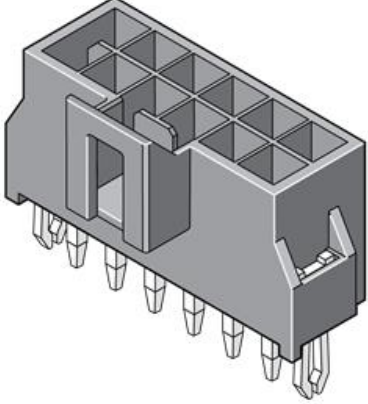
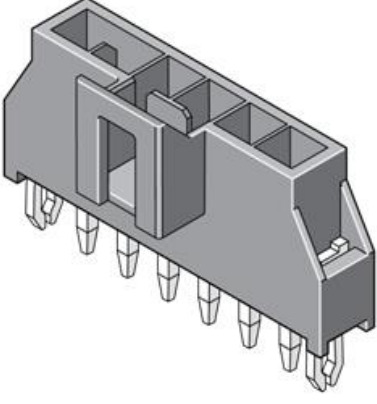
Vertical Header, Solder Clip with Dual Row	Vertical Header, Solder Clip with Single Row
	
Series: 105312	Series: 105311



[Nano-Fit Web Page](#)

[TABLE OF CONTENTS](#)

REVISION:	ECR/ECN INFORMATION:		TITLE:	PRODUCT SPECIFICATION FOR NANO-FIT™ & WIRE TO BOARD POWER CONNECTOR SYSTEM	SHEET No.
J3	EC No:	792519			3 of 21
	DATE:	2024/09/24			
DOCUMENT NUMBER:			CREATED / REVISED BY:	CHECKED BY:	APPROVED BY:
PS-105300-100			Dixon Li	Nicolas Zhang	Nicolas Zhang

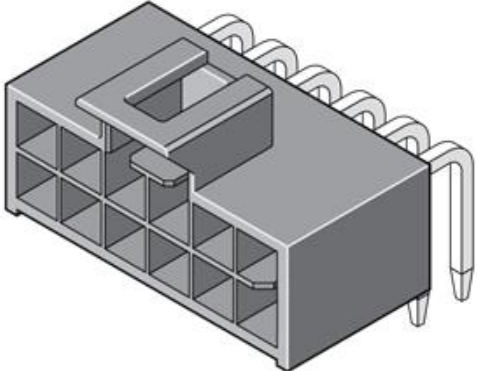
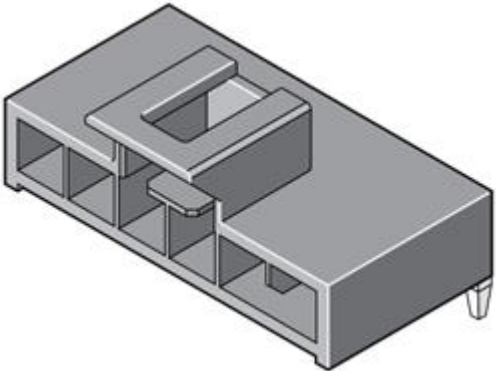
Right Angle Header Dual Row	Right Angle Header Single Row
	
Series: 105314	Series: 105313



[Nano-Fit Web Page](#)

[TABLE OF CONTENTS](#)

REVISION:	ECR/ECN INFORMATION:		TITLE:	PRODUCT SPECIFICATION FOR NANO-FIT™ & WIRE TO BOARD POWER CONNECTOR SYSTEM	SHEET No.
J3	EC No:	792519			4 of 21
	DATE:	2024/09/24			
DOCUMENT NUMBER:			CREATED / REVISED BY:	CHECKED BY:	APPROVED BY:
PS-105300-100			Dixon Li	Nicolas Zhang	Nicolas Zhang

Table of Contents

1.0	SCOPE	<u>5</u>
2.0	PRODUCT DESCRIPTION	<u>5</u>
2.1	Product Name and Series Numbers	<u>5</u>
2.2	Dimensions, Materials, Plating and Markings	<u>5</u>
2.3	Safety Agency Approvals	<u>5</u>
2.4	TPA Function	<u>6</u>
3.0	APPLICABLE DOCUMENTS AND SPECIFICATIONS	<u>6</u>
3.1	Molex Documents	<u>6</u>
3.2	Industry Documents	<u>7</u>
4.0	ELECTRICAL PERFORMANCE RATINGS	<u>7</u>
4.1	Voltage	<u>7</u>
4.2	Applicable Wires	<u>7</u>
4.3	Maximum Current Rating	<u>7</u>
4.4	Temperature	<u>8</u>
4.5	Durability	<u>8</u>
5.0	QUALIFICATION	<u>8</u>
6.0	PERFORMANCE	<u>9</u>
6.1	Electrical Performance	<u>9</u>
6.2	Mechanical Performance	<u>9</u>
6.3	Environmental Performance	<u>11</u>
7.0	TEST SEQUENCE GROUPS	<u>13</u>
8.0	SOLDER INFORMATION	<u>15</u>
8.1	Solder Process Temperature	<u>15</u>
8.2	Reflow Solder Profile	<u>15</u>
9.0	PACKAGING	<u>17</u>
10.0	CABLE TIE AND/OR WIRE TWIST LOCATION	<u>17</u>
11.0	POLARIZATION AND KEYING OPTIONS	<u>18</u>



[Nano-Fit Web Page](#)

[TABLE OF CONTENTS](#)

REVISION:	ECR/ECN INFORMATION:		TITLE:	PRODUCT SPECIFICATION FOR NANO-FIT™ & WIRE TO BOARD POWER CONNECTOR SYSTEM	SHEET No.
J3	EC No:	792519			5 of 21
	DATE:	2024/09/24			
DOCUMENT NUMBER:			CREATED / REVISED BY:	CHECKED BY:	APPROVED BY:
PS-105300-100			Dixon Li	Nicolas Zhang	Nicolas Zhang

1.0 SCOPE

This Product Specification covers the mechanical, electrical and environmental performances requirements and test methods of Nano-fit 2.50 mm pitch wire to board power connector series products, through hole type, terminated with 20, 22, 24 and 26 AWG stranded wire using crimp technology with tin or gold plating.

2.0 PRODUCT DESCRIPTION

2.1 product name and series number

Table 1 – WIRE-TO-BOARD	
Description	Series Number
Female Crimp Terminal	105300
Female Crimp Terminal (UL1569/1007)	226471
Receptacle Housing, Single Row	105307
Receptacle Housing, Dual Row	105308
Receptacle Housing, Single Row (UL1569/1007)	226354
Receptacle Housing, Dual Row (UL1569/1007)	226362
TPA Receptacle	105325
CPA Receptacle	217140
Vertical Header Single Row, Kinked Pins	105309
Vertical Header Dual Row, Kinked Pins	105310
Vertical Header Single Row, Solder Clips	105311
Vertical Header Dual Row, Solder Clips	105312
Right Angle Header Single Row, Solder Clips	105313
Right Angle Header Dual Row, Solder Clips	105314

2.2 Dimensions, materials, plating and markings

Dimensions & Plating: See individual sales drawings.

Material: RoHS compliant materials.

2.3 Safety agency approvals

- a) UL-1977 recognition file number: E29179.
- b) CSA approval file number: 1068385
- c) VDE Glow Wire approval file number: 569200-9020-0023/236653

WIRE TO BOARD:

CSA	Per UL
4 Amps @ 250V (20-26 AWG WIRE)	4 Amps at 250V (20-26 AWG WIRE)



[Nano-Fit Web Page](#)

[TABLE OF CONTENTS](#)

REVISION:	ECR/ECN INFORMATION:		TITLE:	SHEET No.
J3	EC No:	792519	PRODUCT SPECIFICATION FOR NANO-FIT™ & WIRE TO BOARD POWER CONNECTOR SYSTEM	6 of 21
	DATE:	2024/09/24		
	DOCUMENT NUMBER:			
PS-105300-100		Dixon Li	Nicolas Zhang	Nicolas Zhang

2.4 TPA function

- a) Make sure crimp terminal is properly seated.
- b) Increase crimp terminal retention force to receptacle, the spec is defined in section 6.2.2 and 6.2.3.

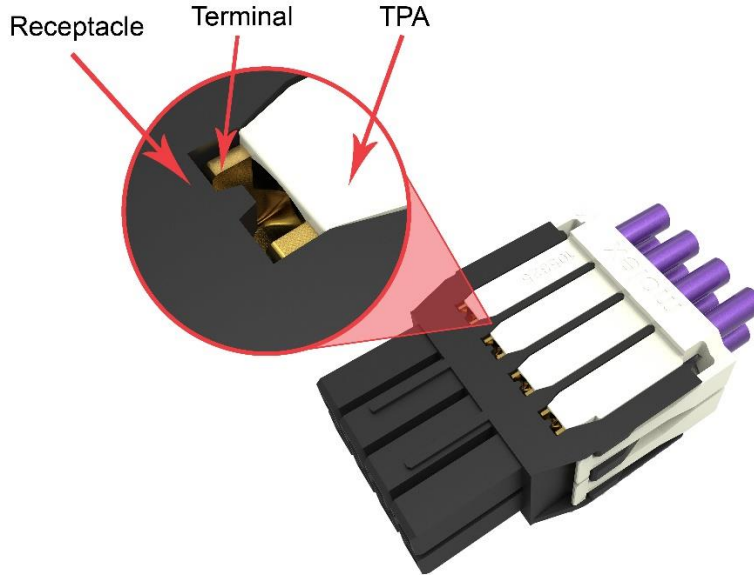

2.5 CPA function

- a) Increase the retention force of male and female connector.
- b) Preventing the latch structure from extrusion deformation during application.

3.0 APPLICABLE DOCUMENTS AND SPECIFICATIONS

3.1 Molex documents

See series specific sales drawings and the other sections of this specifications for the necessary referenced documents and specifications.

- [Nano-Fit Test summary 1053001000-TS-000](#)
- [Molex Quality Crimping Handbook Order No. 63800-0029](#)
- [Molex Solderability Specification SMES-152](#)
- [Molex Heat Resistance Specification AS-40000-5013](#)
- [Molex Moisture Technical Advisory AS-45499-001](#)
- [Molex Package Handling Specification 454990100-PK](#)
- ATS – Application Tooling Specification*



[Nano-Fit Web Page](#)

[TABLE OF CONTENTS](#)

REVISION:	ECR/ECN INFORMATION:		TITLE:	PRODUCT SPECIFICATION FOR NANO-FIT™ & WIRE TO BOARD POWER CONNECTOR SYSTEM	SHEET No.
J3	EC No:	792519			7 of 21
	DATE:	2024/09/24			
DOCUMENT NUMBER:			CREATED / REVISED BY:	CHECKED BY:	APPROVED BY:
PS-105300-100			Dixon Li	Nicolas Zhang	Nicolas Zhang

*Application Tooling Specification for terminals is not provided in this document. ATS for terminals can be available from respective terminal part number page in Molex.com.

3.2 Industrial documents

EIA-364-1000.01
 UL-60950-1
 CAS STD: C22.2 No. 182.3-M1987.
 IEC 60695-2-11, IEC 60335-1.

4.0 ELECTRICAL PERFORMANCE RATINGS

4.1 VOLTAGE *

250 Volts AC(RMS)/DC.

* This connector voltage rating meets the connector level provided by the safety agency.

4.2 APPLICABLE WIRES

Maximum Insulation Diameter and Applicable Wire Gauges	Stranded copper 26 AWG: 1.27 mm MAXIMUM
	Stranded copper 24 AWG: 1.27 mm MAXIMUM
	Stranded copper 22 AWG: 1.57 mm MAXIMUM
	Stranded copper 20 AWG: 1.57 mm MAXIMUM

4.3 MAXIMUM CURRENT RATING

Current rating is application dependent and may be affected by the wire rating as listed in UL-60950-1, table 3B. Each application should be evaluated by the end user for compliance to specific safety agency requirements. The ratings listed in the chart below are per Molex test method based on a 30° C maximum temperature rise over ambient temperature and are provided as a guideline. Appropriate de-rating is required based on circuit size, ambient temperature, copper trace size on the PCB, gross heating from adjacent modules/components and other factors that influence connector performance. Wire size & stranding, tin coated or bare copper, wire length & crimp quality are other factors that influence current rating.

Wire to Board Current Rating (Amp Max.)

(As tested with **tinned** copper wire and **gold 15u"** plated terminals)

Connector fully loaded with all circuits powered

AWG Wire Size	Ckt Size(Single row)							Ckt Size(Dual row)						
	2	3	4	5	6	7	8	4	6	8	10	12	14	16
20	8.00	*7.75	*7.50	*7.25	*7.00	*6.75	6.50	7.50	*7.17	*6.83	*6.50	*6.17	*5.83	5.50
22	6.50	*6.17	*5.83	*5.50	*5.17	*4.83	4.50	5.50	*5.25	*5.00	*4.75	*4.50	*4.25	4.00
24	6.00	*5.75	*5.50	*5.25	*5.00	*4.75	4.50	5.50	*5.17	*4.83	*4.50	*4.17	*3.83	3.50
26	5.00	*4.75	*4.50	*4.25	*4.00	*3.75	3.50	4.00	*3.83	*3.67	*3.50	*3.33	*3.17	3.00



[Nano-Fit Web Page](#)

[TABLE OF CONTENTS](#)

REVISION:	ECR/ECN INFORMATION:		TITLE:	PRODUCT SPECIFICATION FOR NANO-FIT™ & WIRE TO BOARD POWER CONNECTOR SYSTEM	SHEET No.
J3	EC No:	792519			8 of 21
	DATE:	2024/09/24			
DOCUMENT NUMBER:			CREATED / REVISED BY:	CHECKED BY:	APPROVED BY:
PS-105300-100			Dixon Li	Nicolas Zhang	Nicolas Zhang

- 1) Values are for REFERENCE ONLY.
- 2) Current deratings are based on not exceeding 30° C Temperature Rise.
- 3) PCB trace design can greatly affect temperature rise results in Wire-to-Board applications.
- 4) Data is for all circuits powered.
- 5) * indicates interpolated information.



4.4 TEMPERATURE

Operating temperature (including T-rise from applied current) is rated -40°C to 125°C *.
 Field temperatures and field life: Tested per EIA-364-1000.01 to meet field temperature of 65°C for 10 years life per table-8.
 *The rated temperature of wire needs to be considered for the operating temperature application. for example, the rated temperature of UL 1015 wire is 105°C and can't be used at an operating temperature of 125°C.

4.5 DURABILITY

Tin plated: 25 cycles*
 Gold plated: 50 cycles*

* When tested in accordance with EIA-364-1000.01 test method (see Sec. 7.0 of this specification).
 Durability per EIA-364-09



[Nano-Fit Web Page](#)

[TABLE OF CONTENTS](#)

REVISION:	ECR/ECN INFORMATION:		TITLE:	PRODUCT SPECIFICATION FOR NANO-FIT™ & WIRE TO BOARD POWER CONNECTOR SYSTEM	SHEET No.
J3	EC No:	792519			9 of 21
	DATE:	2024/09/24			
DOCUMENT NUMBER:			CREATED / REVISED BY:	CHECKED BY:	APPROVED BY:
PS-105300-100			Dixon Li	Nicolas Zhang	Nicolas Zhang

5.0 QUALIFICATION.

Laboratory conditions and sample selection are in accordance with EIA-364-1000.01.

6.0 PERFORMANCE.

6.1 ELECTRICAL PERFORMANCE.

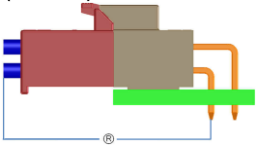
	DESCRIPTION	TEST CONDITION	REQUIREMENT
6.1.1	Contact Resistance (LLCR) 	EIA 364-23 Subject mated contacts assembled in housing to 20 mV maximum open circuit at 100 mA maximum. Wire resistance shall be removed from the measured value. * Never cross mate gold plated terminals to tin plated terminals.	10 milliohms Max(initial)
6.1.2	Insulation Resistance	EIA 364-21 After 500 VDC for 1 minute, measure the insulation resistance between the adjacent contacts of mated and unmated connector assemblies.	1000 Mega ohms MINIMUM
6.1.3	Glow Wire Test	IEC 60695-2-12 & IEC 60695-2-13 Test at temperature of 750°C & 850°C	Flames or glowing of the test specimen extinguish within 30 s after removal of the glow-wire, and there is no ignition of the wrapping tissue placed underneath the test specimen
6.1.4	Dielectric Withstanding Voltage	EIA 364-20 Method B Apply 1500 & 1800V DC for 1minute between adjacent terminals.	No breakdown current leakage <5mA
6.1.5	Temperature Rise & Voltage drop(via current cycling)	EIA 364-70 Method B 96hr steady state, 240hr current cycling, 96hr steady state using 2ckt with 20awg at rated current	Temperature rise: 30°C Max.



[Nano-Fit Web Page](#)

[TABLE OF CONTENTS](#)

REVISION:	ECR/ECN INFORMATION:		TITLE:	PRODUCT SPECIFICATION FOR NANO-FIT™ & WIRE TO BOARD POWER CONNECTOR SYSTEM	SHEET No.
J3	EC No:	792519			10 of 21
	DATE:	2024/09/24			
DOCUMENT NUMBER:			CREATED / REVISED BY:	CHECKED BY:	APPROVED BY:
PS-105300-100			Dixon Li	Nicolas Zhang	Nicolas Zhang

6.2 MECHANICAL PERFORMANCE.

	DESCRIPTION	TEST CONDITION	REQUIREMENT
6.2.1	Visual and dimensional inspections	EIA-364-18 Visual, dimensional and functional per applicable quality inspection plan.	Meet product drawing requirements.
6.2.2	Crimp Terminal Retention Force to housing (Without TPA)	EIA-364-37 Axial pullout force on the terminal in the housing at a rate of 25+/-6 mm per minute.	20N Min.
6.2.3	Crimp Terminal Retention Force (With TPA)	EIA-364-37 Axial pullout force on the terminal in the housing at a rate of 25+/-6 mm per minute. (only populate 1 terminal per housing)	40N Min
6.2.4	Crimp Terminal Insertion Force (into housing)	EIA-364-37 Apply an axial insertion force on the terminal at rate of 25+/-6 mm per minute	15.0N Max
6.2.5	Durability	EIA-364-09 Mate connectors at a Max rate of 10 cycles per minute prior to environmental tests. 25 cycles for tin, 50 cycles for gold.	10 milliohms Max change from initial. Visual : no damage.
6.2.6	Vibration (Random)	EIA-364-28 Mate connectors and vibrate per test condition VII-D, 15 minutes per axis for tin, 1.5hrs for gold.	10 milliohms Max change from initial. discontinuity <1 microsecond
6.2.7	USCAR Vibration	USCAR-2 Rev 6, Vibration Test sequence M per section 5.9.6, Classification: V1, S1, T3. Note: Voltage drop test with terminals in the housings, do not remove	10 milliohms Max change from initial. discontinuity <1 microsecond
6.2.8	Header Engagement Force to PCB(normal size)	Apply a PCB perpendicular force on connector, mounting it on PCB. Nominal PCB hole diameter and location	Vertical : 20 N Max Right angle : 10 N Max



[Nano-Fit Web Page](#)

[TABLE OF CONTENTS](#)

REVISION:	ECR/ECN INFORMATION:		TITLE:	PRODUCT SPECIFICATION FOR NANO-FIT™ & WIRE TO BOARD POWER CONNECTOR SYSTEM	SHEET No.
J3	EC No:	792519			11 of 21
	DATE:	2024/09/24			
DOCUMENT NUMBER:			CREATED / REVISED BY:	CHECKED BY:	APPROVED BY:
PS-105300-100			Dixon Li	Nicolas Zhang	Nicolas Zhang

6.2.9	Header retention force to PCB(normal size, do not solder)	Pull header off PCB at speed of 25+/-6mm per minute	Solder clip : 10N Min Kinked : 2N Min
6.2.10	Header solder clip Retention Force (in housing)	Apply a PCB perpendicular force on connector with only two clips, until push out the clip.	50 N Min
6.2.11	Header Terminal Retention Force to housing	EIA-364-29 Push from mating side and Push from PCB side per 25+/-6 mm per minute.	Push from mating side 25N Min Push from PCB side 9.8 N Min
6.2.12	Wire retention force (wire to crimp terminal, by application tooling)	EIA-364-37 Apply an axial pullout force on the wire at a rate of 25+/-6 mm per minute	20 AWG, 58.0N Min 22 AWG, 36.0N Min 24 AWG, 22.3N Min 26 AWG, 13.4N min
6.2.13	Connector Mating/Unmating force (receptacle to header W/O latch)	EIA 364-13 Insert and withdraw at a rate of 25+/-6mm per minute.	Mating spec : 3.5N Max per pin for Tin, 1.75N Max per pin for gold ; Unmating spec : 1.0N Min per pin for Tin, 0.5N Min per pin for gold.
6.2.14	latch mating-unmating force(header to receptacle, W/O TML)	EIA 364-13 Insert/withdraw receptacle at a rate of 25+/-6mm per minute.	Mating force : 10 N Max. Unmating force : 35N Min(with or w/o CPA).
6.2.15	Latch unmating force after durability (header to receptacle, W/O TML)	EIA 364-13 Insert/withdraw receptacle at a rate of 25+/-6mm per minute.	200 cycles, without damage and meet the spec : unmating force : 35 N Min after 20 cycles, 30 N Min after 200 cycles
6.2.16	Reseating	Unmate/Mate connectors by hand three cycles	Maximum Change from Initial: 10 mΩ

6.3 ENVIRONMENTAL PERFORMANCE.

	DESCRIPTION	TEST CONDITION	REQUIREMENT
6.3.1	Durability with Environment (precondition)	Mate connectors 3 cycles for tin plated and 5 cycles for gold plated connectors at a maximum rate of 10 cycles per minute. Per EIA-364-09, test method per Sec. 7	Visual: No damage 10 milliohms Max change from initial.



[Nano-Fit Web Page](#)

[TABLE OF CONTENTS](#)

REVISION:	ECR/ECN INFORMATION:		TITLE:	PRODUCT SPECIFICATION FOR NANO-FIT™ & WIRE TO BOARD POWER CONNECTOR SYSTEM	SHEET No.
J3	EC No:	792519			12 of 21
	DATE:	2024/09/24			
DOCUMENT NUMBER:		CREATED / REVISED BY:	CHECKED BY:	APPROVED BY:	
PS-105300-100		Dixon Li	Nicolas Zhang	Nicolas Zhang	

6.3.2	Cyclic Temperature and Humidity	EIA-364-31 Mate connectors: expose to 24 cycles from 25 °C/80% RH to 65°C/50% RH. Ramp time: 0.5hr; dwell time: 1.0hr.	10 milliohms Max change from initial.
6.3.4	Thermal Shock	EIA-364-32 Test Condition I. Subject mated connectors to 5 cycles between -55°C and +85°C.	10 milliohms Max change from initial. Visual: no damage;
6.3.5	Thermal Aging (temperature life)	EIA-364-17, Method A, mate connectors, expose to 500 hours at 125°C.	10 milliohms Max change from initial.
6.3.6	Thermal Aging (Precondition)	EIA-364-17, Method A, mate connectors, expose to 200 hours at 125°C.	10 milliohms Max change from initial.
6.3.7	Thermal Cycling (tin plated only)	Cycle mated connector between 15°C+/-3°C and 85°C+/-3°C as measured on the part. Ramps should be minimum of 2°C per minute, and dwell times should insure contacts reach the temperature extremes (minimum of 5 minutes). Humidity is not controlled. Perform 500 cycles.	10 milliohms Max change from initial.
6.3.8	Solderability dip test	Dip solder tails into the molten solder (held at 245 +5°C/-5°C) up to 0.5mm from the tip of tail for 5 ± 0.5sec. (EIA-364-52, SMES-152)	Solder coverage: 95% Min.
6.3.9	Reflow Solder Resistance	Convection reflow solder process 260°C Max per ES-40000-5013	Visual: No damage.
6.3.10	Wave Solder Resistance	Dip connector terminals tail in solder. Solder Duration: 5+/-0.5 seconds; Solder temperature: 260+/-5°C	Visual: No damage.
6.3.11	Mixed Flowing Gas (gold 0.76um + lube part only)	EIA-364-65 with Class IIA Gas concentrations (gold plated only) 240 hours unmated, 96 hours mated.	10 milliohms Max change from initial. Visual: no damage;
6.3.12	Thermal disturbance (gold plated only)	EIA-364-1000.01 test group 4, cycle mated connector between 15°C and 85°C for 10 cycles at a rate of 2°C/min. humidity is not controlled.	10 milliohms Max change from initial. Visual: no damage;



[Nano-Fit Web Page](#)

[TABLE OF CONTENTS](#)

REVISION:	ECR/ECN INFORMATION:		TITLE:	PRODUCT SPECIFICATION FOR NANO-FIT™ & WIRE TO BOARD POWER CONNECTOR SYSTEM	SHEET No.
J3	EC No:	792519			13 of 21
	DATE:	2024/09/24			
DOCUMENT NUMBER:			CREATED / REVISED BY:	CHECKED BY:	APPROVED BY:
PS-105300-100			Dixon Li	Nicolas Zhang	Nicolas Zhang

7.0 TEST SEQUENCE GROUPS (reliability test sequences per 364-1000.01)

No.	Group I Temperature Life 160 contacts tin 160 contacts gold	Group II Thermal Shock 160 contacts tin 160 contacts gold	Group III Vibration 160 contacts tin 160 contacts gold	Group V Thermal Cycling 160 contacts tin	Group VI(A) Durability 160 contacts tin 160 contacts gold	Group VI(B) Durability 160 contacts tin 160 contacts gold
01	Initial Contact Resistance(6.1.1)	Initial Contact Resistance(6.1.1)	Initial Contact Resistance(6.1.1)	Initial Contact Resistance(6.1.1)	Dielectric Withstanding Voltage(6.1.4)	Initial Contact Resistance(6.1.1)
02	Durability(6.3.1)	Durability(6.3.1)	Durability(6.3.1)	Durability(6.3.1)	Durability(6.2.5)	Durability(6.2.5)
03	Contact resistance	Contact resistance	Contact resistance	Contact resistance	Insulation Resistance(6.1.2)	Contact resistance
04	Thermal Aging(6.3.5)	Thermal shock(6.3.4)	Thermal Aging(6.3.6)	Thermal Aging(6.3.6)	Dielectric Withstanding Voltage(6.1.4)	
05	Contact resistance	Contact resistance	Contact resistance	Contact resistance		
06	Reseating(6.2.16)	Cyclic Temperature and Humidity(6.3.2)	Vibration(6.2.6)	Thermal Cycling(6.3.7)		
07	Contact resistance	Contact resistance	Contact resistance	Contact resistance		
08		Reseating(6.2.16)		Reseating(6.2.16)		
09		Contact resistance		Contact resistance		



[Nano-Fit Web Page](#)

[TABLE OF CONTENTS](#)

REVISION:	ECR/ECN INFORMATION:		TITLE:	PRODUCT SPECIFICATION FOR NANO-FIT™ & WIRE TO BOARD POWER CONNECTOR SYSTEM	SHEET No.
J3	EC No:	792519			14 of 21
	DATE:	2024/09/24			
DOCUMENT NUMBER:		CREATED / REVISED BY:		CHECKED BY:	APPROVED BY:
PS-105300-100		Dixon Li		Nicolas Zhang	Nicolas Zhang

7.1 Individual Tests:

Connector Mating/Unmating force (6.2.13)

Thumb Latch durability (6.2.15)

Temperature Rise (6.1.5)

USCAR Vibration (6.2.7)

Wire retention force (6.2.12)

Header retention force (6.2.9)

Header pin Retention force (6.2.11)

Glow wire test (6.1.3)

Crimped Terminal Retention force (6.2.2)

Crimped Terminal Retention force (with TPA) (6.2.3)

Wave/Reflow Solder Resistance (6.3.9/ 6.3.10)

Crimp terminal insertion force (6.2.4)

Solderability (6.3.8)

Header solder clip retention force(6.2.10)

Header Engagement forces on PCB (6.2.8)

Thumb Latch lock/unlock force(6.2.14)

USCAR Vibration (6.2.7)

Visual Inspection
USCAR-2 Rev6: 5.1.8

Initial Contact Resistance
USCAR-2 Rev6: 5.3.1

Connector Cycling
USCAR-2 Rev6: 5.1.7
10 cycles

Contact Resistance
USCAR-2 Rev6: 5.3.1

Vibration
USCAR-2 Rev6: 5.4.6
Continuity Monitoring
USCAR-2 Rev6: 5.1.9

Mechanical Shock
USCAR-2 Rev6: 5.4.6
Continuity Monitoring
USCAR-2 Rev6: 5.1.9

Contact Resistance
USCAR-2 Rev6: 5.3.1

Visual Inspection
USCAR-2 Rev6: 5.1.8

[Molex Solderability Specification SMES-152 \(Click Here\)](#)



[Nano-Fit Web Page](#)

[TABLE OF CONTENTS](#)

REVISION:	ECR/ECN INFORMATION:		TITLE:	PRODUCT SPECIFICATION FOR NANO-FIT™ & WIRE TO BOARD POWER CONNECTOR SYSTEM	SHEET No.
J3	EC No:	792519			15 of 21
	DATE:	2024/09/24			
DOCUMENT NUMBER:			CREATED / REVISED BY:	CHECKED BY:	APPROVED BY:
PS-105300-100			Dixon Li	Nicolas Zhang	Nicolas Zhang

8.0 SOLDER INFORMATION:

8.1 SOLDER PROCESS TEMPERATURES

Wave solder: 265°C Max
 Reflow solder: 260°C Max

[Molex Connector Heat Resistance Specification AS-40000-5013](#)
 (Click Here)

8.2 REFLOW SOLDERING PROFILE

(Below profile is per AS-40000-5013 and is provided as a guideline only. Please see notes for additional information)

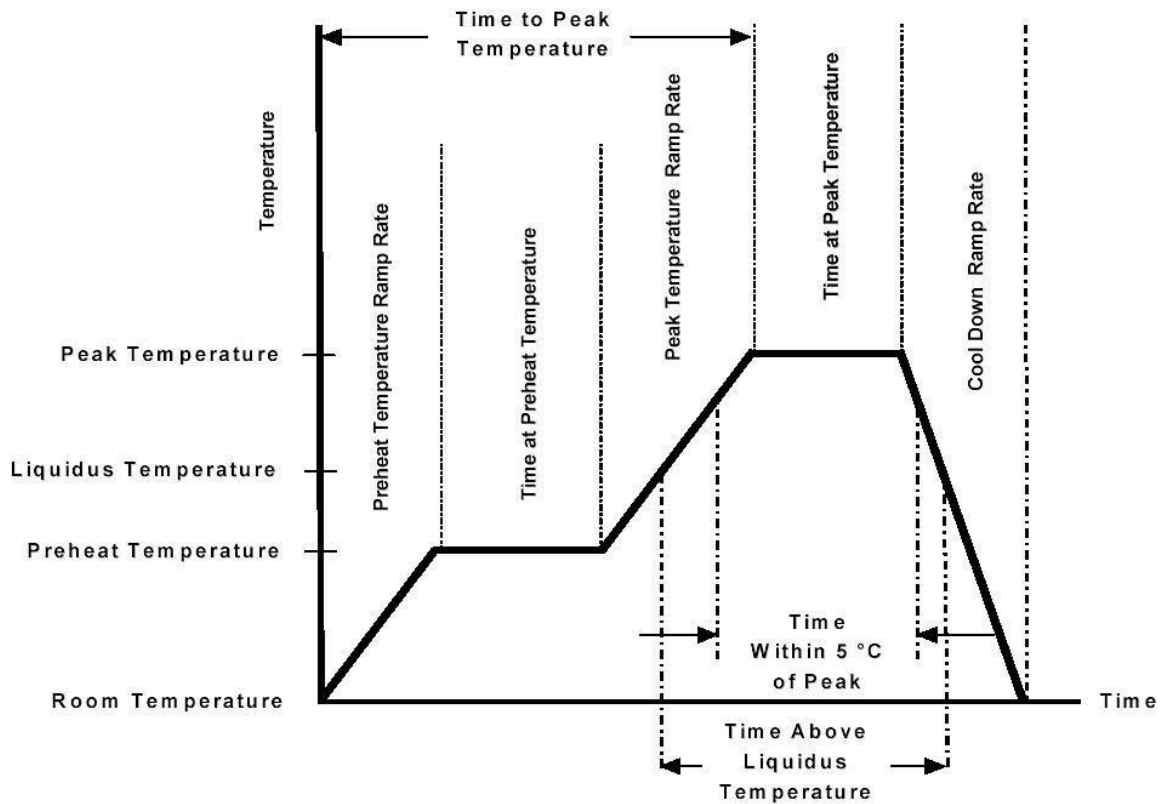

[Nano-Fit Web Page](#)

[TABLE OF CONTENTS](#)

REVISION:	ECR/ECN INFORMATION:		TITLE:	PRODUCT SPECIFICATION FOR NANO-FIT™ & WIRE TO BOARD POWER CONNECTOR SYSTEM	SHEET No.
J3	EC No:	792519			16 of 21
	DATE:	2024/09/24			
DOCUMENT NUMBER:			CREATED / REVISED BY:	CHECKED BY:	APPROVED BY:
PS-105300-100			Dixon Li	Nicolas Zhang	Nicolas Zhang

Description	Requirement
Average Ramp Rate	3°C/sec Max
Preheat Temperature	150°C Min to 200°C Max
Preheat Time	60 to 180 sec
Ramp to peak	3°C/sec Max
Time over Liquidus (217°C)	60 to 150 sec
Peak Temperature	260 +0/-5°C
Time within 5°C of Peak	20 to 40 sec
Ramp – Cool Down	6°C/sec Max
Time 25°C to Peak	8 min Max

Notes:

1. Temperature indicated refers to the PCB surface temperature at solder tail area.
2. Connector can withstand 2 reflow cycles. Customers must evaluate and determine suitability according to their reflow process, and follow the reflow soldering profile details provided in this document.
3. Actual reflow profile also depends on equipment, solder paste, PCB thickness, and other components on the board. Please consult your solder paste & reflow equipment manufacturer for their recommendations to adopt a suitable process.



[Nano-Fit Web Page](#)

[TABLE OF CONTENTS](#)

REVISION:	ECR/ECN INFORMATION:		TITLE:	PRODUCT SPECIFICATION FOR NANO-FIT™ & WIRE TO BOARD POWER CONNECTOR SYSTEM	SHEET No.
J3	EC No:	792519			17 of 21
	DATE:	2024/09/24			
DOCUMENT NUMBER:			CREATED / REVISED BY:	CHECKED BY:	APPROVED BY:
PS-105300-100			Dixon Li	Nicolas Zhang	Nicolas Zhang

9.0 PACKAGING

Parts shall be packaged to protect against damage during normal handling, transit and storage. “For specific part packaging details, refer to the packaging specification called out on the applicable product sales drawing.”

10.0 CABLE TIE AND/OR WIRE TWIST LOCATION

Circuit Sizes	Dim T Min. (single row)	Dim T Min. (dual row)
2	.50" (12.7 mm)	
4-6	.75" (19.1 mm)	.75" (19.1 mm)
8	1.00" (25.4 mm)	1.00" (25.4 mm)
10-12		1.25" (31.75 mm)
14-16		1.25" (31.75 mm)

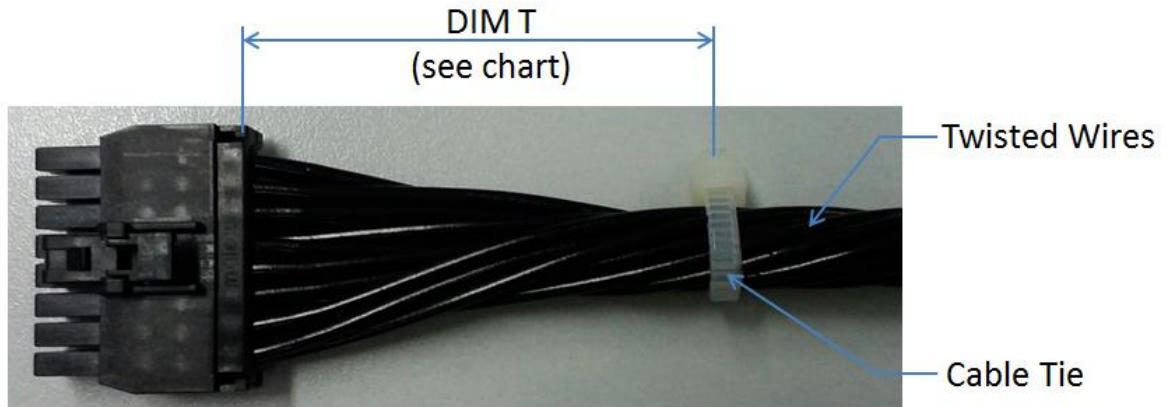

The “T” dimension defines a “free” length of wire, or a length of wire that is not subject to significant bias by external factors such as a wire tie, wire twisting, or other means of bending or deforming of the wires that repositions them from their natural relaxed state or location where they enter the housing. Wires are to be dressed in such a manner to allow the terminals to float freely in the pocket. This dimension is general recommendation and may need to be adjusted for different wire gauges and wire type and insulation thickness and insulation material.



[Nano-Fit Web Page](#)

[TABLE OF CONTENTS](#)

REVISION:	ECR/ECN INFORMATION:		TITLE:	PRODUCT SPECIFICATION FOR NANO-FIT™ & WIRE TO BOARD POWER CONNECTOR SYSTEM	SHEET No.
J3	EC No:	792519			18 of 21
	DATE:	2024/09/24			
DOCUMENT NUMBER:			CREATED / REVISED BY:	CHECKED BY:	APPROVED BY:
PS-105300-100			Dixon Li	Nicolas Zhang	Nicolas Zhang

11.0 POLARIZATION AND KEYING OPTIONS

11.1 Single Row Receptacle (Series: [105307](#))

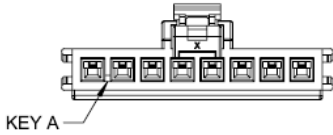

BLACK

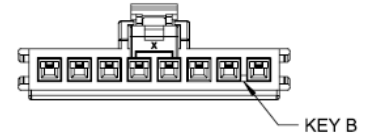

NATURAL

11.2 Dual Row Receptacle (Series: [105308](#))

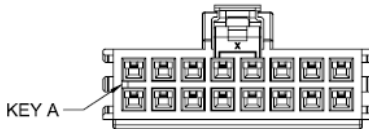

BLACK

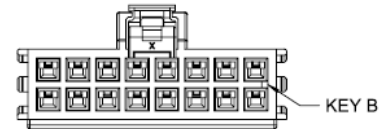

NATURAL

11.3 Vertical Header Single Row Kinked Pins (Series: [105309](#))

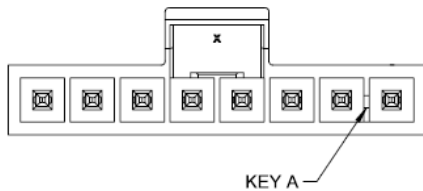

BLACK

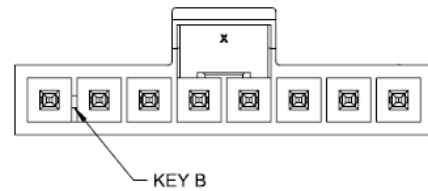

NATURAL



[Nano-Fit Web Page](#)

[TABLE OF CONTENTS](#)

REVISION:	ECR/ECN INFORMATION:		TITLE:	PRODUCT SPECIFICATION FOR NANO-FIT™ & WIRE TO BOARD POWER CONNECTOR SYSTEM	SHEET No.
J3	EC No:	792519			19 of 21
	DATE:	2024/09/24			
DOCUMENT NUMBER:			CREATED / REVISED BY:	CHECKED BY:	APPROVED BY:
PS-105300-100			Dixon Li	Nicolas Zhang	Nicolas Zhang

11.4 Vertical Header dual Row with kinked pins (Series: [105310](#))

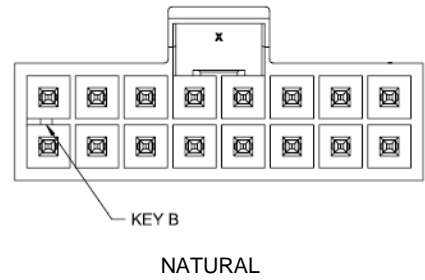
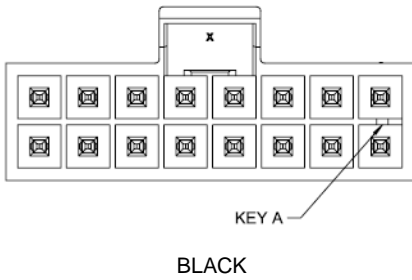

11.5 Vertical Header Single Row with Solder Clips (Series: [105311](#))

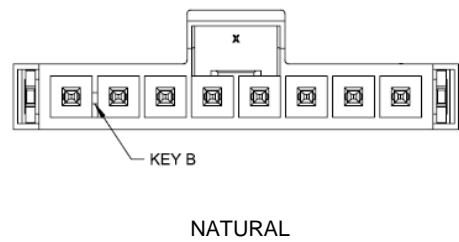
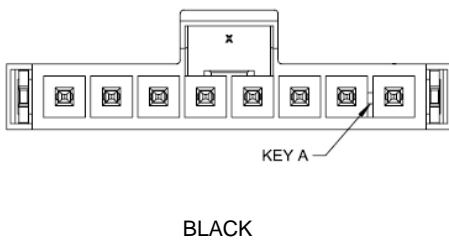

11.6 Vertical Header Dual Row Solder Clip (Series: [105312](#))

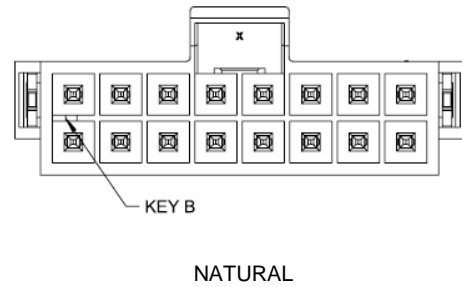
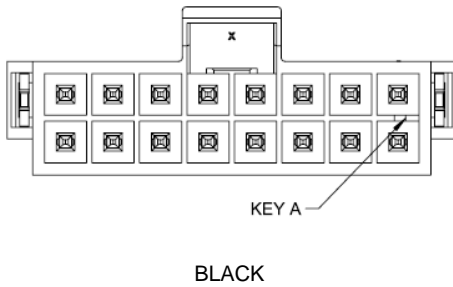

[Nano-Fit Web Page](#)

[TABLE OF CONTENTS](#)

REVISION:	ECR/ECN INFORMATION:		TITLE:	PRODUCT SPECIFICATION FOR NANO-FIT™ & WIRE TO BOARD POWER CONNECTOR SYSTEM	SHEET No.
J3	EC No:	792519			20 of 21
	DATE:	2024/09/24			
DOCUMENT NUMBER:			CREATED / REVISED BY:	CHECKED BY:	APPROVED BY:
PS-105300-100			Dixon Li	Nicolas Zhang	Nicolas Zhang

11.7 Right Angle Header Single Row (Series: [105313](#))

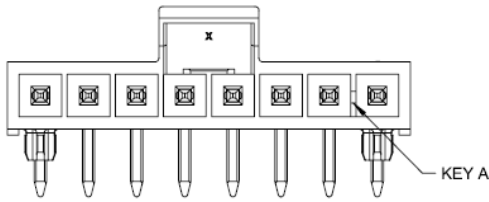

BLACK

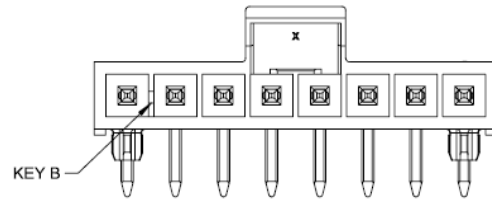

NATURAL

11.8 Right Angle Header Dual Row (Series: [105314](#))

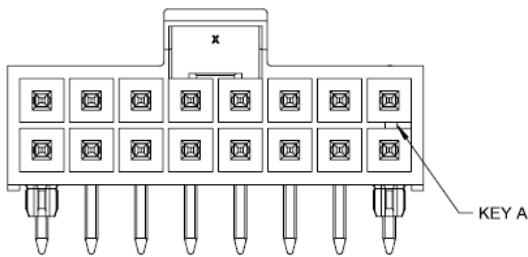

BLACK

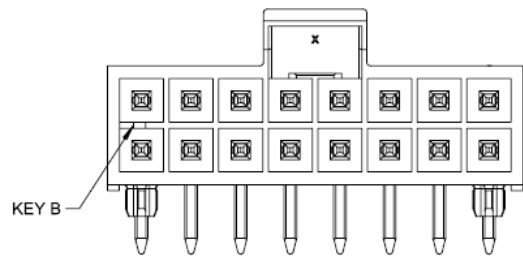

NATURAL



[Nano-Fit Web Page](#)

[TABLE OF CONTENTS](#)

REVISION:	ECR/ECN INFORMATION:		TITLE:	PRODUCT SPECIFICATION FOR NANO-FIT™ & WIRE TO BOARD POWER CONNECTOR SYSTEM	SHEET No.
J3	EC No:	792519			21 of 21
	DATE:	2024/09/24			
DOCUMENT NUMBER:			CREATED / REVISED BY:	CHECKED BY:	APPROVED BY:
PS-105300-100			Dixon Li	Nicolas Zhang	Nicolas Zhang

Looking for pricing, stock, or lifecycle information?

Click below to explore more details on WIN SOURCE:

 [View 1053141212 on WIN SOURCE](#)

 [MolexKits Information](#)

Optimize Your Supply Chain with WIN SOURCE Solutions

-  Global Sourcing Solution
-  Obsolete Management
-  Cost Control Management
-  Shortage Management
-  Alternative Solution
-  Excess Inventory Management