



Changes for the Better

for a greener tomorrow



POWER MODULES

Power
Modules

Innovative Power Devices for a Sustainable Future

Mitsubishi Electric power modules are at the forefront of the latest energy innovations that seek to solve global environmental issues while creating a more affluent and comfortable society for all. Some of these innovations are photovoltaic (PV) and wind power generation from renewable energy sources, smart grids realizing efficient supply of power, hybrid/electric vehicles (HVs/EVs) that take the next step in reducing carbon emissions and fuel consumption, and home appliances that achieve ground-breaking energy savings. Whether in appliances, railcars, EVs or industrial systems, our power modules are key elements in changing the way energy is used.

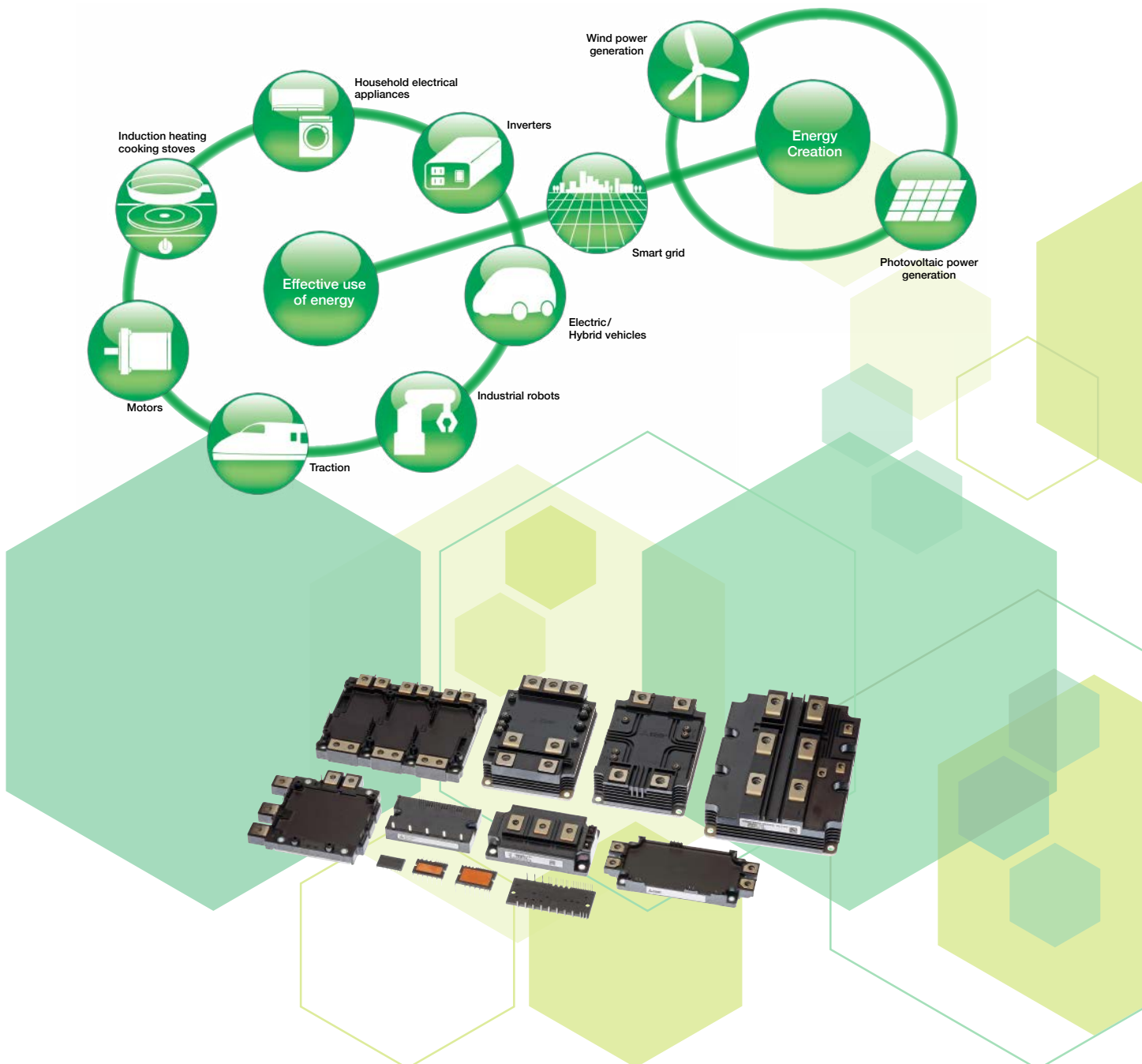



Focus Technology

7th-Generation 1,200V-Class IGBT Chip Technology Cutting-edge technology realizes energy-saving inverter devices

- Latest thin-wafer processing (n-drift layer) achieves thinner wafer than 6th-generation devices
- Performance improved by combining CSTBT™* and light punch-through (LPT) structures
- Inverter system power dissipation minimized by its superior performance (lower V_{CEsat} and E_{off})

*CSTBT™: Mitsubishi Electric's unique IGBT that makes use of carrier cumulative effect

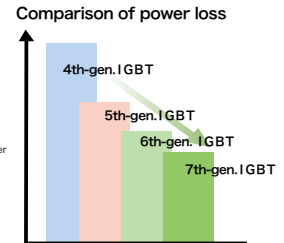
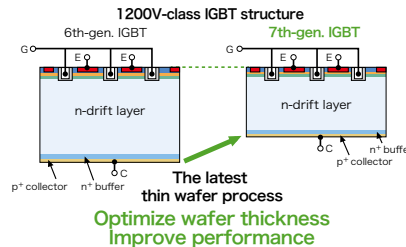

A small surface mount package IPM has been newly developed for fan and low-power motor drive applications

Key Features

- Optimal pin layout realizes easier PCB wiring design and enables smaller PCB size
- Newly integrated interlock function in addition to conventional protection features for robust operation
- Bootstrap diode is integrated for the P-side drive power supply like conventional DIIPM™ series, reducing the number of peripheral external parts



Modules realizing single-control power supply and photocoupler-less systems for household appliances and low-capacity inverters

Key Features

- Transfer-molded structure incorporating a high thermal conductivity insulation sheet provides heat
- High-voltage IC equipped with drive, protection and level-shift circuits for direct control via input signals from a CPU or microcomputer
- Compact board and highly reliable equipment realized through single power-supply and photocoupler-less systems
- Includes built-in bootstrap diode (BSD)



Modules with built-in control and protection circuits for AC servo robots and PV power generation

Key Features

- Built-in protection circuits for short-circuiting, power supply undervoltage and overheating
- Highly compatible package with simplified printed circuit board (PCB) design
- Special intelligent power modules (IPMs) for power conditioners in PV power generation systems



IGBT modules for general-purpose inverters used in various applications

Key Features

- Various low-inductance packages and power chips available
- Compatible with high-frequency, high-voltage (1,700V) applications
- Large-capacity modules available for renewable energy systems



High voltage, large capacity and high reliability are realized for traction and power transmission application

Key Features

- Two types of package are realized: "std type" with large output power and "dual type" for various inverter capacity by easy parallel connection
- The abundant field experience more than 20 years especially in the application of bullet train
- High reliability due to a long lifetime design and a robust design against severe environment

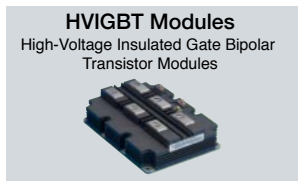

Modules realizing high performance and reliability for propulsion inverters in HVs/EVs

Key Features

- Built-in temperature analog output function realizing highly reliable drive train
- High-power/temperature cycle life ensures high reliability
- Compliant with the End-of-life Vehicles Directive, regulations relating to substances of environmental concern
- High traceability in managing materials/components throughout the entire production process for each product



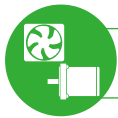

New Products

Data sheet here



Surface mount package IPM MISOP™

SP2SK, SP3SK

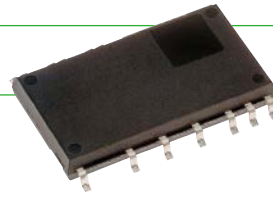

A small Surface mount package IPM has been newly developed for fan and low-power motor drive applications

<Main Features>

- Optimal pin layout realizes easier PCB wiring design and enables smaller PCB size
- Insulation distance between pins ensured, realizing easier board mounting without coating process
- Newly integrated interlock function in addition to conventional protection features for robust operation
- Installing RC-IGBT¹ simultaneously realizes compact package and low loss performance can go together
- Bootstrap diode is integrated for the P-side drive power supply like conventional DIPIM™ series, reducing the number of peripheral external parts

*1 Reverse-conducting IGBT

MISOP™

Type name	Rated current	Rated voltage	Chips	Protection	Shape
SP2SK**	2A	600V	RC-IGBT, HVIC, LVIC, BSD	UV, SC, OT, V _{OT} , IL	Surface mount package
SP3SK**	3A				

[Term] UV : Power supply Under Voltage protection
 SC : Short Circuit protection
 OT : Over Temperature protection
 V_{OT} : Analog Temperature Output
 IL : Inter Lock

** : Under development

Schematic drawing

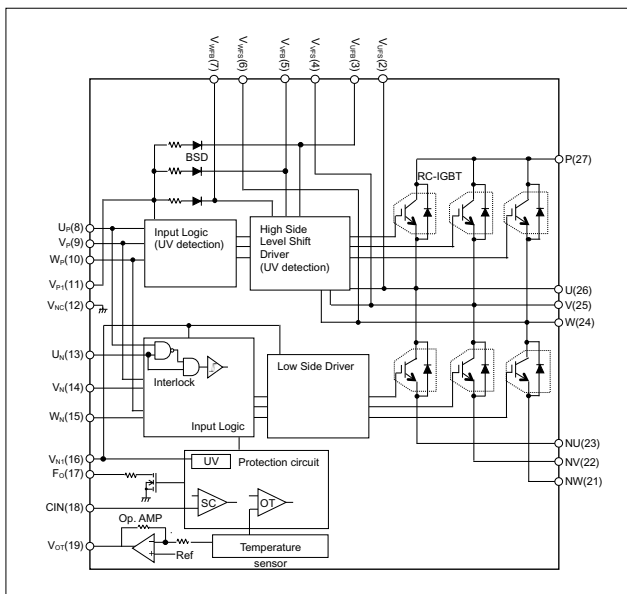

Outline Drawing

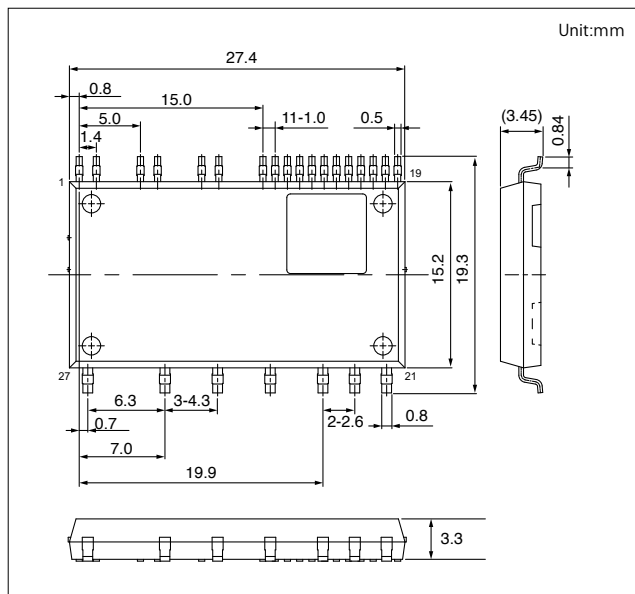



Featured Products

Smaller package size realized by integrating newly designed RC-IGBT
Recommended for low-cost inverter and fan controller applications

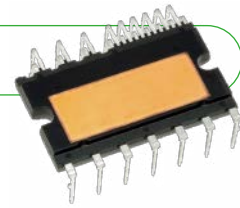

Data sheet here



SLIMDIP™

SLIMDIP-S, SLIMDIP-L

<Main Features>

- RC-IGBT^{*1} incorporated, reducing package size 30% compared to Super-mini DIIPM
- Maximum case temperature increased from 100°C to 115°C, increasing the operating temperature range and leading to easier system design
- Additional terminals for floating supply and built-in bootstrap diodes simplify PCB wiring pattern
- Both VOT^{*2} and OT^{*3} functions integrated for temperature protection

- *1 Reverse conducting IGBT
- *2 Analog Temperature Output
- *3 Over Temperature protection

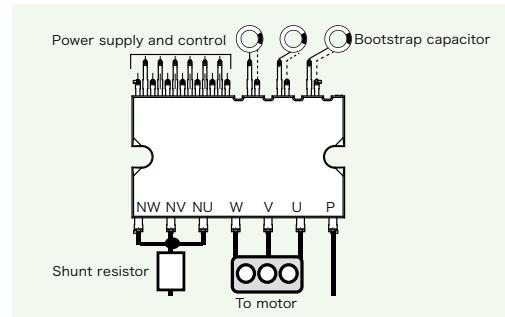

Featured Products

All-in-one intelligent power modules equipped with 3-phase converter and brake circuit in addition to inverter circuit

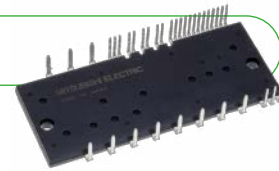

Data sheet here



DIIPM+™

PSS05MC1FT, PSS10MC1FT, PSS15MC1FT,
PSS25MC1FT, PSS35MC1FT, PSS50MC1F6

<Main Features>

- Encapsulated with transfer molded resin, integrates three-phase converter, inverter, brake and control IC
- Built-in converter and brake enable system size to be reduced and save design cost, contributing to total cost reduction
- Lower PCB inductance pattern reduces noise, thereby reducing design time and countermeasure parts required for noise reduction
- Built-in BSD^{*1} with 1,200V withstand voltage reduces number of external parts and improves reliability

- *1 Bootstrap diode
- *2 Without brake circuit types are also line-up

Internal circuit diagram

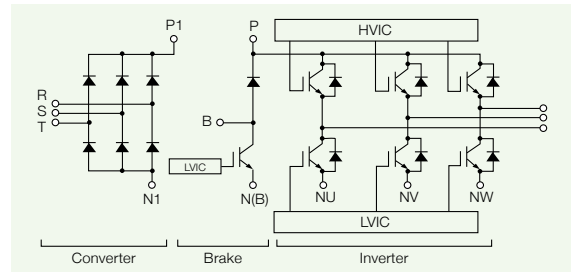

Customer Support

EVA series, evaluation boards for each DIIPM™
Various evaluation boards to easy support system design



Super mini DIIPM™
evaluation board
EVA11-SDIP

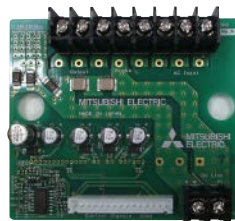

DIIPM+™ evaluation board
EVA14-DIP+



SLIMDIP™ evaluation board
EVA01-SLIM



SLIMDIP™ evaluation board
EVA15-SLIM



DIIPM+™
evaluation
board
EVA03-DIP+

* For further information, please contact sales office.

Line-up of DIIPM™

Series Matrix of 600V / 500V DIIPM™

V _{CEs} (V)		600V					500V
I _c (A)	Series	SLIMDIP	Super mini	Mini	Large	DIIPM+	Super mini
			Ver.6		Ver.4	CIB/CI	MOSFET
3	SLIMDIP-S						PSM03S93E5-A
5		PSS05S92F6-AG PSS05S92E6-AG	PSS05S51F6				PSM05S93E5-A
10	SLIMDIP-L						
15		PSS10S92F6-AG PSS10S92E6-AG	PSS10S51F6				
20							
30							
35							
50				PSS50S71F6	PS21A79	PSS50MC1F6 PSS50NC1F6 *5	
75					PS21A7A		
Chip	IGBT/MOSFET	RC-IGBT	CSTBT	CSTBT	CSTBT	CSTBT	MOSFET
Protective Function	UV	P-side/N-side	P-side/N-side	P-side/N-side	P-side/N-side	P-side/N-side/Brake part	P-side/N-side
	SC	N-side	N-side	N-side	N-side with sense	N-side	N-side
	OT	N-side	N-side*1	—	—	—	N-side
	V _{OT}	N-side	N-side*1	N-side	N-side	N-side	—
Specifications	Active input	High(3/5V)	High(3/5V)	High(3/5V)	High(3/5V)	High(5V)	High(3/5V)
	Emitter pin of N-side	Open	Open	Open	Open	Open	Open
	Fault output	N-side(UV,SC,OT)	N-side (UV,SC,OT)	N-side (UV,SC)	N-side (UV,SC)	N-side (UV,SC)	N-side (UV,SC,OT)
	Insulation voltage	2000Vrms*2	1500Vrms*2	2500Vrms	2500Vrms	2500Vrms	1500Vrms*2
	Insulation structure	Insulation sheet	Insulation sheet	Molding resin*4/Insulation sheet	Insulation sheet	Insulation sheet	Insulation sheet
	RoHS directive	Compliant	Compliant	Compliant *3	Compliant	Compliant	Compliant
	Pin type	Control side of Zigzag (Normal, Short)	Long	Control side of Zigzag, Short	—	—	Long

- [Notes] *1 : PSSxxS92E6 has OT function, PSSxxS92F6 has V_{OT} function
 *2 : AC60Hz, 1minute. Corresponds to isolation voltage 2500Vrms in the case the convex-shaped heat sink
 *3 : High melting point solder (Lead Over 85%) is used for chip soldering of PSSxxS51F6 only.
 *4 : Molding resin insulation for PSSxxS51F6/-C
 *5 : PSS50NC1F6 is not included brake.

- [Term] CSTBT™: Mitsubishi Electric's unique IGBT that makes use of the carrier cumulative effect
 RC-IGBT: Reverse conducting IGBT
 HVIC: High Voltage IC
 LVIC: Low Voltage IC
 BSD: Bootstrap Diode
 UV: Power supply Under Voltage protection
 OT: Over Temperature protection
 SC: Short Circuit protection
 V_{OT}: Analog Temperature Output
 RoHS: Restriction of the use of certain Hazardous Substances in electrical and electronic equipment
 CIB: Converter Inverter Brake,
 CI: Converter Inverter

Application circuit of super mini DIIPM™

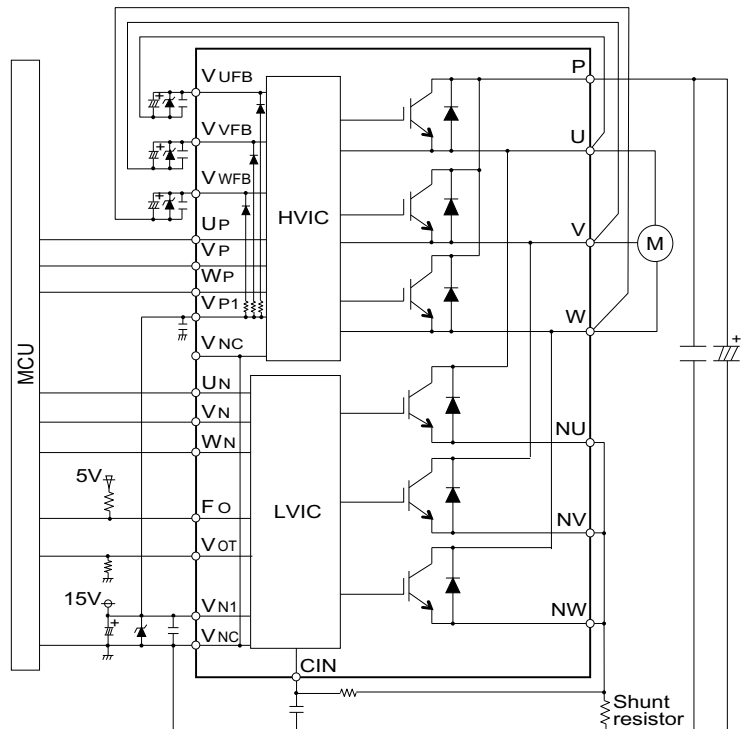

Series Matrix of 1200V DIIPM™

V _{ces} (V)		1200V			
I _c (A)	Series	Mini	Large		DIIPM+
			Ver.6	Ver.4	CIB/CI
5	PSS05S72FT	PSS05SA2FT	PS22A72		PSS05MC1FT PSS05NC1FT*1
10	PSS10S72FT	PSS10SA2FT	PS22A73		PSS10MC1FT PSS10NC1FT*1
15		PSS15SA2FT	PS22A74		PSS15MC1FT PSS15NC1FT*1
25		PSS25SA2FT	PS22A76		PSS25MC1FT PSS25NC1FT*1
35		PSS35SA2FT	PS22A78-E		PSS35MC1FT PSS35NC1FT*1
50		PSS50SA2FT	PS22A79		
75		PSS75SA2FT			
Chip	IGBT/MOSFET	CSTBT	CSTBT	CSTBT	CSTBT
Protective Function	UV	P-side/N-side	P-side/N-side	P-side/N-side	P-side/N-side/Brake
	SC	N-side	N-side	N-side	N-side
	OT	—	—	—	—
	V _{OT}	N-side	N-side	N-side	N-side
Specifications	Active input	High(5V)	High(5V)	High(5V)	High(5V)
	Emitter pin of N-side	Open	Open	Open	Open
	Fault output	N-side (UV,SC)	N-side (UV,SC)	N-side (UV,SC)	N-side (UV,SC)
	Insulation voltage	2500Vrms	2500Vrms	2500Vrms	2500Vrms
	Insulation structure	Insulation sheet	Insulation sheet	Insulation sheet	Insulation sheet
	RoHS directive	Compliant	Compliant	Compliant	Compliant
	Pin type	—	—	—	—

Not recommended : Please contact to the sales offices.

[Notes] *1: PSS**NC1FT is not included brake

[Term] BSD: Bootstrap Diode
 CSTBT™: Mitsubishi Electric's unique IGBT that makes use of the carrier cumulative effect
 HVIC: High Voltage IC
 LVIC: Low Voltage IC
 UV: Power supply Under Voltage protection
 OT: Over Temperature protection
 SC: Short Circuit protection
 V_{OT}: Analog Temperature Output
 RoHS: Restriction of hazardous substances in electrical and electronic equipment
 CIB: Converter Inverter Brake
 CI: Converter Inverter

Type Name Definition of DIIPM™

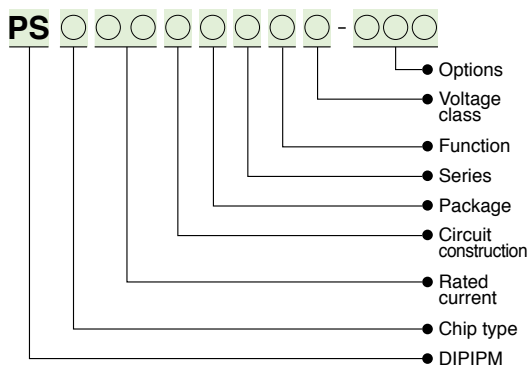

Outline Drawing of DIIPM™

Unit:mm

Super mini DIIPM Ver.6 MOSFET Super mini DIIPM Long

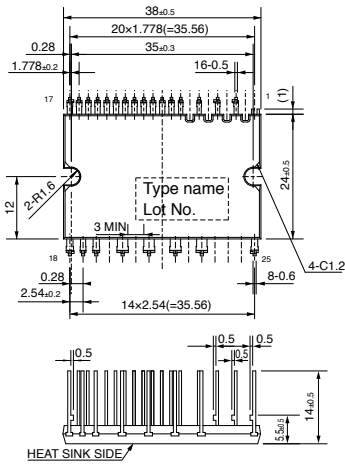

Mini DIIPM (PSSxxS71F6) 1200V Mini DIIPM

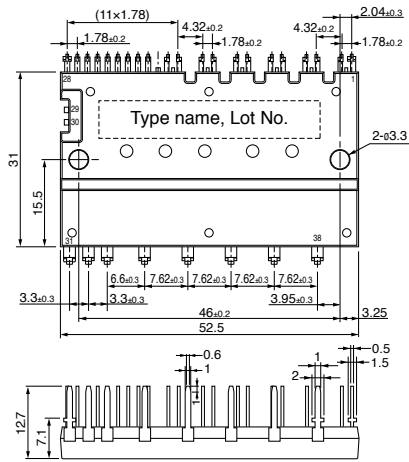

Mini DIIPM (PSSxxS51F6)

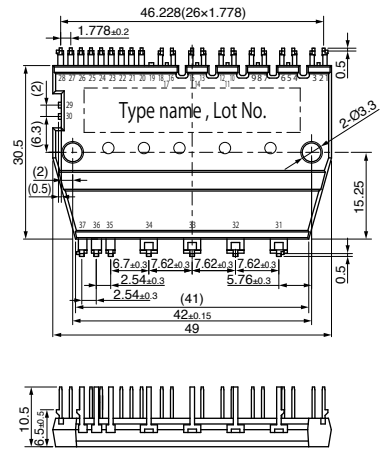

Mini DIIPM(PSSxxS51F6) Zigzag

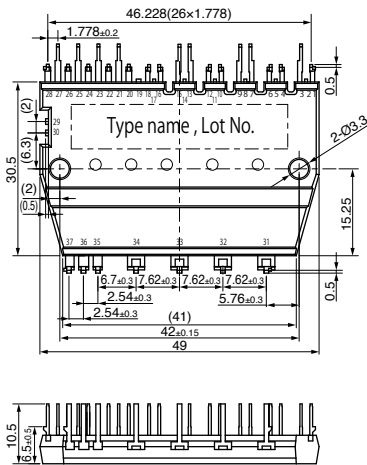

Large DIIPM

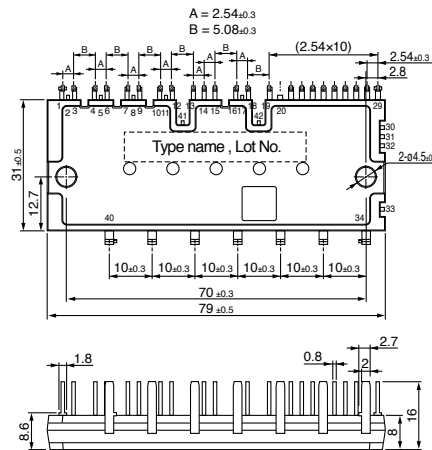

DIIPM+

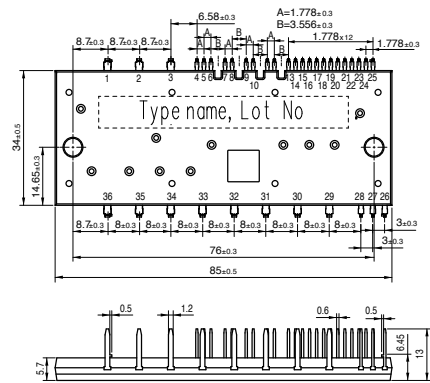

SLIMDIP Normal

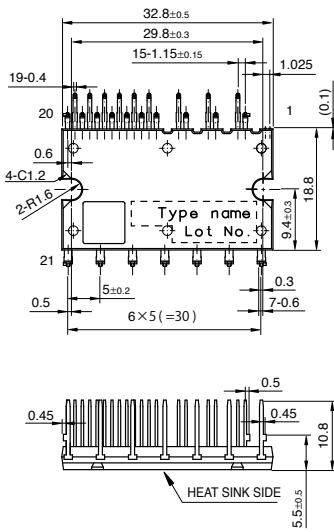

SLIMDIP Short

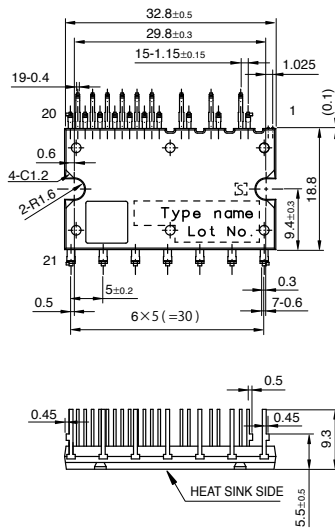



Featured Products

Loaded with built-in functions, contributing to inverters with enhanced energy savings

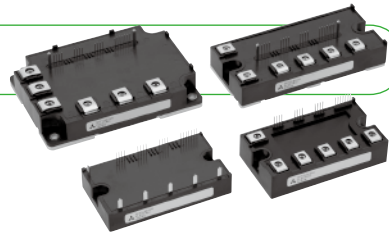

Data sheet here



G1 Series IPM with 7th-generation IGBT

<Main Features>

- Power loss has been reduced with the introduction of the 7th-generation IGBT produced using CSTBT™¹ and a diode incorporating a RFC² structure that contributes to reducing the power consumed in inverters
- The new resin-insulated metal baseplate, originally introduced in 7th-generation IGBT modules, eliminates the solder-attached section, increasing the thermal cycle lifetime and improving inverter reliability
- In addition to the built-in functions of the previous product,³ automatic switching speed control, and error detection function contribute to lowering inverter loss and shortening design time

*1 CSTBT™: Mitsubishi Electric's unique IGBT that utilizes the carrier cumulative effect

*2 RFC: Relaxed field cathode

*3 Conventional product: IPM L1-Series

Built-in functions: Supply Undervoltage lock protection (UV), Short-circuit protection (SC), Over-temperature protection (OT)

"A" package main pin shape and layout

For the "A" package 6-in-1 (CG1A) main pin shape, select either solder pin or screw type
For the pin layout, select either straight or L-shaped

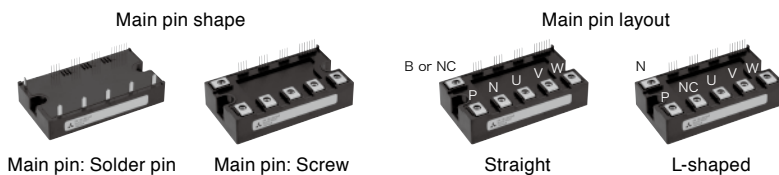

Lineup

V _{CE(S)} (V)	Package	Main pin shape	Main pin layout	I _c (A)										
				25	35	50	75	100	150	200	300	450		
650V	A package	Screw	Straight			PM50CG1A065 PM50RG1A065	PM75CG1A065 PM75RG1A065	PM100CG1A065						
			L-shaped			PM50CG1AL065	PM75CG1AL065	PM100CG1AL065						
		Solder pin	Straight			PM50CG1AP065 PM50RG1AP065	PM75CG1AP065 PM75RG1AP065	PM100CG1AP065						
			L-shaped			PM50CG1APL065	PM75CG1APL065	PM100CG1APL065						
	C package	Screw	L-shaped			PM50CG1B065 PM50RG1B065	PM75CG1B065 PM75RG1B065	PM100CG1B065 PM100RG1B065	PM150CG1B065 PM150RG1B065	PM200CG1B065 PM200RG1B065				
1200V	A package	Screw	Straight	PM25CG1A120 PM25RG1A120	PM35CG1A120 PM35RG1A120	PM50CG1A120								
			L-shaped	PM25CG1AL120	PM35CG1AL120	PM50CG1AL120								
		Solder pin	Straight	PM25CG1AP120 PM25RG1AP120	PM35CG1AP120 PM35RG1AP120	PM50CG1AP120								
			L-shaped	PM25CG1APL120	PM35CG1APL120	PM50CG1APL120								
	B package	Screw	L-shaped	PM25CG1B120 PM25RG1B120	PM35CG1B120 PM35RG1B120	PM50CG1B120 PM50RG1B120	PM75CG1B120 PM75RG1B120	PM100CG1B120 PM100RG1B120						
	C package	Screw	L-shaped					PM100CG1C120 PM100RG1C120	PM150CG1C120 PM150RG1C120	PM200CG1C120 PM200RG1C120				

Representative reference is "A" package with screw terminal and straight layout (CG1A).

Line-up of IPM

Matrix of IPM Modules 650V/600V (No.: Number of outline drawing, see page 11 to 12)

V _{CE} (V)	650V						600V											
	Series	G1 Series		L1 Series		S1 Series		V1 Series		Photovoltaic		L Series						
		Connection	No.	Connection	No.	Connection	No.	Connection	No.	Connection	No.	Connection	No.					
50	PM50CG1A065	C	12	PM50CL1A060	C	01	PM50CS1D060	C	05	PM50B4LA060	B4	01	PM50CLA060	C				
	PM50RG1A065	R	12							PM50B5LA060	B5	01						
	PM50CG1B065	C	10							PM50B6LA060	B6	01			PM50CLB060	C		
	PM50RG1B065	R	10							PM50B4LB060	B4	02			PM50RLA060	R		
	PM50CG1AL065	C	12							PM50B5LB060	B5	02			PM50RLB060	R		
	PM50CG1AP065	C	09							PM50B6LB060	B6	02						
	PM50CG1APL065	C	09							PM50B4L1C060	B4	03						
	PM50RG1AP065	R	09							PM50B5L1C060	B5	03						
										PM50B6L1C060	B6	03						
75	PM75CG1A065	C	12	PM75CL1A060	C	01	PM75CS1D060	C	05	PM75B4LA060	B4	01	PM75CLA060	C				
	PM75RG1A065	R	12							PM75B5LA060	B5	01						
	PM75CG1B065	C	10							PM75B6LA060	B6	01			PM75CLB060	C		
	PM75RG1B065	R	10							PM75B4LB060	B4	02			PM75RLA060	R		
	PM75CG1AL065	C	12							PM75B5LB060	B5	02			PM75RLB060	R		
	PM75CG1AP065	C	09							PM75B6LB060	B6	02						
	PM75CG1APL065	C	09							PM75B4L1C060	B4	03						
	PM75RG1AP065	R	09							PM75B5L1C060	B5	03						
										PM75B6L1C060	B6	03						
100	PM100CG1A065	C	12	PM100CL1A060	C	01	PM100CS1D060	C	05				PM100CLA060	C				
	PM100CG1B065	C	10							PM100CL1B060	C	02			PM100RLA060	R		
	PM100RG1B065	R	10							PM100RL1A060	R	01						
	PM100CG1AL065	C	12							PM100RL1B060	R	02						
	PM100CG1AP065	C	09															
PM100CG1APL065	C	09																
150	PM150CG1B065	C	10	PM150CL1A060	C	01	PM150CS1D060	C	05				PM150CLA060	C				
	PM150RG1B065	R	10	PM150CL1B060	C	02				PM150RLA060	R							
				PM150RL1A060	R	01												
			PM150RL1B060	R	02													
200	PM200CG1B065	C	10	PM200CL1A060	C	04	PM200CS1D060	C	05				PM200CLA060	C				
	PM200RG1B065	R	10							PM200RL1A060	R	04			PM200RLA060	R		
	PM200CG1C065	C	11															
	PM200RG1C065	R	11															
300	PM300CG1C065	C	11	PM300CL1A060	C	04						PM300CLA060	C					
	PM300RG1C065	R	11	PM300RL1A060	R	04					PM300RLA060			R				
400/450	PM450CG1C065	C	11							PM400DV1A060	D	06		PM450CLA060	C	08		
600	PM450RG1C065	R	11							PM600DV1A060	D	06		PM600CLA060	C	08		
800										PM800DV1B060	D	07						
IGBT chip	CSTBT*1		CSTBT*1		CSTBT*1		CSTBT*1		CSTBT*1		CSTBT*1		CSTBT*2					
	Emitter sensor installed Temperature sensor installed		Built-in emitter sensor Built-in temperature sensor		Built-in emitter sensor Built-in temperature sensor		Built-in emitter sensor Built-in temperature sensor		Built-in emitter sensor Built-in temperature sensor		Built-in emitter sensor Built-in temperature sensor		Built-in emitter sensor Built-in temperature sensor					
Fault output	UV	P-side/N-side		P-side/N-side		N-side		P-side/N-side		P-side/N-side		P-side/N-side						
	OT	P-side/N-side		P-side/N-side		N-side		P-side/N-side		P-side/N-side		P-side/N-side						
	SC	P-side/N-side		P-side/N-side		N-side		P-side/N-side		P-side/N-side		P-side/N-side						
Identification	P-side/N-side		-		-		-		-		-							
RoHS directive	Compliant		Compliant		Compliant		Compliant		Compliant		Compliant							
Compatibility	-		L Series		S-DASH SERVO		V Series		-		-							
Connection	D			B4			B5			B6			C			R		

Not recommended : Please contact to the sales offices.

[Notes] *1: Full-gate CSTBT™ *2: PCM (Plugged Cell Merged) CSTBT™

[Term] UV: Power supply Under Voltage protection
 SC: Short Circuit protection
 OT: Over Temperature protection
 OC: Over current protection
 RoHS: Restriction of hazardous substances in electrical and electronic equipment

■ Matrix of IPM Modules 1200V (No.: Number of outline drawing, see page 11 to 12)

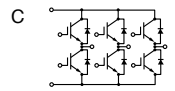
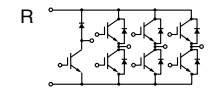
V _{CE} (V)		1200V													
Series	G1 Series			L1 Series			S1 Series			V1 Series			L Series		
	I _C (A)	Connection	No.	Connection	No.	Connection	No.	Connection	No.	Connection	No.	Connection	No.		
25	PM25CG1A120	C	12												
	PM25CG1B120	C	10												
	PM25RG1A120	R	12	PM25CL1A120	C	01						PM25CLA120	C		
	PM25RG1B120	R	10	PM25CL1B120	C	02						PM25CLB120	C		
	PM25CG1AL120	C	12	PM25RL1A120	R	01	PM25CS1D120	C	05			PM25RLA120	R		
	PM25CG1AP120	C	09	PM25RL1B120	R	02						PM25RLB120	R		
	PM25CG1APL120	C	09	PM25RL1C120	R	03									
	PM25RG1AP120	R	09												
35	PM35CG1A120	C	12												
	PM35CG1B120	C	10												
	PM35RG1A120	R	12												
	PM35RG1B120	R	10												
	PM35CG1AL120	C	12												
	PM35CG1AP120	C	09												
	PM35CG1APL120	C	09												
	PM35RG1AP120	R	09												
50	PM50CG1A120	C	12												
	PM50CG1B120	C	10	PM50CL1A120	C	01						PM50CLA120	C		
	PM50RG1B120	R	10	PM50CL1B120	C	02						PM50CLB120	C		
	PM50CG1AL120	C	12	PM50RL1A120	R	01	PM50CS1D120	C	05			PM50RLA120	R		
	PM50CG1AP120	C	09	PM50RL1B120	R	02						PM50RLB120	R		
	PM50CG1APL120	C	09												
75	PM75CG1B120	C	10	PM75CL1A120	C	01						PM75CLA120	C		
	PM75RG1B120	R	10	PM75CL1B120	C	02						PM75CLB120	C		
				PM75RL1A120	R	01	PM75CS1D120	C	05			PM75RLA120	R		
				PM75RL1B120	R	02						PM75RLB120	R		
100	PM100CG1B120	C	10												
	PM100CG1C120	C	11	PM100CL1A120	C	04						PM100CLA120	C		
	PM100RG1B120	R	10	PM100RL1A120	R	04	PM100CS1D120	C	05			PM100RLA120	R		
	PM100RG1C120	R	11												
150	PM150CG1C120	C	11	PM150CL1A120	C	04						PM150CLA120	C		
	PM150RG1C120	R	11	PM150RL1A120	R	04						PM150RLA120	R		
200	PM200CG1C120	C	11							PM200DV1A120	D	06	PM200CLA120	C	
	PM200RG1C120	R	11												
300										PM300DV1A120	D	06	PM300CLA120	C	
450										PM450DV1A120	D	06	PM450CLA120	C	
IGBT chip	CSTBT*1 Emitter sensor installed Temperature sensor installed			CSTBT*1 Built-in current sensor Built-in temperature sensor			CSTBT*1 Built-in current sensor Built-in temperature sensor			CSTBT*1 Built-in current sensor Built-in temperature sensor			CSTBT*2 Built-in current sensor Built-in temperature sensor		
	Fault output	UV	P-side/N-side		P-side/N-side		N-side		P-side/N-side		P-side/N-side		P-side/N-side		
	OT	P-side/N-side		P-side/N-side		N-side		P-side/N-side		P-side/N-side		P-side/N-side			
	SC	P-side/N-side		P-side/N-side		N-side		P-side/N-side		P-side/N-side		P-side/N-side			
Identification		P-side/N-side		—		—		—		—		—			
RoHS directive		Compliant		Compliant		Compliant		Compliant		Compliant		Compliant			
Compatibility		—		L Series		S-DASH SERVO		V Series		—		—			
Connection		D		C		R									

Not recommended : Please contact to the sales offices.

[Notes] *1: Full-gate CSTBT™ *2: PCM (Plugged Cell Merged) CSTBT™

[Term] UV: Power supply Under Voltage protection
 SC: Short Circuit protection
 OT: Over Temperature protection
 OC: Over current protection
 RoHS : the Restriction of the use of certain Hazardous Substances in electrical and electronic equipment



Featured Products

New lineup contributes to simple design downsizing, energy-savings of industrial inverters.

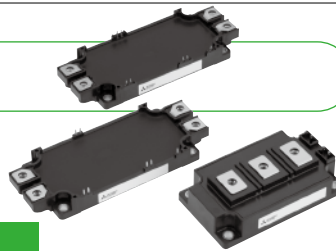

Data sheet here



NX type



std type

IGBT Module T/T1-Series

<Main Features>

- New modules equipped with three-phase converter, inverter, and brake circuit(CIB), contributes to simplifying design for inverter systems
- CIB modules contribute to compact inverter systems by reducing package size by 36% compared to the Mitsubishi Electric's existing module.(CIB)
- Power loss has been reduced with the introduction of the 7th-generation IGBT produced using CSTBT™² and a diode incorporating a relaxed field of cathode (RFC) structure
- The new structure introduced eliminates the solder-attached section, increasing the thermal cycle lifetime, which contributes to improving the reliability of inverters
- The introduction of press-fit pins and PC-TIM¹ contribute to simplifying the assembly process for inverters

*1 PC-TIM: Phase change - thermal interface material

*2 CSTBT™: Mitsubishi Electric's unique IGBT that makes use of the carrier cumulative effect

New structure realizes improved reliability (improved thermal cycle lifetime)

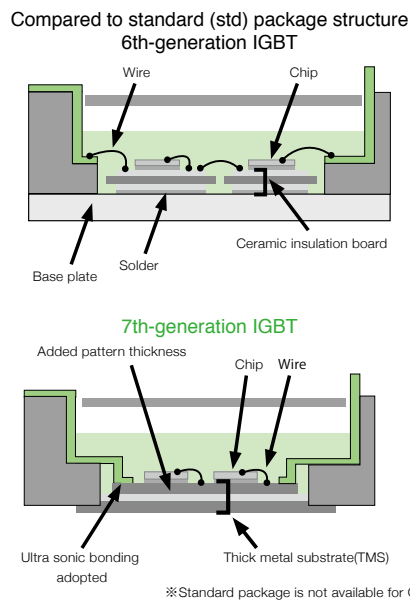
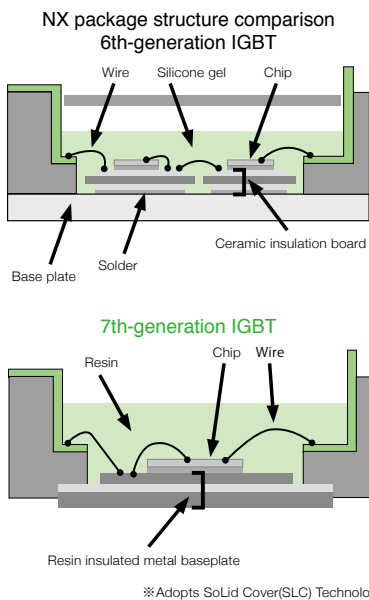

Press-fit terminal support (NX)

- Possible to select the control pin shape (soldered terminals/press-fit terminals)
- Solder attachment process eliminated

Press-fit pin

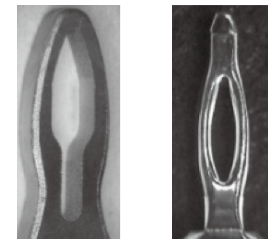

① Main pin

② Signal pin



New Products Under Development

Industrial IGBT module with new standard package "LV100" for high power density inverter, have been developed for the application that high-density inverter is required.

IGBT module T-series (LV100 for industrial)

IGBT module 2in1 type

■ Lineup

800A/1700V, 800A/1700V(with enhanced FWD), 1200A/1700V

<Main Features>

- Next generation high capacity standard package for industrial use
- Improved ease of use by applying low impedance package
- Reducing the switching loss and optimal for the applications that are used in 1 to 5KHz
- Isolation voltage 4kV

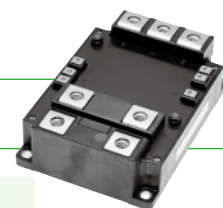
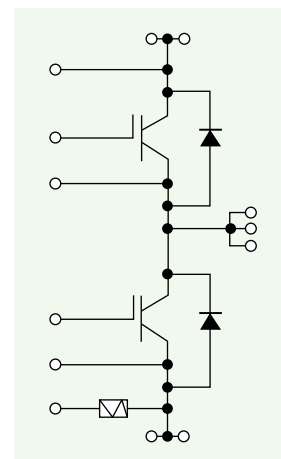



Featured Products

Contributes to realizing smaller, energy-saving large-capacity inverters



1-in-1 / 2-in-1 type

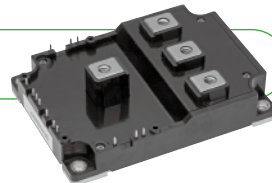

4-in-1 type

Data sheet here



Power Modules for 3-level Inverters

<Main Features>

- Compatible with 3-level inverters, reducing power consumption approx. 30%^{*1}
- New package developed^{*2} contributing to lower inductance and simplified inverter circuit structure
- IGBT specifications optimized^{*3} with development of new compact, low-inductance package
- 4-in-1^{*4} and 1-in-1/2-in-1^{*5} lineup contributes to improved compactness and freedom in inverter design

^{*1} Comparison between 3-level inverter incorporated in this device and 2-level inverter in conventional device.

^{*2} 1-in-1/2-in-1 type external dimensions of 130x67mm, 4-in-1 type external dimensions of 115x82mm, new package developed with innovative terminal positioning.

^{*3} IGBT specifications optimized for 3-level inverters, adopting CSTBT[™] (Mitsubishi Electric's unique IGBT that makes use of the carrier cumulative effect).

^{*4} 4-in-1 module with one 3-level inverter arm in one package.

^{*5} Bidirectional switch model as emitter common connection.

Internal circuit diagram

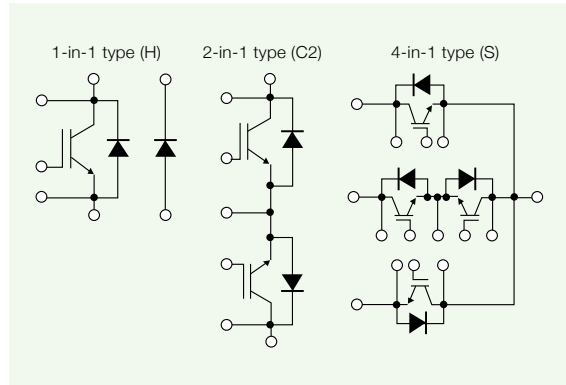

Lineup

General use for 3Level inverter			Model	Module type	Rated voltage	Rated current	Circuit structure	External dimensions WxD(mm)						
Circuit topology	Inverter range	Function												
T type	125kW~630kW	-	CM400ST-24S1	IGBT	1200V	400A	4in1	115x82						
		BRIDGE	CM450DY-24T			450A	2in1							
		AC Switch	CM450C1Y-24T			600A								
		BRIDGE	CM600DY-24T											
	250kW~	AC Switch	CM500C2Y-24S		1200V	500A	2in1	130x67						
			BRIDGE		CM600HA-34S	1700V	600A		1in1					
		BRIDGE	CM800HA-34S			800A								
		BRIDGE	CM1000HA-34S			1000A								
		AC Switch	CM400DY-34T		1700V	400A	2in1			108x62				
			BRIDGE		CM450C1Y-24T	1200V			450A					
			BRIDGE		CM300DY-34T	1700V			300A					
			AC Switch		CM600C1Y-24T	1200V			600A					
			I type		500kW~	-			CM1400HA-24S		1200V	1400A	1in1	130x67
						Clamp Diode			RM1400HA-24S		1700V	600A	2in1	108x62
Clamp Diode	RM600DY-34S													
Clamp Diode	RM800DY-34S													

Features of IGBT Module Series

S Series

- Lineup includes various package types
- 6th-generation CSTBT[™] delivers low-loss performance
- Thinner package (Height: 17mm) (NX type)
- Suited to large-capacity applications (MPD type)

MPD: Mega power dual

NFH Series

- High-speed CSTBT[™] delivers low-loss performance
- Soft switching (resonant) turn-off function (ZVS)
- Enhanced inner wiring (skin effect)

CSTBT[™]: Mitsubishi Electric's unique IGBT that makes use of the carrier cumulative effect.

Typical circuit of 3level inverter

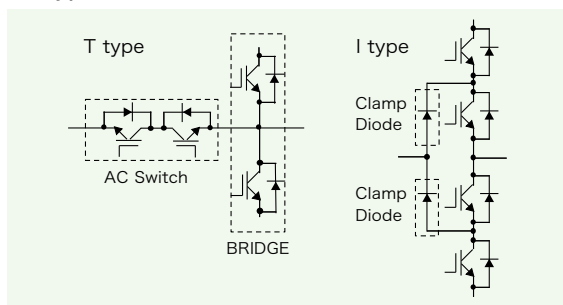

Type Name Definition of IGBT Modules

CM 600 D Y -13 T

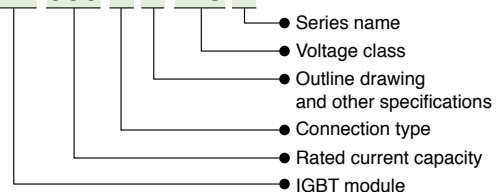

Line-up of IGBT Modules

■ Matrix of IGBT Modules 650V/600V (No.: Number of outline drawing, see page 18 to 23)

RoHS directive (2011/65/EU, (EU)2015/863) compliant

V _{CEs} (V)	650V						600V																	
	T/T1-Series NX Type		Connection	No.	T-Series std Type		Connection	No.	A-Series NX Type		Connection	No.	NF-Series		Connection	No.	NF-Series NFH Type		Connection	No.				
50	CM50MXUB-13T*	M			42																			
	CM50MXUB-13T1*	M	42																					
	CM50MXUBP-13T*	M	46																					
	CM50MXUBP-13T1*	M	46																					
75	CM75MXUB-13T*	M	42					CM75MX-12A	M	01			CM75TL-12NF	T	07									
	CM75MXUB-13T1*	M	42																					
	CM75MXUBP-13T*	M	46																					
	CM75MXUBP-13T1*	M	46																					
100	CM100TX-13T	T	33	CM100DY-13T	D	30		CM100MX-12A	M	01			CM100TL-12NF	T	07									
	CM100TXP-13T	T	37																					
	CM100MXUB-13T*	M	42																					
	CM100MXUB-13T1*	M	42																					
	CM100MXUBP-13T*	M	46																					
	CM100MXUBP-13T1*	M	46																					
	CM100MXUD-13T*	M	44																					
	CM100MXUD-13T1*	M	44																					
	CM100MXUDP-13T*	M	48																					
	CM100MXUDP-13T1*	M	48																					
150	CM150TX-13T	T	33	CM150DY-13T	D	30		CM150RX-12A	R	02			CM150DY-12NF	D	08									
	CM150TXP-13T	T	37																					
	CM150RX-13T	R	34																					
	CM150RXP-13T	R	38																					
	CM150MXUD-13T*	M	44																					
	CM150MXUD-13T1*	M	44																					
	CM150MXUDP-13T*	M	48																					
	CM150MXUDP-13T1*	M	48																					
200	CM200TX-13T	T	33	CM200DY-13T	D	30		CM200RX-12A	R	02			CM200DY-12NF	D	08									
	CM200TXP-13T	T	37																					
	CM200RX-13T	R	34																					
	CM200RXP-13T	R	38																					
225																								
300	CM300DX-13T	D	28	CM300DY-13T	D	31		CM300DX-12A	D	03			CM300DY-12NF	D	08						CM300DU-12NFH	D	14	
	CM300DXP-13T	D	39																					
400				CM400DY-13T	D	31		CM400DX-12A	D	03			CM400DY-12NF	D	10							CM400DU-12NFH	D	14
450	CM450DX-13T	D	28																					
	CM450DXP-13T	D	39																					
600	CM600DX-13T	D	28	CM600DY-13T	D	32							CM600DY-12NF	D	11							CM600DU-12NFH	D	15
	CM600DXP-13T	D	39																					
1000																								
Connection																								

★: New Product

■ Matrix of Power Modules for 3-level Inverter (No.: Number of outline drawing, see page 19 to 21)

RoHS directive (2011/65/EU, (EU)2015/863) compliant

V _{CEs} /V _{VRM}	1200 V IGBT Module			1700 V IGBT Module			1200 V Diode Module			1700 V Diode Module		
	T/S/S1-Series std Type		Connection	No.	S/S1-Series std Type		Connection	No.	S/S1-Series std Type		Connection	No.
400	CM400ST-24S1	S			35							
	CM400C1Y-24S	C1	11									
450	CM450C1Y-24T*	C1	32									
500	CM500C2Y-24S	C2	36									
600	CM600C1Y-24T	C1	32									
												CM600HA-34S
800												
												CM800HA-34S
1000												
1400	CM1400HA-24S	H	36									
												RM1400HA-24S*
Connection												

*Connection of diode module and IGBT module are different.

★: New Product

Line-up of IGBT Modules

Matrix of IGBT Modules 1700V (No.: Number of Outline Drawing, see page 18 to 23)

RoHS directive (2011/65/EU, (EU)2015/863) compliant

V _{CE} (V)		1700V																			
Series	T-Series LV100 Type			T-Series NX Type			T-Series std Type			S/S1-Series NX Type			S/S1-Series std Type			S/S1-Series MPD Type			A-Series std Type		
	I _c	Connection	No.	Connection	No.	Connection	No.	Connection	No.	Connection	No.	Connection	No.	Connection	No.	Connection	No.	Connection	No.		
75						CM75DY-34T*	D	30	CM75MXA-34SA CM75RX-34SA	M R	23 19							CM75DY-34A	D	08	
100				CM100TX-34T* CM100XP-34T*	T T	33 37	CM100DY-34T*	D	30									CM100DY-34A	D	08	
150				CM150TX-34T* CM150XP-34T*	T T	33 37	CM150DY-34T*	D	31	CM150DX-34SA CM150RXL-34SA	D R	20 21						CM150DY-34A	D	10	
200							CM200DY-34T*	D	31	CM200DX-34SA CM200EXS-34SA	D E	20 24						CM200DY-34A	D	10	
225				CM225DX-34T* CM225XP-34T*	D D	28 39															
300				CM300DX-34T* CM300XP-34T*	D D	28 39	CM300DY-34T*	D	32	CM300DX-34SA	D	20						CM300DY-34A	D	11	
400							CM400DY-34T*	D	32									CM400DY-34A	D	18	
450				CM450DX-34T* CM450XP-34T*	D D	28 39			CM450DXL-34SA	D	22										
500																		CM500HA-34A	H	16	
600				CM600DX-34T* CM600XP-34T*	D D	28 39			CM600DXL-34SA	D	22	CM600HA-34S	H	36							
800	CM800DW-34T** CM800DW-34TA**	D D	- -									CM800HA-34S	H	36							
1000												CM1000HA-34S	H	36	CM1000DUC-34SA	D	17				
1200	CM1200DW-34T**	D	-																		

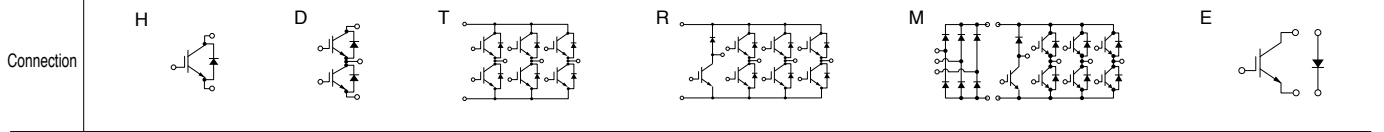

★★: Under Development ★: New Product

01 CM75,100MX-12A

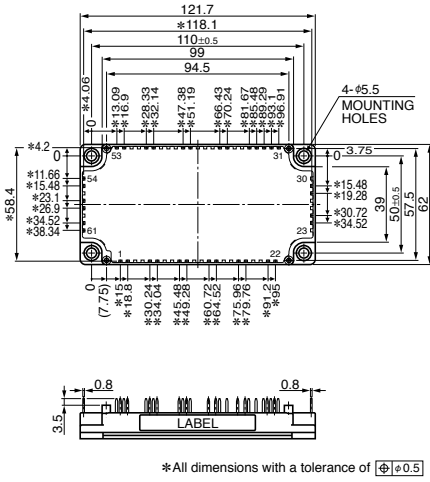

02 CM100,150,200RX-12A
CM75RX-24S

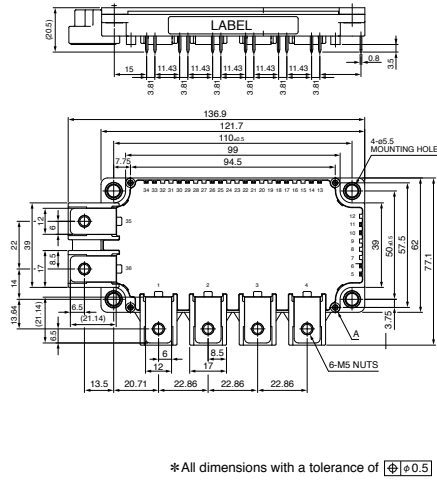

03 CM300,400DX-12A
CM150,200DX-24S

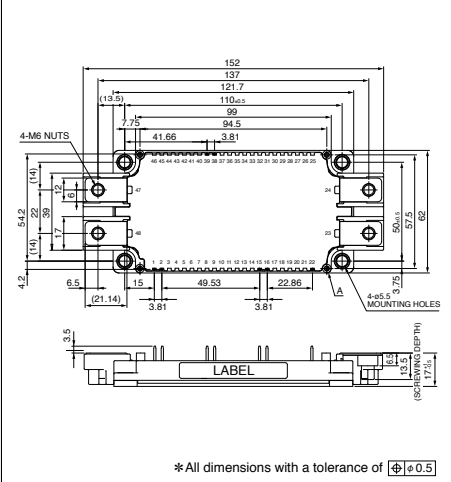

04 CM35,50,75,100MXA-24S

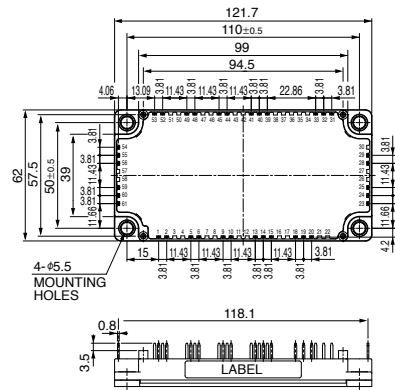

05 CM75TX-24S

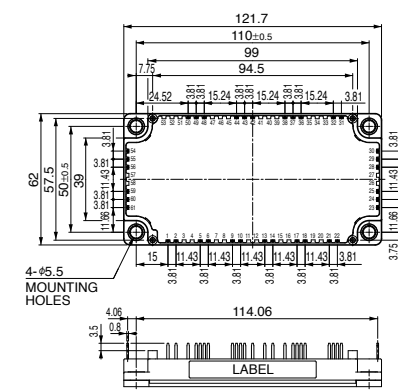

06 CM600,1000DXL-24S

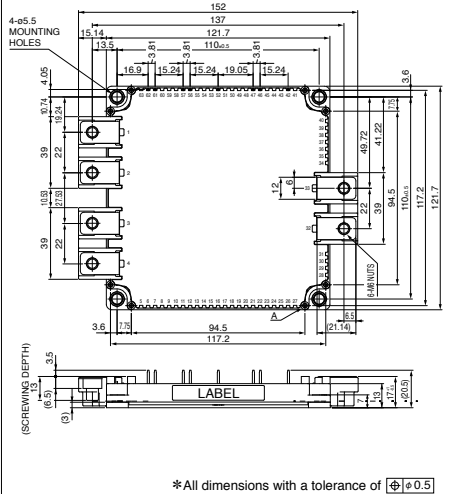

07 CM75,100,150TL/RL-12NF
CM50,75,100TL/RL-24NF

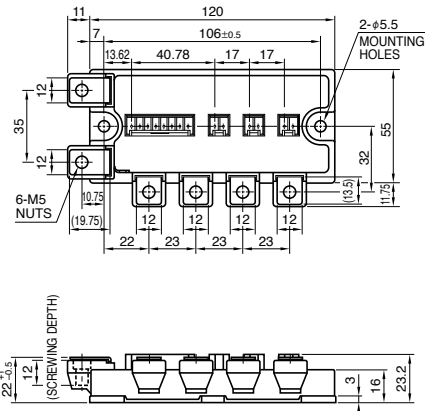

08 CM150,200,300DY-12NF
CM100,150DY-24NF
CM100,150,200DY-24A
CM75,100DY-34A
CM100,150E3Y-24NF

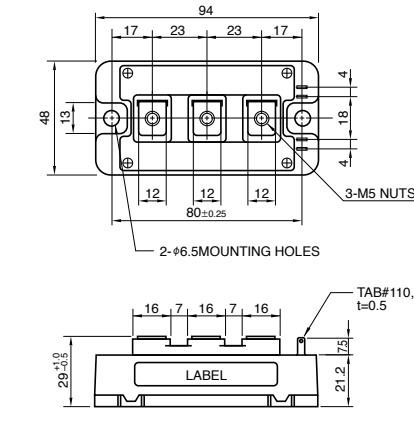

09 CM200TL/RL-12NF
CM150,200TL/RL-24NF

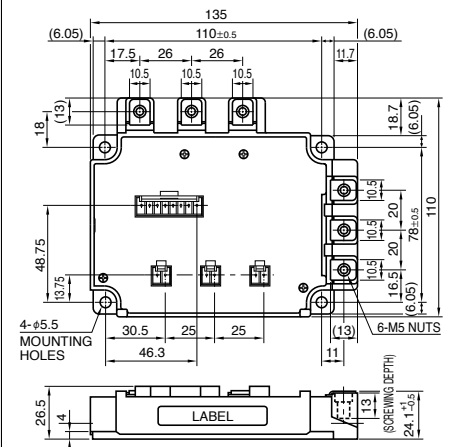

Line-up of IGBT Modules

Outline Drawing of IGBT Modules

Unit:mm

10

CM400DY-12NF
CM200DY-24NF
CM300DY-24A
CM300DY-24S
CM150,200DY-34A

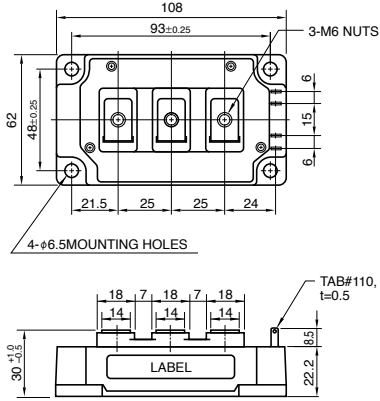

11

CM600DY-12NF CM400C1Y-24S
CM400DY-24NF CM450DY-24S
CM400,600DY-24A CM600DY-24S
CM300DY-34A CM300DY-24NF

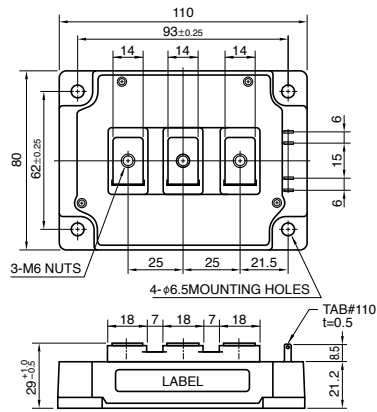

12

CM600DU-24NF
CM800DY-24S

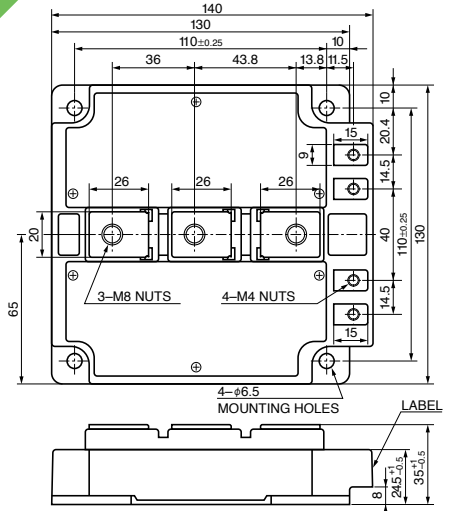

13

CM200DU-12NFH
CM100,150DU-24NFH

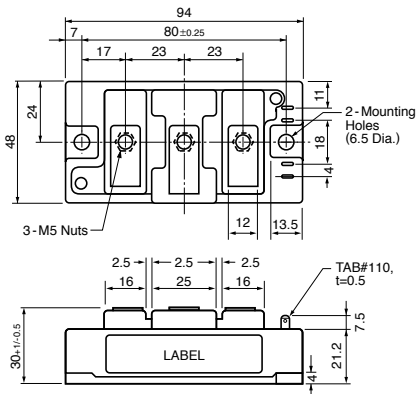

14

CM300,400DU-12NFH
CM200,300DU-24NFH

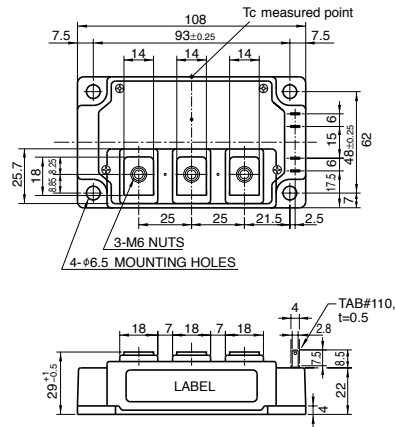

15

CM600DU-12NFH
CM400,600DU-24NFH

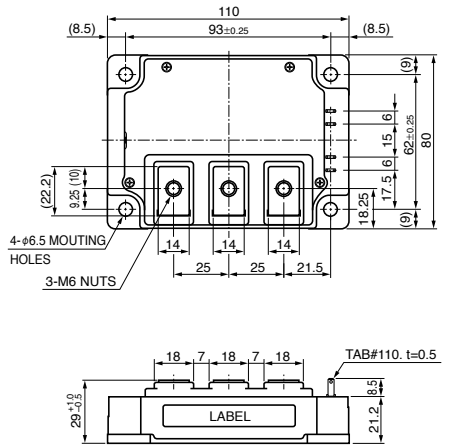

16

CM400,600HA-24A
CM500HA-34A

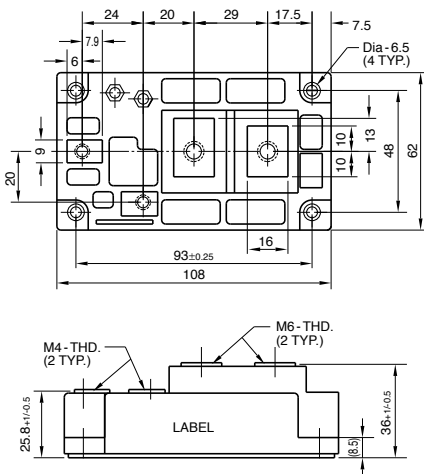

17

CM900,1400DUC-24S
CM1000DUC-34SA

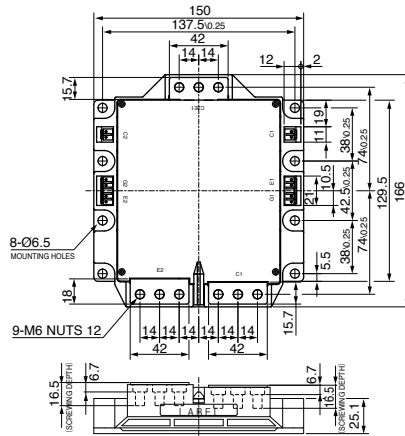

18

CM400DY-34A

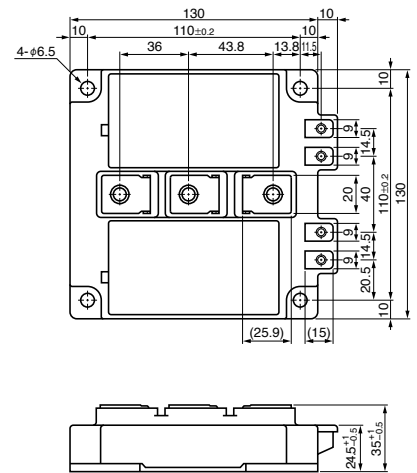

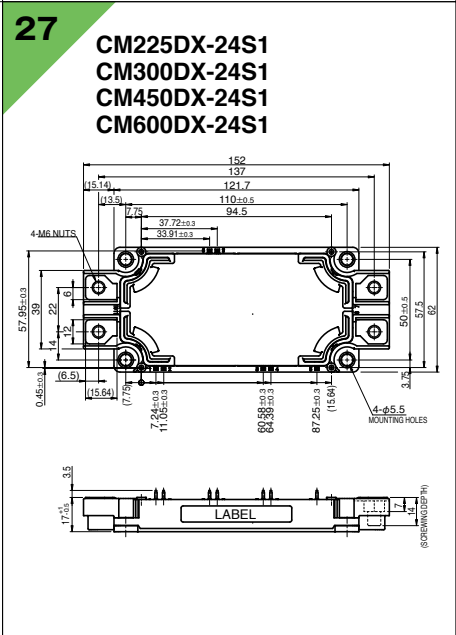
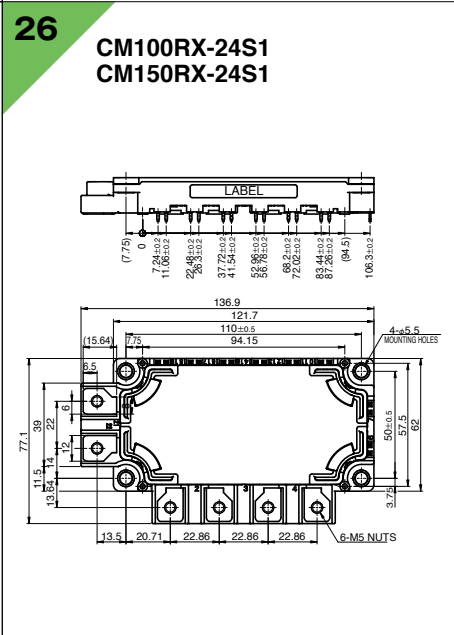
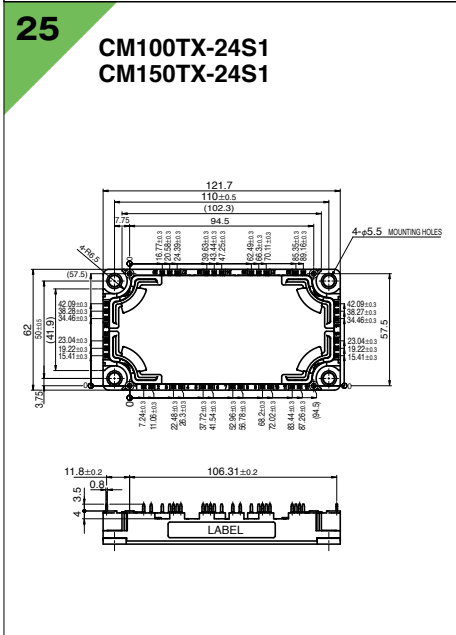
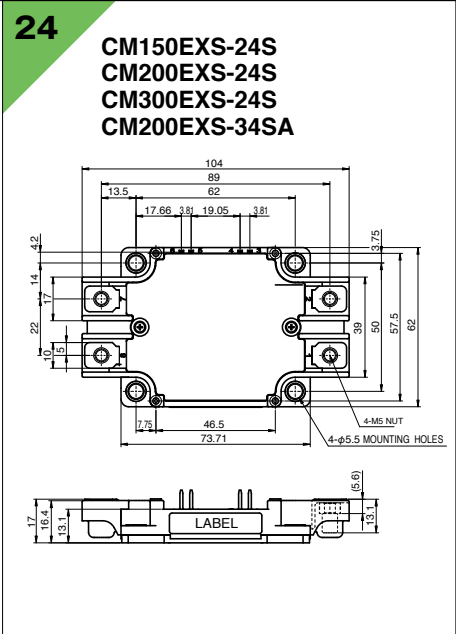
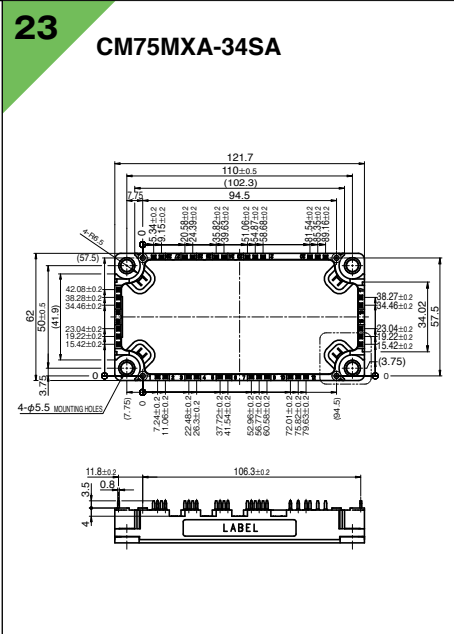
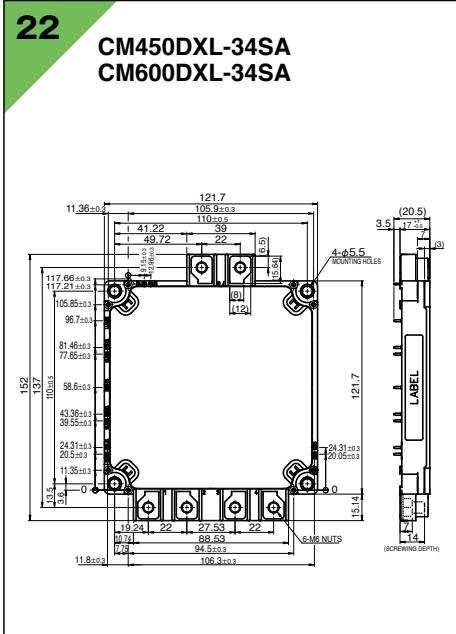
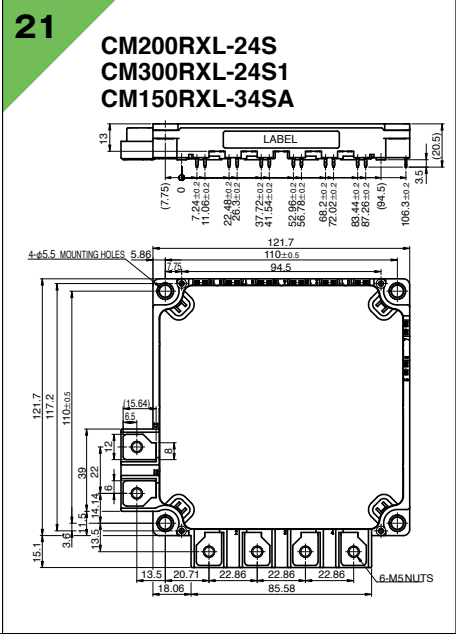
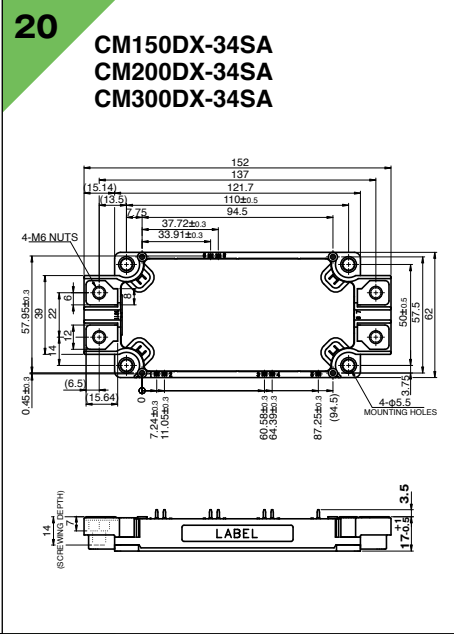
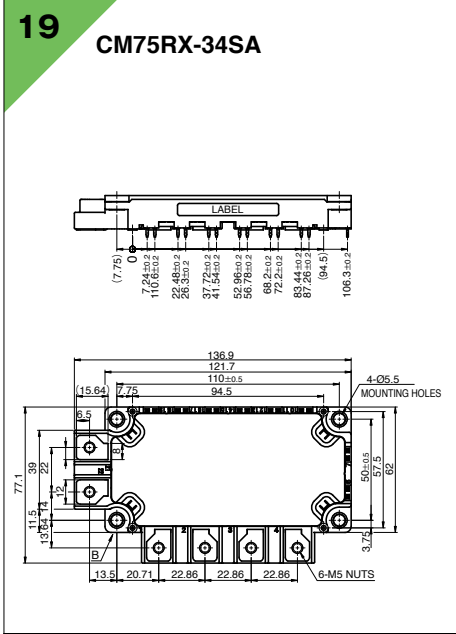

Line-up of IGBT Modules

Outline Drawing of IGBT Modules

Unit:mm

28

CM300,450,600DX-13T
CM225,300,450,600DX-24T
CM800DX-24T1

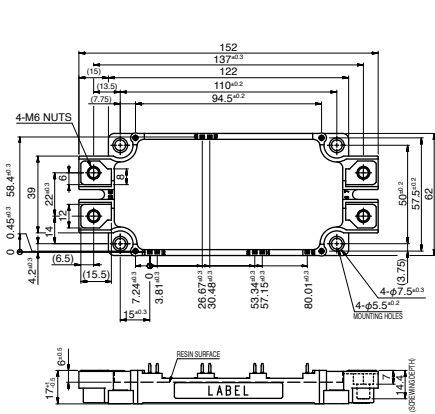

29

CM1000DX-24T

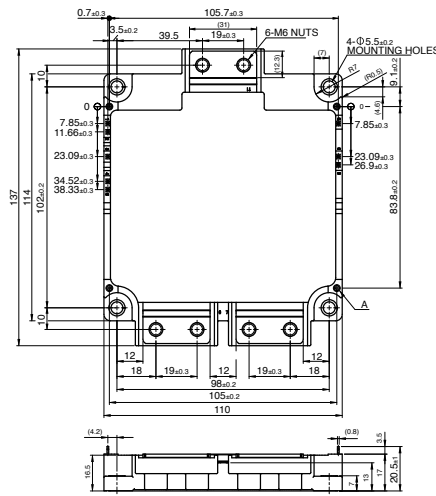

30

CM100,150,200DY-13T
CM100,150DY-24T

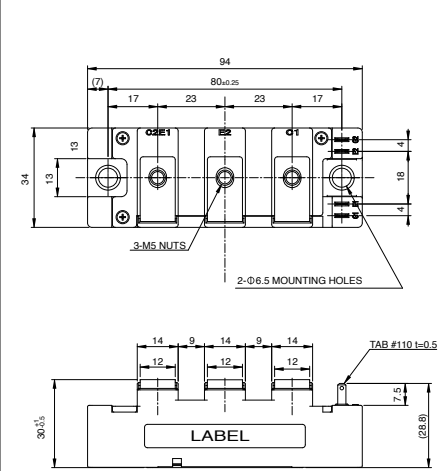

31

CM300,400DY-13T
CM200,300DY-24T

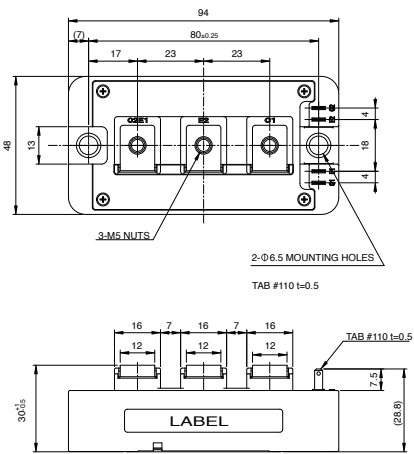

32

CM600DY-13T
CM450,600DY-24T
CM450,600C1Y-24T

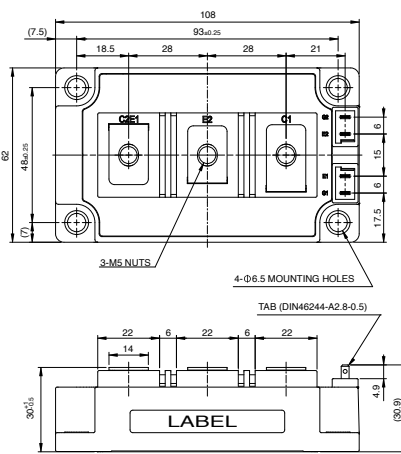

33

CM100,150,200TX-13T
CM100,150,200TX-24T
CM100,150TX-34T

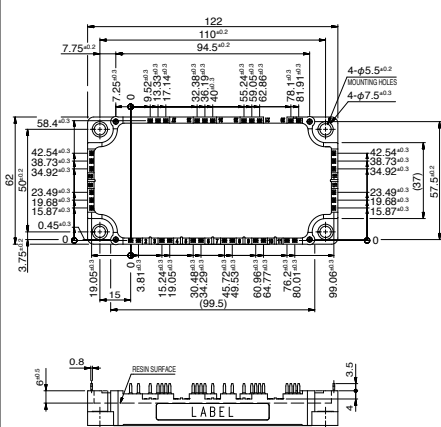

34

CM150,200RX-13T
CM100,150RX-24T

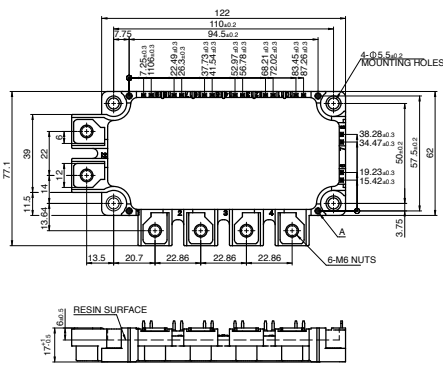

35

CM400ST-24S1

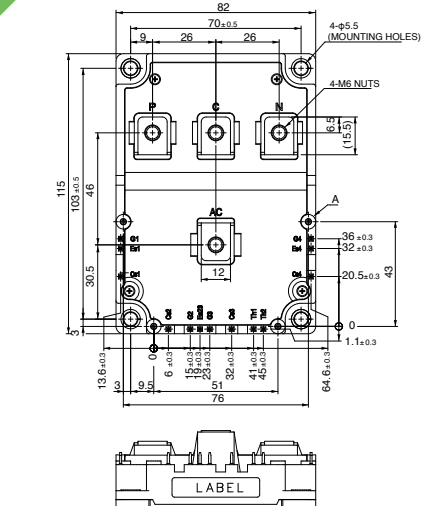

36

CM500C2Y-24S
CM1400HA-24S
CM1000HA-34S
RM1400HA-24S

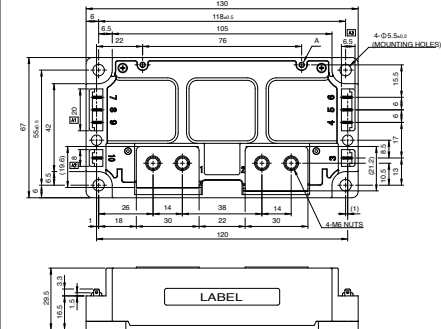

37

CM100,150,200TXP-13T
CM100,150,200TXP-24T
CM100,150TXP-34T

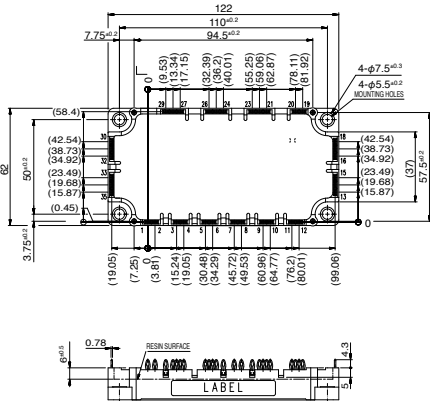

38

CM150,200RXP-13T
CM100,150RXP-24T

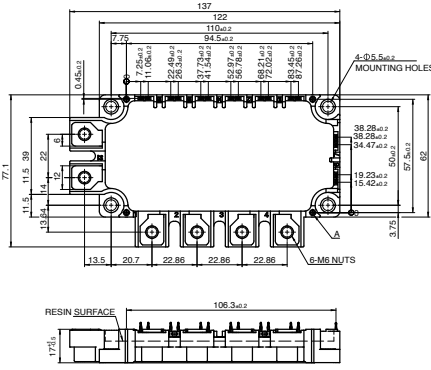

39

CM300,450,600DXP-13T
CM225,300,450,600DXP-24T
CM800DXP-24T1

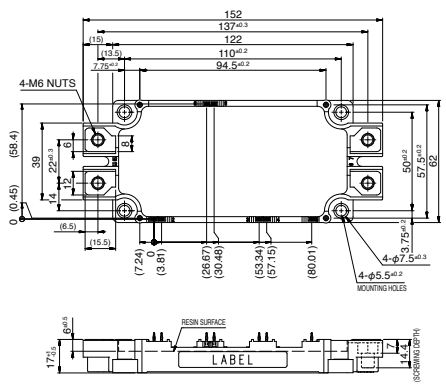

40

CM1000DXP-24T

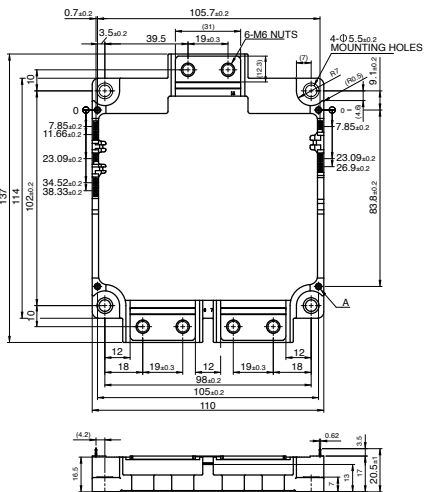

41

CM35,50MXUA-24T/24T1

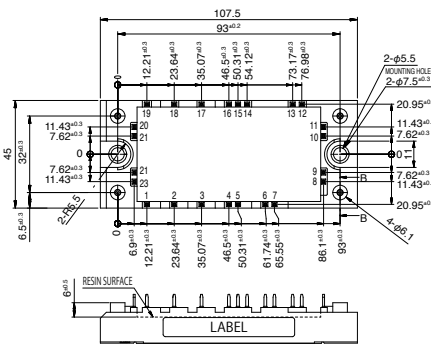

42

CM50,75,100MXUB-13T/13T1
CM75MXUB-24T/24T1

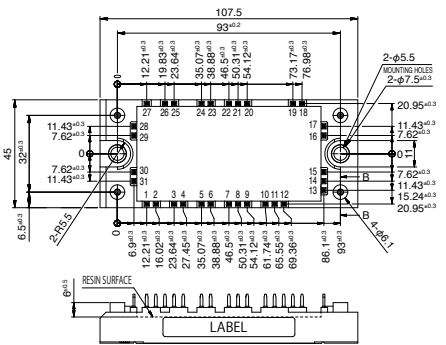

43

CM75,100MXUC-24T/24T1

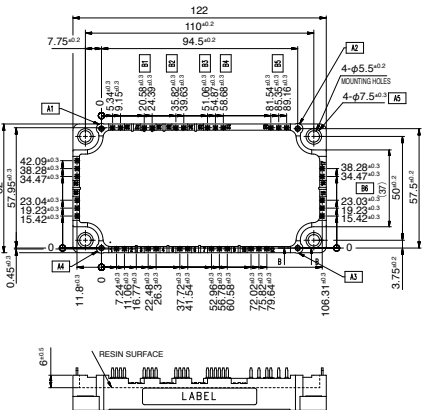

44

CM100/150MXUD-13T/T1
CM150MXUD-24T/T1

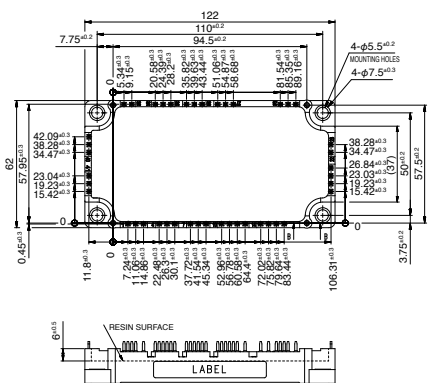

45

CM35/50MXUAP-24T/T1

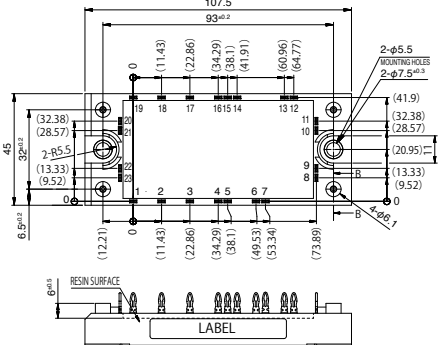

Line-up of IGBT Modules

Outline Drawing of IGBT Modules

Unit:mm

46

CM50/75/100MXUBP-13T/T1
CM75MXUBP-24T/T1

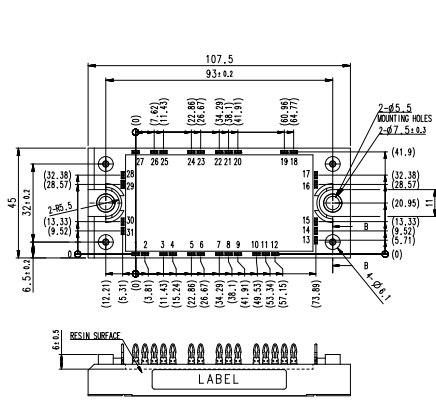

47

CM75/100MXUCP-24T/T1

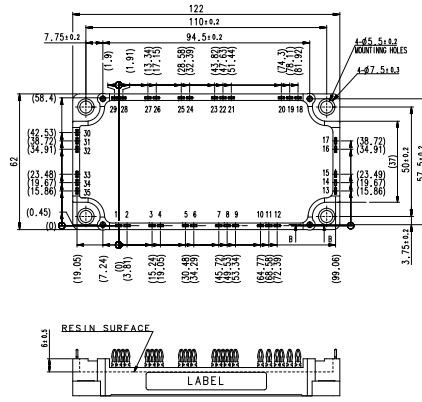

48

CM100/150MXUDP-13T/T1
CM150MXUDP-24T/T1

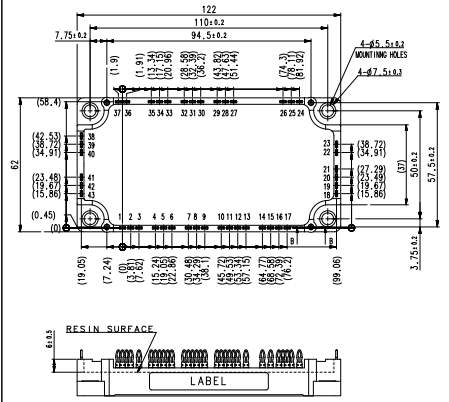



New Products

X Series HVIGBT Modules std type

Existing compatible package: Standard type Contributes to smaller, higher-capacity inverter systems by expanding lineup



std type

<Main Features>

- Power loss reduced by incorporating 7th-generation IGBT and RFC^{*1} diode
- Industry-leading power^{*2} for increased inverter capacity
- External size reduced 33% while maintaining the same voltage resistance and rated current as conventional products,^{*3} contributing to inverter downsizing
- Optimal package internal structure realizes improved heat dissipation, humidity resistance and flame retardance, increasing product life

*1 RFC : Relaxed field of cathode

*2 3.3kV - 6.5kV (as of Apr. 5, 2018 based on Mitsubishi Electric research)

*3 Comparison of X Series CM1200HC-66X and H Series CM1200HC-66H

Positioning from conventional series

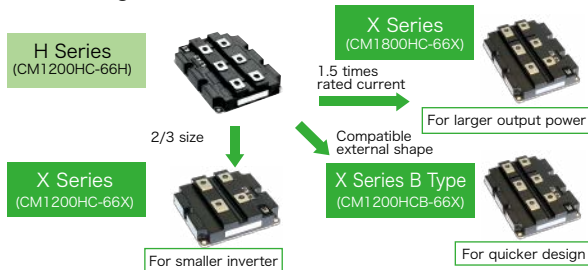

Product lineup

std Type	1.7kV	3.3kV	4.5kV	6.6kV
	1200A 1600A 2400A	1200A	900A 1000A	600A
	2400A 3600A	1200A 1800A	900A 1350A 1500A	600A 900A 1000A

Internal circuit diagram

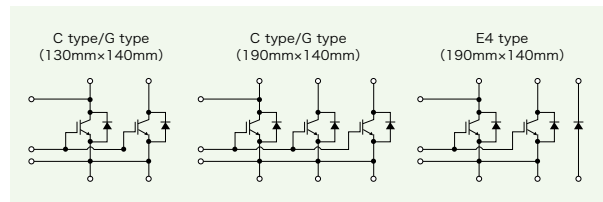

X Series HVIGBT Modules dual type

New common frame package: dual type Class-leading current density contributes to increased power output in inverter systems



dual type

<Main Features>

- Power loss reduced by incorporating 7th-generation IGBT and RFC^{*1} diode
- Industry's highest 3.3kV/600A Si module power density of 8.57A/cm²^{*4} contributes to increased power output and efficiency
- Terminal layout optimized for easy paralleling and flexible inverter configurations and capacities
- New package structure offers extra reliability

*4 As of Apr. 5, 2018, based on Mitsubishi Electric research

Product lineup

LV100	1.7kV	3.3kV	HV100	3.3kV	4.5kV	6.6kV
	1000A	450A		450A	350A	225A
	1200A	600A		600A	450A	300A

Various current ratings for optimal system design

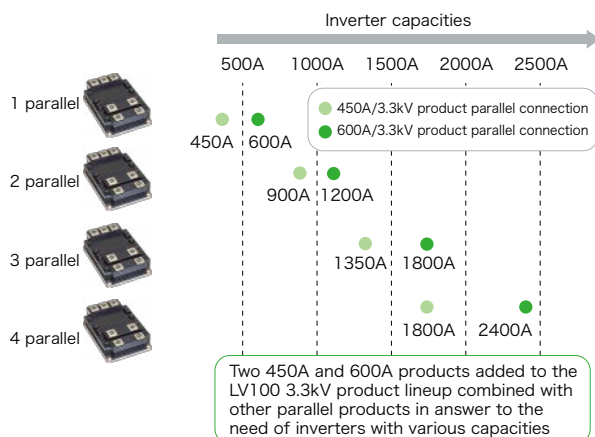

Internal circuit diagram

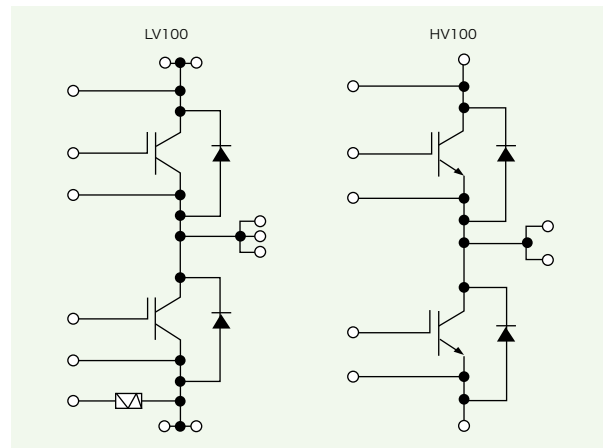

Series Matrix of HVIGBT/HVIPM(No.: Number of Outline Drawing, see page 29 to 31)

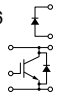
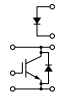
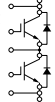
I _c (A)	V _{CEs} (V)		4500V												6500V											
	X-Series			R-Series			H-Series			X-Series			R-Series			H-Series										
	Connection	Type	No.	Connection	Type	No.	Connection	Type	No.	Connection	Type	No.	Connection	Type	No.	Connection	Type	No.								
200A																		CM200HG-130H	H	G	7					
225A													CM225DG-130X**	D2	G	21										
300A													CM300DG-130X**	D2	G	21										
350A	CM350DG-90X**	D2	G	21																						
400A																		CM400HG-130H	H	G	12					
																		CM400E2G-130H	E2	G	09					
																		CM400E4G-130H	E4	G	09					
450A	CM450DG-90X**	D2	G	21																						
600A									CM600HG-90H	H	G	12	CM600HG-130X**	H	G	18										
												CM600HGB-130X**	H	G	19											
												CM600E4G-130X	E4	G	19											
																	CM600HG-130H	H	G	11						
750A															CM750HG-130R	H	G	11								
800A								CM800HC-90R	H	C	08															
								CM800HG-90R	H	G	13															
900A	CM900HC-90X**	H	C	16																						
	CM900HG-90X**	H	G	18																						
	CM900HGB-90X**	H	G	19																						
	CM900E4G-90X**	E4	C	19																						
								CM900HG-90H	H	G	13															
								CM900HC-90H	H	C	09															
												CM900HG-130X**	H	G	19											
1000A	CM1000HG-90X**	H	G	18																						
													CM1000HG-130XA*	H	G	19										
1200A								CM1200HC-90R	H	C	10															
								CM1200HC-90RA	H	C	10															
								CM1200HG-90R	H	G	11															
1350A	CM1350HC-90X**	H	C	17																						
	CM1350HG-90X**	H	G	19																						
1500A	CM1500HC-90XA*	H	C	17																						
	CM1500HG-90X**	H	G	19																						
Connection	H 	E2/E6 	E4 	D2 																						

[Type]
 B: Cu base plate 6kV Isolation
 C: AlSiC base plate 6kV Isolation
 G: AlSiC base plate 10kV Isolation

★★: Under Development ★: New Product

Line-up of HVDIODE Modules

Series Matrix of HVDIODE Modules (No.: Number of outline drawing, see page 31)

V _{PRM} I _F (A)	1700V			3300V			4500V			6500V		
	Connection	Type	No.	Connection	Type	No.	Connection	Type	No.	Connection	Type	No.
200												
250												RM200DG-130S D G 24
300												RM250DG-130F D G 24
300									RM300DG-90S D G 24			RM300DG-130X** D G 24
400									RM400DG-66S RM400DY-66S D G 24 D B 25			RM400DG-90F D G 24
450												RM450DG-90X** D G 24
450									RM450DG-90X** D G 24			RM450DG-130X** D G 24
600									RM600DY-66S RM600DC-66X** RM600DG-66X** D B 25 D C 26 D G 24			RM600HE-90S H C 23
600									RM600HE-90S H C 23			RM600DG-130S D G 24 RM600DG-130X** D G 24
800	RM800DC-34X** D C 22											RM800DG-90F D G 24
900												RM900HC-90S H C 27 RM900DB-90S D B 27 RM900DG-90X** D G 24
1000												RM1000DC-66F D C 26
1000												RM1000DG-130XA** D G 24
1200	RM1200DB-34S RM1200DC-34X** D B 22 D C 22											RM1200DG-66S D G 24 RM1200HE-66S H C 23 RM1200DB-66S D B 27 RM1200DC-66X** D C 26 RM1200DG-66X** D G 24
1200												RM1200DG-90F D D 24
1500												RM1500HE-66F H C 23 RM1500DC-66F D C 26
1500												RM1500DC-90X** D C 26 RM1500DG-90X** D G 24
1800	RM1800HE-34S H C 23											

[Type]
 B: Cu base plate 6kV Isolation
 C: AISiC base plate 6kV Isolation
 G: AISiC base plate 10kV Isolation

★★: Under Development

Evolution of HVIGBT Module Series

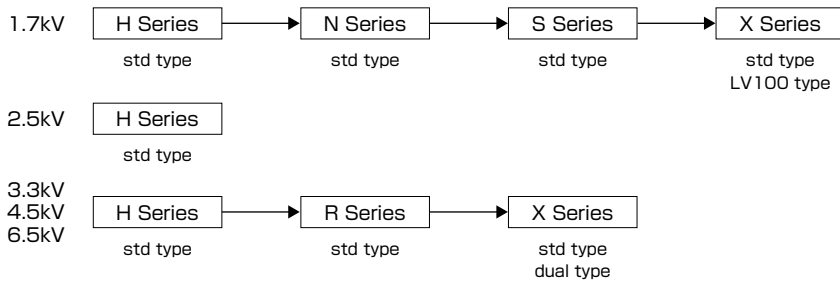

Evolution of HVDIODE Module Series

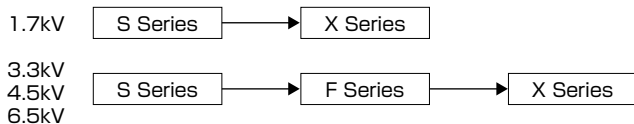

Type Name Definition of IGBT Modules

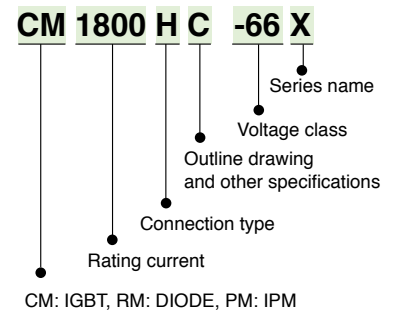

01
CM600DY-34H
CM600E2Y-34H
CM800DZ-34H
CM800DZB-34H

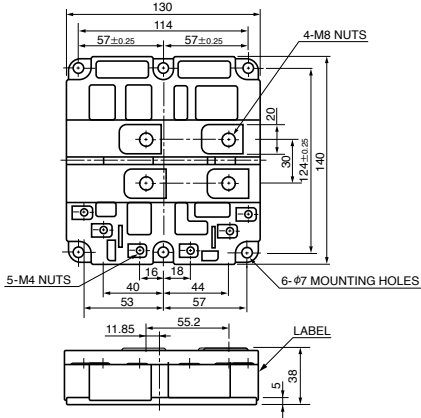

02
CM1200,1600HC-34H

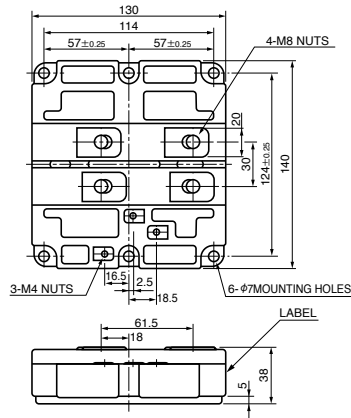

03
CM1200HCB-34N
CM800HB-50H,-66H
CM800HC-66H

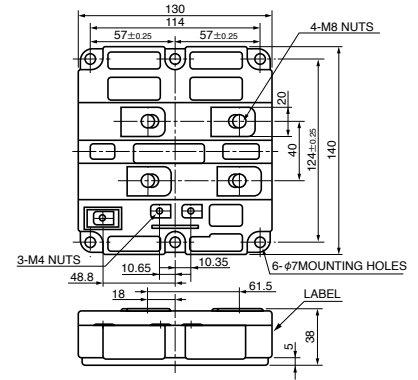

04
CM1200DB/DC-34N
CM1200DC-34S

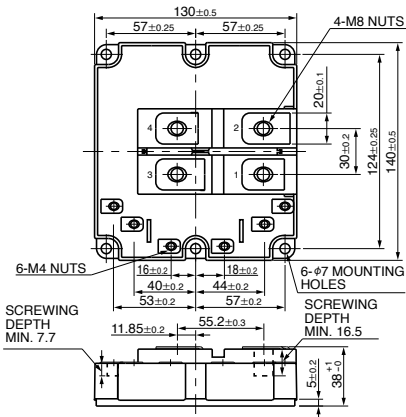

05
CM1200E4C-34N
CM1800,2400HC-34N

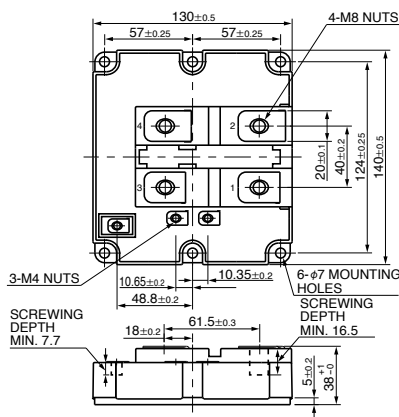

06
CM1800,2400HCB-34N
CM1800,2400HC-34H
CM1200HB/HC-50H,-66H
CM800E4C/E6C-66H
CM900HC-90H

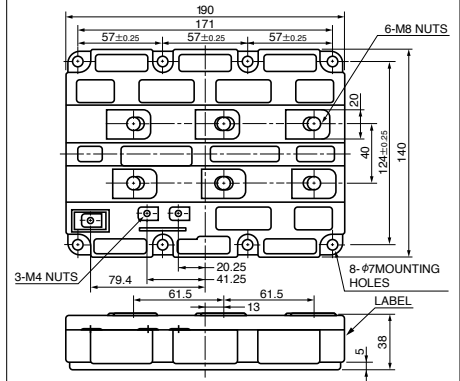

07
CM400HG-66H
CM200HG-130H

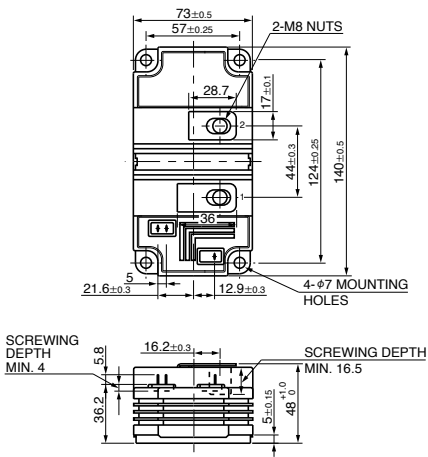

08
CM1000HC-66R
CM800HC-90R

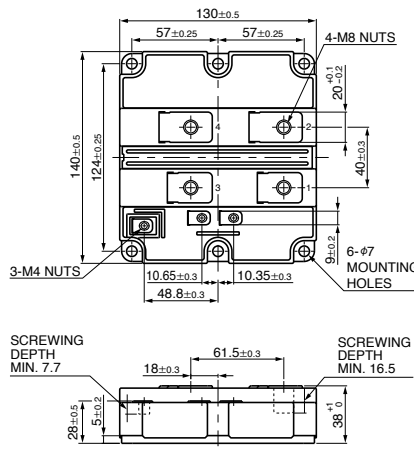

09
CM1200HG-66H
CM900HG-90H
CM400E2G/E4G-130H
CM600HG-130H

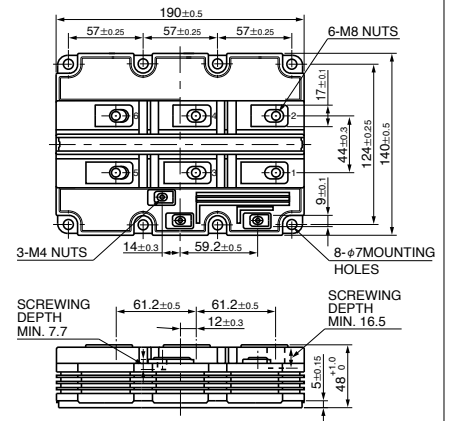

Line-up of HVIGBT Modules

Outline Drawing of HVIGBT Modules

Unit:mm

10

CM1000E4C-66R
CM1500HC-66R
CM1200HC-90R
CM1200HC-90RA

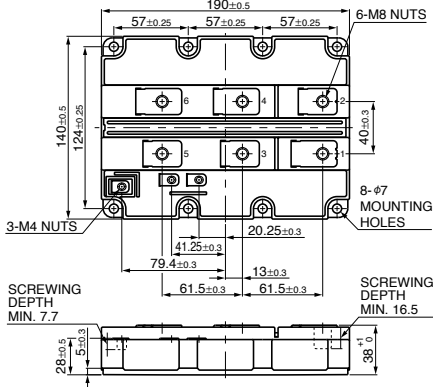

11

CM1500HG-66R
CM1200HG-90R
CM750HG-130R

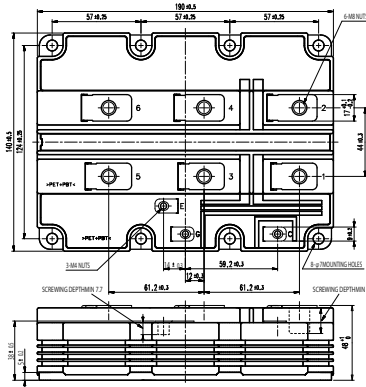

12

CM600HG-90H
CM400HG-130H

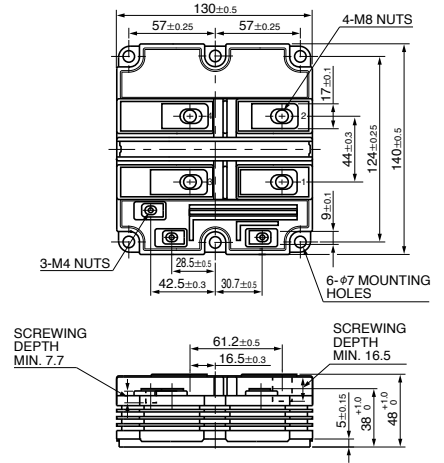

13

CM800HG-90R

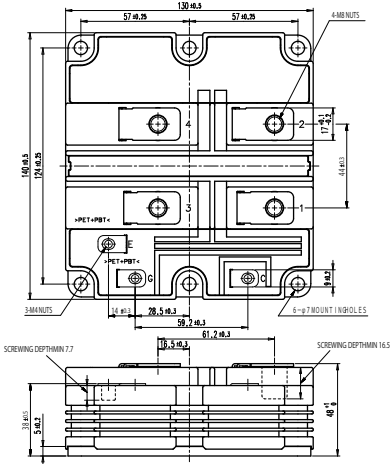

14

PM1200HCE330-1

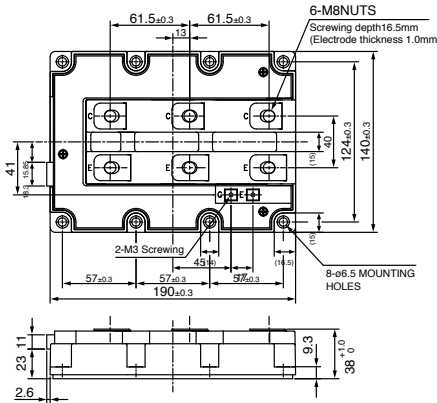

15

CM400DY-50H/66H

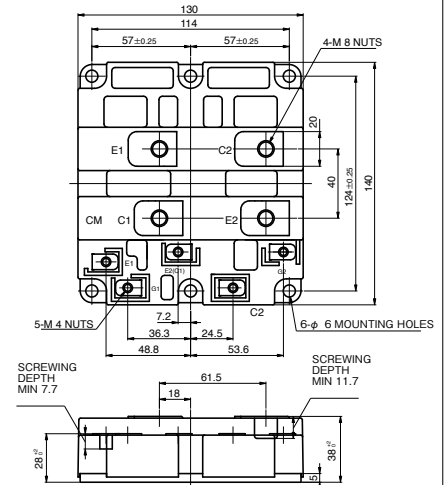

16

CM1200E4C-34X
CM1600HC-34X
CM2400HC-34X
CM1200HC-66X
CM900HC-90X

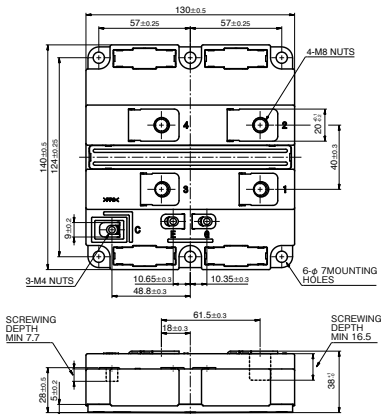

17

CM2400HCB-34X, CM3600HC-34X
CM1200E4C-66X, CM1200HCB-66X
CM1800HC-66X
CM1350HC-90X
CM1500HC-90XA

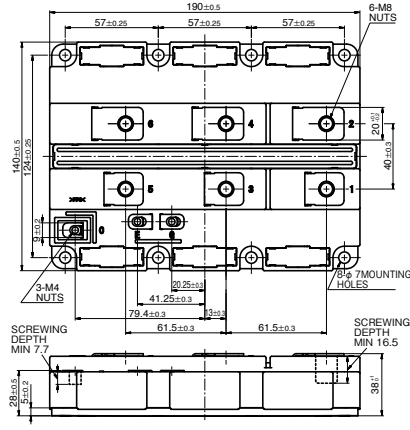

18

CM900HG-90X
CM1000HG-90X
CM600HG-130X

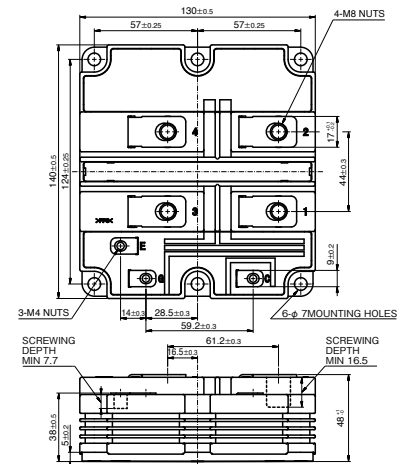

19

CM1800HG-66X
 CM900HGB-90X, CM900E4G-90X
 CM1350HG-90X, CM1500HG-90X
 CM600HGB-130X, CM600E4G-130X
 CM900HG-130X, CM1000HG-130XA

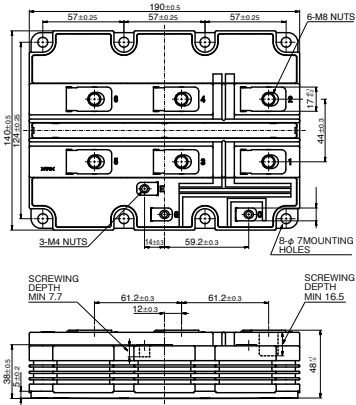

20

CM1000DC-34X
 CM1200DC-34X
 CM450DC-66X
 CM600DC-66X

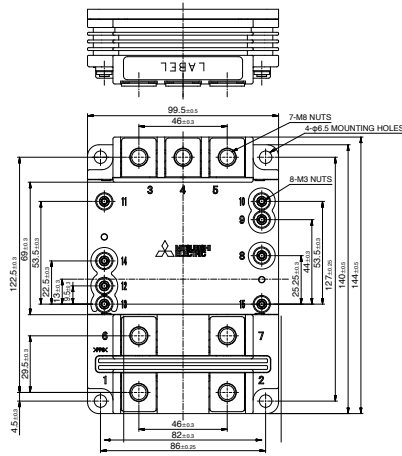

21

CM450DG-66X, CM600DG-66X
 CM350DG-90X, CM450DG-90X
 CM225DG-130X, CM300DG-130X

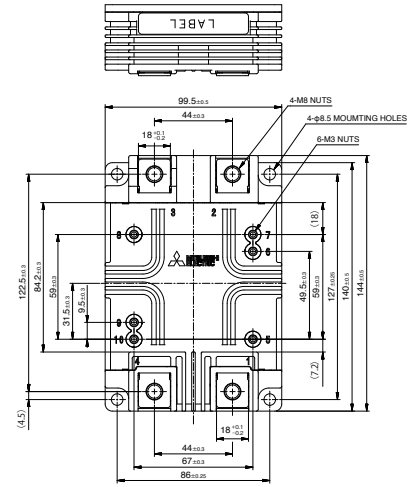

Line-up of HVDIODE Modules

Outline Drawing of HVDIODE Modules

Unit:mm

22 RM1200DB-34S
RM800DC-34X
RM1200DC-34X

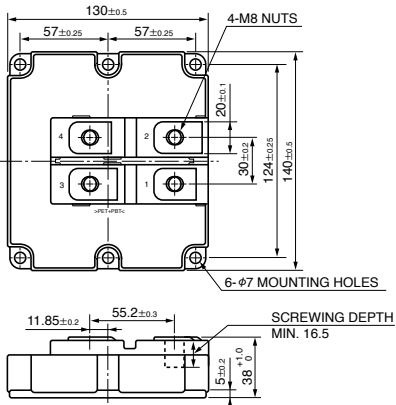

23 RM1800HE-34S
RM1200HE-66S
RM600HE-90S
RM1500HE-66F

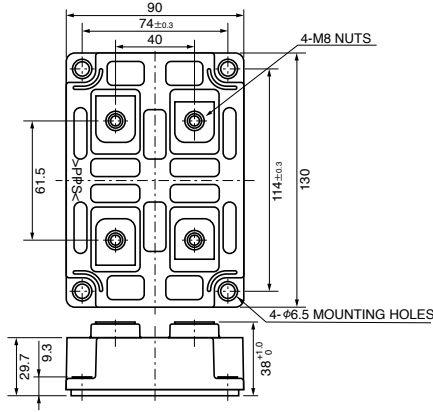

24 RM400/1200DG-66S
RM300DG-90S
RM200/600DG-130S
RM400/800/1200DG-90F
RM250DG-130F
RM600/900/1200DG-66X
RM450/900/1500DG-90X
RM300/450/600DG-130X
RM1000DG-130XA

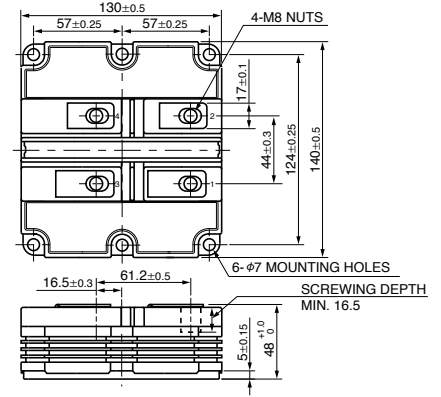

25 RM400,600DY-66S

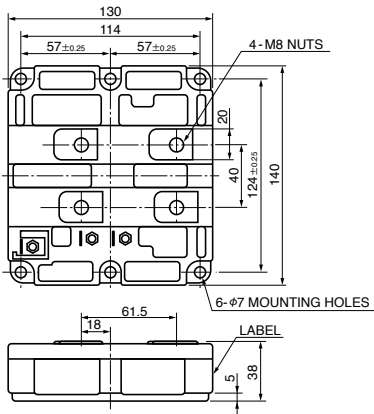

26 RM1000,1500DC-66F
RM600DC-66X
RM1200DC-66X
RM1500DC-90X

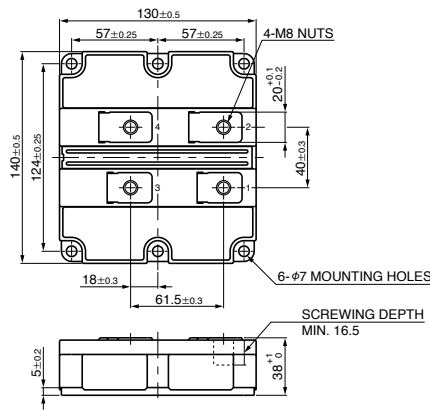

27 RM1200DB-66S
RM900DB/HC-90S

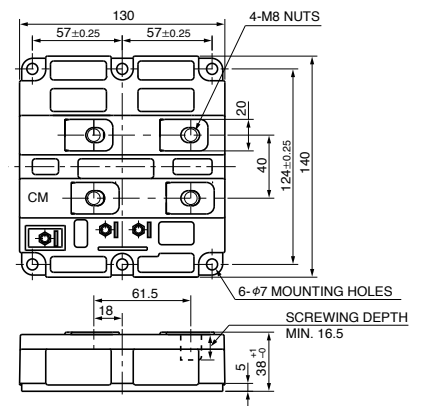

Line-up of MOSFET Modules

Series Matrix of MOSFET Modules

RoHS directive (2011/65/EU, (EU)2015/863) compliant

V _{DS} I _D (A)	75V	Connection	100V	Connection	150V	Connection
100	FM200TU-07A	T	FM200TU-2A	T	FM200TU-3A	T
200	FM400TU-07A	T	FM400TU-2A	T	FM400TU-3A	T
300	FM600TU-07A	T	FM600TU-2A	T	FM600TU-3A	T
Connection						

Outline Drawing of MOSFET Modules

Unit:mm

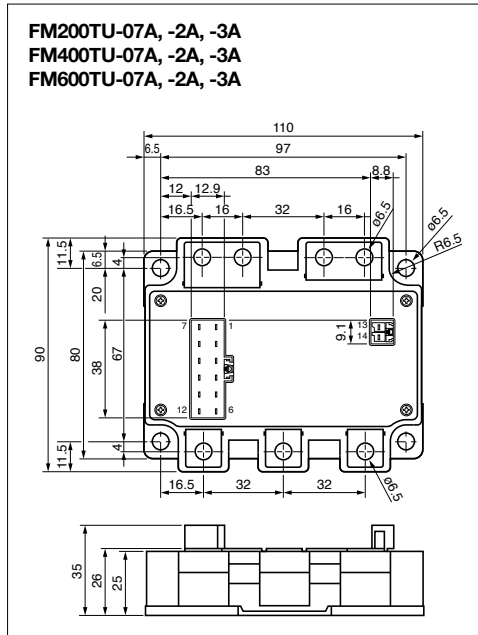

Power Modules for Electric and Hybrid Vehicles



New Products

Package with 6-in-1 connection and integrated water-cooled fin contributes to more compact, high-power inverters for EVs/HEVs

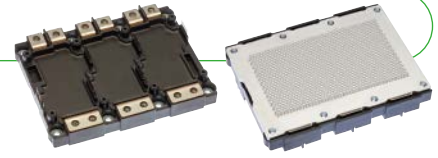

High Power J1 Series Power Modules for EVs/HEVs CT1000CJ1B060,
CT600CJ1B120

<Main Features>

- Integrated direct water-cooling structure with cooling fins and 6-in-1 connection contribute to more compact inverters for EVs/HEVs
- Direct lead bonding (DLB) structure ensures high reliability
- Loss further reduced by incorporating 7th-generation IGBT built with a CSTBT™* structure
- Completely lead-free, conforms to RoHS directives (2011/65/EU)
- Suitable for a variety of electric and hybrid vehicle inverters

*CSTBT™: Mitsubishi Electric's unique IGBT that utilizes the carrier cumulative effect.

Block Diagram

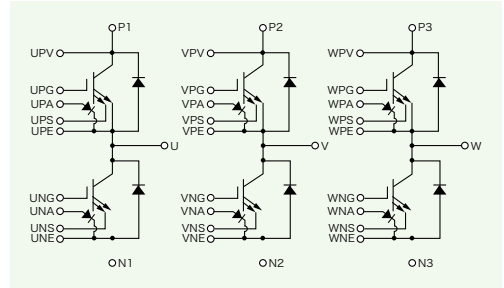

Features

Common

- Long power/temperature cycle life
- High-precision on-chip temperature sensor
- High traceability in managing materials/components for each product throughout the entire production process

- Package structure compliant with the End-of-Life-Vehicles Directive, regulations relating to substances of environmental concern

J Series T-PM (Transfer-molded Power Module)

- Structure incorporates transfer molding and original direct lead bonding(DLB) technique
- DLB structure reduces internal wiring resistance and inductance
- Completely Pb-free (including the pins)

J1 Series (6-in-1)

- Cooling fin integrated direct water-cooled structure and 6-in-1 configuration contribute to minimize the automobile inverter
- DLB structure realizes high reliability
- Installation of the 7th generation IGBT adapting the CSTBT™* structure realizes a further reduction in loss
- On-chip current sensor that enables high-speed current-cutoff protection is installed

Matrix of 650V Power Modules (No. : Number of outline drawing, please refer to page 30)

V _{CEs} (V)	650V						
	Series	J1 Series			J Series		
		Power Module with pin fin	Connection	No.	T-PM	Connection	No.
300	-	-	-	CT300DJG060**	D	02	
600	CT600CJ1A060	C	01	-	-	-	
700	CT700CJ1A060	C	01	-	-	-	
1000	CT1000CJ1B060	C	03	-	-	-	

Connection

D

★★: Under Development

Matrix of 1200V Power Modules

(No. : Number of Outline Drawing, please refer to page 30)

V _{CEs} (V)	1200V			
	Series	J1 Series		
		Power Module with pin fin	Connection	No.
300	CT300CJ1A120**	C	01	
600	CT600CJ1B120	C	03	

Connection

★★: Under Development

Type Name Definition of Power Modules for Electric and Hybrid Vehicles

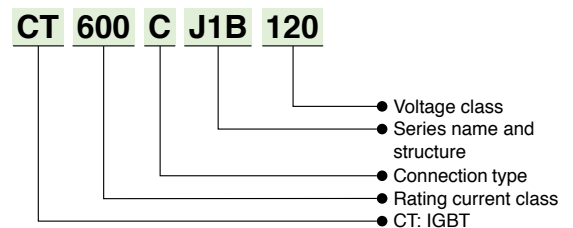

NOTE: In case of CT1000CJ1B060 and CT600CJ1B120, each pair of arms is not connected internally.

Mitsubishi Electric Semiconductors & Devices Website

www.MitsubishiElectric.com/semiconductors/



Keep safety first in your circuit designs!

- Mitsubishi Electric Corporation puts the maximum effort into making semiconductor products better and more reliable, but there is always the possibility that trouble may occur with them. Trouble with semiconductors may lead to personal injury, fire or property damage. Remember to give due consideration to safety when making your circuit designs, with appropriate measures such as (i) placement of substitutive, auxiliary circuits, (ii) use of non-flammable material or (iii) prevention against any malfunction or mishap.

Notes regarding these materials

- These materials are intended as a reference to assist our customers in the selection of the Mitsubishi semiconductor product best suited to the customer's application; they do not convey any license under any intellectual property rights, or any other rights, belonging to Mitsubishi Electric Corporation or a third party.
- Mitsubishi Electric Corporation assumes no responsibility for any damage, or infringement of any third-party's rights, originating in the use of any product data, diagrams, charts, programs, algorithms, or circuit application examples contained in these materials.
- All information contained in these materials, including product data, diagrams, charts, programs and algorithms represents information on products at the time of publication of these materials, and are subject to change by Mitsubishi Electric Corporation without notice due to product improvements or other reasons. It is therefore recommended that customers contact Mitsubishi Electric Corporation or an authorized Mitsubishi Semiconductor product distributor for the latest product information before purchasing a product listed herein. The information described here may contain technical inaccuracies or typographical errors. Mitsubishi Electric Corporation assumes no responsibility for any damage, liability, or other loss rising from these inaccuracies or errors. Please also pay attention to information published by Mitsubishi Electric Corporation by various means, including the Mitsubishi Semiconductor home page (<http://www.MitsubishiElectric.com/>).
- When using any or all of the information contained in these materials, including product data, diagrams, charts, programs, and algorithms, please be sure to evaluate all information as a total system before making a final decision on the applicability of the information and products. Mitsubishi Electric Corporation assumes no responsibility for any damage, liability or other loss resulting from the information contained herein.
- Mitsubishi Electric Corporation semiconductors are not designed or manufactured for use in a device or system that is used under circumstances in which human life is potentially at stake. Please contact Mitsubishi Electric Corporation or an authorized Mitsubishi Semiconductor product distributor when considering the use of a product contained herein for any specific purposes, such as apparatus or systems for transportation, vehicular, medical, aerospace, nuclear, or undersea repeater use.
- The prior written approval of Mitsubishi Electric Corporation is necessary to reprint or reproduce in whole or in part these materials.
- If these products or technologies are subject to the Japanese export control restrictions, they must be exported under a license from the Japanese government and cannot be imported into a country other than the approved destination. Any diversion or reexport contrary to the export control laws and regulations of Japan and/or the country of destination is prohibited.
- Please contact Mitsubishi Electric Corporation or an authorized Mitsubishi Semiconductor product distributor for further details on these materials or the products contained therein.



for a greener tomorrow

Eco Changes is the Mitsubishi Electric Group's environmental statement, and expresses the Group's stance on environmental management. Through a wide range of businesses, we are helping contribute to the realization of a sustainable society.



MITSUBISHI ELECTRIC CORPORATION

HEAD OFFICE: TOKYO BLDG., 2-7-3, MARUNOUCHI, CHIYODA-KU, TOKYO 100-8310, JAPAN
www.MitsubishiElectric.com

Looking for pricing, stock, or lifecycle information?

Click below to explore more details on WIN SOURCE:

- ⊖ [View CM450DY-24S on WIN SOURCE](#)
- ⊖ [Mitsubishi Information](#)

Optimize Your Supply Chain with WIN SOURCE Solutions

- ✓ Global Sourcing Solution
- ✓ Obsolete Management
- ✓ Cost Control Management
- ✓ Shortage Management
- ✓ Alternative Solution
- ✓ Excess Inventory Management