



**THE DATASHEET OF**  
**5962-8866205XA**



**Features**

- ◆ **High-speed address/chip select time**
  - Commercial: 20/25/35ns (max.)
  - Industrial: 20/25/35ns (max.)
  - Military: 25/35/45/55/70/85/100ns (max.)
- ◆ **Low-power operation**
- ◆ **Battery Backup operation – 2V data retention**
- ◆ **Produced with advanced high-performance CMOS technology**
- ◆ **Input and output directly TTL-compatible**
- ◆ **Available in standard 28-pin (300 or 600 mil) ceramic DIP, 28-pin (300 mil) SOJ**
- ◆ **Military product compliant to MIL-STD-883, Class B**
- ◆ **Industrial temperature range (–40°C to +85°C) is available for selected speeds**
- ◆ **Green parts available, see ordering information**

**Description**

The IDT71256 is a 262,144-bit high-speed static RAM organized as 32K x 8. It is fabricated using high-performance, high-reliability CMOS technology.

Address access times as fast as 20ns are available with power consumption of only 350mW (typ.). The circuit also offers a reduced power standby mode. When  $\overline{CS}$  goes HIGH, the circuit will automatically go to and remain in, a low-power standby mode as long as  $\overline{CS}$  remains HIGH. This capability provides significant system level power and cooling savings. The low-power (L) version also offers a battery backup data retention capability where the circuit typically consumes only 5 $\mu$ W when operating off a 2V battery.

The IDT71256 is packaged in a 28-pin (300 or 600 mil) ceramic DIP, a 28-pin 300 mil SOJ providing high board level packing densities.

The IDT71256 military RAM is manufactured in compliance with the latest revision of MIL-STD-883, Class B, making it ideally suited to military temperature applications demanding the highest level of performance and reliability.

**Functional Block Diagram**

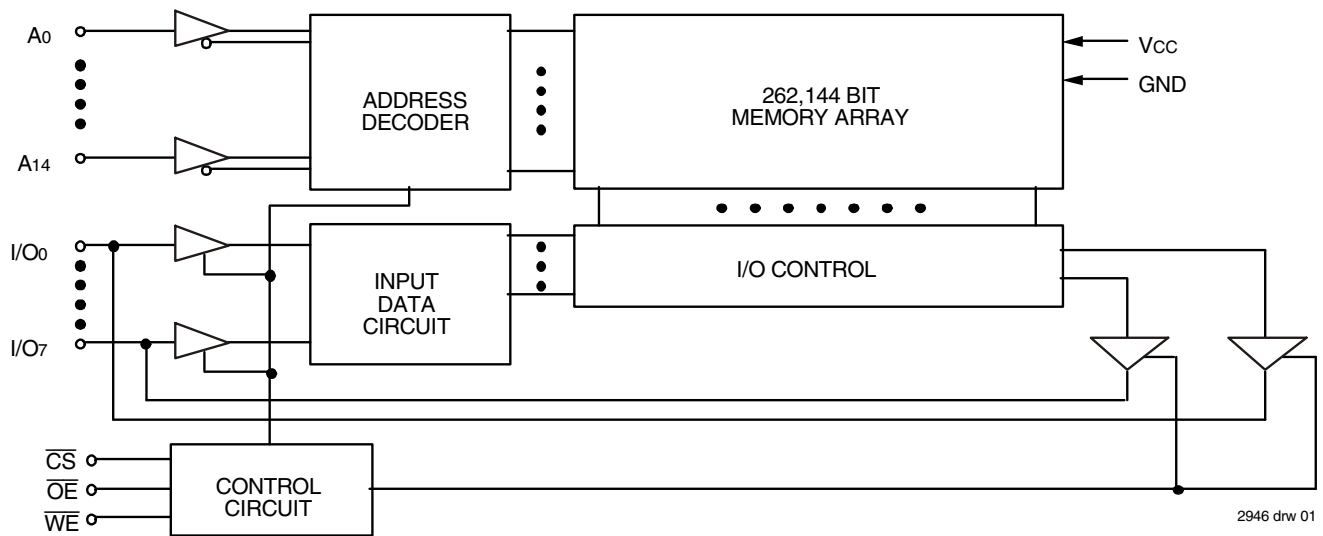

2946 drw 01

## Pin Configurations<sup>(1)</sup>

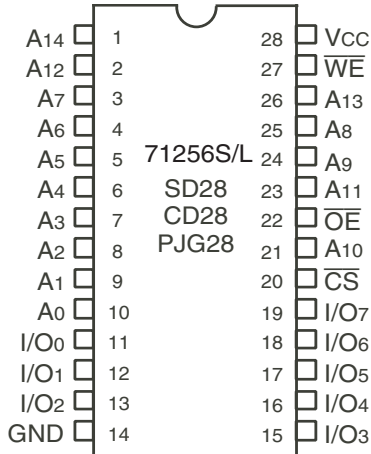

2946 drw 02

### DIP/SOJ Top View

**NOTE:**

1. This text does not indicate orientation of actual part-marking.

## Pin Descriptions

Name	Description
A <sub>0</sub> - A <sub>14</sub>	Address Inputs
I/O <sub>0</sub> - I/O <sub>7</sub>	Data Input/Output
$\overline{CS}$	Chip Select
$\overline{WE}$	Write Enable
$\overline{OE}$	Output Enable
GND	Ground
V <sub>CC</sub>	Power

2946 tbl 01

## Truth Table<sup>(1)</sup>

$\overline{WE}$	$\overline{CS}$	$\overline{OE}$	I/O	Function
X	H	X	High-Z	Standby (ISB)
X	V <sub>HC</sub>	X	High-Z	Standby (ISB1)
H	L	H	High-Z	Output Disabled
H	L	L	DOUT	Read Data
L	L	X	DIN	Write Data

2946 tbl 02

**NOTE:**

1. H = V<sub>IH</sub>, L = V<sub>IL</sub>, X = Don't care.

## Absolute Maximum Ratings<sup>(1)</sup>

Symbol	Rating	Com'l.	Ind.	Mil.	Unit
V <sub>TERM</sub>	Terminal Voltage with Respect to GND	-0.5 to +7.0	-0.5 to +7.0	-0.5 to +7.0	V
T <sub>A</sub>	Operating Temperature	0 to +70	-40 to +85	-55 to +125	°C
T <sub>BIAS</sub>	Temperature Under Bias	-55 to +125	-55 to +125	-65 to +135	°C
T <sub>STG</sub>	Storage Temperature	-55 to +125	-55 to +125	-65 to +150	°C
P <sub>T</sub>	Power Dissipation	1.0	1.0	1.0	W
I <sub>OUT</sub>	DC Output Current	50	50	50	mA

2946 tbl 03

**NOTE:**

1. Stresses greater than those listed under ABSOLUTE MAXIMUM RATINGS may cause permanent damage to the device. This is a stress rating only and functional operation of the device at these or any other conditions above those indicated in the operational sections of this specification is not implied. Exposure to absolute maximum rating conditions for extended periods may affect reliability.

## Capacitance (T<sub>A</sub> = +25°C, f = 1.0MHz)

Symbol	Parameter <sup>(1)</sup>	Conditions	Max.	Unit
C <sub>IN</sub>	Input Capacitance	V <sub>IN</sub> = 0V	11	pF
C <sub>I/O</sub>	I/O Capacitance	V <sub>OUT</sub> = 0V	11	pF

2946 tbl 04

**NOTE:**

1. This parameter is determined by device characterization, but is not production tested.

### Recommended Operating Temperature and Supply Voltage

Grade	Temperature	GND	Vcc
Military	-55°C to +125°C	0V	5V ± 10%
Industrial	-40°C to +85°C	0V	5V ± 10%
Commercial	0°C to +70°C	0V	5V ± 10%

2946 tbl 05

### Recommended DC Operating Conditions

Symbol	Parameter	Min.	Typ.	Max.	Unit
Vcc	Supply Voltage	4.5	5.0	5.5	V
GND	Ground	0	0	0	V
V <sub>IH</sub>	Input High Voltage	2.2	—	6.0	V
V <sub>IL</sub>	Input Low Voltage	-0.5 <sup>(1)</sup>	—	0.8	V

2946 tbl 06

**NOTE:**

- V<sub>IL</sub> (min.) = -3.0V for pulse width less than 20ns, once per cycle.

### DC Electrical Characteristics<sup>(1,2)</sup> (Vcc = 5.0V ± 10%, V<sub>Lc</sub> = 0.2V, V<sub>Hc</sub> = Vcc - 0.2V)

Symbol	Parameter	Power	71256S/L20	71256S/L25	71256S/L35	71256S/L45	Unit		
			Com'l. & Ind	Com'l. & Ind	Mil.	Com'l. & Ind		Mil.	Mil.
ICC	Dynamic Operating Current CS ≤ V <sub>IL</sub> , Outputs Open Vcc = Max., f <sub>MAX</sub> <sup>(2)</sup>	S	—	—	150	—	140	135	mA
		L	135	125	130	115	120	115	
ISB	Standby Power Supply Current (TTL Level), CS ≥ V <sub>IH</sub> , Vcc = Max., Outputs Open, f = f <sub>MAX</sub> <sup>(2)</sup>	S	—	—	20	—	20	20	mA
		L	3	3	3	3	3	3	
ISB1	Full Standby Power Supply Current (CMOS Level), CS ≥ V <sub>Hc</sub> , Vcc = Max., f = 0	S	—	—	20	—	20	20	mA
		L	0.6	0.6	1.5	0.6	1.5	1.5	

2946 tbl 07

Symbol	Parameter	Power	71256S/L55	71256S/L70	71256S/L85	71256S/L100	Unit
			Mil.	Mil.	Mil.	Mil.	
ICC	Dynamic Operating Current CS ≤ V <sub>IL</sub> , Outputs Open Vcc = Max., f <sub>MAX</sub> <sup>(2)</sup>	S	135	135	135	135	mA
		L	115	115	115	115	
ISB	Standby Power Supply Current (TTL Level), CS ≥ V <sub>IH</sub> , Vcc = Max., Outputs Open, f = f <sub>MAX</sub> <sup>(2)</sup>	S	20	20	20	20	mA
		L	3	3	3	3	
ISB1	Full Standby Power Supply Current (CMOS Level), CS ≥ V <sub>Hc</sub> , Vcc = Max., f = 0	S	20	20	20	20	mA
		L	1.5	1.5	1.5	1.5	

2946 tbl 08

**NOTES:**

- All values are maximum guaranteed values.
- f<sub>MAX</sub> = 1/TRC, all address inputs are cycling at f<sub>MAX</sub>; f = 0 means no address pins are cycling.

## AC Test Conditions

Input Pulse Levels	GND to 3.0V
Input Rise/Fall Times	5ns
Input Timing Reference Levels	1.5V
Output Reference Levels	1.5V
AC Test Load	See Figures 1 and 2

2946 tbl 09

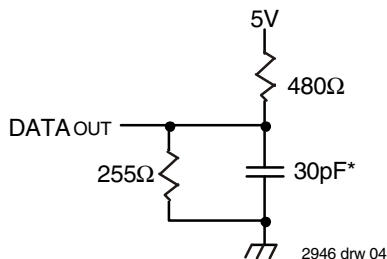

Figure 1. AC Test Load

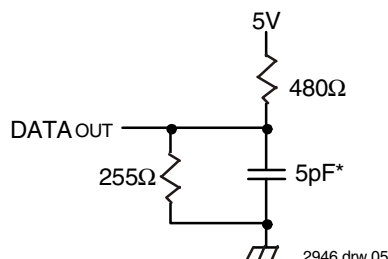

Figure 2. AC Test Load  
(for tCLZ, tOLZ, tCHZ, tOHZ, tOW, and tWHZ)

\*Includes scope and jig capacitances

## DC Electrical Characteristics (V<sub>CC</sub> = 5.0V ± 10%)

Symbol	Parameter	Test Conditions	IDT71256S			IDT71256L			Unit	
			Min.	Typ.	Max.	Min.	Typ.	Max.		
I <sub>LI</sub>	Input Leakage Current	V <sub>CC</sub> = Max., V <sub>IN</sub> = GND to V <sub>CC</sub>	MIL. COM"L & IND.	—	—	10 5	—	—	5 2	μA
I <sub>LO</sub>	Output Leakage Current	V <sub>CC</sub> = Max., $\overline{CS}$ = V <sub>H</sub> , V <sub>OUT</sub> = GND to V <sub>CC</sub>	MIL. COM"L & IND.	—	—	10 5	—	—	5 2	μA
V <sub>OL</sub>	Output Low Voltage	I <sub>OL</sub> = 8mA, V <sub>CC</sub> = Min.	—	—	0.4	—	—	0.4	V	
		I <sub>OL</sub> = 10mA, V <sub>CC</sub> = Min.	—	—	0.5	—	—	0.5		
V <sub>OH</sub>	Output High Voltage	I <sub>OH</sub> = -4mA, V <sub>CC</sub> = Min.	2.4	—	—	2.4	—	—	V	

2946 tbl 10

## Data Retention Characteristics Over All Temperature Ranges (L Version Only) (V<sub>LC</sub> = 0.2V, V<sub>HC</sub> = V<sub>CC</sub> - 0.2V)

Symbol	Parameter	Test Condition	Min.	Typ. <sup>(1)</sup> V <sub>CC</sub> @		Max. V <sub>CC</sub> @		Unit
				2.0V	3.0V	2.0V	3.0V	
V <sub>DR</sub>	V <sub>CC</sub> for Data Retention	—	2.0	—	—	—	—	V
I <sub>CDR</sub>	Data Retention Current	MIL. COM"L & IND.	—	—	—	500 120	800 200	μA
t <sub>CDR</sub>	Chip Deselect to Data Retention Time	$\overline{CS} \geq V_{HC}$	0	—	—	—	—	ns
t <sub>R</sub> <sup>(2)</sup>	Operation Recovery Time		t <sub>RC</sub> <sup>(2)</sup>	—	—	—	—	ns

2946 tbl 11

### NOTES:

1. T<sub>A</sub> = +25°C.
2. t<sub>RC</sub> = Read Cycle Time.
3. This parameter is guaranteed by device characterization, but is not production tested.

## Low Vcc Data Retention Waveform

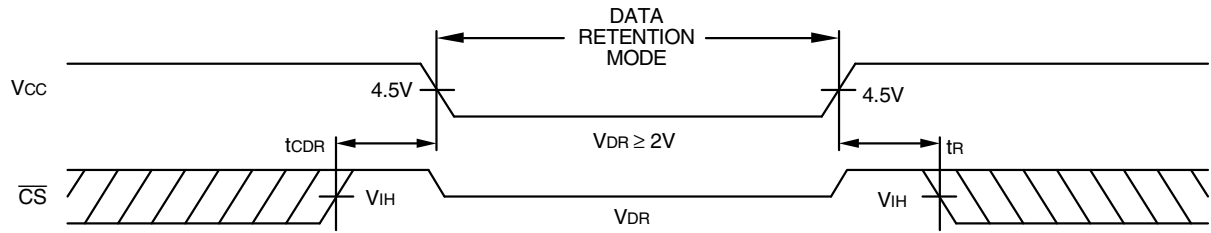

2946 drw 06

## AC Electrical Characteristics (Vcc = 5.0V ± 10%, All Temperature Ranges)

Symbol	Parameter	71256L20 <sup>(1)</sup>		71256S25 71256L25		71256S35 71256L35		71256S45 <sup>(3)</sup> 71256L45 <sup>(3)</sup>		Unit
		Min.	Max.	Min.	Max.	Min.	Max.	Min.	Max.	
<b>Read Cycle</b>										
t <sub>RC</sub>	Read Cycle Time	20	—	25	—	35	—	45	—	ns
t <sub>AA</sub>	Address Access Time	—	20	—	25	—	35	—	45	ns
t <sub>ACS</sub>	Chip Select Access Time	—	20	—	25	—	35	—	45	ns
t <sub>OLZ</sub> <sup>(2)</sup>	Chip Select to Output in Low-Z	5	—	5	—	5	—	5	—	ns
t <sub>CHZ</sub> <sup>(2)</sup>	Chip Deselect to Output in High-Z	—	10	—	11	—	15	—	20	ns
t <sub>OE</sub>	Output Enable to Output Valid	—	10	—	11	—	15	—	20	ns
t <sub>OLZ</sub> <sup>(2)</sup>	Output Enable to Output in Low-Z	2	—	2	—	2	—	0	—	ns
t <sub>OHZ</sub> <sup>(2)</sup>	Output Disable to Output in High-Z	2	8	2	10	2	15	—	20	ns
t <sub>OH</sub>	Output Hold from Address Change	5	—	5	—	5	—	5	—	ns
<b>Write Cycle</b>										
t <sub>WC</sub>	Write Cycle Time	20	—	25	—	35	—	45	—	ns
t <sub>CW</sub>	Chip Select to End-of-Write	15	—	20	—	30	—	40	—	ns
t <sub>AW</sub>	Address Valid to End-of-Write	15	—	20	—	30	—	40	—	ns
t <sub>AS</sub>	Address Set-up Time	0	—	0	—	0	—	0	—	ns
t <sub>WP</sub>	Write Pulse Width	15	—	20	—	30	—	35	—	ns
t <sub>WR</sub>	Write Recovery Time	0	—	0	—	0	—	0	—	ns
t <sub>DW</sub>	Data to Write Time Overlap	11	—	13	—	15	—	20	—	ns
t <sub>WHZ</sub> <sup>(2)</sup>	Write Enable to Output in High-Z	—	10	—	11	—	15	—	20	ns
t <sub>DH</sub>	Data Hold from Write Time	0	—	0	—	0	—	0	—	ns
t <sub>OW</sub> <sup>(2)</sup>	Output Active from End-of-Write	5	—	5	—	5	—	5	—	ns

2946 tbl 12

**NOTES:**

- 0° to +70°C or -40° to +85°C temperature range only.
- This parameter is guaranteed by device characterization, but is not production tested.
- 55°C to +125°C temperature range only.

**AC Electrical Characteristics (Vcc = 5.0V ± 10%, Military Temperature Ranges)**

Symbol	Parameter	71256S55 <sup>(1)</sup> 71256L55 <sup>(1)</sup>		71256S70 <sup>(1)</sup> 71256L70 <sup>(1)</sup>		71256S85 <sup>(1)</sup> 71256L85 <sup>(1)</sup>		71256S100 <sup>(1)</sup> 71256L100 <sup>(1)</sup>		Unit
		Min.	Max.	Min.	Max.	Min.	Max.	Min.	Max.	
<b>Read Cycle</b>										
t <sub>RC</sub>	Read Cycle Time	55	—	70	—	85	—	100	—	ns
t <sub>AA</sub>	Address Access Time	—	55	—	70	—	85	—	100	ns
t <sub>ACS</sub>	Chip Select Access Time	—	55	—	70	—	85	—	100	ns
t <sub>OLZ</sub> <sup>(2)</sup>	Chip Select to Output in Low-Z	5	—	5	—	5	—	5	—	ns
t <sub>CHZ</sub> <sup>(2)</sup>	Chip Deselect to Output in High-Z	—	25	—	30	—	35	—	40	ns
t <sub>OE</sub>	Output Enable to Output Valid	—	25	—	30	—	35	—	40	ns
t <sub>OLZ</sub> <sup>(2)</sup>	Output Enable to Output in Low-Z	0	—	0	—	0	—	0	—	ns
t <sub>OHZ</sub> <sup>(2)</sup>	Output Disable to Output in High-Z	0	25	0	30	—	35	—	40	ns
t <sub>OH</sub>	Output Hold from Address Change	5	—	5	—	5	—	5	—	ns
<b>Write Cycle</b>										
t <sub>WC</sub>	Write Cycle Time	55	—	70	—	85	—	100	—	ns
t <sub>CW</sub>	Chip Select to End-of-Write	50	—	60	—	70	—	80	—	ns
t <sub>AW</sub>	Address Valid to End-of-Write	50	—	60	—	70	—	80	—	ns
t <sub>AS</sub>	Address Set-up Time	0	—	0	—	0	—	0	—	ns
t <sub>WP</sub>	Write Pulse Width	40	—	45	—	50	—	55	—	ns
t <sub>WR</sub>	Write Recovery Time	0	—	0	—	0	—	0	—	ns
t <sub>DW</sub>	Data to Write Time Overlap	25	—	30	—	35	—	40	—	ns
t <sub>WHZ</sub> <sup>(2)</sup>	Write Enable to Output in High-Z	—	25	—	30	—	35	—	40	ns
t <sub>DH</sub>	Data Hold from Write Time ( $\overline{WE}$ )	0	—	0	—	0	—	0	—	ns
t <sub>OW</sub> <sup>(2)</sup>	Output Active from End-of-Write	5	—	5	—	5	—	5	—	ns

2946 tbl 13

**NOTES:**

- 55° to +125°C temperature range only.
- This parameter is guaranteed by device characterization, but is not production tested.

### Timing Waveform of Read Cycle No. 1<sup>(1)</sup>

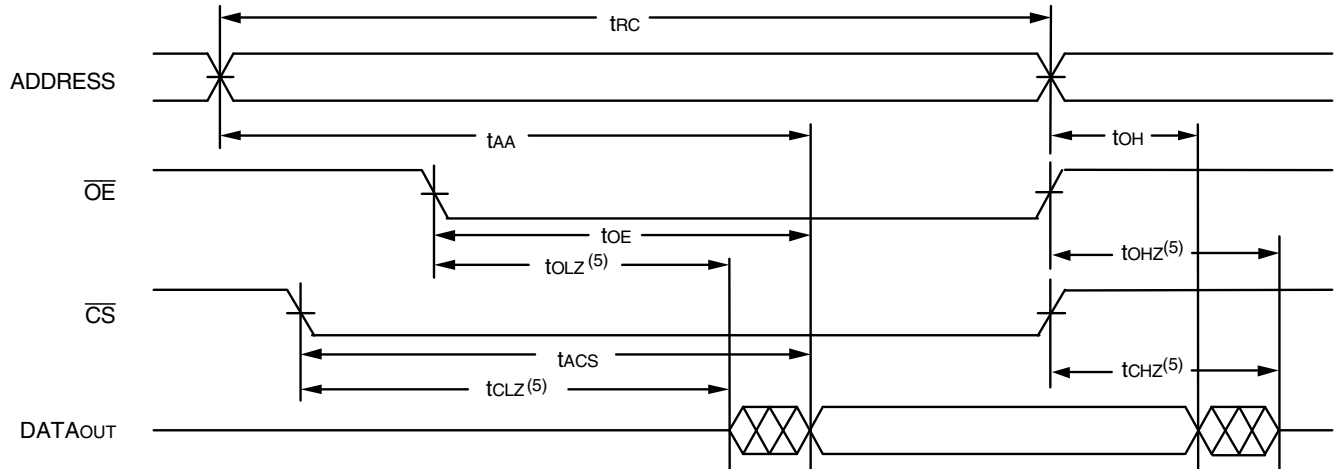

2946 drw 07

### Timing Waveform of Read Cycle No. 2<sup>(1,2,4)</sup>

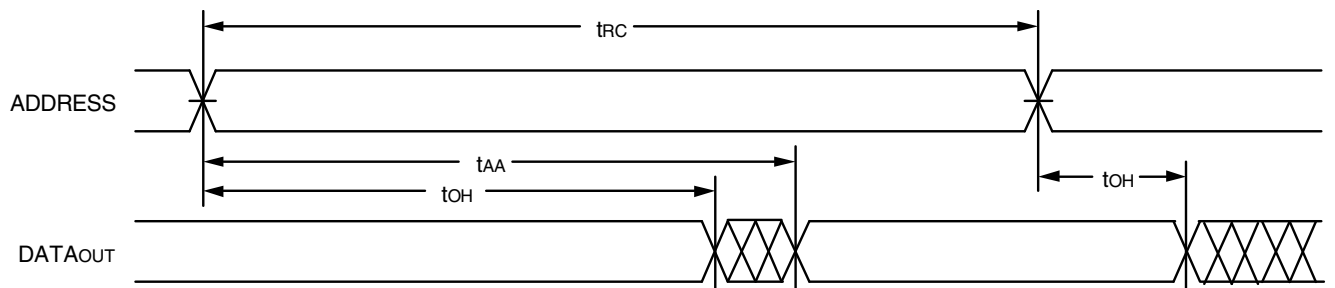

2946 drw 08

### Timing Waveform of Read Cycle No. 2<sup>(1,3,4)</sup>

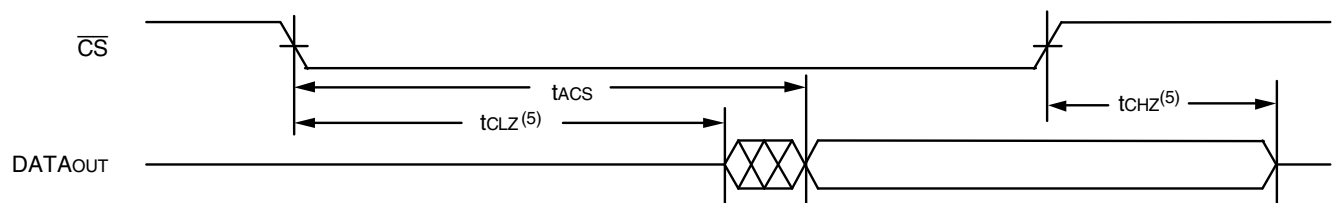

2946 drw 09

**NOTES:**

1.  $\overline{WE}$  is HIGH for Read Cycle.
2. Device is continuously selected,  $\overline{CS}$  is LOW.
3. Address valid prior to or coincident with  $\overline{CS}$  transition LOW.
4.  $\overline{OE}$  is LOW.
5. Transition is measured  $\pm 200\text{mV}$  from steady state.

### Timing Waveform of Write Cycle No. 1 ( $\overline{WE}$ Controlled Timing)<sup>(1,2,4,6)</sup>

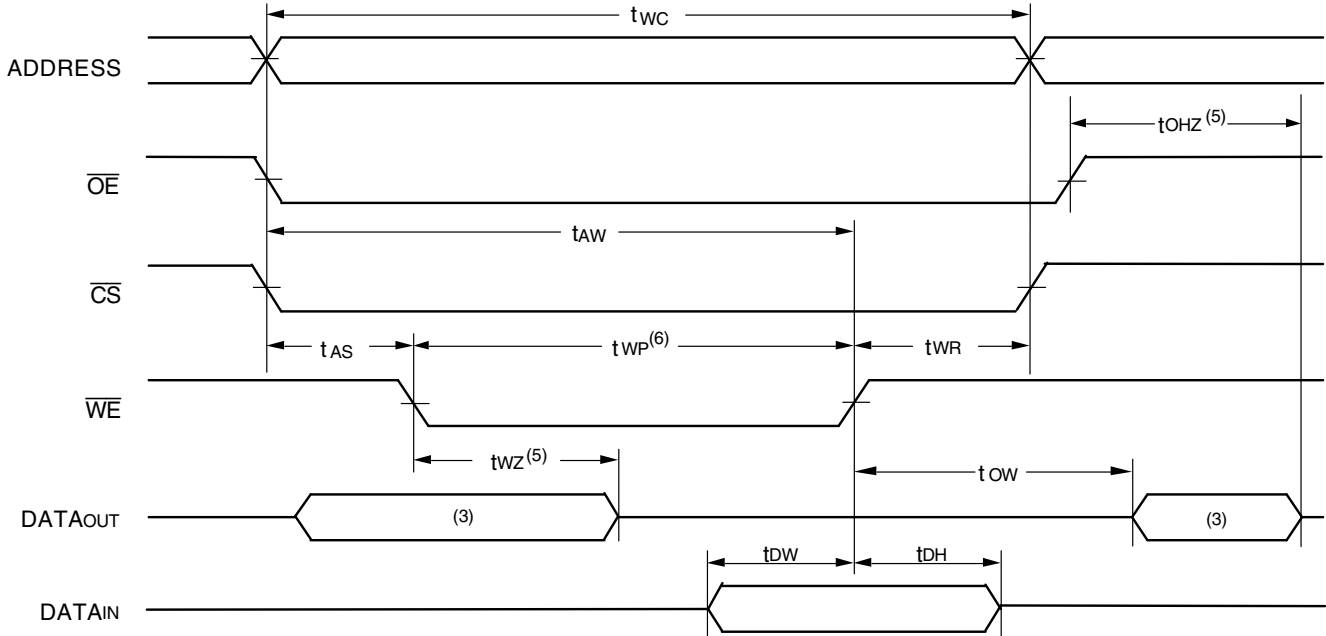

2946 drw 10

### Timing Waveform of Write Cycle No. 2 ( $\overline{CS}$ Controlled Timing)<sup>(1,2,4)</sup>

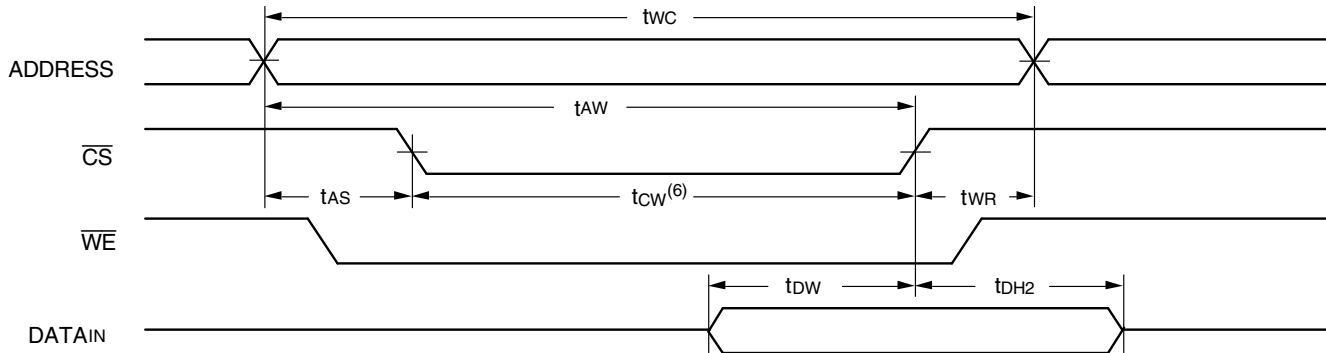

2946 drw 11

**NOTES:**

1. A write occurs during the overlap of a LOW  $\overline{CS}$  and a LOW  $\overline{WE}$ .
2.  $t_{WR}$  is measured from the earlier of  $\overline{CS}$  or  $\overline{WE}$  going HIGH to the end of the write cycle.
3. During this period, I/O pins are in the output state so that the input signals must not be applied.
4. If the  $\overline{CS}$  LOW transition occurs simultaneously with or after the  $\overline{WE}$  LOW transition, the outputs remain in a high-impedance state.
5. Transition is measured  $\pm 200\text{mV}$  from steady state.
6. If  $\overline{OE}$  is LOW during a  $\overline{WE}$  controlled write cycle, the write pulse width must be the larger of  $t_{WP}$  or  $(t_{WHZ} + t_{DW})$  to allow the I/O drivers to turn off and data to be placed on the bus for the required  $t_{DW}$ . If  $\overline{OE}$  is HIGH during a  $\overline{WE}$  controlled write cycle, this requirement does not apply and the minimum write pulse width can be as short as the specified  $t_{WP}$ . For a  $\overline{CS}$  controlled write cycle,  $\overline{OE}$  may be LOW with no degradation to  $t_{CW}$ .

### Ordering Information — Commercial & Industrial

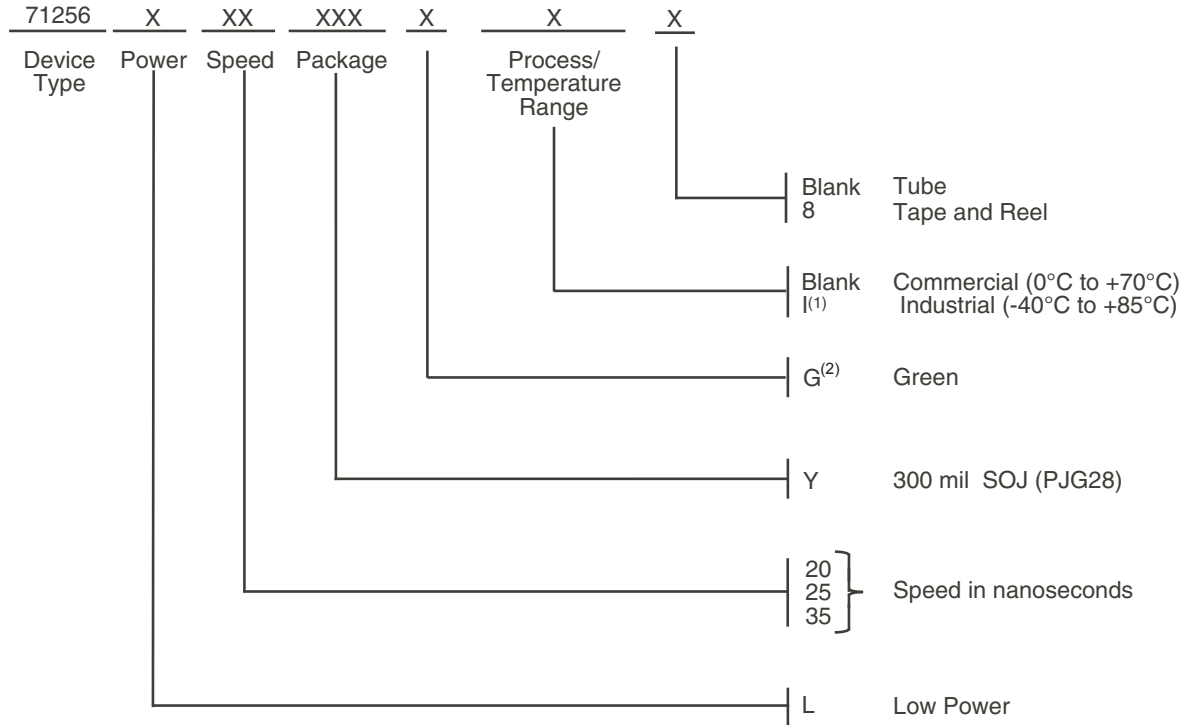

2946 drw 13

**NOTES:**

1. Contact your local sales office for Industrial temp range for other speeds, packages and powers.
2. Green parts available. For specific speeds, packages and powers contact your local sales office.

### Ordering Information — Military

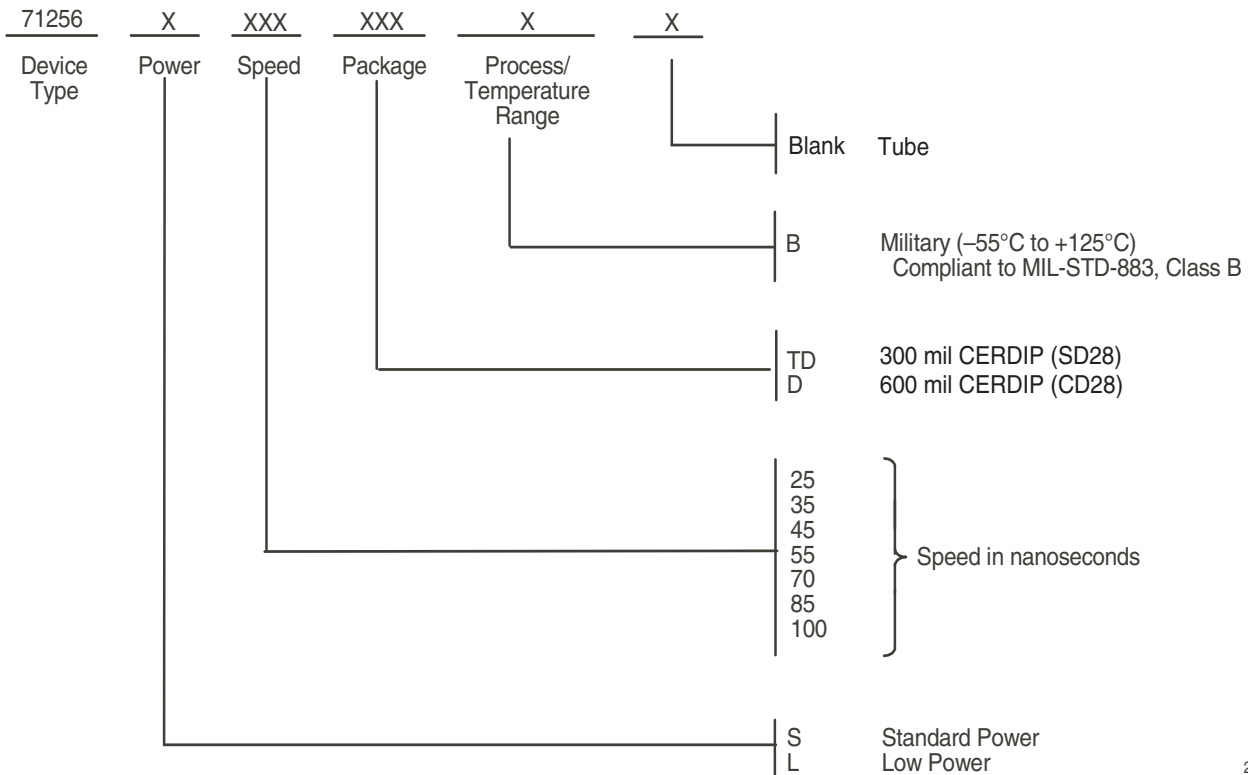

2946 drw 12

## Orderable Part Information

Speed (ns)	Orderable Part ID	Pkg. Code	Pkg. Type	Temp. Grade
20	71256L20YG	PJG28	SOJ	C
	71256L20YG8	PJG28	SOJ	C
	71256L20YGI	PJG28	SOJ	I
	71256L20YGI8	PJG28	SOJ	I
25	71256L25DB	CD28	CDIP	M
	71256L25TDB	SD28	CDIP	M
	71256L25YG	PJG28	SOJ	C
	71256L25YG8	PJG28	SOJ	C
	71256L25YGI	PJG28	SOJ	I
	71256L25YGI8	PJG28	SOJ	I
35	71256L35DB	CD28	CDIP	M
	71256L35TDB	SD28	CDIP	M
	71256L35YG	PJG28	SOJ	C
	71256L35YG8	PJG28	SOJ	C
	71256L35YGI	PJG28	SOJ	I
	71256L35YGI8	PJG28	SOJ	I
45	71256L45DB	CD28	CDIP	M
	71256L45TDB	SD28	CDIP	M
55	71256L55DB	CD28	CDIP	M
	71256L55TDB	SD28	CDIP	M
70	71256L70DB	CD28	CDIP	M
	71256L70TDB	SD28	CDIP	M
85	71256L85DB	CD28	CDIP	M
	71256L85TDB	SD28	CDIP	M
100	71256L100DB	CD28	CDIP	M
	71256L100TDB	SD28	CDIP	M

Speed (ns)	Orderable Part ID	Pkg. Code	Pkg. Type	Temp. Grade
25	71256S25DB	CD28	CDIP	M
	71256S25TDB	SD28	CDIP	M
35	71256S35DB	CD28	CDIP	M
	71256S35TDB	SD28	CDIP	M
45	71256S45DB	CD28	CDIP	M
	71256S45TDB	SD28	CDIP	M
55	71256S55DB	CD28	CDIP	M
	71256S55TDB	SD28	CDIP	M
70	71256S70DB	CD28	CDIP	M
	71256S70TDB	SD28	CDIP	M
85	71256S85DB	CD28	CDIP	M
	71256S85TDB	SD28	CDIP	M
100	71256S100DB	CD28	CDIP	M
	71256S100TDB	SD28	CDIP	M

## Datasheet Document History

11/4/99:		Updated to new format
	Pg. 1–5, 9	Added Industrial Temperature Range offerings
	Pg. 1	Removed 30, 120, and 150ns military and 45ns commercial speed grade offerings.
	Pg. 2	Removed P28-2 package from DIP/SOJ Top View
	Pg. 3	Removed 30ns and 45ns (Commercial only) speed grade offerings from DC Electrical table
		Revised notes and footnotes
	Pg. 5	Removed 30ns speed grade offering from AC Electrical table
		Revised notes and footnotes
	Pg. 6	Expressed Military Temperature range on AC Electrical table
		Revised notes and footnotes
	Pg. 8	Removed Note 1 and renumbered notes and footnotes
	Pg. 9	Revised Ordering Information and presented by temperature range offering
	Pg. 10	Added Datasheet Document History
08/09/00:		Not recommended for new designs
02/01/01:		Remove "Not recommended for new designs"
11/15/06:	Pg. 3	Changed power limits for commercial and industrial. Refer to PCNSR-0602-03. Added Restricted hazardous substance device to ordering information.
11/01/08:	Pg. 2,9	Corrected typo on pin 21 in 32-Pin LCC diagram. Updated the ordering information by removing the "IDT" notation.
04/28/11:	Pg. 1, 2, 5, 9	Added 20ns to Industrial offering. Obsoleted 28-pin 600 mil, 32-pin LCC and Added Tape and Reel to Ordering information and updated description of Restricted hazardous substance device to Green.
09/26/13:	Pg. 1	In the Description: removed IDT's reference to fabrication and removed the sentence "In the full standby mode, the low-power device consumes less than 15 $\mu$ W, typically".
08/06/20:	Pg. 1 - 12	Rebranded as Renesas datasheet
	Pg.1 & 9	Updated Industrial temp and green availability
	Pg. 2 & 9	Updated package codes
	Pg. 10	Added Orderable Part Information tables

## IMPORTANT NOTICE AND DISCLAIMER

RENESAS ELECTRONICS CORPORATION AND ITS SUBSIDIARIES (“RENESAS”) PROVIDES TECHNICAL SPECIFICATIONS AND RELIABILITY DATA (INCLUDING DATASHEETS), DESIGN RESOURCES (INCLUDING REFERENCE DESIGNS), APPLICATION OR OTHER DESIGN ADVICE, WEB TOOLS, SAFETY INFORMATION, AND OTHER RESOURCES “AS IS” AND WITH ALL FAULTS, AND DISCLAIMS ALL WARRANTIES, EXPRESS OR IMPLIED, INCLUDING, WITHOUT LIMITATION, ANY IMPLIED WARRANTIES OF MERCHANTABILITY, FITNESS FOR A PARTICULAR PURPOSE, OR NON-INFRINGEMENT OF THIRD-PARTY INTELLECTUAL PROPERTY RIGHTS.

These resources are intended for developers who are designing with Renesas products. You are solely responsible for (1) selecting the appropriate products for your application, (2) designing, validating, and testing your application, and (3) ensuring your application meets applicable standards, and any other safety, security, or other requirements. These resources are subject to change without notice. Renesas grants you permission to use these resources only to develop an application that uses Renesas products. Other reproduction or use of these resources is strictly prohibited. No license is granted to any other Renesas intellectual property or to any third-party intellectual property. Renesas disclaims responsibility for, and you will fully indemnify Renesas and its representatives against, any claims, damages, costs, losses, or liabilities arising from your use of these resources. Renesas' products are provided only subject to Renesas' Terms and Conditions of Sale or other applicable terms agreed to in writing. No use of any Renesas resources expands or otherwise alters any applicable warranties or warranty disclaimers for these products.

(Disclaimer Rev.1.01)

### Corporate Headquarters

TOYOSU FORESIA, 3-2-24 Toyosu,  
Koto-ku, Tokyo 135-0061, Japan  
[www.renesas.com](http://www.renesas.com)

### Trademarks



Renesas and the Renesas logo are trademarks of Renesas Electronics Corporation. All trademarks and registered trademarks are the property of their respective owners.

### Contact Information

For further information on a product, technology, the most up-to-date version of a document, or your nearest sales office, please visit [www.renesas.com/contact-us/](http://www.renesas.com/contact-us/).

## Looking for pricing, stock, or lifecycle information?

Click below to explore more details on WIN SOURCE:

-  [View 5962-8866205XA on WIN SOURCE](#)
-  [Renesas Electronics America](#) Information

## Optimize Your Supply Chain with WIN SOURCE Solutions

-  Global Sourcing Solution
-  Obsolete Management
-  Cost Control Management
-  Shortage Management
-  Alternative Solution
-  Excess Inventory Management