

# PRODUCT SPECIFICATION

<b>Part Number</b>	SIM7050	<b>Rev</b>	A1	<b>Date</b>	18/08/21		
<b>Product Description</b>	Micro SIM Card Connector, Retainer Type, 6 & 8 Pin, SMT, 2.45mm Profile			<b>Page</b>	1		
<b>Doc Number</b>	SIM7050	Prepared	AO	Checked	VJ	Approved	ST

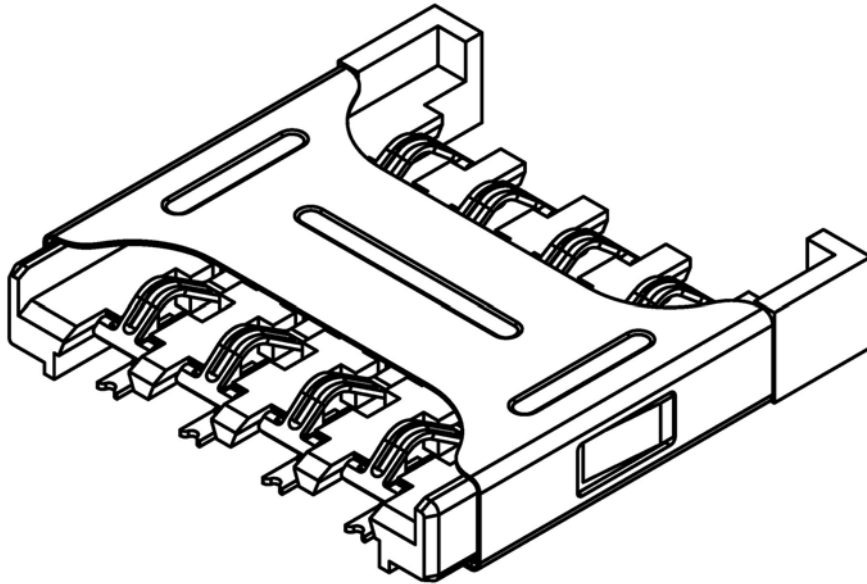

# PRODUCT SPECIFICATION

<b>Part Number</b>	SIM7050	<b>Rev</b>	A1	<b>Date</b>	18/08/21		
<b>Product Description</b>	Micro SIM Card Connector, Retainer Type, 6 & 8 Pin, SMT, 2.45mm Profile			<b>Page</b>	2		
<b>Doc Number</b>	SIM7050	<b>Prepared</b>	<b>AO</b>	<b>Checked</b>	<b>VJ</b>	<b>Approved</b>	<b>ST</b>

## 1.0 SCOPE.

This specification covers performance, tests and quality requirements for the Micro SIM Card Connector SIM7050 (Retainer Type, 6 & 8Pin, SMT, 2.45mm Profile).

## 2.0 PRODUCT NAME AND PART NUMBER.

Micro SIM Card Connector, 6 & 8 Pin, Retainer Type: SIM7050.

## 3.0 PRODUCT SHAPE, DIMENSIONS AND MATERIAL.

Please refer to drawings.

## 4.0 RATINGS.

- Current rating ..... 0.5 Amp Max.
- Voltage rating ..... 30 Volts AC (rms.) Max.
- Operating Temperature Range ..... -40°C to +85°C
- Storage Temperature ..... -40°C to +85°C
- Storage Humidity..... Relative Humidity: 10% ~ 95% R.H.

## 5.0 TEST AND MEASUREMENT CONDITIONS.

Product is designed to meet electrical, mechanical and environmental performance requirements specified in Paragraph 6.0. All tests are performed at ambient environmental conditions unless otherwise specified.

## 6.0 PERFORMANCE.

Item	Test Condition	Requirement
Examination of Product	Visual, dimensional and functional inspection as per quality plan.	Product shall meet requirements of product drawing and specification.

# PRODUCT SPECIFICATION

<b>Part Number</b>	SIM7050	<b>Rev</b>	A1	<b>Date</b>	18/08/21		
<b>Product Description</b>	Micro SIM Card Connector, Retainer Type, 6 & 8 Pin, SMT, 2.45mm Profile			<b>Page</b>	3		
<b>Doc Number</b>	SIM7050	<b>Prepared</b>	<b>AO</b>	<b>Checked</b>	<b>VJ</b>	<b>Approved</b>	<b>ST</b>

## 6.1 Electrical Performance.

Item	Test Condition	Requirement
Contact Resistance	Measure and record contact resistance of mated connector using test current of 10mA max and 20 mV open circuit voltage in accordance with EIA-364-23.	100 mΩ max initial
Insulation Resistance	Measure by applying test potential between the adjacent contacts, and between the contacts and ground in the mated connector. In accordance with EIA-364-21.	1000 MΩ minimum @500V DC
Dielectric Strength	Measure by applying test potential between the adjacent contacts, and between the contacts and ground in the mated connector. In accordance with EIA-364-20.	Connector must withstand test potential of 500-V AC for 1 minute.

## 6.2 Mechanical Performance.

Item	Test Condition	Requirement
Durability	Insert & remove SIM card for 5000cycles. In accordance with EIA-364-09.	Contact Resistance: 100mΩ max.
Vibration	Frequency: 10~100Hz, 0.0132 g <sup>2</sup> /Hz; Frequency: 100~500Hz, -3db/Oct Applied for 1 hour in each 3 mutually perpendicular axes (IEC60068-2-64-Fh)	No electrical discontinuity greater than 1 μsec (s) shall occur. Contact resistance:100mΩ max.
Mechanical Shock	Pulse shape = half sine Peak acceleration = 490m/s <sup>2</sup> (50G) Duration of pulse = 11ms Apply 3 successive shocks in each direction along the 3 mutually perpendicular axes. (IEC-60068-2-27-EA)	No electrical discontinuity greater than 1 μsec. shall occur. No damage to product. Contact resistance:100mΩ max.

# PRODUCT SPECIFICATION

<b>Part Number</b>	SIM7050	<b>Rev</b>	A1	<b>Date</b>	18/08/21		
<b>Product Description</b>	Micro SIM Card Connector, Retainer Type, 6 & 8 Pin, SMT, 2.45mm Profile				<b>Page</b>	4	
<b>Doc Number</b>	SIM7050	<b>Prepared</b>	<b>AO</b>	<b>Checked</b>	<b>VJ</b>	<b>Approved</b>	<b>ST</b>

## 6.3 Environmental Performance and Others.

Item	Test Condition	Requirement
Thermal Shock	5 cycles at Ta= -55°C for 0.5 hours, then change temp = 25°C MAX 5min, then, Tb = +85°C for 0.5hour, then cool to ambient. Recovery: 2hours at ambient atmosphere. EIA-364-32	No damage, Contact Resistance (Low Level) (Final) 100mΩ max
Humidity Test	The card shall be mated and exposed to the condition of +40±2 @ 90~95% humidity for 96 hours Recovery time 1~2 hours. In accordance with EIA-364-31.	No damage, Contact Resistance (Low Level) (Final) 100mΩ max. Dielectric Strength should be OK, Insulation Resistance should be 100MΩ min.
Salt Water Spray	5±1% salt concentration 24 hours 35±2°C EIA-364-26	No rusty cracks found. Contact Resistance (Low Level) (Final) 100mΩ max
Temperature Life (High)	Subject product to 85±2°C for 96 hours continuously. EIA-364-17.	Contact resistance: 100mΩ max
Temperature Rise	Mate card and measure the temperature rise of contact, when rated current is passed. In accordance with EIA-364-70 Method 1.	30°C Max
Solderability	Dip solders tails into molten solder, held at a temperature of 250±5°C up to 0.5mm from the tip of the tails for 3±0.5 seconds.	Contact solder pad has a min. 95% solder coverage
Resistance to Hand Soldering Heat	Soldering iron method Soldering Time: 3 sec. Solder Temperature: 350 °C	No damage
Resistance to Reflow Soldering Heat.	Mount connector, place in reflow oven and expose to the temperature profile shown in fig 1.0	No evidence of physical damage or abnormalities adversely affecting performance.

# PRODUCT SPECIFICATION

<b>Part Number</b>	SIM7050	<b>Rev</b>	A1	<b>Date</b>	18/08/21		
<b>Product Description</b>	Micro SIM Card Connector, Retainer Type, 6 & 8 Pin, SMT, 2.45mm Profile				<b>Page</b>	5	
<b>Doc Number</b>	SIM7050	<b>Prepared</b>	<b>AO</b>	<b>Checked</b>	<b>VJ</b>	<b>Approved</b>	<b>ST</b>

## 6.4 REFLOW SOLDERING PROFILE

Pb-free reflow profile requirements

Parameter	Specification
Average temperature gradient in preheating	2.5°C/s
Preheating Temperature	150°C~200°C
Soak time	120-180 seconds
Time above 217°C	40~120 seconds
Peak temperature in reflow	235°C~250°C
Time at peak temperature	10-50 seconds
Temperature gradient in cooling	Max -5°C/s

Temperature profile for lead-free soldering

Temperature measured on solderable termination

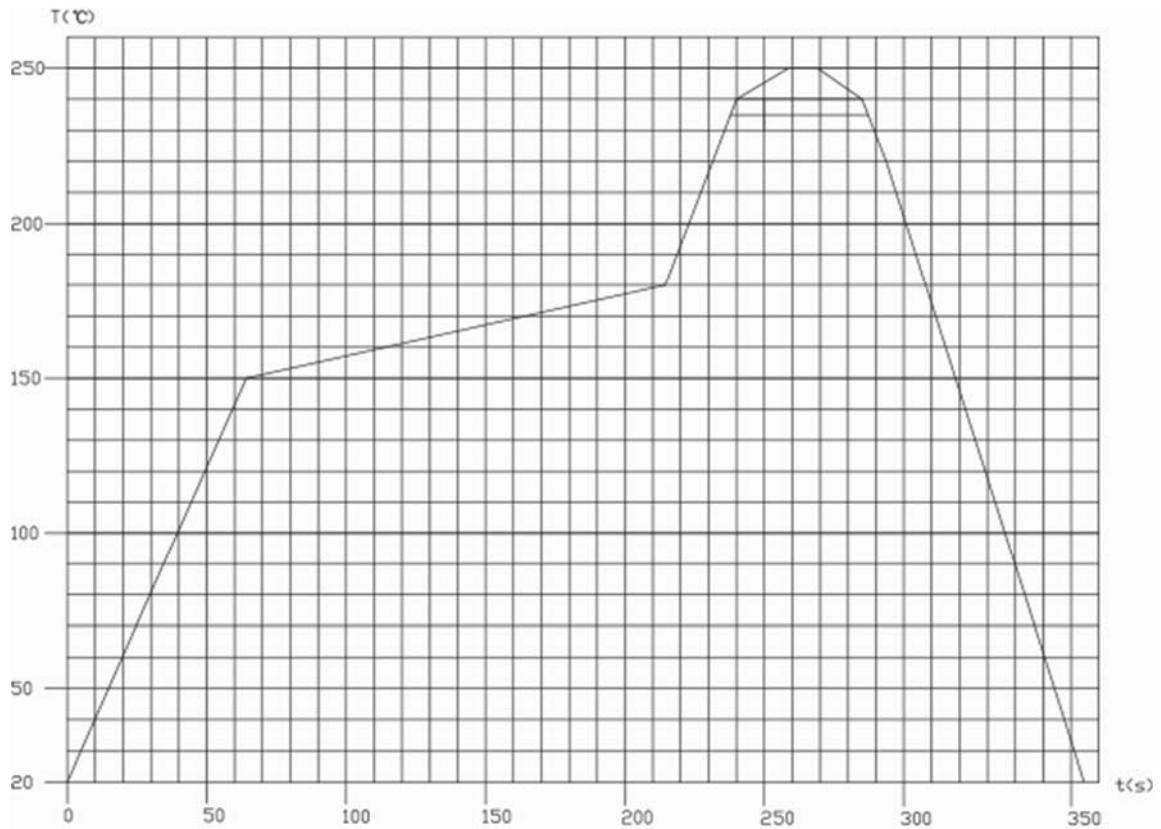

# PRODUCT SPECIFICATION

<b>Part Number</b>	SIM7050	<b>Rev</b>	A1	<b>Date</b>	18/08/21		
<b>Product Description</b>	Micro SIM Card Connector, Retainer Type, 6 & 8 Pin, SMT, 2.45mm Profile				<b>Page</b>	6	
<b>Doc Number</b>	SIM7050	<b>Prepared</b>	<b>AO</b>	<b>Checked</b>	<b>VJ</b>	<b>Approved</b>	<b>ST</b>

## 7.0 PRODUCT QUALIFICATION AND TEST SEQUENCE

Test Item	Group									
	A	B	C	D	E	F	G	H	I	J
Examination of Product	1,5	1,3	1,6	1,5	1,8	1,3	1,3	1,5	1,5	1,3
Contact Resistance	2,4		2,5	2,4	2,6			2,4	2,4	
Insulation Resistance					3,7					
Dielectric Withstanding Voltage					4					
Durability	3									
Temperature Rise		2								
Vibration			4							
Mechanical Shock			3							
Thermal Shock				3						
Humidity					5					
Solderability						2				
Resistance to reflow Soldering Heat							2			
Salt Spray								3		
High Temperature									3	
Resistance to hand Soldering Heat										2

# PRODUCT SPECIFICATION

<b>Part Number</b>	SIM7050	<b>Rev</b>	A1	<b>Date</b>	18/08/21		
<b>Product Description</b>	Micro SIM Card Connector, Retainer Type, 6 & 8 Pin, SMT, 2.45mm Profile			<b>Page</b>	7		
<b>Doc Number</b>	SIM7050	<b>Prepared</b>	<b>AO</b>	<b>Checked</b>	<b>VJ</b>	<b>Approved</b>	<b>ST</b>

## Revision details:-

Revision	Information	Page	Release Date
A	Specification Released	-	22/12/2014
A1	Change storage temperature from '-20°C to +85°C' to '-40°C to +85°C'; Change Storage Humidity from 45%~75% R.H. to 10%~95% R.H.	2	18/08/2021

## Looking for pricing, stock, or lifecycle information?

Click below to explore more details on WIN SOURCE:

 [View SIM7050-8-0-00-A on WIN SOURCE](#)

 [GCT Information](#)

## Optimize Your Supply Chain with WIN SOURCE Solutions

-  Global Sourcing Solution
-  Obsolete Management
-  Cost Control Management
-  Shortage Management
-  Alternative Solution
-  Excess Inventory Management