



**THE DATASHEET OF  
PTPS48000QDGXRQ1**



# TPS4800-Q1 100V Automotive Low I<sub>Q</sub> High Side Driver With Reverse Polarity Protection, Short-Circuit Protection and Diagnostics

## 1 Features

- AEC-Q100 automotive qualified for automotive applications
  - Device temperature grade 1: –40°C to +125°C ambient operating temperature range
- [Functional Safety-Capable](#)
  - [Documentation available to aid functional safety system design](#)
- 3.5V to 95V input range (100V absolute maximum)
- Reverse input protection down to –65V
- Integrated 11V charge pump
- Low quiescent current, 43µA in operation
- Low 1.5µA shutdown current (EN/UVLO = Low)
- Strong gate driver (2A source and sink)
- Adjustable short circuit protection (ISCP) using external R<sub>sense</sub> or MOSFET VDS sensing with adjustable delay (TMR)
- High or low-side current sense configuration (CS\_SEL)
- Fault indication ( $\overline{\text{FLT}}$ ) during short circuit fault, input under voltage and short-circuit comparator diagnosis (SCP\_TEST)
- Fault indication (FLT\_GD) for gate drive UVLO
- Adjustable input undervoltage lockout (UVLO) and overvoltage protection (OV)

## 2 Applications

- [Automotive 48V BMS](#)
- [DC/DC converter](#)
- [Power tools](#)

## 3 Description

The TPS48000-Q1 is a 100V low I<sub>Q</sub> smart high side driver with protection and diagnostics. With wide operating voltage range of 3.5V–95V, the device is suitable for 12V, 24V, and 48V system designs. The device can withstand and protect the loads from negative supply voltages down to –65V.

It has a strong (2A) gate drive that enables power switching using parallel MOSFETs in high current system designs.

The device provides adjustable short circuit protection. Auto-retry and latch-off fault behavior can be configured. By using CS+ and CS– pins, current sensing can be done either by an external sense resistor or by MOSFET VDS sensing. High side or low side current sense resistor configuration is possible by using CS\_SEL pin input. The device also features diagnosis of the internal short circuit comparator using external control on SCP\_TEST input.

Low quiescent current of 43µA (typical) in operation enables always ON system designs. Quiescent current reduces to 1.5µA (typical) with EN/UVLO low.

The TPS48000-Q1 is available in a 19-pin VSSOP package.

### Package Information

PART NUMBER	PACKAGE <sup>(1)</sup>	PACKAGE SIZE <sup>(2)</sup>
TPS48000-Q1	DGX (VSSOP, 19)	5.1mm × 3.0mm

- (1) For all available packages, see the orderable addendum at the end of the data sheet.
- (2) The package size (length × width) is a nominal value and includes pins, where applicable.

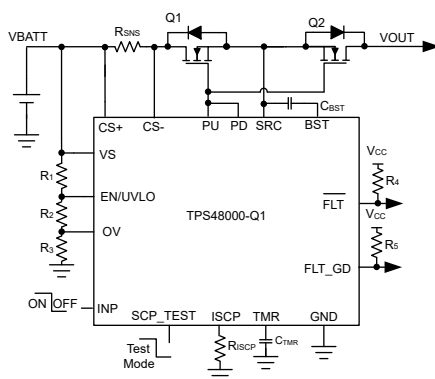

Smart High Side Driver for DC-DC

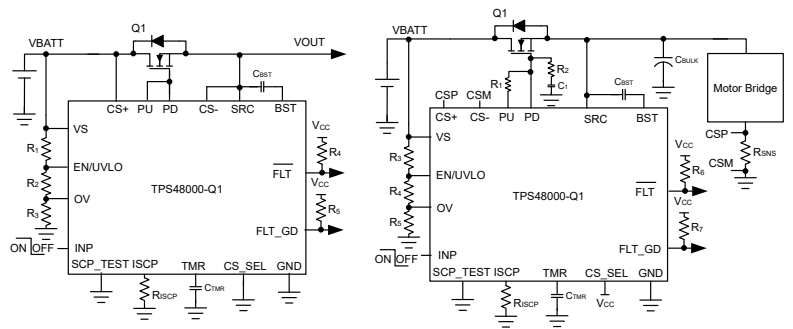

Configurations With High Side VDS Sensing and Low Side Current Sensing

## Table of Contents

<b>1 Features</b> .....	1	7.4 Device Functional Modes.....	21
<b>2 Applications</b> .....	1	<b>8 Application and Implementation</b> .....	22
<b>3 Description</b> .....	1	8.1 Application Information.....	22
<b>4 Pin Configuration and Functions</b> .....	3	8.2 Typical Application: Driving Power at all Times (PAAT) Loads.....	22
<b>5 Specifications</b> .....	5	8.3 Power Supply Recommendations.....	28
5.1 Absolute Maximum Ratings.....	5	8.4 Layout.....	29
5.2 ESD Ratings.....	5	<b>9 Device and Documentation Support</b> .....	31
5.3 Recommended Operating Conditions.....	5	9.1 Receiving Notification of Documentation Updates....	31
5.4 Thermal Information.....	6	9.2 Support Resources.....	31
5.5 Electrical Characteristics.....	6	9.3 Trademarks.....	31
5.6 Switching Characteristics.....	7	9.4 Electrostatic Discharge Caution.....	31
5.7 Typical Characteristics.....	9	9.5 Glossary.....	31
<b>6 Parameter Measurement Information</b> .....	11	<b>10 Revision History</b> .....	31
<b>7 Detailed Description</b> .....	12	<b>11 Mechanical, Packaging, and Orderable Information</b> .....	31
7.1 Overview.....	12		
7.2 Functional Block Diagram.....	12		
7.3 Feature Description.....	13		

## 4 Pin Configuration and Functions

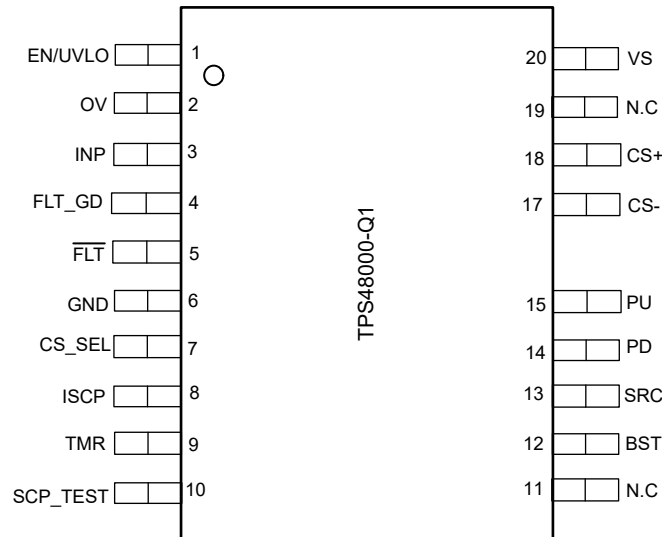

**Figure 4-1. DGX Package, 19-Pin VSSOP (Top View)**

**Table 4-1. Pin Functions**

PIN		TYPE <sup>(1)</sup>	DESCRIPTION
NAME	NO.		
EN/UVLO	1	I	EN/UVLO Input. A voltage on this pin above 1.24V enables normal operation. Forcing this pin below 0.3V shuts down the device reducing quiescent current to 1.5µA (typical). Optionally connect to the input supply through a resistive divider to set the undervoltage lockout. When EN/UVLO is left floating an internal pull down of 100nA pulls EN/UVLO low and keeps the device in shutdown state.
OV	2	I	Adjustable overvoltage threshold input. Connect a resistor ladder from input supply, OV to GND. When the voltage at OVP exceeds the overvoltage cut-off threshold then the PD is pulled down to SRC turning OFF the external FET. When the voltage at OV goes below OV falling threshold then PU gets pulled up to BST, turning ON the external FET. OV must be connected to GND when not used. When OV is left floating an internal pull down of 100nA pulls OV low and keeps PU pulled up to BST.
INP	3	I	Input Signal for external discharge FET control. CMOS compatible input reference to GND that sets the state of PD and PU pins. INP has an internal weak pull down of 100nA to GND to keep PD pulled to SRC when INP is left floating.
FLT_GD	4	O	Open Drain Fault Output for gate drive UVLO. This pin asserts low when gate drive across PU to SRC is above 7.5V.
FLT	5	O	Open Drain Fault Output. This pin asserts low during short circuit fault, input UVLO, overvoltage and during SCP comparator diagnosis. If FLT feature is not desired then connect it to GND.
GND	6	G	Connect GND to system ground.
CS_SEL	7	I	Current sense select input. Connect this pin to ground to activate high side current sense. Drive this pin to >2V to activate low side current sensing. CS_SEL has an internal weak pull down of 100nA to GND.

**Table 4-1. Pin Functions (continued)**

PIN		TYPE <sup>(1)</sup>	DESCRIPTION
NAME	NO.		
ISCP	8	I	Short circuit detection setting. A resistor across ISCP to GND sets the short circuit current comparator threshold. If short-circuit protection feature is not desired then connect CS+, CS-, VS pins together and connect ISCP, TMR pins to GND.
TMR	9	I	Fault Timer Input. A capacitor across TMR pin to GND sets the times for fault turn-off. Leave it open for fastest setting. If short-circuit protection feature is not desired then connect CS+, CS-, VS pins together and connect ISCP, TMR pins to GND.
SCP_TEST	10	I	Internal short circuit comparator (SCP) diagnosis input. When SCP_TEST is driven low to high with INP pulled high, the internal SCP comparator operation is checked. $\overline{FLT}$ goes low and PD gets pulled to SRC if SCP comparator is functional. Connect SCP_TEST pin to GND if this feature is not desired. SCP_TEST has an internal weak pull down of 100nA to GND.
N.C	11	—	No connect.
BST	12	O	High Side Bootstrapped Supply. An external capacitor with a minimum value of $>Q_{g(tot)}$ of the external FET must be connected between this pin and SRC.
SRC	13	O	Source connection of the external FET.
PD	14	O	High Current Gate Driver Pull-Down. This pin pulls down to SRC. For the fastest turn-off, tie this pin directly to the gate of the external high side MOSFET.
PU	15	O	High Current Gate Driver Pull-Up. This pin pulls up to BST. Connect this pin to PD for maximum gate drive transition speed. A resistor can be connected between this pin and the gate of the external MOSFET to control the in-rush current during turn-on.
CS-	17	I	Current sense negative input.
CS+	18	I	Current sense positive input.
N.C	19	—	No connect.
VS	20	P	Supply pin of the controller.

(1) I = input, O = output, I/O = input and output, P = power, G = Ground

## 5 Specifications

### 5.1 Absolute Maximum Ratings

over operating free-air temperature range (unless otherwise noted)<sup>(1)</sup>

		MIN	MAX	UNIT
Input Pins	VS, CS+, CS– to GND	–65	100	V
	SRC to GND	–65	100	
	PU, PD, BST to SRC	–0.3	19	
	ISCP, TMR, SCP_TEST to GND	–0.3	5.5	
	EN/UVLO, OV, INP, CS_SEL, $V_{(VS)} > 0$ V	–1	70	
	EN/UVLO, OV, INP, CS_SEL, $V_{(VS)} \leq 0$ V	$V_{(VS)}$	$(70 + V_{(VS)})$	
	CS+ to CS–	–1	100	V
	FLT, FLT_GD to GND	–1	20	V
Sink current	$I_{(FLT)}$ , $I_{(WAKE)}$		10	mA
	$I_{(CS+)}$ , $I_{(CS-)}$ , 1msec	–100	100	mA
Output Pins	PU, PD, G2, BST to GND	–65	112	V
Operating junction temperature, $T_j$ <sup>(2)</sup>		–40	150	°C
Storage temperature, $T_{stg}$		–55	150	

- Operation outside the Absolute Maximum Ratings may cause permanent device damage. Absolute Maximum Ratings do not imply functional operation of the device at these or any other conditions beyond those listed under Recommended Operating Conditions. If used outside the Recommended Operating Conditions but within the Absolute Maximum Ratings, the device may not be fully functional, and this may affect device reliability, functionality, performance, and shorten the device lifetime.
- High junction temperatures degrade operating lifetimes. Operating lifetime is de-rated for junction temperatures greater than 125°C.

### 5.2 ESD Ratings

			VALUE	UNIT	
$V_{(ESD)}$	Electrostatic discharge	Human body model (HBM), per AEC Q100-002 <sup>(1)</sup>	±2000	V	
		Charged device model (CDM), per AEC Q100-011	Corner pins (EN/UVLO, VS, SCP_TEST)		±750
			Other pins		±500

- AEC Q100-002 indicates that HBM stressing shall be in accordance with the ANSI/ESDA/JEDEC JS-001 specification.

### 5.3 Recommended Operating Conditions

over operating free-air temperature range (unless otherwise noted)<sup>(1)</sup>

		MIN	NOM	MAX	UNIT
Input Pins	VS to GND	3.5		95	V
	Minimum voltage on VS pin for Short Circuit Protection	4			
	EN/UVLO, INP, CS_SEL to GND	0		65	
Output Pins	FLT, WAKE to GND	0		15	V
External Capacitor	VS, SRC to GND	22			nF
	BST to SRC	0.1			µF
$T_j$	Operating Junction temperature <sup>(2)</sup>	–40		150	°C

- Recommended Operating Conditions are conditions under which the device is intended to be functional. For specifications and test conditions, see Electrical Characteristics.
- High junction temperatures degrade operating lifetimes. Operating lifetime is de-rated for junction temperatures greater than 125°C.

## 5.4 Thermal Information

THERMAL METRIC <sup>(1)</sup>		TPS4800-Q1	
		DGX	
		19 PINS	
			UNIT
$R_{\theta JA}$	Junction-to-ambient thermal resistance	92.3	°C/W
$R_{\theta JC(top)}$	Junction-to-case (top) thermal resistance	28.6	°C/W
$R_{\theta JB}$	Junction-to-board thermal resistance	47.5	°C/W
$\Psi_{JT}$	Junction-to-top characterization parameter	0.6	°C/W
$\Psi_{JB}$	Junction-to-board characterization parameter	47.2	°C/W

(1) For more information about traditional and new thermal metrics, see the [Semiconductor and IC Package Thermal Metrics](#) application report.

## 5.5 Electrical Characteristics

$T_J = -40\text{ }^{\circ}\text{C}$  to  $+125\text{ }^{\circ}\text{C}$ .  $V_{(VS)} = 48\text{ V}$ ,  $V_{(BST-SRC)} = 11\text{ V}$

PARAMETER		TEST CONDITIONS	MIN	TYP	MAX	UNIT
<b>SUPPLY VOLTAGE</b>						
VS	Operating input voltage		3.5		95	V
$V_{(S\_PORR)}$	Input supply POR threshold, rising		1.78	2.5	3.27	V
$V_{(S\_PORF)}$	Input supply POR threshold, falling		1.71	2.36	3.1	V
	Total System Quiescent current, $I_{(GND)}$	$V_{(EN/UVLO)} = 2\text{ V}$		46	55	$\mu\text{A}$
	Total System Quiescent current, $I_{(GND)}$	$V_{(EN/UVLO)} = 2\text{ V}$ , $-40\text{ }^{\circ}\text{C} \leq T_J \leq +85\text{ }^{\circ}\text{C}$			53	$\mu\text{A}$
$I_{(SHDN)}$	SHDN current, $I_{(GND)}$	$V_{(EN/UVLO)} = 0\text{ V}$ , $V_{(SRC)} = 0\text{ V}$		0.75	3.3	$\mu\text{A}$
$I_{(REV)}$	$I_{(VS)}$ leakage current during Reverse Polarity	$0\text{ V} \leq V_{(VS)} \leq -65\text{ V}$	19	22.4	37	$\mu\text{A}$
<b>ENABLE, UNDERVOLTAGE LOCKOUT (EN/UVLO), SHORT CIRCUIT COMPARATOR TEST (SCP_TEST) INPUT</b>						
$V_{(UVLOR)}$	UVLO threshold voltage, rising		1.176	1.23	1.287	V
$V_{(UVLOF)}$	UVLO threshold voltage, falling		1.09	1.136	1.184	V
$V_{(ENR)}$	Enable threshold voltage for low Iq shutdown, rising				1	V
$V_{(ENF)}$	Enable threshold voltage for low Iq shutdown, falling		0.3			V
$I_{(EN/UVLO)}$	Enable input leakage current	$V_{(EN/UVLO)} = 70\text{ V}$	130		478	nA
$V_{(SCP\_TEST\_H)}$	SCP test mode rising threshold				2	V
$V_{(SCP\_TEST\_L)}$	SCP test mode falling threshold		0.8			V
$I_{(SCP\_TEST)}$	SCP_TEST input leakage current			90	700	nA
<b>OVER VOLTAGE PROTECTION (OV) INPUT</b>						
$V_{(OVR)}$	Overvoltage threshold input, rising		1.171	1.225	1.278	V
$V_{(OVF)}$	Overvoltage threshold input, falling		1.088	1.138	1.186	V
$I_{(OV)}$	OV Input leakage current			86	200	nA
<b>CHARGE PUMP (BST-SRC)</b>						
$I_{(BST)}$	Charge Pump Supply current	$V_{(BST-SRC)} = 10\text{ V}$ , $V_{(EN/UVLO)} = 2\text{ V}$	190	345	466	$\mu\text{A}$
$V_{(BST\_UVLOR)}$	$V_{(BST-SRC)}$ UVLO voltage threshold, rising	$V_{(EN/UVLO)} = 2\text{ V}$	8.1	9	9.9	V
$V_{(BST\_UVLOF)}$	$V_{(BST-SRC)}$ UVLO voltage threshold, falling	$V_{(EN/UVLO)} = 2\text{ V}$	7.28	8.2	8.9	V
$V_{(BST-SRC\_ON)}$	Charge Pump Turn ON voltage	$V_{(EN/UVLO)} = 2\text{ V}$	9.3	10.3	11.4	V
$V_{(BST-SRC\_OFF)}$	Charge Pump Turn OFF voltage	$V_{(EN/UVLO)} = 2\text{ V}$	10.4	11.6	12.8	V
$V_{(BST-SRC)}$	Charge Pump Voltage at $V_{(VS)} = 3.5\text{ V}$	$V_{(EN/UVLO)} = 2\text{ V}$	9.1	10.5	11.62	V
<b>GATE DRIVER OUTPUTS (G1PU, G1PD)</b>						

## 5.5 Electrical Characteristics (continued)

 $T_J = -40\text{ }^\circ\text{C to }+125\text{ }^\circ\text{C}$ .  $V_{(VS)} = 48\text{ V}$ ,  $V_{(BST - SRC)} = 11\text{ V}$ 

PARAMETER		TEST CONDITIONS	MIN	TYP	MAX	UNIT
$I_{(PU)}$	Peak Source Current			1.69		A
$I_{(PD)}$	Peak Sink Current			2		A
$V_{(G\_GOOD)}$	VGS good threshold		5.5	7	8.3	V
<b>SHORT CIRCUIT PROTECTION (ISCP)</b>						
$I_{(SCP)}$	SCP Input Bias current		8.4	10	12.33	$\mu\text{A}$
$V_{(SCP)}$	SCP threshold	$R_{(ISCP)} = 140.5\text{ k}\Omega$		300		mV
		$R_{(ISCP)} = 28\text{ k}\Omega$	60	75	90	mV
		$R_{(ISCP)} = 10.5\text{ k}\Omega$	32	40	48	mV
		$R_{(ISCP)} = 500\text{ }\Omega$	15	20	25	mV
		$R_{(ISCP)} = \text{Open}$			757	mV
$V_{(SCP)}$	SCP threshold with external bias on ISCP pin	$V_{(ISCP)} = 1.405\text{ V}$	283	300	315	mV
		$V_{(ISCP)} = 280\text{ mV}$	67.8	75	81.7	mV
		$V_{(ISCP)} = 105\text{ mV}$	33.3	40	46.2	mV
<b>DELAY TIMER (TMR)</b>						
$I_{(TMR\_SRC\_CB)}$	TMR source current		67	87	104	$\mu\text{A}$
$I_{(TMR\_SRC\_FLT)}$	TMR source current		1.4	2.73	3.8	$\mu\text{A}$
$I_{(TMR\_SNK)}$	TMR sink current		2.17	2.8	3.4	$\mu\text{A}$
$V_{(TMR\_SC)}$			0.93	1.1	1.2	V
$V_{(TMR\_LOW)}$			0.15	0.21	0.25	V
$N_{(A-R\text{ Count})}$				32		
<b>INPUT CONTROL (INP), FAULT FLAGS (FLT, FLT_GD)</b>						
$R_{(FLT)}$ , $R_{(FLT\_GD)}$	FLT, FLT_GD Pull-down resistance		53	85	107	$\Omega$
$I_{(FLT)}$ , $I_{(FLT\_GD)}$	FLT, FLT_GD Input leakage current	$0\text{ V} \leq V_{(FLT)} \leq 20\text{ V}$			410	nA
$V_{(INP\_H)}$					2	V
$V_{(INP\_L)}$			0.8			V
$I_{(INP)}$	INP Input leakage current			89	206	nA
$V_{(CS\_SEL\_H)}$	CS_SEL threshold for low side sensing		1.35		2	V
$V_{(CS\_SEL\_L)}$	CS_SEL threshold for high side sensing		0.8		1.36	V
$I_{(CS\_SEL)}$	CS_SEL Input leakage current		10	88.8	200	nA

## 5.6 Switching Characteristics

 $T_J = -40\text{ }^\circ\text{C to }+125\text{ }^\circ\text{C}$ .  $V_{(VS)} = 48\text{ V}$ ,  $V_{(BST - SRC)} = 11\text{ V}$ 

PARAMETER		TEST CONDITIONS	MIN	TYP	MAX	UNIT
$t_{PU(INP\_H)}$	INP Turn ON propagation Delay	INP $\uparrow$ to PU $\uparrow$ , $C_L = 47\text{ nF}$	0.32		1.53	$\mu\text{s}$
$t_{PD(INP\_L)}$	INP Turn OFF propagation Delay	INP $\downarrow$ to PD $\downarrow$ , $C_L = 47\text{ nF}$		0.36	1	$\mu\text{s}$
$t_{PD(EN\_OFF)}$	EN Turn OFF Propagation Delay	EN $\downarrow$ to PD $\downarrow$ , $C_L = 47\text{ nF}$	2.2	4.6	6	$\mu\text{s}$
$t_{PD(UVLO\_OFF)}$	UVLO Turn OFF Propagation Delay	UVLO $\downarrow$ to PD $\downarrow$ and $\overline{FLT}$ $\downarrow$ , $C_L = 47\text{ nF}$	2.8	4.8	6	$\mu\text{s}$
$t_{PD(OV\_OFF)}$	OV Turn Off propagation Delay	OV $\uparrow$ to PD $\downarrow$ and $\overline{FLT}$ $\downarrow$ , $C_L = 47\text{ nF}$		4.5	5.4	$\mu\text{s}$
$t_{SC}$	Hard Short-circuit protection propagation delay	$V_{(CS+ - CS-)} \uparrow V_{(SCP)}$ to PD $\downarrow$ , $C_L = 47\text{ nF}$ , $C_{(TMR)} = \text{Open}$			4	$\mu\text{s}$
$t_{SC\_PUS}$	Short-circuit protection propagation delay during power up with output short circuit	$C_{TMR} = \text{Open}$			10	$\mu\text{s}$

## 5.6 Switching Characteristics (continued)

$T_J = -40\text{ }^\circ\text{C}$  to  $+125\text{ }^\circ\text{C}$ .  $V_{(VS)} = 48\text{ V}$ ,  $V_{(BST-SRC)} = 11\text{ V}$

PARAMETER		TEST CONDITIONS	MIN	TYP	MAX	UNIT
$t_{PD(FLT\_SC)}$	$\overline{FLT}$ assertion delay during short circuit	$V_{(CS+-CS-)} \uparrow V_{(SCP)}$ to $\overline{FLT} \downarrow$ , $C_{(TMR)} = \text{Open}$		10.5	15	$\mu\text{s}$
$F_{ISCP}$	ISCP Pulse current frequency			1.18		kHz
$t_{PD(FLT\_GD)}$	FLT assertion delay during Gate Drive UVLO	$V_{(PU-SRC)} \uparrow V_{(BSTUVLOR)}$ to $FLT\_GD \downarrow$		120		$\mu\text{s}$
$t_{PD(FLT\_GD)}$	FLT de-assertion delay during Gate Drive UVLO	$V_{(PU-SRC)} \downarrow V_{(BSTUVLOR)}$ to $FLT\_GD \uparrow$		127		$\mu\text{s}$

### 5.7 Typical Characteristics

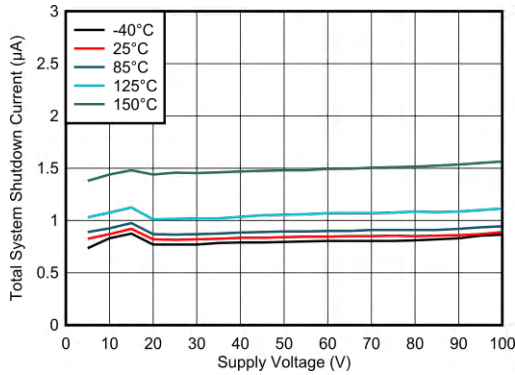

Figure 5-1. Shutdown Supply Current vs Supply Voltage

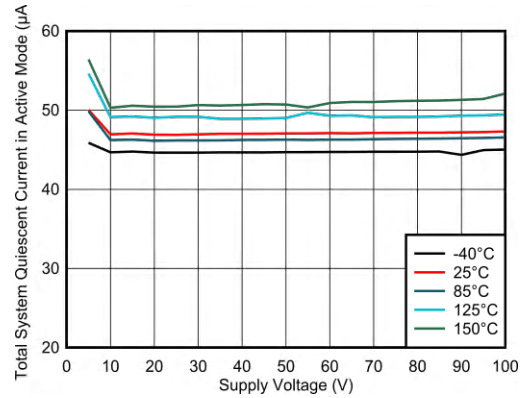

Figure 5-2. Operating Quiescent Current in Active Mode vs Supply Voltage

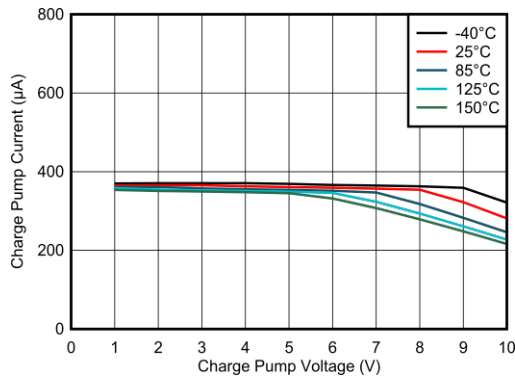

Figure 5-3. Charge Pump Current vs Charge Pump Voltage

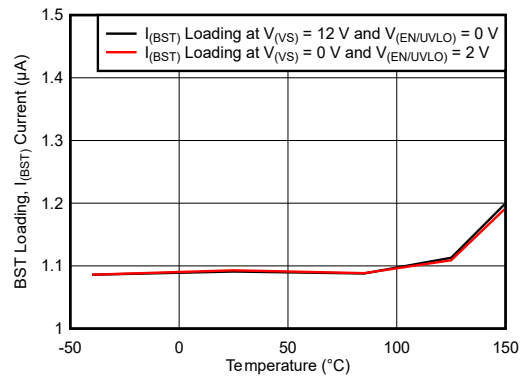

Figure 5-4. BST Loading Current ( $I_{BST}$ ) vs Temperature

$V_{(BST)} = 15\text{ V}$        $V_{(SRC)} = 0\text{ V}$

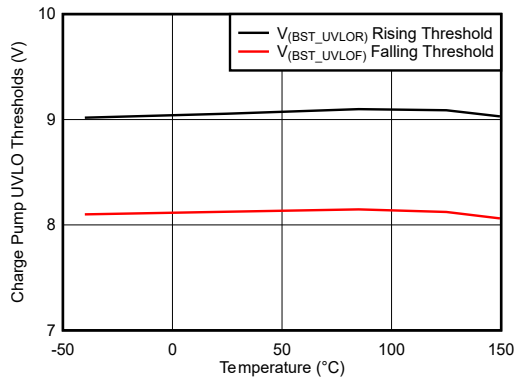

Figure 5-5. Charge Pump UVLO Thresholds vs Temperature

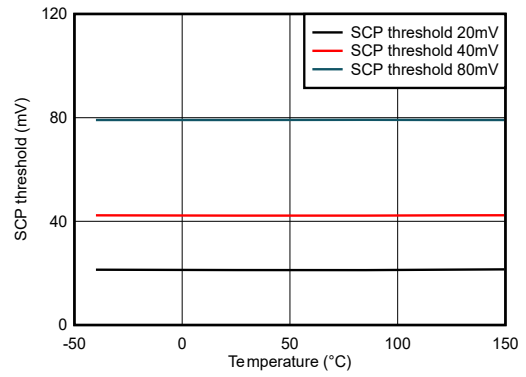

Figure 5-6. Short-Circuit Threshold ( $V_{SCP}$ ) vs Temperature

### 5.7 Typical Characteristics (continued)

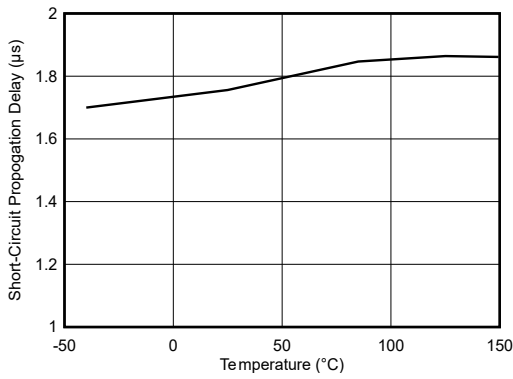

Figure 5-7. Short Circuit Protection Response Time (t<sub>sc</sub>) vs Temperature

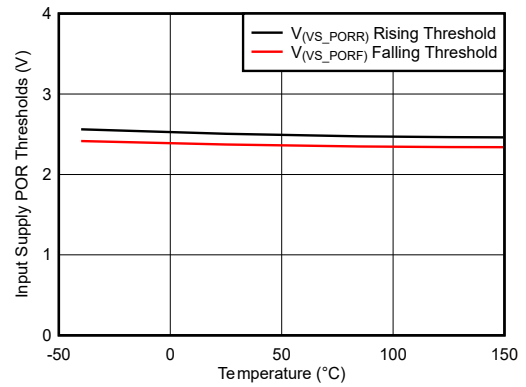

Figure 5-8. Input Supply POR Thresholds vs Temperature

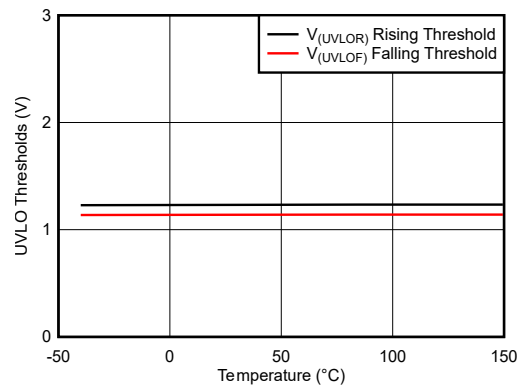
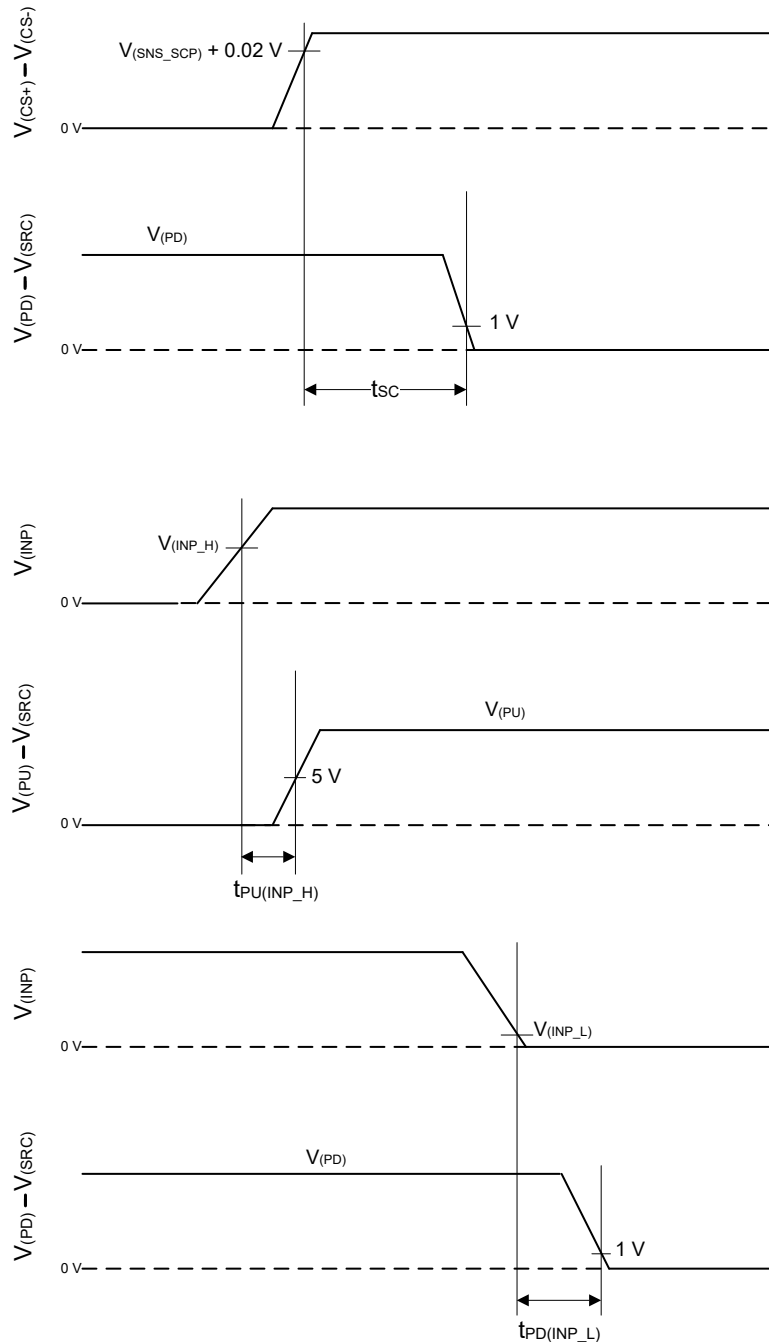

Figure 5-9. Input Supply UVLO Thresholds vs Temperature

## 6 Parameter Measurement Information



**Figure 6-1. Timing Waveforms**

## 7 Detailed Description

### 7.1 Overview

The TPS48000-Q1 is a 100-V low IQ smart high side driver with protection and diagnostics. With wide operating voltage range of 3.5 V–95V, the device is suitable for 12V, 24V and 48V system designs. The device can withstand and protect the loads from negative supply voltages down to –65V.

It has a strong 1.69A/2A peak source/sink gate driver that enables power switching using parallel FETs in high current system designs.

The device provides configurable short circuit protection using ISCP and TMR pins for adjusting the threshold and response time respectively. Auto-retry and latch-off fault behavior can be configured. With TPS48000-Q1, current sensing can be done either by an external sense resistor or by MOSFET VDS sensing. High side or low side current sense resistor configuration is possible by using CS\_SEL pin input. Diagnosis of the integrated short circuit comparator is possible using external control on SCP\_TEST input.

The device has adjustable under voltage and overvoltage protection.

The device indicates fault ( $\overline{\text{FLT}}$ ) on open drain output during during short circuit and input under voltage, overvoltage conditions. It also have a dedicate fault indication (FLT\_GD) to indicate the gate drive UVLO condition.

Low Quiescent Current 43 $\mu$ A (typical) in operation enables always ON system designs. Quiescent current reduces to 1.5 $\mu$ A (typical) with EN/UVLO low.

### 7.2 Functional Block Diagram

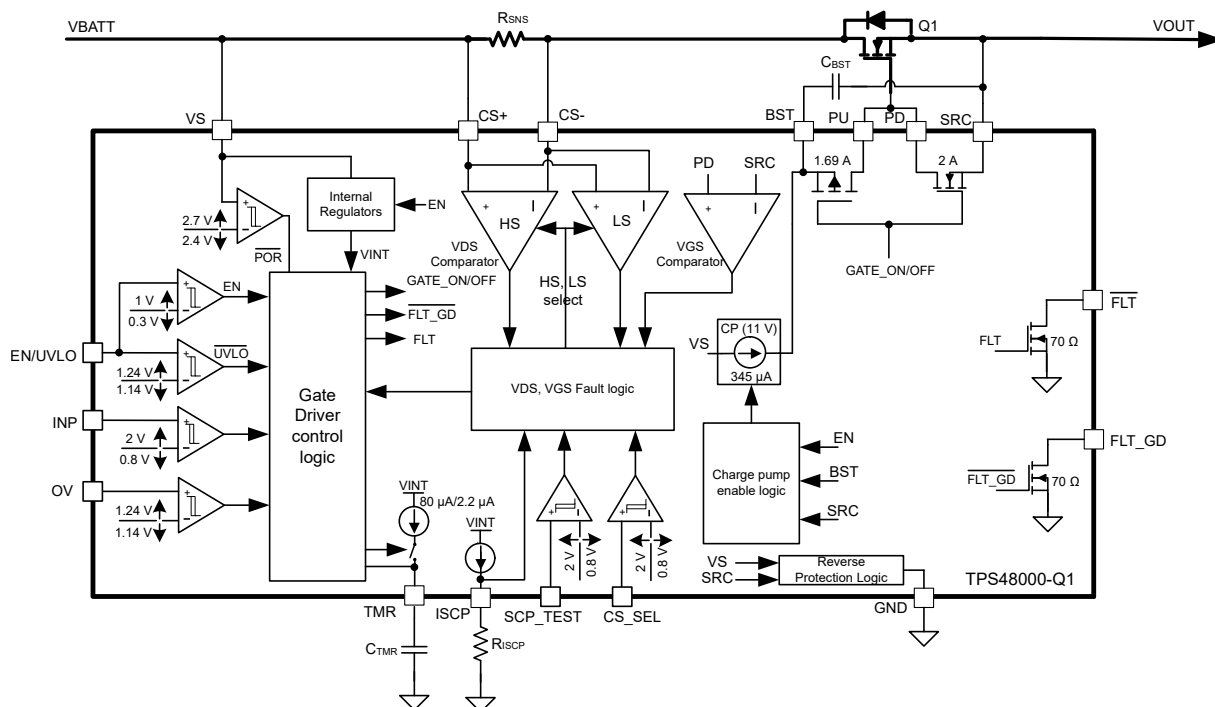



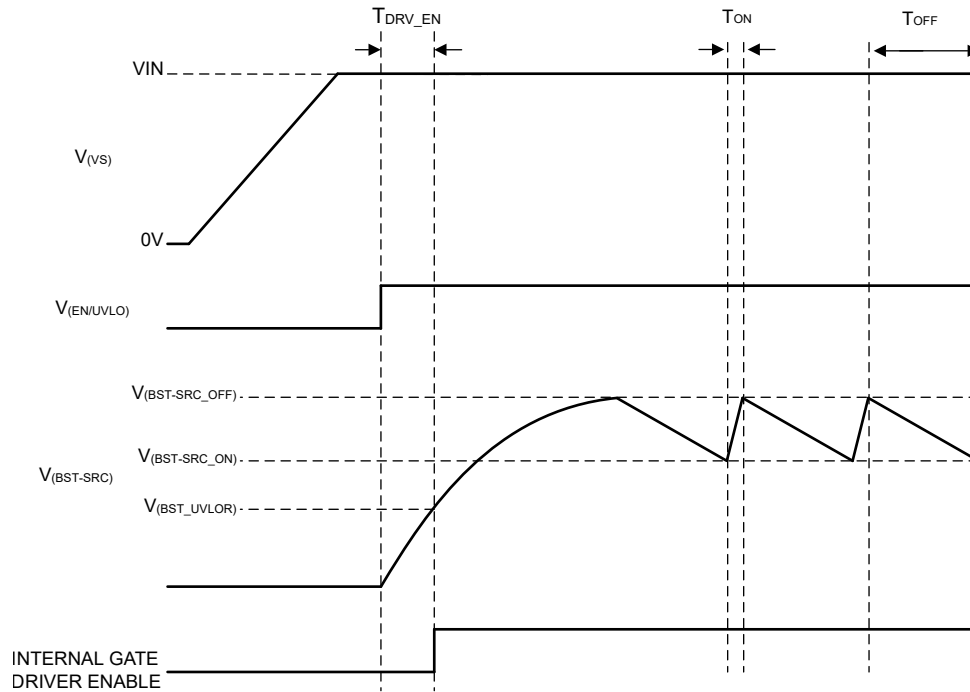

**Figure 7-2. Charge Pump Operation**

Use the following equation to calculate the initial gate driver enable delay:

$$T_{DRV\_EN} = \frac{C_{BST} \times V_{(BST\_UVLOR)}}{345 \mu A} \tag{1}$$

Where,

$C_{BST}$  is the charge pump capacitance connected across BST and SRC pins.

$V_{(BST\_UVLOR)} = 9.5V$  (max).

If  $T_{DRV\_EN}$  must be reduced then pre-bias BST terminal externally using an external  $V_{AUX}$  supply through a low leakage diode  $D_1$  as shown in [Figure 7-3](#). With this connection,  $T_{DRV\_EN}$  reduces to 400µs. TPS48000-Q1 application circuit with external supply to BST is shown in [Figure 7-3](#).

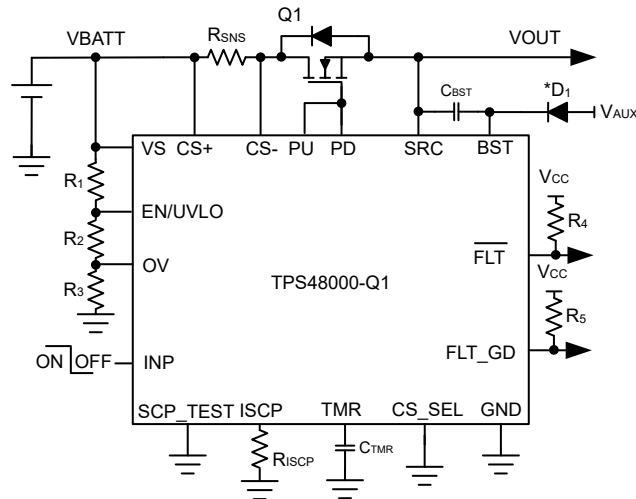

Figure 7-3. TPS48000-Q1 Application Circuit With External Supply to BST

**Note**

$V_{AUX}$  can be supplied by external regulated supply ranging between 8V and 18V.

**7.3.2 Capacitive Load Driving Using FET Gate (PU, PD) Slew Rate Control**

Certain end equipments like automotive power distribution unit power different loads including other ECUs. These ECUs can have large input capacitances. If power to the ECUs is switched on in uncontrolled way, large inrush currents can occur potentially damaging the power FETs. To limit the inrush current during capacitive load switching, the following system design technique can be used with TPS48000-Q1.

For limiting inrush current during turn ON of the FET with capacitive loads, use  $R_1$ ,  $R_2$ ,  $C_1$  as shown in Figure 7-4. The  $R_1$  and  $C_1$  components slow down the voltage ramp rate at the gate of the FET. The FET source follows the gate voltage resulting in a controlled voltage ramp across the output capacitors.

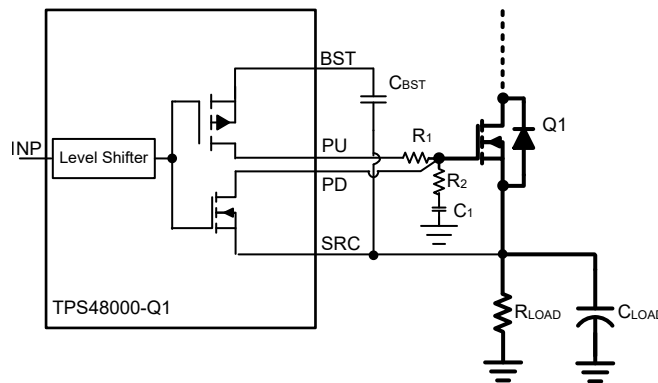

Figure 7-4. Inrush Current limiting

Use the Equation 2 to calculate the inrush current during turn-ON of the FET.

$$I_{INRUSH} = C_{LOAD} \times \frac{V_{BATT}}{T_{charge}} \quad (2)$$

$$C_1 = \frac{0.63 \times V_{(BST - SRC)} \times C_{LOAD}}{R_1 \times I_{INRUSH}} \tag{3}$$

Where,

$C_{LOAD}$  is the load capacitance,

$V_{BATT}$  is the input voltage and  $T_{charge}$  is the charge time,

$V_{(BST-SRC)}$  is the charge pump voltage (11V),

Use a damping resistor  $R_2$  (~ 10Ω) in series with  $C_1$ . Equation 3 can be used to compute required  $C_1$  value for a target inrush current. A 100kΩ resistor for  $R_1$  can be a good starting point for calculations.

Connecting PD pin of TPS48000-Q1 directly to the gate of the external FET ensures fast turn OFF without any impact of  $R_1$  and  $C_1$  components.

$C_1$  results in an additional loading on  $C_{BST}$  to charge during turn-ON. Use below equation to calculate the required  $C_{BST}$  value:

$$C_{BST} = \frac{Q_{g(total)}}{\Delta V_{BST}} + 10 \times C_1 \tag{4}$$

Where,

$Q_{g(total)}$  is the total gate charge of the FET.

$\Delta V_{BST}$  (1V typical) is the ripple voltage across BST to SRC pins.

### 7.3.3 Short-Circuit Protection

The TPS48000-Q1 feature adjustable short circuit protection. The threshold and response time can be adjusted using  $R_{ISCP}$  resistor and  $C_{TMR}$  capacitor respectively. The device senses the voltage across  $CS+$  and  $CS-$  pins. These pins can be connected across the FET drain and source terminals for FET  $R_{DSON}$  sensing or across an external high and low side current sense resistor ( $R_{SNS}$ ) as shown in Figure 7-5, Figure 7-6, , Figure 7-7 and Figure 7-8 respectively.

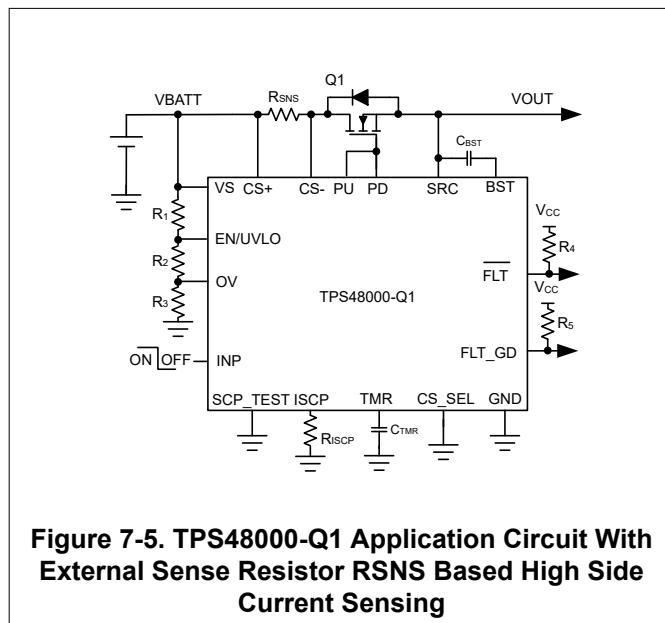

**Figure 7-5. TPS48000-Q1 Application Circuit With External Sense Resistor  $R_{SNS}$  Based High Side Current Sensing**

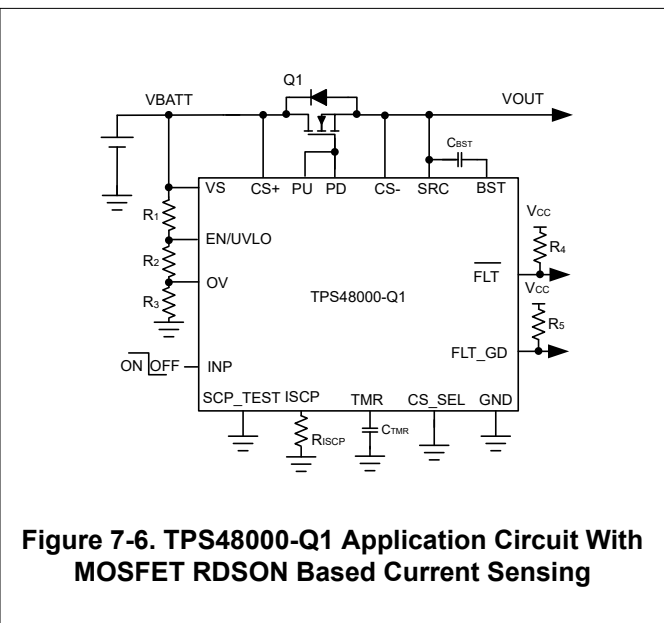

**Figure 7-6. TPS48000-Q1 Application Circuit With MOSFET  $R_{DSON}$  Based Current Sensing**

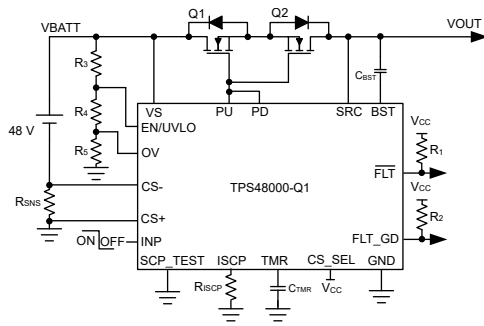

**Figure 7-7. TPS48000-Q1 Application Circuit With External Sense Resistor RSNS Based Low Side Current Sensing on Battery Side**

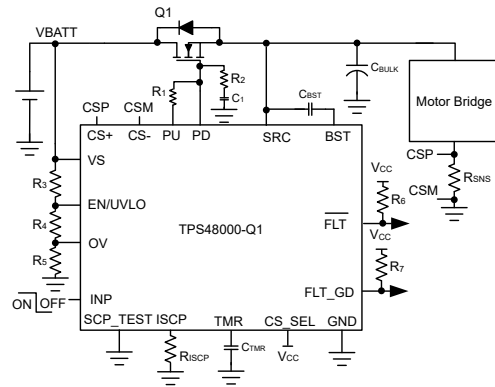

**Figure 7-8. TPS48000-Q1 Application Circuit With External Sense Resistor RSNS Based Low Side Current Sensing**

Set the short-circuit detection threshold using an external  $R_{ISCP}$  resistor across ISCP and GND pins. Use Equation 5 to calculate the required  $R_{ISCP}$  value:

$$R_{ISCP} (\Omega) = \frac{(I_{SC} \times R_{SNS} - 19 \text{ mV})}{2 \mu\text{A}} \quad (5)$$

Where,

$R_{SNS}$  is the high or low side current sense resistor value or the FET  $R_{DS(ON)}$  value.

$I_{SC}$  is the desired short circuit current level.

The short circuit protection response is fastest with no  $C_{TMR}$  cap connected across TMR and GND pins.

With device powered ON and EN/UVLO, INP pulled high, During  $Q_1$  turn ON, first VGS of external FET is sensed by monitoring the voltage across PD to SRC. Once PD to SRC voltage raises above  $V_{(G\_GOOD)}$  (7.5V typical) threshold which ensures that the external FET is enhanced, then the SCP comparator output is monitored. If the sensed voltage across CS+ and CS- exceeds the short-circuit set point ( $V_{SCP}$ ), PD pulls low to SRC and FLT asserts low. Subsequent events can be set either to be auto-retry or latch off as described in following sections.

VGS of external FET ( $Q_1$ ) is only monitored when CS\_SEL is pulled low. VGS of external FET ( $Q_1$ ) is not monitored for low side current sensing as shown in Figure 7-7 and Figure 7-8.

#### Note

Short-circuit threshold can also be set by connecting external bias voltage on ISCP pin via buffer instead of  $R_{ISCP}$  resistor enabling system design with improved SCP threshold accuracy as mentioned in electrical characteristics table. The external bias voltage to be forced on ISCP pin can be calculated by below equation:

$$V_{(SCP\_BIAS)} \text{ in mV} = I_{SC} \times R_{SNS} \times 5 - 95\text{mV}$$

#### 7.3.3.1 Short-Circuit Protection With Auto-Retry

The  $C_{TMR}$  programs the short-circuit protection delay ( $t_{SC}$ ) and auto-retry time ( $t_{RETRY}$ ). Once the voltage across CS+ and CS- exceeds the set point, the  $C_{TMR}$  starts charging with  $80\mu\text{A}$  pull-up current.

After  $C_{TMR}$  charges to  $V_{(TMR\_SC)}$ , PD pulls low to SRC and  $\overline{FLT}$  asserts low providing warning on impending FET turn OFF. Post this event, the auto-retry behavior starts. The  $C_{TMR}$  capacitor starts discharging with 2.5uA pulldown current. After the voltage reaches  $V_{(TMR\_LOW)}$  level, the capacitor starts charging with 2.2uA pullup. After 32 charging-discharging cycles of  $C_{TMR}$  the FET turns ON back and  $\overline{FLT}$  de-asserts.

The device retry time ( $t_{RETRY}$ ) is based on  $C_{TMR}$  for the first time as per Equation 7.

Use Equation 6 to calculate the  $C_{TMR}$  capacitor to be connected across TMR and GND.

$$C_{TMR} = \frac{I_{TMR} \times t_{SC}}{1.1} \tag{6}$$

Where,

$I_{TMR}$  is internal pull-up current of 80μA.

$t_{SC}$  is desired short-circuit response time.

Leave TMR floating for fastest short-circuit response time.

$$t_{RETRY} = 22.7 \times 10^6 \times C_{TMR} \tag{7}$$

If the short-circuit pulse duration is below  $t_{SC}$  then the FET remains ON and  $C_{TMR}$  gets discharged using internal pull down switch.

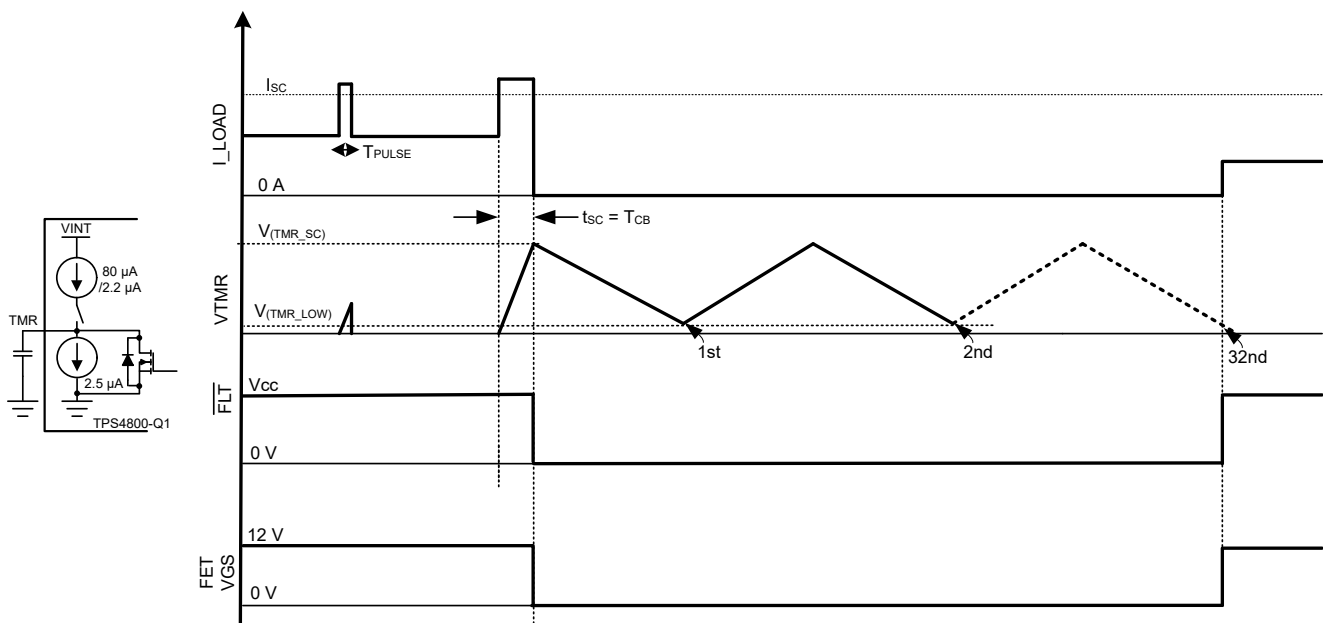

Figure 7-9. Short-Circuit Protection With Auto-Retry

### 7.3.3.2 Short-Circuit Protection With Latch-Off

Connect an approximately 100kΩ resistor across  $C_{TMR}$  as shown in . With this resistor, during the charging cycle, the voltage across  $C_{TMR}$  gets clamped to a level below  $V_{(TMR\_SC)}$  resulting in a latch-off behavior and  $\overline{FLT}$  asserts low at same time.

Use Equation 8 to calculate  $C_{TMR}$  capacitor to be connected between TMR and GND for  $R_{TMR} = 100k\Omega$ .

$$C_{TMR} = \frac{t_{SC}}{R_{TMR} \times \ln\left(\frac{1}{1 - \frac{1.1}{R_{TMR} \times 80 \mu A}}\right)} \quad (8)$$

Where,

$I_{TMR}$  is internal pull-up current of 80µA.

$t_{SC}$  is desired short-circuit response time.

Toggle INP or EN/UVLO (below  $V_{(ENF)}$ ) or power cycle VS below  $V_{(VS\_PORF)}$  to reset the latch. At low edge, the timer counter is reset and  $C_{TMR}$  is discharged. PU pulls up to BST when INP is pulled high.

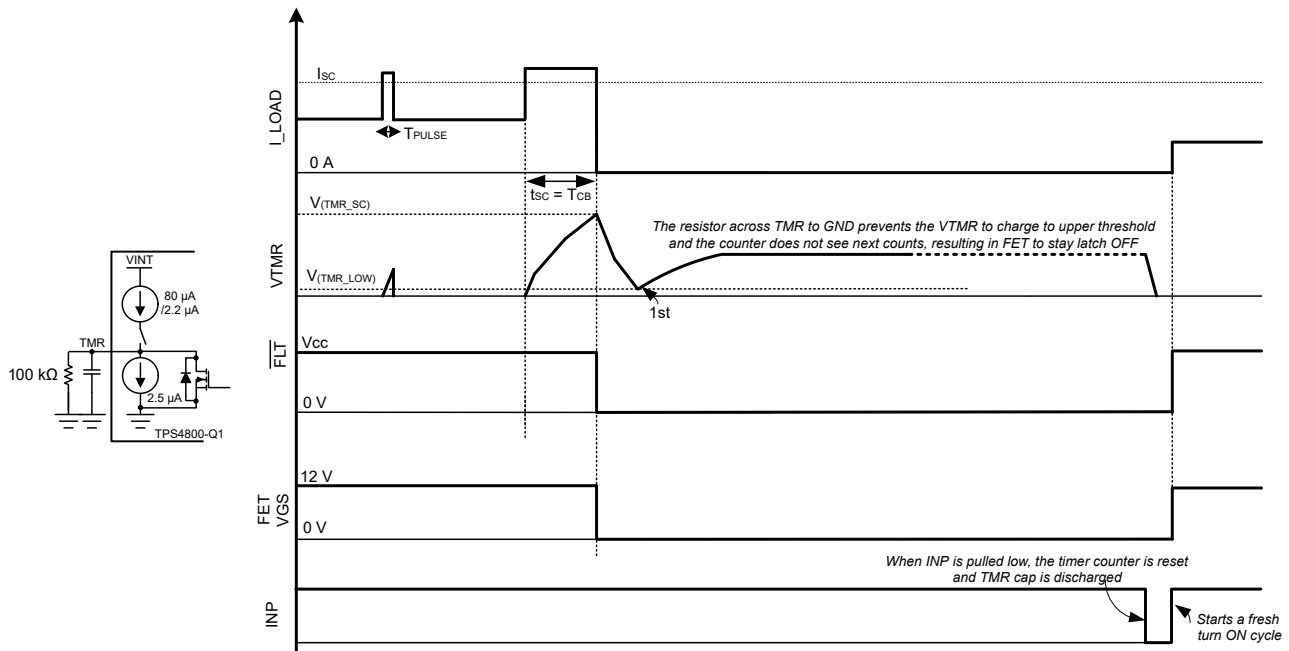
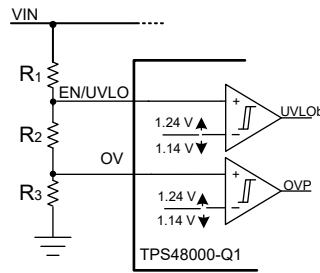

Figure 7-10. Short-Circuit Protection With Latch-Off

### 7.3.4 Overvoltage (OV) and Undervoltage Protection (UVLO)

TPS4800-Q1 has an accurate undervoltage protection ( $< \pm 2\%$ ) using EN/UVLO pin and an accurate overvoltage protection ( $< \pm 2\%$ ), providing robust load protection.  $\overline{FLT}$  is asserted when input undervoltage or overvoltage fault is detected. Connect a resistor ladder as shown in Figure 7-11 for undervoltage and overvoltage protection threshold programming.



**Figure 7-11. Programming Overvoltage and Undervoltage Protection Threshold**

### 7.3.5 Reverse Polarity Protection

The TPS48000-Q1 devices features integrated reverse polarity protection to protect the device from failing during input and output reverse polarity faults. Reverse polarity faults can occur during jump start, installation and maintenance of the end equipment's.

The device is tolerant to reverse polarity voltages down to -65V both on input and output.

On the output side, the device can see transient negative voltages during regular operation due to output cable harness inductance kickbacks when the switches are turned OFF. In such systems, the output negative voltage level is limited by the output side TVS or a diode.

### 7.3.6 Short-Circuit Protection Diagnosis (SCP\_TEST)

In the safety critical designs, short-circuit protection (SCP) feature and its diagnosis is important.

The TPS48000-Q1 features the diagnosis of the internal short circuit protection. When SCP\_TEST is driven low to high then, a voltage is applied internally across the SCP comparator inputs to simulate a short circuit event. The comparator output controls the gate drive (PU/PD) and also the  $\overline{\text{FLT}}$ . If the gate drive goes low (with initially being high) and  $\overline{\text{FLT}}$  also goes low then it indicates that the SCP is good otherwise it is to be treated as SCP feature is not functional.

If the SCP\_TEST feature is not used, then connect SCP\_TEST pin to GND.

### 7.3.7 TPS48000-Q1 as a Simple Gate Driver

Figure 7-12 shows application schematics of TPS48000-Q1 as a simple gate driver in load disconnect switch as well as back-to-back FETs driving topologies. The short-circuit protection feature is disabled.

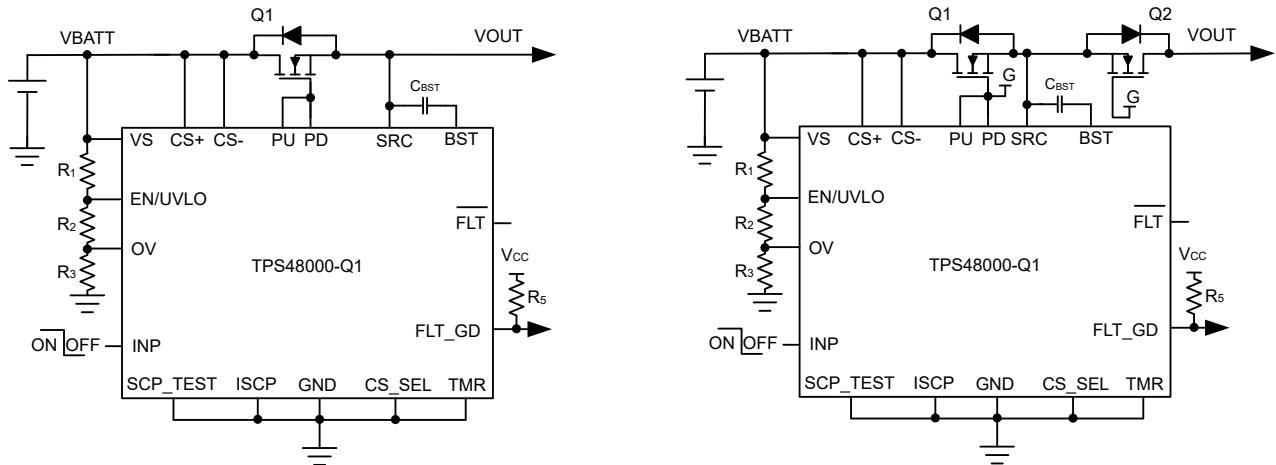

**Figure 7-12. TPS48000-Q1 Application Circuit for Simple Gate Driver Design**

### 7.4 Device Functional Modes

The TPS48000-Q1 has two modes of operation. Active mode and low IQ shutdown mode.

If the EN/UVLO pin voltage is greater than  $V_{(ENR)}$  rising threshold, then the device is in active mode. In active state the internal charge pump is enabled, gate drivers, all the protection and diagnostic features are enabled.

If the EN/UVLO voltage is pulled below  $V_{(ENF)}$  falling threshold, the device enters into low IQ shutdown mode. In this mode, the charge pump, gate drivers and all the protection features are disabled. The gate drive and external FETs turn OFF. The TPS48000-Q1 consumes low IQ of 1.5  $\mu\text{A}$  (typical) in this mode.

## 8 Application and Implementation

### Note

Information in the following applications sections is not part of the TI component specification, and TI does not warrant its accuracy or completeness. TI's customers are responsible for determining suitability of components for their purposes, as well as validating and testing their design implementation to confirm system functionality.

### 8.1 Application Information

The TPS48000-Q1 is a 100V low IQ smart high side driver with protection and diagnostics. With wide operating voltage range of 3.5 V–95V, the device is suitable for 12V, 24V and 48V system designs. The device can withstand and protect the loads from negative supply voltages down to –65V. It has strong 1.69A/2A peak source/sink gate driver enabling power switching using parallel FETs in high current system designs.

The device provides configurable short circuit protection using ISCP and TMR pins for adjusting the threshold and response time respectively. Auto-retry and latch-off fault behavior can be configured. With TPS48000-Q1, current sensing can be done either by an external sense resistor or by MOSFET VDS sensing. High or low side current sense resistor configuration is possible by using CS\_SEL pin input.

Diagnosis of the integrated short circuit comparator can be done using external control on SCP\_TEST input. The device indicates fault ( $\overline{\text{FLT}}$ ) on open drain output during during short circuit and input under voltage, overvoltage conditions. It also have a dedicate fault indication (FLT\_GD) to indicate the gate drive UVLO condition.

Low Quiescent Current 43 $\mu$ A operation enables always ON system designs. Quiescent current reduces to 1.5 $\mu$ A (typical) with EN/UVLO low.

### 8.2 Typical Application: Driving Power at all Times (PAAT) Loads

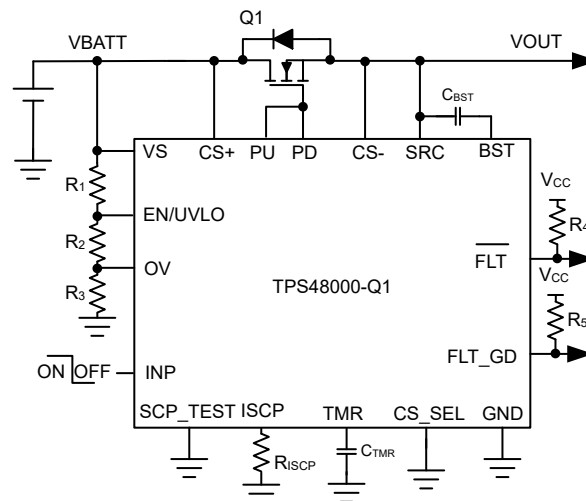

Figure 8-1. TPS48000-Q1 Application Circuit for driving PAAT loads with VDS based Current Sensing

#### 8.2.1 Design Requirements

**Table 8-1. Design Parameters**

PARAMETER	VALUE
Input Voltage Range, $V_{IN}$	16 to 60V
Undervoltage lockout set point, $V_{IN_{UVLO}}$	16V
Overshoot set point, $V_{IN_{OVP}}$	60V
Maximum load current, $I_{OUT}$	20A
Short-circuit protection threshold, $I_{SC}$	60A
Fault timer period, $t_{SC}$	50 $\mu$ s
Fault response	Auto-Retry
Current sensing	MOSFET VDS

## 8.2.2 Detailed Design Procedure

### Selection of MOSFET, Q<sub>1</sub>

For selecting the MOSFET Q<sub>1</sub>, important electrical parameters are the maximum continuous drain current I<sub>D</sub>, the maximum drain-to-source voltage V<sub>DS(MAX)</sub>, the maximum drain-to-source voltage V<sub>GS(MAX)</sub>, and the drain-to-source ON resistance R<sub>DS(ON)</sub>.

The maximum continuous drain current, I<sub>D</sub>, rating must exceed the maximum continuous load current.

The maximum drain-to-source voltage, V<sub>DS(MAX)</sub>, must be high enough to withstand the highest voltage seen in the application. Considering 60V as the maximum application voltage due to load dump, MOSFETs with V<sub>DS</sub> voltage rating of 80V is chosen for this application.

The maximum V<sub>GS</sub> TPS48000-Q1 can drive is 11V, so a MOSFET with 15V minimum V<sub>GS</sub> rating must be selected.

To reduce the MOSFET conduction losses, an appropriate R<sub>DS(ON)</sub> is preferred.

Based on the design requirements, IAUS200N08S5N023 is selected and its ratings are:

- 80V V<sub>DS(MAX)</sub> and ±20V V<sub>GS(MAX)</sub>
- R<sub>DS(ON)</sub> is 2.3mΩ typical at 10V V<sub>GS</sub>
- MOSFET Q<sub>g(total)</sub> is 85nC typical

TI recommends to make sure that the short-circuit conditions such max V<sub>IN</sub> and I<sub>SC</sub> are within SOA of selected FET (Q<sub>1</sub>) for at-least > t<sub>SC</sub> timing.

### Selection of Bootstrap Capacitor, C<sub>BST</sub>

The internal charge pump charges the external bootstrap capacitor (connected between BST and SRC pins) with approximately 345μA. Use the following equation to calculate the minimum required value of the bootstrap capacitor for driving IAUS200N08S5N023 MOSFET

$$C_{BST} = \frac{Q_{g(\text{total})}}{1V} = 85 \text{ nF} \quad (9)$$

Choose closest available standard value: 100nF, 10%.

### Programming the Short-Circuit Protection Threshold – R<sub>ISCP</sub> Selection

The R<sub>ISCP</sub> sets the short-circuit protection threshold, whose value can be calculated using below equation:

$$R_{ISCP} (\Omega) = \frac{(I_{SC} \times R_{DS\_ON} - 19 \text{ mV})}{2 \mu\text{A}} \quad (10)$$

To set 60 A as short-circuit protection threshold, R<sub>ISCP</sub> value is calculated to be 50.5kΩ.

Choose the closest available standard value: 51kΩ, 1%.

In case where large di/dt is involved, the system and layout parasitic inductances can generate large differential signal voltages between CS+ and CS– pins. This action can trigger false short-circuit protection and nuisance trips in the system. To overcome such scenario, TI suggests to add placeholder for RC filter components across sense resistor (R<sub>SNS</sub>) and tweak the values during test in the real system. The RC filter components should not be used in current sense designs by MOSFET V<sub>DS</sub> sensing to avoid impact on the short-circuit protection response.

### Programming the Fault timer Period – $C_{TMR}$ Selection

For the design example under discussion, overcurrent transients are allowed for 50 $\mu$ s duration. This blanking interval,  $t_{SC}$  (or circuit breaker interval,  $T_{CB}$ ) can be set by selecting appropriate capacitor  $C_{TMR}$  from TMR pin to ground. The value of  $C_{TMR}$  to set 50 $\mu$ s for  $t_{SC}$  can be calculated using following equation:

$$C_{TMR} = \frac{80 \mu A \times t_{SC}}{1.1} \quad (11)$$

Choose closest available standard value: 3.3nF, 10%.

### Setting the Undervoltage Lockout and Overvoltage Set Point

The undervoltage lockout (UVLO) and overvoltage set point are adjusted using an external voltage divider network of  $R_1$ ,  $R_2$  and  $R_3$  connected between VS, EN/UVLO, OV and GND pins of the device. The values required for setting the undervoltage and overvoltage are calculated by solving [Equation 12](#) and [Equation 13](#).

$$V_{(OVR)} = \frac{R_3}{(R_1 + R_2 + R_3)} \times V_{IN_{OVP}} \quad (12)$$

$$V_{(UVLOR)} = \frac{R_2 + R_3}{(R_1 + R_2 + R_3)} \times V_{IN_{UVLO}} \quad (13)$$

For minimizing the input current drawn from the power supply, TI recommends to use higher values of resistance for  $R_1$ ,  $R_2$  and  $R_3$ . However, leakage currents due to external active components connected to the resistor string can add error to these calculations. So, the resistor string current,  $I(R_{123})$  must be chosen to be 20 times greater than the leakage current of UVLO and OV pins.

From the device electrical specifications,  $V_{(OVR)} = 1.24V$  and  $V_{(UVLOR)} = 1.24V$ . From the design requirements,  $V_{IN_{OVP}}$  is 60V and  $V_{IN_{UVLO}}$  is 16V. To solve the equation, first choose the value of  $R_1 = 470k\Omega$  and use [Equation 12](#) to solve for  $(R_2 + R_3) = 39.5k\Omega$ . Use [Equation 13](#) and value of  $(R_2 + R_3)$  to solve for  $R_3 = 10.5k\Omega$  and finally  $R_2 = 29k\Omega$ . Choose the closest standard 1% resistor values:  $R_1 = 470k\Omega$ ,  $R_2 = 29.4k\Omega$ , and  $R_3 = 10k\Omega$ .

### 8.2.3 Application Curves

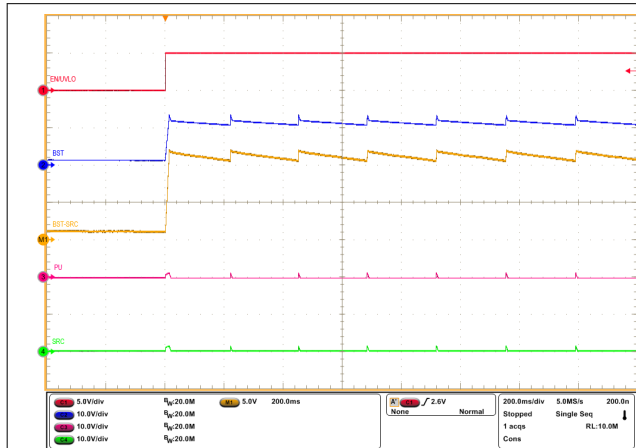

Figure 8-2. Start-Up Profile of Bootstrap Voltage with INP = GND and  $C_{BST} = 470nF$

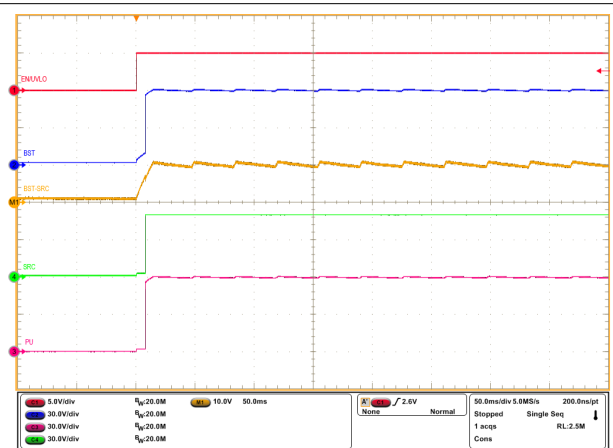

Figure 8-3. Start-Up Profile of Bootstrap Voltage with INP = HIGH and  $C_{BST} = 470nF$

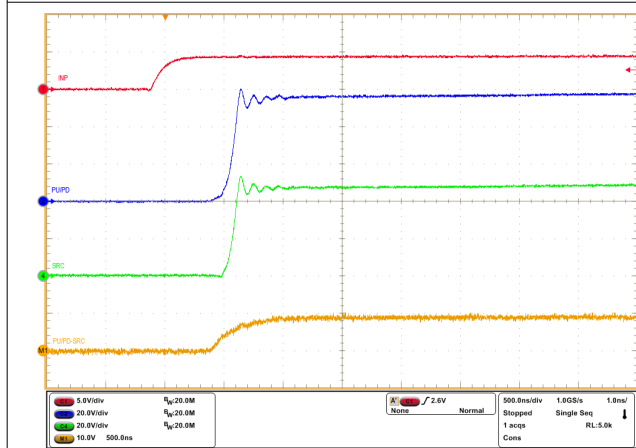

Figure 8-4. Turn-ON Response of TPS4800-Q1 for INP -> LOW to HIGH and  $C_{BST} = 470nF$

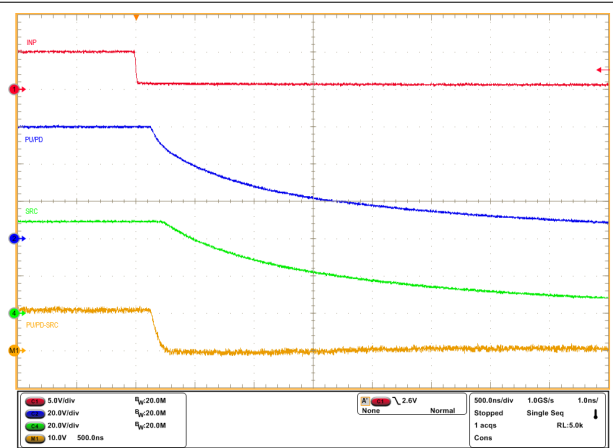

Figure 8-5. Turn-OFF Response of TPS4800-Q1 for INP -> HIGH to LOW and  $C_{BST} = 470nF$

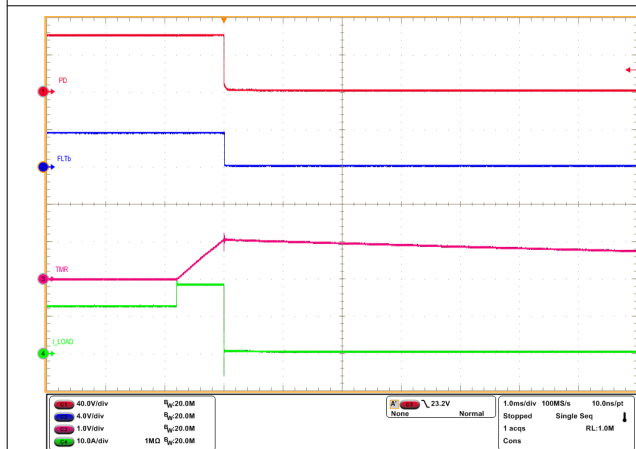

Figure 8-6. Overcurrent Response of TPS4800-Q1 for a Load Step from 12A to 18A with 15A Shortcircuit Protection Setting and  $t_{sc} = 1ms$

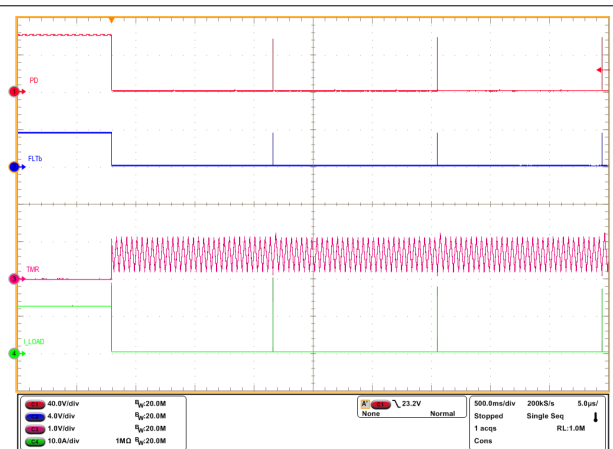
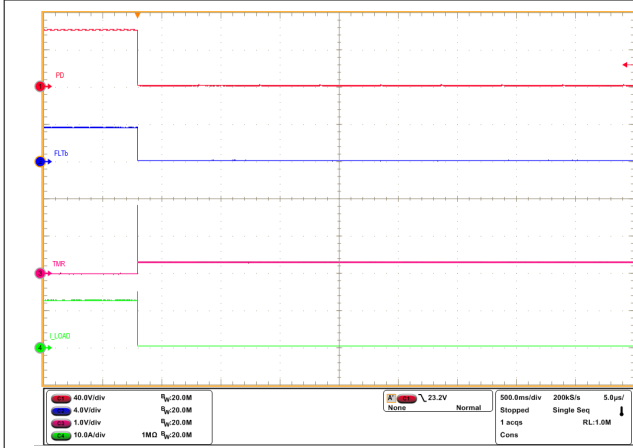
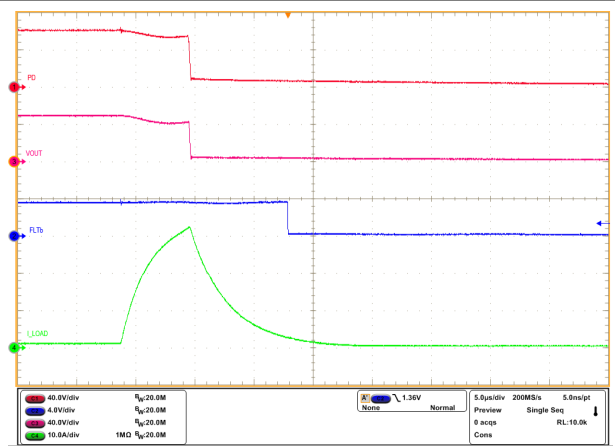

Figure 8-7. Auto-Retry Response of TPS4800-Q1 for an Overcurrent Fault



**Figure 8-8. Latch-Off Response of TPS4800-Q1 for an Overcurrent Fault**



**Figure 8-9. Output Short-Circuit Response of TPS4800-Q1 Device with 15A Shortcircuit Protection Setting and TMR = OPEN**

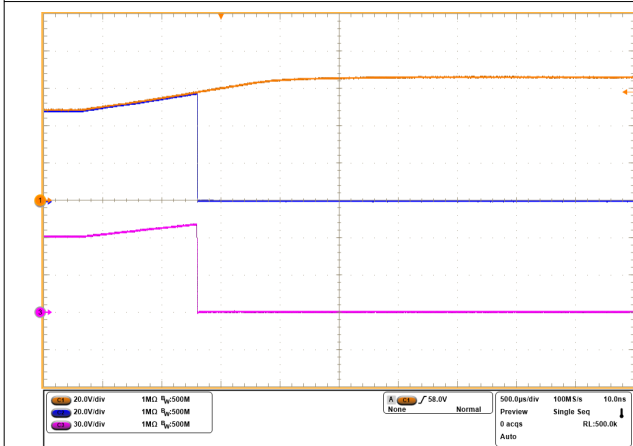

**Figure 8-10. Overvoltage Cutoff Response of TPS4800-Q1 at 58V Level**

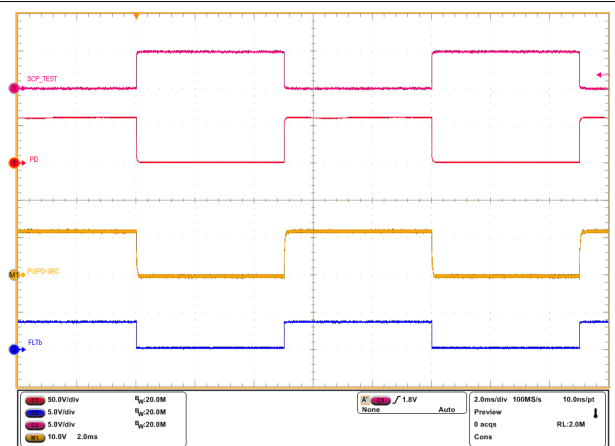

**Figure 8-11. Short-Circuit Protection Diagnosis Test Response of TPS4800-Q1**

### 8.3 Power Supply Recommendations

When the external MOSFETs turn-OFF during the conditions such as INP1 control, overcurrent protection causing an interruption of the current flow, the input parasitic line inductance generates a positive voltage spike on the input and output parasitic inductance generates a negative voltage spike on the output. The peak amplitude of voltage spikes (transients) depends on the value of inductance in series to the input or output of the device. These transients can exceed the *Absolute Maximum Ratings* of the device if steps are not taken to address the issue. Typical methods for addressing transients include:

- Use of a TVS diode and input capacitor filter combination across input to and GND to absorb the energy and dampen the positive transients.
- Use of a diode or a TVS diode across the output and GND to absorb negative spikes.

The TPS48000-Q1 gets powered from the VS pin. Voltage at this pin must be maintained above  $V_{(VS\_PORR)}$  level to ensure proper operation. If the input power supply source is noisy with transients, then TI recommends to place a  $R_{VS} - C_{VS}$  filter between the input supply line and VS pin to filter out the supply noise. TI recommends  $R_{VS}$  value around 100Ω.

In case where large  $di/dt$  is involved, the system and layout parasitic inductances can generate large differential signal voltages between CS+ and CS- pins. This action can trigger false short-circuit protection and nuisance trips in the system. To overcome such scenario, TI suggests to add placeholder for RC filter components across sense resistor ( $R_{SNS}$ ) and tweak the values during test in the real system. The RC filter components must not be used in current sense designs by MOSFET VDS sensing to avoid impact on the short-circuit protection response.

The following figure shows the circuit implementation with optional protection components.

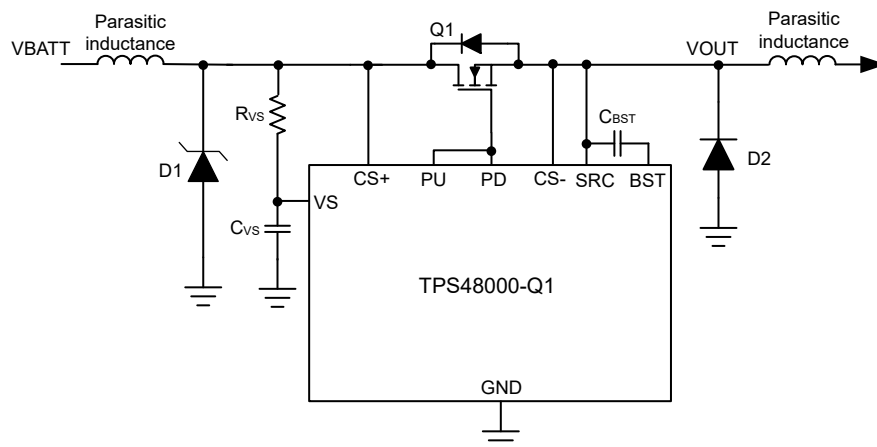

**Figure 8-12. Circuit Implementation With Optional Protection Components For TPS48000-Q1**

## 8.4 Layout

### 8.4.1 Layout Guidelines

- Place the sense resistor ( $R_{SNS}$ ) close to the TPS48000-Q1 and then connect  $R_{SNS}$  using the Kelvin techniques. Refer to [Choosing the Right Sense Resistor Layout](#) for more information on the Kelvin techniques.

For VDS based Current Sensing, follow the same kevin techniques across the MOSFET.

- Choose a 0.1  $\mu$ F or higher value ceramic decoupling capacitor between VS terminal and GND for all the applications. Consider adding RC network at the supply pin (VS) of the controller to improve decoupling against the power line disturbances.
- Make the high-current path from the board input to the load, and the return path, parallel and close to each other to minimize loop inductance.
- Place the external MOSFETs close to the controller GATE drive pins (PU/PD) such that the GATE of the MOSFETs are close to the controller GATE drive pins and forms a shorter GATE loop. Consider adding a place holder for a resistor in series with the Gate of each external MOSFET to damp high frequency oscillations if need arises.
- Place a TVS diode at the input to clamp the voltage transients during hot-plug and fast turn-off events.
- Place the external boot-strap capacitor close to BST and SRC pins to form very short loop.
- Connect the ground connections for the various components around the TPS48000-Q1 directly to each other, and to the TPS48000-Q1 GND, and then connected to the system ground at one point. Do not connect the various component grounds to each other through the high current ground line.

### 8.4.2 Layout Example

- Top Layer
- Inner Layer GND plane
- Inner Layer PGND plane
- Via to GND plane
- Via to PGND plane

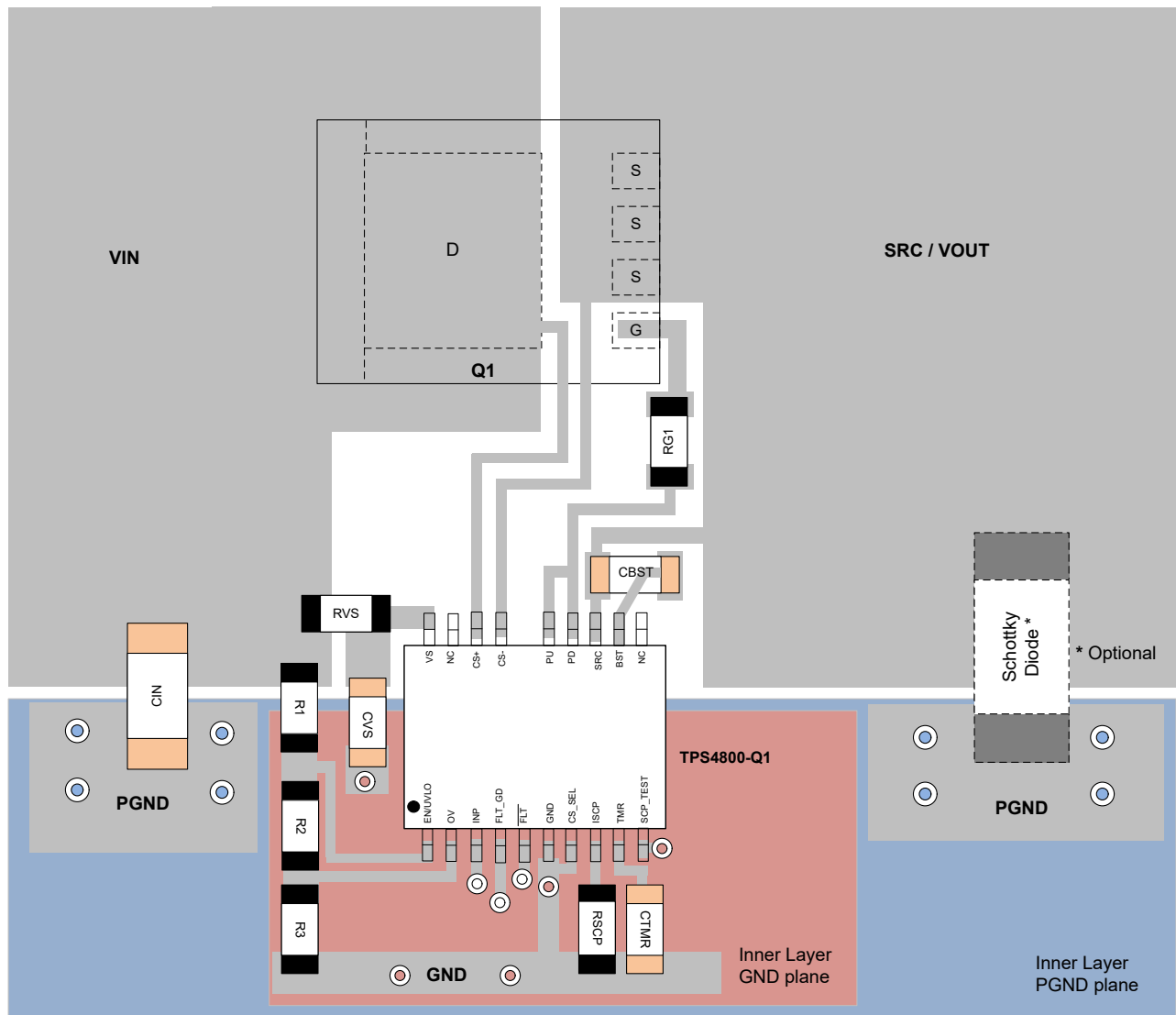

Figure 8-13. Typical PCB Layout Example for TPS4800-Q1 With VDS based Current Sensing

## 9 Device and Documentation Support

### 9.1 Receiving Notification of Documentation Updates

To receive notification of documentation updates, navigate to the device product folder on [ti.com](https://www.ti.com). Click on *Notifications* to register and receive a weekly digest of any product information that has changed. For change details, review the revision history included in any revised document.

### 9.2 Support Resources

[TI E2E™ support forums](#) are an engineer's go-to source for fast, verified answers and design help — straight from the experts. Search existing answers or ask your own question to get the quick design help you need.

Linked content is provided "AS IS" by the respective contributors. They do not constitute TI specifications and do not necessarily reflect TI's views; see TI's [Terms of Use](#).

### 9.3 Trademarks

TI E2E™ is a trademark of Texas Instruments.  
All trademarks are the property of their respective owners.

### 9.4 Electrostatic Discharge Caution



This integrated circuit can be damaged by ESD. Texas Instruments recommends that all integrated circuits be handled with appropriate precautions. Failure to observe proper handling and installation procedures can cause damage.

ESD damage can range from subtle performance degradation to complete device failure. Precision integrated circuits may be more susceptible to damage because very small parametric changes could cause the device not to meet its published specifications.

### 9.5 Glossary

[TI Glossary](#) This glossary lists and explains terms, acronyms, and definitions.

## 10 Revision History

NOTE: Page numbers for previous revisions may differ from page numbers in the current version.

<b>Changes from Revision * (December 2023) to Revision A (December 2024)</b>	<b>Page</b>
• Changed the document status From: <i>Advance Information</i> To: <i>Production Data</i> .....	<b>1</b>

## 11 Mechanical, Packaging, and Orderable Information

The following pages include mechanical, packaging, and orderable information. This information is the most current data available for the designated devices. This data is subject to change without notice and revision of this document. For browser-based versions of this data sheet, refer to the left-hand navigation.

**PACKAGING INFORMATION**

Orderable Device	Status (1)	Package Type	Package Drawing	Pins	Package Qty	Eco Plan (2)	Lead finish/ Ball material (6)	MSL Peak Temp (3)	Op Temp (°C)	Device Marking (4/5)	Samples
PTPS48000QDGXRQ1	ACTIVE	VSSOP	DGX	19	5000	TBD	Call TI	Call TI	-40 to 125		Samples
TPS48000QDGXRQ1	ACTIVE	VSSOP	DGX	19	5000	RoHS & Green	NIPDAU	Level-2-260C-1 YEAR	-40 to 125	4800	Samples

(1) The marketing status values are defined as follows:

**ACTIVE:** Product device recommended for new designs.

**LIFEBUY:** TI has announced that the device will be discontinued, and a lifetime-buy period is in effect.

**NRND:** Not recommended for new designs. Device is in production to support existing customers, but TI does not recommend using this part in a new design.

**PREVIEW:** Device has been announced but is not in production. Samples may or may not be available.

**OBsolete:** TI has discontinued the production of the device.

(2) **RoHS:** TI defines "RoHS" to mean semiconductor products that are compliant with the current EU RoHS requirements for all 10 RoHS substances, including the requirement that RoHS substance do not exceed 0.1% by weight in homogeneous materials. Where designed to be soldered at high temperatures, "RoHS" products are suitable for use in specified lead-free processes. TI may reference these types of products as "Pb-Free".

**RoHS Exempt:** TI defines "RoHS Exempt" to mean products that contain lead but are compliant with EU RoHS pursuant to a specific EU RoHS exemption.

**Green:** TI defines "Green" to mean the content of Chlorine (Cl) and Bromine (Br) based flame retardants meet JS709B low halogen requirements of <=1000ppm threshold. Antimony trioxide based flame retardants must also meet the <=1000ppm threshold requirement.

(3) MSL, Peak Temp. - The Moisture Sensitivity Level rating according to the JEDEC industry standard classifications, and peak solder temperature.

(4) There may be additional marking, which relates to the logo, the lot trace code information, or the environmental category on the device.

(5) Multiple Device Markings will be inside parentheses. Only one Device Marking contained in parentheses and separated by a "~" will appear on a device. If a line is indented then it is a continuation of the previous line and the two combined represent the entire Device Marking for that device.

(6) Lead finish/Ball material - Orderable Devices may have multiple material finish options. Finish options are separated by a vertical ruled line. Lead finish/Ball material values may wrap to two lines if the finish value exceeds the maximum column width.

**Important Information and Disclaimer:**The information provided on this page represents TI's knowledge and belief as of the date that it is provided. TI bases its knowledge and belief on information provided by third parties, and makes no representation or warranty as to the accuracy of such information. Efforts are underway to better integrate information from third parties. TI has taken and continues to take reasonable steps to provide representative and accurate information but may not have conducted destructive testing or chemical analysis on incoming materials and chemicals. TI and TI suppliers consider certain information to be proprietary, and thus CAS numbers and other limited information may not be available for release.

In no event shall TI's liability arising out of such information exceed the total purchase price of the TI part(s) at issue in this document sold by TI to Customer on an annual basis.



**TAPE AND REEL INFORMATION**

**QUADRANT ASSIGNMENTS FOR PIN 1 ORIENTATION IN TAPE**

\*All dimensions are nominal

Device	Package Type	Package Drawing	Pins	SPQ	Reel Diameter (mm)	Reel Width W1 (mm)	A0 (mm)	B0 (mm)	K0 (mm)	P1 (mm)	W (mm)	Pin1 Quadrant
TPS48000QDGXRQ1	VSSOP	DGX	19	5000	330.0	16.4	5.4	5.4	1.45	8.0	16.0	Q1

**TAPE AND REEL BOX DIMENSIONS**

\*All dimensions are nominal

Device	Package Type	Package Drawing	Pins	SPQ	Length (mm)	Width (mm)	Height (mm)
TPS48000QDGXRQ1	VSSOP	DGX	19	5000	353.0	353.0	32.0

# DGX0019A



# PACKAGE OUTLINE

## VSSOP - 1.1 mm max height

SMALL OUTLINE PACKAGE

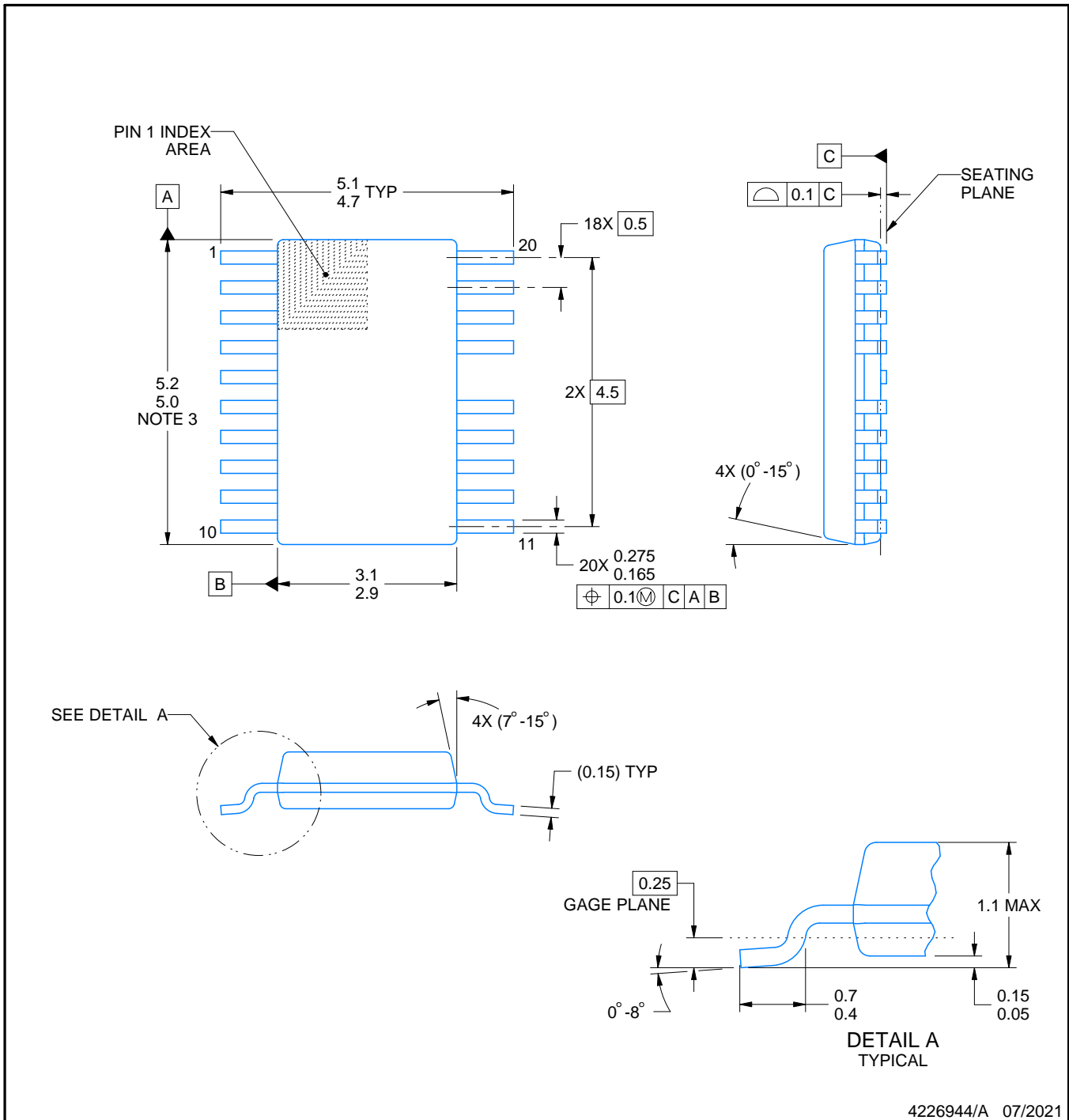

4226944/A 07/2021

**NOTES:**

PowerPAD is a trademark of Texas Instruments.

1. All linear dimensions are in millimeters. Any dimensions in parenthesis are for reference only. Dimensioning and tolerancing per ASME Y14.5M.
2. This drawing is subject to change without notice.
3. This dimension does not include mold flash, protrusions, or gate burrs. Mold flash, protrusions, or gate burrs shall not exceed 0.15 mm per side.
4. No JEDEC registration as of July 2021.
5. Features may differ or may not be present.

# EXAMPLE BOARD LAYOUT

DGX0019A

VSSOP - 1.1 mm max height

SMALL OUTLINE PACKAGE

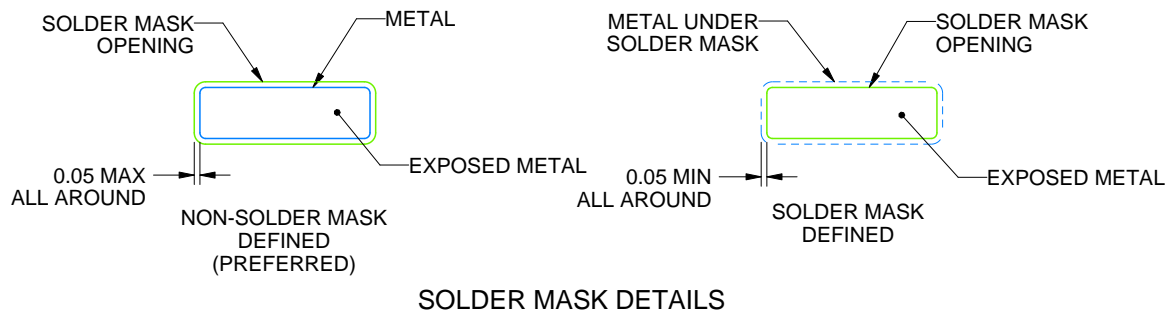
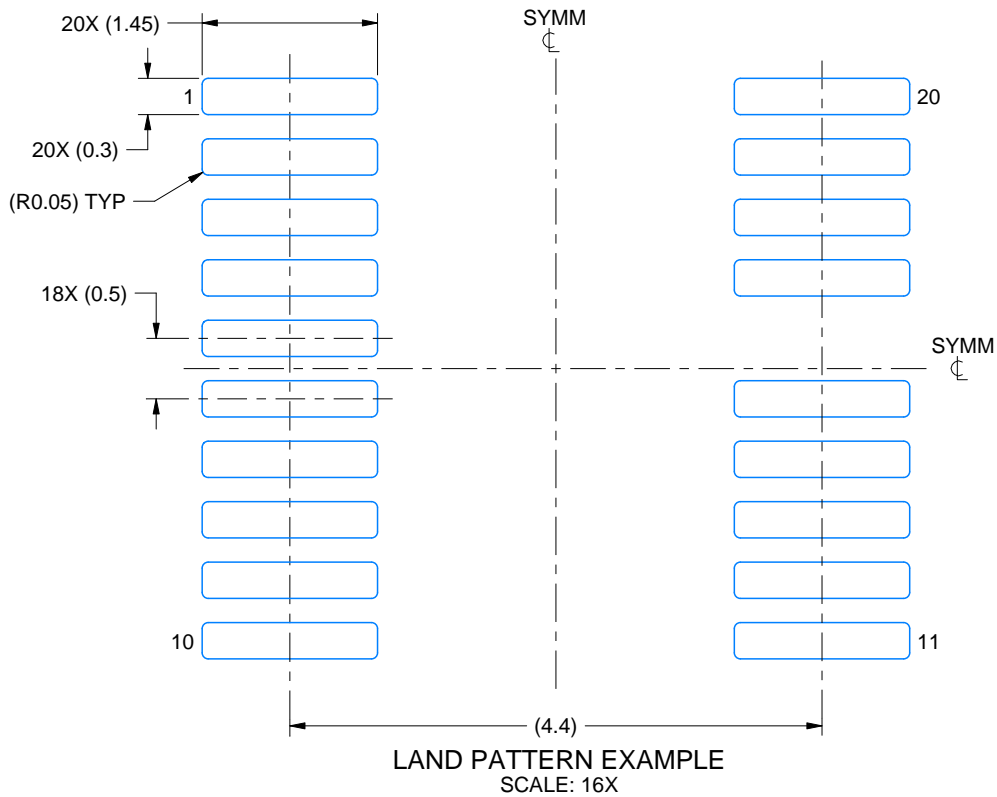

4226944/A 07/2021

NOTES: (continued)

6. Publication IPC-7351 may have alternate designs.
7. Solder mask tolerances between and around signal pads can vary based on board fabrication site.
8. This package is designed to be soldered to a thermal pad on the board. For more information, see Texas Instruments literature numbers SLMA002 ([www.ti.com/lit/slma002](http://www.ti.com/lit/slma002)) and SLMA004 ([www.ti.com/lit/slma004](http://www.ti.com/lit/slma004)).
9. Size of metal pad may vary due to creepage requirement.
10. Vias are optional depending on application, refer to device data sheet. It is recommended that vias under paste be filled, plugged or tented.

# EXAMPLE STENCIL DESIGN

DGX0019A

VSSOP - 1.1 mm max height

SMALL OUTLINE PACKAGE

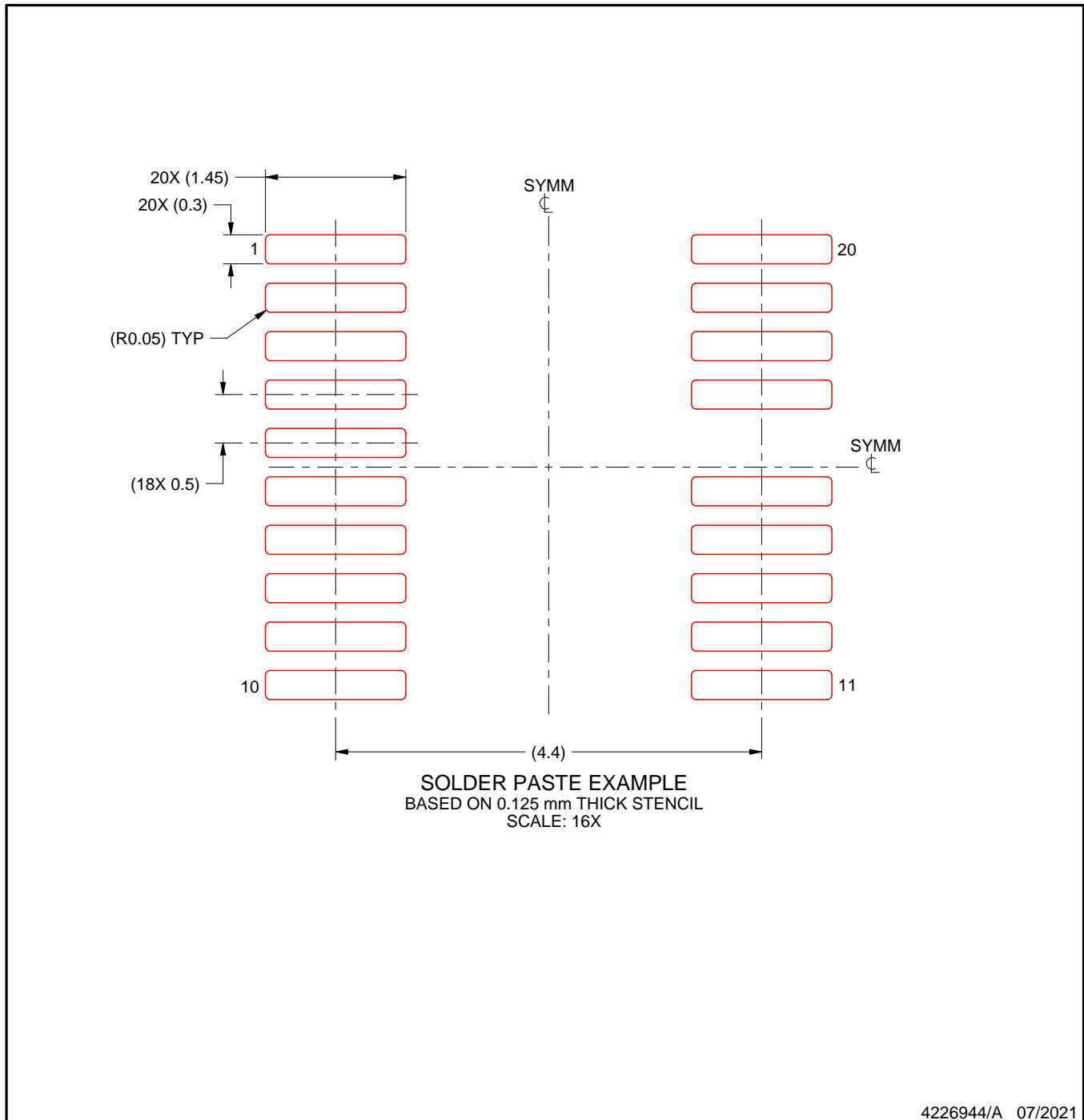

NOTES: (continued)

11. Laser cutting apertures with trapezoidal walls and rounded corners may offer better paste release. IPC-7525 may have alternate design recommendations.
12. Board assembly site may have different recommendations for stencil design.

## IMPORTANT NOTICE AND DISCLAIMER

TI PROVIDES TECHNICAL AND RELIABILITY DATA (INCLUDING DATA SHEETS), DESIGN RESOURCES (INCLUDING REFERENCE DESIGNS), APPLICATION OR OTHER DESIGN ADVICE, WEB TOOLS, SAFETY INFORMATION, AND OTHER RESOURCES "AS IS" AND WITH ALL FAULTS, AND DISCLAIMS ALL WARRANTIES, EXPRESS AND IMPLIED, INCLUDING WITHOUT LIMITATION ANY IMPLIED WARRANTIES OF MERCHANTABILITY, FITNESS FOR A PARTICULAR PURPOSE OR NON-INFRINGEMENT OF THIRD PARTY INTELLECTUAL PROPERTY RIGHTS.

These resources are intended for skilled developers designing with TI products. You are solely responsible for (1) selecting the appropriate TI products for your application, (2) designing, validating and testing your application, and (3) ensuring your application meets applicable standards, and any other safety, security, regulatory or other requirements.

These resources are subject to change without notice. TI grants you permission to use these resources only for development of an application that uses the TI products described in the resource. Other reproduction and display of these resources is prohibited. No license is granted to any other TI intellectual property right or to any third party intellectual property right. TI disclaims responsibility for, and you will fully indemnify TI and its representatives against, any claims, damages, costs, losses, and liabilities arising out of your use of these resources.

TI's products are provided subject to [TI's Terms of Sale](#) or other applicable terms available either on [ti.com](https://www.ti.com) or provided in conjunction with such TI products. TI's provision of these resources does not expand or otherwise alter TI's applicable warranties or warranty disclaimers for TI products.

TI objects to and rejects any additional or different terms you may have proposed.

Mailing Address: Texas Instruments, Post Office Box 655303, Dallas, Texas 75265  
Copyright © 2024, Texas Instruments Incorporated

## Looking for pricing, stock, or lifecycle information?

Click below to explore more details on WIN SOURCE:

 [View PTPS48000QDGXRQ1 on WIN SOURCE](#)

 [Texas Instruments](#) Information

## Optimize Your Supply Chain with WIN SOURCE Solutions

-  Global Sourcing Solution
-  Obsolete Management
-  Cost Control Management
-  Shortage Management
-  Alternative Solution
-  Excess Inventory Management