

C2000™ Piccolo™ F28004x Series LaunchPad™ Development Kit

The C2000 LAUNCHXL-F280049C is a low-cost development board for the Texas Instruments Piccolo F28004x series of microcontrollers (MCUs). It is designed around the TMS320F280049C MCU and highlights the control, analog, and communications peripherals, as well as the integrated nonvolatile memory. The LaunchPad also features two independent BoosterPack XL expansion connectors, on-board Controller Area Network (CAN) transceiver, 5 V encoder connectors, FSI connector, and an on-board XDS110 debug probe.

Figure 1 highlights the key features of the Piccolo F28004x LaunchPad.

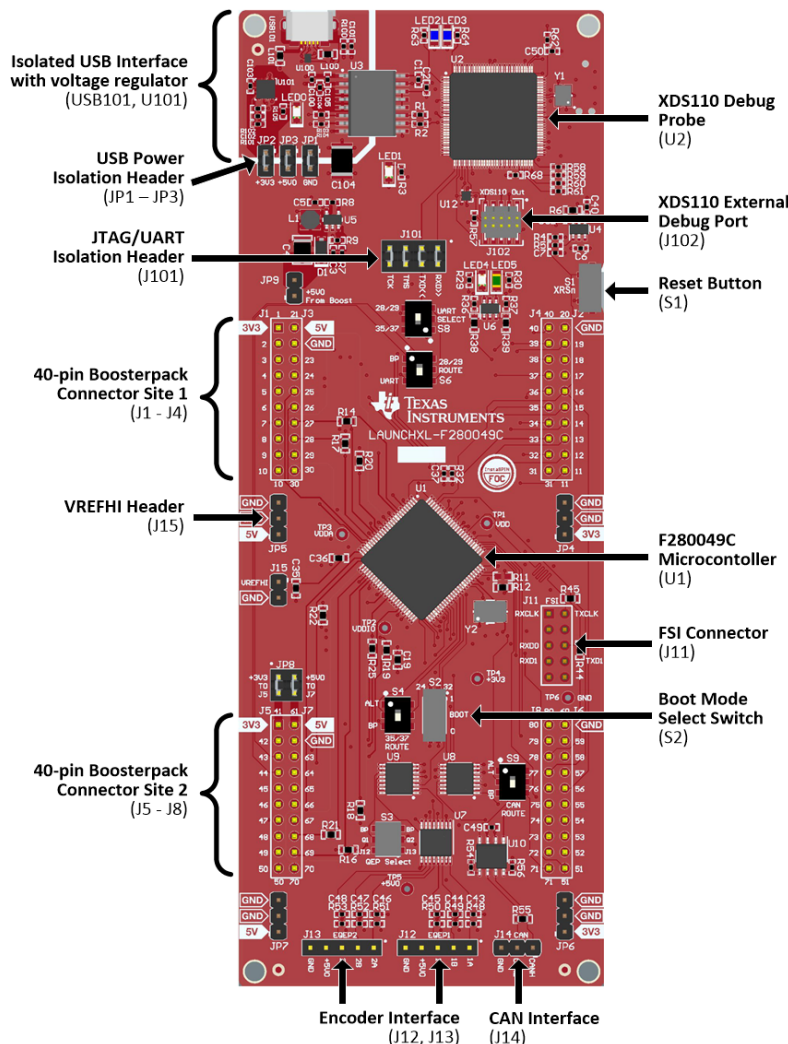

Figure 1. Piccolo F28004x Series LaunchPad Development Kit

Contents

1	Board Overview	3
2	Hardware Description	6
3	Software Development	12
4	Board Design	14
5	References	23
Appendix A	24

List of Figures

1	Piccolo F28004x Series LaunchPad Development Kit.....	1
2	Piccolo F28004x LaunchPad Development Kit Block Diagram.....	6
3	BoosterPack Pin Map	8
4	MCU025B_Block_Diagram.SchDoc	14
5	MCU025B_Connectors.SchDoc.....	15
6	MCU025B_AltRouting_Misc.SchDoc	16
7	MCU025B_F280049C_Device.SchDoc	17
8	MCU025B_XDS110_Target_Interface.SchDoc	18
9	MCU025B_XDS110_USB_Power.SchDoc	19
10	MCU025B_XDS110_MCU.SchDoc.....	20
11	MCU025B_Hardware.SchDoc.....	21
12	F28004x LaunchPad Dimensions and Component Locations	22
13	Target Configuration Advanced Options	25
14	Target Configuration included in the demo project	25

List of Tables

1	LAUNCHXL-F280049C Specifications.....	3
2	Boot Select Switch Settings	7
3	PGA Signals and Associated Connections	10
4	Alternate Function Switch Settings	11
5	FSI to BoosterPack Isolation Resistors	12

Trademarks

C2000, Piccolo, LaunchPad, InstaSPIN-FOC, InstaPIN-FOC, FAST, Code Composer Studio are trademarks of Texas Instruments.

All other trademarks are the property of their respective owners.

1 Board Overview

1.1 Kit Contents

The Piccolo F28004x Series LaunchPad Development Kit contains these items:

- C2000 Piccolo F28004x Series LaunchPad development board (LAUNCHXL-F280049C)
- USB micro-B plug to USB-A plug cable
- Two LaunchPad Stickers

1.2 Features

The F28004x LaunchPad has these features:

- C2000 Piccolo Series F280049CPZS microcontroller:
 - Enabled for InstaSPIN-FOC™ motor control and Configurable Logic Block (CLB) capability
- On-board XDS110 debug probe
- Two user-controlled LEDs
- One microcontroller reset switch
- Selectable power domains:
 - USB (isolated)
 - BoosterPack
 - External power supply
- CAN connectivity with on-board CAN transceiver
- Two independent Enhanced Quadrature Encoder Pulse (QEP)-based encoder connectors
- Separate FSI connector
- Two independent BoosterPack XL standard connectors featuring stackable headers to maximize expansion through the BoosterPack ecosystem

1.3 Specifications

[Table 1](#) summarizes the F28004x LaunchPad specifications.

Table 1. LAUNCHXL-F280049C Specifications

Parameter	Value
Board Supply Voltage	5 V _{DC} from one of the following sources: <ul style="list-style-type: none"> • Debug USB (USB101) USB Micro-B cable connected to PC or other compatible power source. • BoosterPack 1 • BoosterPack 2 • Auxiliary power connectors
Dimensions	6.15 in x 2.3 in x .425 in (15.62 cm x 5.84 cm x 10.8 mm) (L x W x H)
Break-out Power Output	<ul style="list-style-type: none"> • Optional 5 V_{DC} to BoosterPacks, current limited by LMR62421. Nominal rating 2.1 Amps. Board input power supply limitations may also apply. • 3.3 V_{DC} to BoosterPacks, limited by output of TPS79601 LDO. This 3.3-V plane is shared with on-board components. Total output power limit of TPS79601 is 1 Amp.
Assumed Operating Conditions	This kit is assumed to run at standard room conditions. The EVM should run at approximately standard ambient temperature and pressure (SATP) with moderate-to-low humidity.

1.4 Using the F28004x LaunchPad

The recommended steps for using the F28004x LaunchPad are:

1. **Follow the README First document included in the kit.** The README First document helps you run the LaunchPad. Within just a few minutes, you can control and monitor the F28004x LaunchPad with the pre-programmed quick start application. Additionally, [Section A.1](#), the FAQ section included in this document can be helpful if there are any issues that might quickly be addressed.
2. **Experiment with BoosterPacks.** This development kit conforms to the latest revision of the BoosterPack pinout standard. It has two independent BoosterPack connections to enable a variety of expansion opportunities. For more information about the TI LaunchPad and BoosterPack standard, see the TI LaunchPad web page at <http://www.ti.com/launchpad>.
3. **Take the first step towards developing your own control applications.** The F28004x LaunchPad is supported by the [C2000Ware](#) development package. After C2000Ware is installed, look for `f28004x\examples\launchpad` in the installation directory. You can find pre-configured example applications for this board as well as for this board with selected BoosterPacks. Any of the other examples found within the `f28004x\examples` directory can be used with minor modifications to run on the LaunchPad as well. For more details about software development, see [Section 3](#).
4. **Customize and integrate the hardware to suit your end application.** This development kit can be used as a reference for building your own custom circuits based on C2000 Piccolo Series microcontrollers or as a foundation for expansion with your custom BoosterPack or other circuits. This document can serve as a starting point for this endeavor.
5. **Get Trained.** You can also download hours of written and video training materials on this and related LaunchPads. For more information, visit the [C2000 Real-Time Control MCUs - Support & Training](#) page.

1.5 BoosterPacks

The LAUNCHXL-F280049C provides an easy and inexpensive way to develop applications with the F28004x Series microcontroller. BoosterPacks are add-on boards that follow a pin-out standard created by Texas Instruments. The TI and third-party ecosystem of BoosterPacks greatly expands the peripherals and potential applications that you can easily explore with the F28004x LaunchPad.

You can also build your own BoosterPack by following the design guidelines on TI's website. Texas Instruments even helps you promote your BoosterPack to other members of the community. TI offers a variety of avenues for you to reach potential customers with your solutions.

1.6 InstaPIN-FOC™

The LAUNCHXL-F280049C includes the Piccolo TMS320F280049C that has the superset configuration of features enabled, including InstaSPIN-FOC sensorless motor control technology. A library is included in on-chip ROM that can be accessed by a set of software APIs as demonstrated by projects included in C2000Ware MotorControl Software Development Kit (available 2018Q4).

[InstaSPIN-FOC](#) technology identifies motor parameters, self-tunes the sensorless [FAST™ observer](#), sets stable tuning for the current controllers, and allows you to quickly control your own three-phase motors under advanced, high-performance field oriented vector control (FOC) without the need for mechanical rotor sensors.

1.7 Hardware Revisions

This section contains an abbreviated revision history of the EVM as well as known issues with each revision.

1.7.1 Revision A

The first production revision of the LAUNCHXL-F280049C was released in July 2018. This revision can be identified by the "MCU025A" silkscreen labeling on the back side of the EVM between the BoosterPack Connector site 1 towards the top of the board.

Various issues and concerns have been Identified on the EVM as listed below:

Known issues:

- There is contention on the primary side power of the USB Isolation IC, ADUM3160 (U3). As VBUS1 is connected to a 5 V supply (USB_VBUS), the internal regulator of the ADUM3160 will provide 3.3 V internally, with the VDD1 pin being an output. In this revision, USB_VCC, a 3.3 V supply, is connected to VDD1 leading to the contention. Any fluctuation of either 3.3 V supply (USB_VCC and ADUM3160 VDD1) may cause currents to be sourced or drawn from either supply. This is a long term reliability concern for both U3 and U101.
- On the PCB, the J6 and J8 labeling is swapped on the silkscreen. J6 is marked as the inner row (pins 71-80) and J8 is marked as the outer row (pins 51-60). This is incorrect and J6 should be on the outer row with (pins 51-60) and J8 is the inner row (pins 71-80).
- Similar to the above, on the MCU025A_Connectors.SchDoc, J6 and J8 should be swapped. In the schematic symbol J8 should be above Pins 31-40, while J6 should be above pins 11-20.
- Similar to the PCB silkscreen and the schematic, the Quick Start Guide insert has the pin numbers for 51-60 listed as J8 and 71-80 listed as J6. This is incorrect; the pin numbers should be swapped.

Special notes and considerations to be aware of:

- A precision reference (U11) is connected to VREF+ (pin 9) of the TM4C129x device (U2 - the XDS110 MCU). This is not necessary for the operation of the debug probe. VREF+ (pin 9) can be safely connected directly to VDDA (pin 8). There are no issues with the current configuration; it is an opportunity for BOM cost/simplification for those seeking to replicate this design on their own.
- The EMU package 8.0.903.4 has a firmware update for the XDS110 Debug probe. This update breaks the cJTAG function of the XDS110. Refer to [Section A.1](#), the FAQs, for more information on how to resolve this issue if encountered.

1.7.2 Revision B

The second production revision of the LAUNCHXL-F280049C was released in x. This revision can be identified by the "MCU025B" silkscreen labeling on the back side of the EVM. The fixed issues and added enhancements from the first revision (A) are described below.

Fixed issues:

- Fixed primary side power contention issue on USB Isolation IC, ADUM3160 (U3). See [Section 1.7.1](#) for description of issue.
- Fixed J6 and J8 header errors described in [Section 1.7.1](#)

Enhancements:

- FSITXD1, FSIRXD1, and 3.3V power signals have been added to the expanded 2x5 connector J11
- XDS110 MCU (U2) TM4C129x device replaced with MSP432E401 device. Form and function have not been changed with this in any way.
- Precision reference (U11) connected to the XDS110 MCU (U2) has been removed and VREF+ (pin 9) has been directly connected to VDDA (pin 8)

2 Hardware Description

The F28004x LaunchPad includes a F280049CPZS MCU. This MCU is well suited for advanced real-time control systems in cost-sensitive applications. A large number of these peripherals are made available to users via the on-board accessories and the BoosterPack connectors. This section explains how those peripherals operate and interface to the MCU.

Figure 2 shows a high-level block diagram of the F28004x LaunchPad:

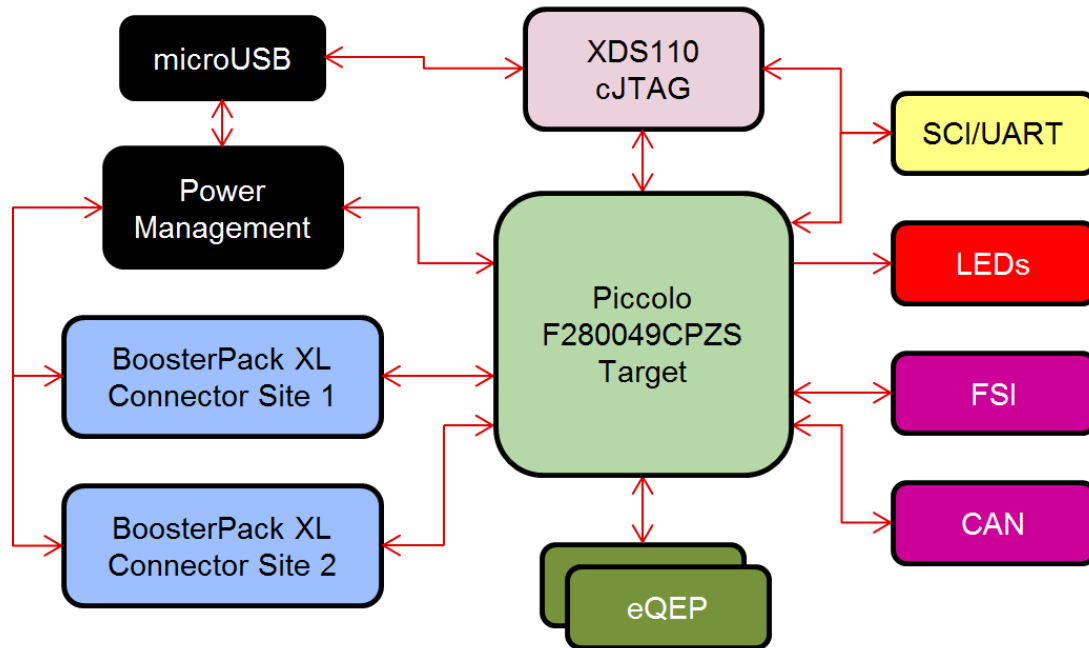

Figure 2. Piccolo F28004x LaunchPad Development Kit Block Diagram

2.1 Functional Description and Connections

2.1.1 Microcontroller

The F280049CPZS is a 32-bit floating-point microcontroller with 256KB Flash memory, 100KB RAM, and operates at 100 MHz. It includes advanced control peripherals, differentiated analog, and various communications peripherals. The device has been optimized for high-performance applications and provides a low-cost system solution. For more details, see the [TMS320F28004x Piccolo microcontrollers data sheet](#).

Most of the microcontroller's signals are routed to 0.1 inch (2.54 mm) pitch headers laid out to comply with the TI BoosterPack standards with a few exceptions. An internal multiplexer allows different peripheral functions to be assigned to each of the General-Purpose Input/Output (GPIO) pads. The multiplexing options can be found in the device-specific data sheet. When adding external circuitry, consider the additional load on the development board power rails.

The F28004x LaunchPad is factory-programmed with a quick start demo program. The quick start program resides in the on-chip Flash memory and executes each time power is applied, unless the application has been replaced with a user program. The quick start application utilizes the integrated Analog-to-Digital Converter (ADC) module to sample the voltage on a pin, then output the results with the Serial Communications Interface (SCI) Universal Asynchronous Receiver/Transmitter (UART) through the Virtual COM port (VCP) of the XDS110 debug probe to a PC with a serial monitor running.

2.1.2 LEDs

Two power indicator LEDs are included on the board: LED0 indicates when the 3.3 V is available on the USB side of the isolation barrier and LED1 indicates when 3.3 V is available on the device side of the isolation. LED1 indicates that there is power supplied to the F28004x device as well as the XDS110 debugger.

Two user LEDs are provided on the board: LED4 (red) and LED5 (green). These user LEDs are connected to GPIO23 and GPIO34, respectively. These are connected to the SN74LVC2G07DBVR LED driver IC and are connected in an active low configuration; that is, drive the GPIO low to turn on the LED and high to turn it off. These LEDs are dedicated for use by the software application.

Two blue LEDs, LED2 and LED3, are connected to the XDS110 debug probe. These indicate debugger activity and are not controllable by any application software.

2.1.3 Encoder Connectors

The F28004x LaunchPad includes two headers, J12 and J13, which are used for connecting linear or rotary incremental encoders. These headers take 5 V signals that are down-converted to 3.3 V and wired to the F280049C MCU. These signals are connected to the eQEP modules on the device. Each header has the EQEPA, EQEPB, and EQEPI signals available for each eQEP module as well as pins for GND and 5 V.

2.1.4 FSI

The F28004x MCU features the industry first Fast Serial Interface (FSI). The FSI enables robust high-speed communications and is intended to increase the amount of information transmitted while reducing the costs to communicate over an isolation barrier. Though no isolator is included on this LaunchPad, the TXCLK, TXD0, TXD1, RXCLK, RXD0, and RXD1 signals are available on J11. This header is set up in such a way that adding jumpers on the pins will connect the TX to RX channels for external loopback and evaluation. Additionally, there are two GND signals on the connector that can be used for a wrapped-pair connection to an external board with FSI. The GPIOs connected to this header are also routed to the BoosterPack connectors through 0Ω resistors. As the FSI can toggle at up to 100 MHz rates, the longer traces to the BoosterPack headers can create unintentional noise on the signal due to reflection. Eliminating these extended traces by removing the in-circuit resistors will help to limit any noise or reflections.

2.1.5 CAN

The F28004x LaunchPad includes a connector for a CAN network through J14. GPIO32 and GPIO33 are routed from the F280049CPZS to J14 through the on-board CAN Transceiver. GPIO33 is also wired to the FSI connector.

2.1.6 Boot Modes

The F280049C boot ROM contains bootloading software that executes every time the device is powered on or reset. Two pins, GPIO24 and GPIO32, are wired to the Boot Select switch (S2). Note that S2 is placed upside down, so the OFF (open) position corresponds to a logic 1 and the ON (closed) position corresponds to 0. By default, both pins are set to the OFF position so the device will boot from Flash. For more information on the F28004x boot modes, see the [TMS320F28004x Piccolo microcontrollers data sheet](#).

Table 2. Boot Select Switch Settings

BOOT MODE	GPIO32 (Position 1)	GPIO24 (Position 2)
Boot from Parallel GPIO	ON (0)	ON (0)
Boot from SCI / Wait boot	OFF (1)	ON (0)
Boot from CAN	ON (0)	OFF (1)
Boot from Flash (default)	OFF (1)	OFF (1)

2.1.7 BoosterPack Headers

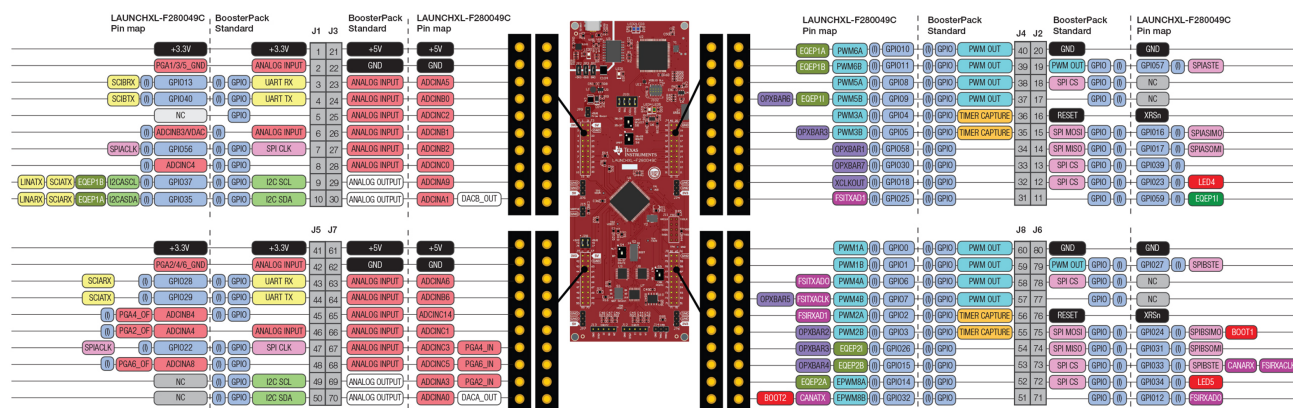

Figure 3. BoosterPack Pin Map

2.1.7.1 BoosterPack Sites

The F28004x LaunchPad features two fully independent BoosterPack XL connectors. BoosterPack site #1, located above the F28004x MCU and below the XDS110 debugger, is compliant with the BoosterPack standard with a few exceptions as noted in [Figure 3](#). BoosterPack site #2, located under the F28004x MCU, is compliant with the BoosterPack standard with a few exceptions as well, noted in [Figure 3](#). To expand the functions available to the user on this LaunchPad, some signals are also routed to alternate locations on the board. These alternate routes can be selected by manipulating the onboard switches or adding or removing 0 Ω resistors. This is described in [Section 2.3](#).

The GPIO pin number as well as the BoosterPack compliant features are listed in [Figure 3](#). Each GPIO has multiple functions available through the GPIO mux. A few special functions have also been listed above; the full GPIO mux table can be found in the [TMS320F28004x Piccolo microcontrollers data sheet](#).

2.1.8 Analog Voltage Reference Header

The analog subsystem of the F28004x allows for flexible voltage reference sources. The ADC and DAC modules are referenced to the VREFH1x and VREFLOx pin voltages. VREFH1x can either be driven externally or can be generated by an internal bandgap voltage reference. An external voltage can be supplied to header J15 as an external voltage source for VREFH1x. Note that there is no signal conditioning circuitry in place for the voltage reference. For best performance, some additional circuitry may be required.

2.1.9 Other Headers and Jumpers

The Piccolo LaunchPad has multiple jumpers to select different power sources for the board. This LaunchPad also provides a way to isolate the connected USB from the device, allowing for safe operation and debugging in high-voltage applications.

2.1.9.1 USB Isolation Block

JP1, JP2, and JP3 are provided to enable isolation between the device and the connected USB in high-voltage applications. The area of isolation is defined by the white outline in the upper-left corner of the LaunchPad. JP1 separates the GND of USB region and the MCU region of the LaunchPad. JP2 separates 3.3 V, and JP3 separates 5 V. By default, all three jumpers are shorted and the power is supplied by the connected USB, meaning that the USB is NOT isolated from the MCU region. If power isolation is desired, remove the supplied shunts from JP1, JP2, and JP3. In this configuration, a 3.3 V supply must be connected to the MCU region to power the F280049C MCU and the other on-board circuitry, including the XDS110 debug probe. Some applications may not require 5 V to be supplied to the MCU region. In an isolated power application with JP3 removed, supplying 5 V to the MCU region is optional.

2.1.9.2 BoosterPack Site 2 Power Isolation

JP8 is included to isolate 3.3 V and 5 V from the BoosterPack 2 headers. This might be required if two BoosterPacks are simultaneously connected to the LaunchPad and both provide power to the LaunchPad. If this is the case, power can be isolated by removing the shunts on JP8 and there will be no contention between the two BoosterPacks.

2.1.9.3 Alternate Power

Additional jumpers are provided outside of the BoosterPack connector for additional external power connections for 3.3 V or 5 V. These can be used to supply an external board or for powering the LaunchPad with an external supply. When using these connection points, ensure that no other power supplies are connected.

JP4 and JP6 are provided as extra connection points for a 3.3 V supply to be connected to the LaunchPad.

JP5 and JP7 are provided as extra connection points for a 5 V supply to be connected to the LaunchPad.

2.1.9.4 5 V Step-up Converter

JP9 isolates the output of the LMR2421 Simple Switcher step-up voltage regulator(U3) from the 5 V power domain of the LaunchPad. This voltage regulator can step up 3.3 V to 5 V if no other 5 V supply is connected. Do not place a shunt on J9 unless JP3 is open and no other 5 V supply is connected to the LaunchPad.

2.1.10 PGA

The F28004x MCU features on-chip Programmable Gain Amplifiers (PGA) to amplify an input voltage for increasing the dynamic range of the downstream ADC and CMPSS modules. The integrated PGA helps to reduce the cost and design effort for many control applications that traditionally require external, stand-alone amplifiers. On-chip integration ensures that the PGA is compatible with the downstream ADC and CMPSS modules. Software selectable gain and filter settings make the PGA adaptable to various performance needs. For more information on the PGAs, see the device-specific data sheet and TRM.

The F28004x LaunchPad was designed to optimize the routing of certain PGA signals to the BoosterPack connectors. This design choice allows for the evaluation of the on-chip PGA, if desired. Three PGA modules are routed each BoosterPack Connector. An RC filter can be placed on each of these signals to provide additional filtering of the input signal. By default, 0 Ω series resistor and pads for a decoupling capacitor are placed on each PGA input signal. These values can be modified based on application requirements.

In addition to the PGA input signals, BoosterPack site 2 has the associated output filter signals routed. Each output filter signal has two components: a 0 Ω series resistor and a decoupling capacitor. If the PGA output filters are used, remove the 0 Ω series resistor to isolate it from the BoosterPack connector, and place an appropriate filter capacitor. By default, a 330 pF capacitor is populated. An isolated ground plane for the PGAs has been created to help limit outside noise coupling onto the PGA signals. By default, this ground plane is shorted to the ground plane of the PCB through a resistor. If isolation between PGAx_GND and the PCB ground is needed the resistor can be removed.

Wherever a PGA signal is brought to the BoosterPack connector, an ADC input is also provided. Depending on the signal, the ADC is connected by either a short on the board or through on-chip connections. Other than PGA4_IN and PGA6_IN, each PGA input signal can be isolated from the connected ADC signal by removing the 0 Ω resistor that is part of the input RC filter.

[Table 3](#) summarizes the available PGA signals and connections. For the full connection details, see Sheet 4 of the board schematic.

Table 3. PGA Signals and Associated Connections

BoosterPack Site	Pin Position	PGA Signal	ADC Input Signal	Note
1	J3.27	PGA1_IN	ADCINB2	Populate RC filter if required
	J3.28	PGA3_IN	ADCINC0	Populate RC filter if required
	J3.29	PGA5_IN	ADCINA9	Populate RC filter if required
	J1.2	PGA1/3/5_GND	–	Connected to PCB GND by default. Remove R26 is PGA_GND isolation is required
2	J7.29 (69)	PGA2_IN	ADCINA3	Populate RC filter if required
	J5.6 (46)	PGA2_OF	ADCINA4	Remove R19 if PGA output filter is required
	J7.27 (67)	PGA4_IN	ADCINC3	Populate RC filter if required
	J5.5 (45)	PGA4_OF	ADCINB4	Remove R25 if PGA output filter is required
	J7.28 (68)	PGA6_IN	ADCINC5	Populate RC filter if required
	J5.8 (48)	PGA6_OF	ADCINA8	Remove R22 if PGA output filter is required
	J5.2 (42)	PGA2/4/6_GND	–	Connected to PCB GND by default. Remove R27 is PGA_GND isolation is required

2.2 Debug Interface

2.2.1 XDS110 Debug Probe

The F28004x LaunchPad includes an on-board XDS110 Debug Probe. The XDS110 allows for the programming and debugging of the F280049C using Code Composer Studio™ or any other supported tool chains. In the current configuration, the XDS110 is only wired to support 2-pin cJTAG mode. This uses only the TMS and TCK JTAG pins and allows for TDI and TDO to be reallocated for application needs.

TDI and TDO are available on GPIO35 and GPIO37. Though these pins are not routed to the debug probe, by default, they are available at the BoosterPack connector. GPIO35 and GPIO37 can also be routed to J101 using a combination of S3 and S4. For the proper configuration, see [Section 2.3](#).

2.2.2 XDS110 Output

The connector J102 is provided to debug an external target with the on-board XDS110 debug probe. This connector allows the LaunchPad to be used as a stand-alone XDS110 debug probe. If the LaunchPad is being used in this manner, ensure that all of the shunts are removed from J101. This isolates the JTAG signals from going to the F280049C MCU.

2.2.3 Virtual COM Port

When plugged into a USB host, the XDS110 enumerates as both a debugger and a virtual COM port. J101 allows the user to connect the SCI UART from the F280049C to the debug probe to be passed on to the USB host. By default, SCIA maps to the virtual COM port of the XDS110 using GPIO28 and GPIO29. Alternately, GPIO35 and GPIO37 can be used for SCIA. This is accomplished by manipulating S3, S4, and S8. For the appropriate switch settings, see the [Section 2.3](#).

2.3 Alternate Routing

2.3.1 Overview

The F280049C MCU is a very versatile device in a small package. To balance compatibility with BoosterPack standards as well as showcasing the versatility of the F280049C, some complexity was added to the design. Most features aligning with the BoosterPack standard are available by default. The additional functions are selected using a switches, or static resistors which can be added or removed. This section covers the alternate functions and how to enable them. Note that by enabling certain alternate features, standard BoosterPack functionality may be lost. The switches are configured such that it is not possible to connect multiple functions to the same header.

Table 4 is a master list of all of the possible functions controlled by the alternate routing switches:

Table 4. Alternate Function Switch Settings

Pins	S3.1	S3.2	S4	S6	S8	S9	Function	Note
GPIO28/GPIO29	x	x	x	0	0	x	SCIA to virtual COM port	Default configuration
	x	x	x	1	x	x	SCIA to BoosterPack Site 2	
GPIO35/GPIO37	1	x	1	x	1	x	SCIA to virtual COM port	
	1	x	0	x	x	x	I2C on BoosterPack Site 1	Default configuration
	0	x	1	x	x	x	QEP1 on J12	
GPIO59	0	x	x	x	x	x	QEP1 on J12	
	1	x	x	x	x	x	GPIO on BoosterPack Site 1	Default configuration
GPIO14/GPIO15/ GPIO26	x	0	x	x	x	x	QEP2 on J13	
	x	1	x	x	x	x	GPIO on BoosterPack Site 2	Default configuration
GPIO32/GPIO33 (2)	x	x	x	x	x	0	CAN on J14	
	x	x	x	x	x	1	GPIO on BoosterPack Site 2	Default configuration

(1) Cells marked with 'x' indicate that the state of that switch has no impact on the function of that particular signal.

(2) GPIO33 is also connected to the FSIRXCLK pin on J11 through a 0 Ω resistor R46. If CAN functionality is required, ensure that R46 is populated.

2.3.2 UART

This LaunchPad allows for one of two sets of pins to be used for the SCIA UART routed to the virtual COM port of the XDS110. By default, GPIO28 and GPIO29 are routed to the virtual COM port and not available on the BoosterPack connector. Alternately, GPIO35 and GPIO37 can be routed to the virtual COM port.

When UART functionality is not needed at the virtual COM port, the GPIOs can be routed to the BoosterPack connectors for BoosterPack standard functions.

2.3.3 eQEP

The LaunchPad has the ability to connect to two independent linear or rotary encoders through the F28004x on-chip eQEP interfaces: Header J12 is connected to eQEP1 and header J13 is connected to eQEP2. By default, this connection is not active and the GPIOs are routed to the BoosterPack connectors. The eQEP signals are routed through TI SN74LV4053A Triple 2-Channel Analog Multiplexer/Demultiplexer ICs (U8/U9) to select the functions. Once the eQEP signals have been selected through U8/U9, the 3.3 V signals are stepped up through a TI TXB0106PWR Level Translator (U7) to 5 V at the connectors.

2.3.3.1 EQEP1

GPIO35, GPIO37, and GPIO59 are routed to J12 through U9. By setting position 2 (LEFT) of S3 to 0 (DOWN), the eQEP signals are routed to J12. GPIO35 and GPIO37 also require that S4 is set to 1 (UP). In addition to configuring the switches, ensure that the EQEP1 function is selected in the GPIO Mux.

2.3.3.2 EQEP2

GPIO14, GPIO15, and GPIO26 are routed to J13 through U8. By setting position 1 (RIGHT) of S3 to 0 (DOWN), the eQEP signals are routed to J13. In addition to configuring the switches, ensure that the EQEP2 function is selected in the GPIO Mux.

2.3.4 CAN

The LaunchPad can be connected to a CAN bus through J14. GPIO32 and GPIO33 are routed to the on-board TI SN65HVD234 3.3 V CAN Transceiver, U10. By setting S9 to 0, GPIO32 and GPIO33 are routed to the transceiver. If S9 is set to 1, the GPIOs are routed to the BoosterPack connectors. As GPIO33 is also used by the FSI, ensure that R46 is populated with a 0-Ω resistor to connect GPIO33 to the CAN transceiver.

2.3.5 FSI

One set of GPIOs with available FSI functionality is directly connected to both the BoosterPack connectors as well as the FSI header, J11. To simplify the layout of the LaunchPad, 0-Ω resistors are placed on the signal trace to remove the BoosterPack Connection from the circuit. The mapping between the GPIOs, the resistors, and the FSI signal is listed in [Table 5](#). R46 also connects GPIO33 to S9, which selects the route to the BoosterPack connector or the CAN transceiver.

Table 5. FSI to BoosterPack Isolation Resistors

GPIO	Resistor	FSI Signal
GPIO25	R72	FSITXAD1
GPIO6	R44	FSITXAD0
GPIO7	R45	FSITXACLK
GPIO2	R71	FSIRXAD1
GPIO12	R47	FSIRXAD0
GPIO33	R46	FSIRXACLK

2.3.6 GPIO18/X2

The F280049C oscillator clock output signal, X2, is multiplexed with GPIO18. By default, the Launchpad uses an on-board crystal oscillator, Y2, as the clock source for the on-chip Phase-Locked Loop (PLL) that requires both X1 and X2 signals of the MCU. To balance the requirement of having cleanly routed oscillator signals and bringing all possible GPIOs to the BoosterPack connectors, GPIO18/X2 can be routed to the BoosterPack connectors through a 0 Ω resistor. If GPIO18 is needed at the BoosterPack connector, the on-chip zero-pin oscillators must be used as the clock source for the on-chip PLL. For more information on the X1/X2 configurations, see the device-specific data sheet.

If GPIO18 functionality is needed at the BoosterPack Connector:

1. Remove R31 to separate GPIO18 from Y2.
2. Populate R28 to connect GPIO18 to the BoosterPack connector.
3. Populate R35 to connect X1 to Ground.

3 Software Development

This section provides general information about software development, as well as instructions for programming the LaunchPad.

3.1 Software Description

C2000Ware includes a set of example applications that use the C2000Ware Peripheral Driver Library. These applications demonstrate the capabilities of the F28004x series MCU, as well as provide a starting point for the development of the final application for use on the F28004x LaunchPad development board. Example applications are also provided for the F28004x LaunchPad when paired with selected BoosterPacks.

3.2 Source Code

The complete source code including the source code installation instructions are provided at <http://www.ti.com/tool/c2000ware>. The source code and binary files are installed in the C2000Ware software tree.

3.3 Tool Options

The source code installation includes directories containing projects, makefiles, and binaries for Texas Instruments' Code Composer Studio IDE.

Download evaluation versions of these tools from the [Tools & Software](#) section of www.ti.com/c2000. CCS provides the application debug environment for developing, programming, and debugging code on the C2000 family of microcontrollers.

3.4 Programming the F28004x LaunchPad

The F28004x LaunchPad software package includes pre-built binaries for each of the example applications. If you installed the C2000Ware software to the default installation path of `C:\ti\c2000\C2000Ware_<version>`, you can find the example applications in `C:\ti\c2000\C2000Ware_<version>\examples`. The on-board XDS110 is used with the On-Chip Flash Programmer tool to program applications on the F28004x LaunchPad.

Follow these steps to program example applications into the F28004x LaunchPad development kit using the on-board XDS110 debug probe:

1. Install CCS on a PC running Microsoft Windows.
2. Connect the USB-A cable plug in to an available USB port on the PC and plug the Micro-B plug to the port (USB101) on the F28004x LaunchPad.
3. Verify that LED0, at the top of the board is illuminated indicating USB power as well as LED1, which indicates the target and debugger are powered.
4. Install Windows XDS110 and Virtual COM Port drivers if prompted. Installation instructions can be found at <http://processors.wiki.ti.com/index.php/XDS110>.
5. Run CCS on the PC.
6. Launch the Target Configuration included in the project. Ensure that the Target Configuration configured to use the 2-pin cJTAG advanced configuration.
7. Click Load Program and select the program to load.

4 Board Design

4.1 Schematic

This section contains the complete schematics for the F28004x LaunchPad, as shown in [Figure 4](#) to [Figure 11](#).

The source files for the schematic are provided in `C2000Ware_<version>\boards\LaunchPads\LAUNCHXL_F280049CVA\design files`

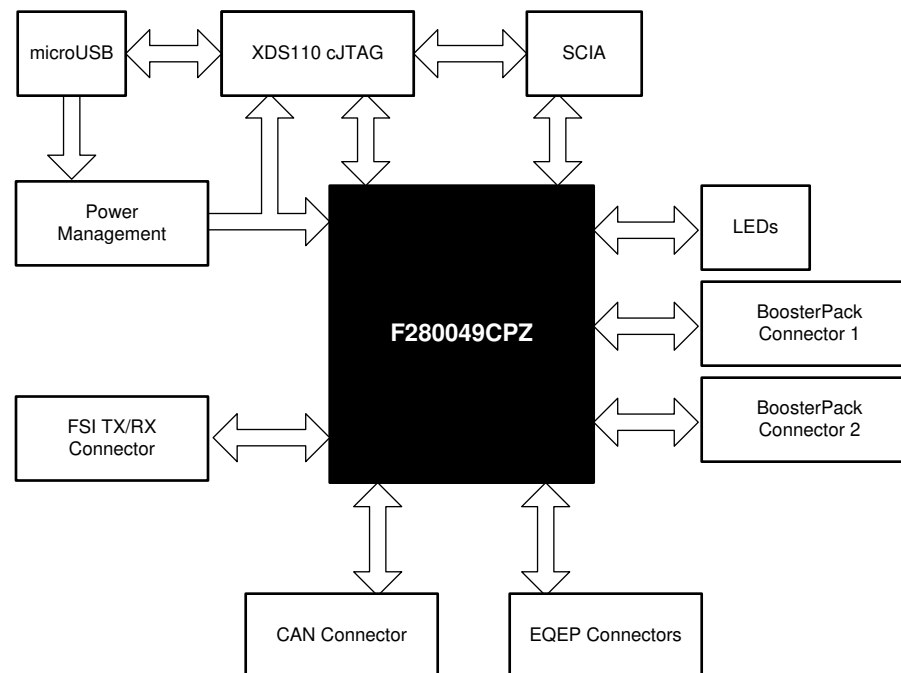
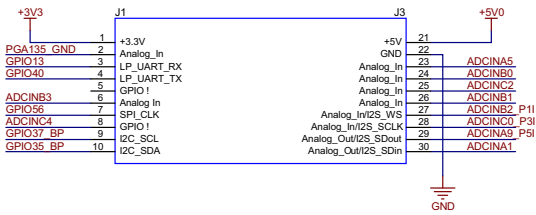
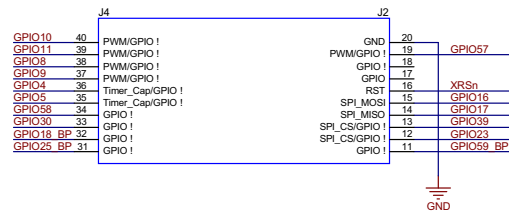

Figure 4. MCU025B_Block_Diagram.SchDoc



Booste rPack Headers Site 1 (Top)



J5 - J8 are labeled on the PCB. The Pin numbers listed on these schematic components should be offset by 40, i.e. pin 1 on J5 is labeled as pin 40 on the PCB.

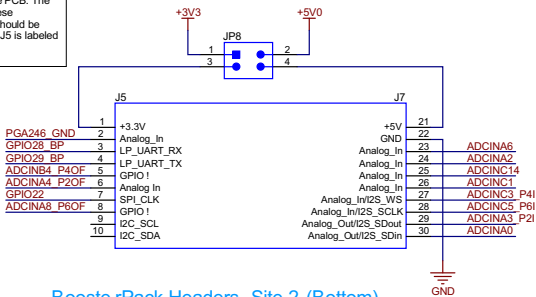

Booste rPack Headers Site 2 (Bottom)

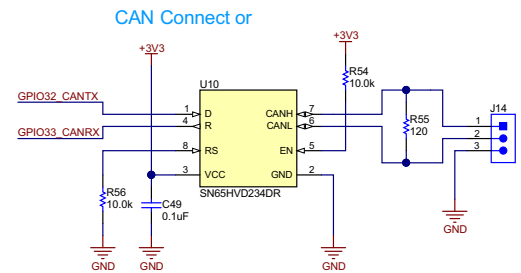
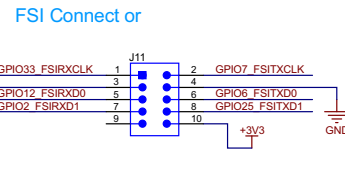
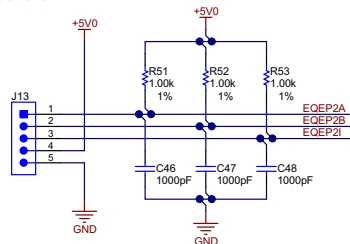
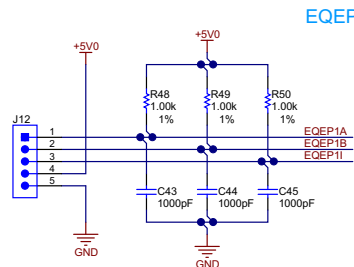
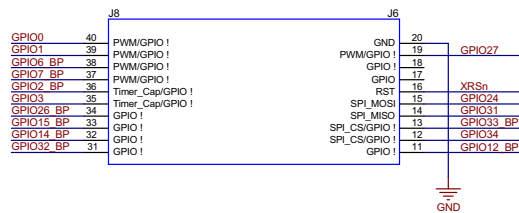

Figure 5. MCU025B_Connectors.SchDoc

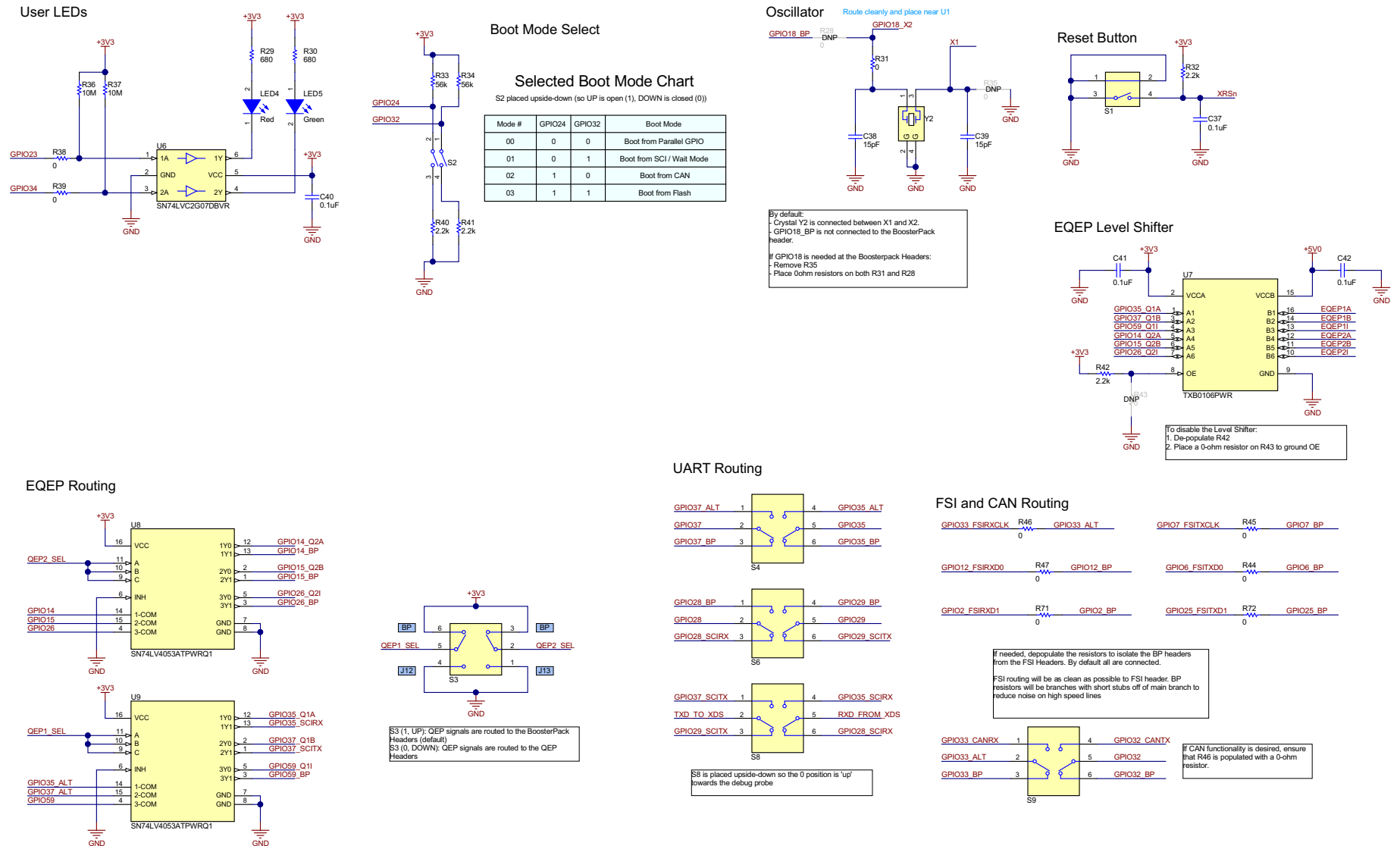

Figure 6. MCU025B_AltRouting_Misc.SchDoc

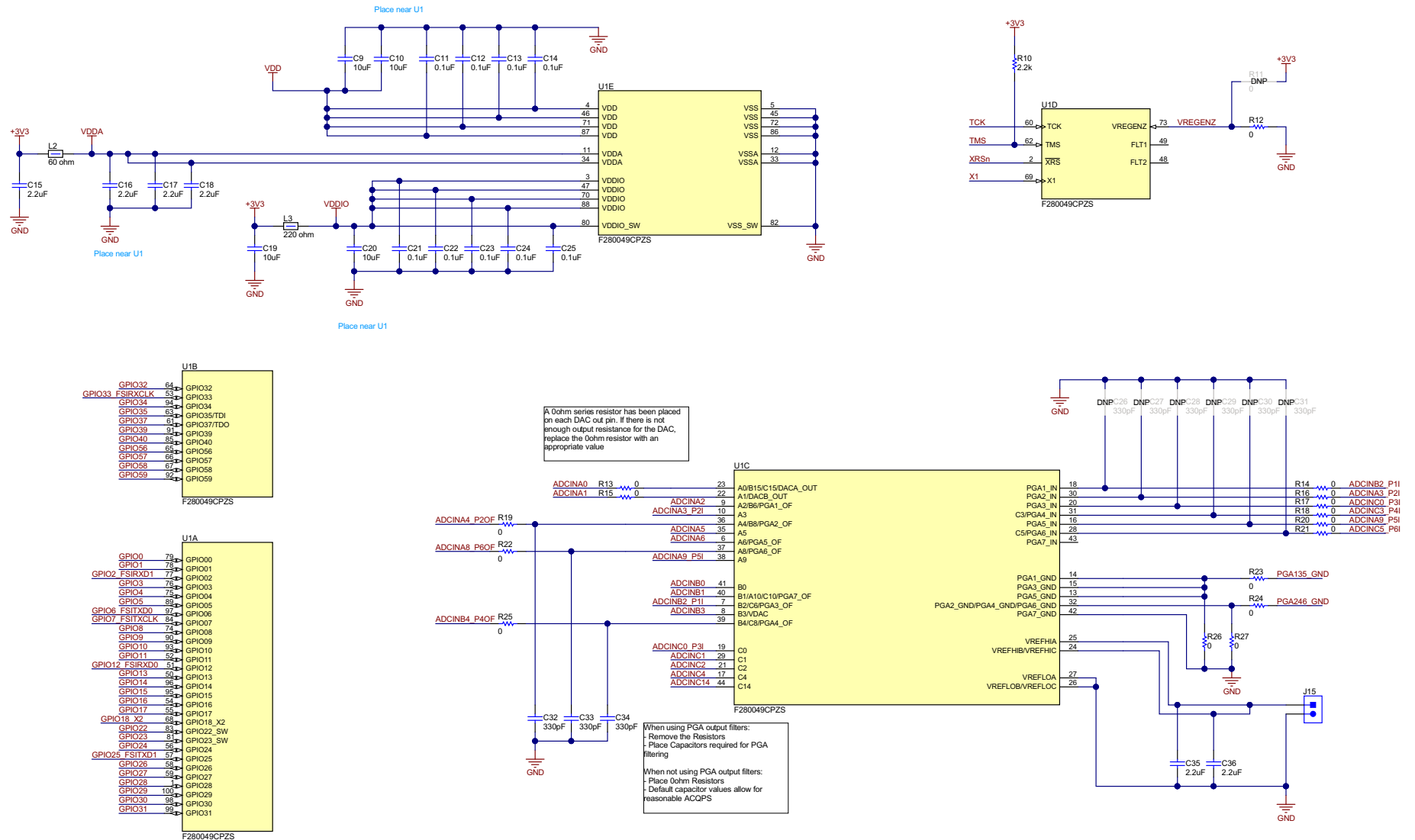
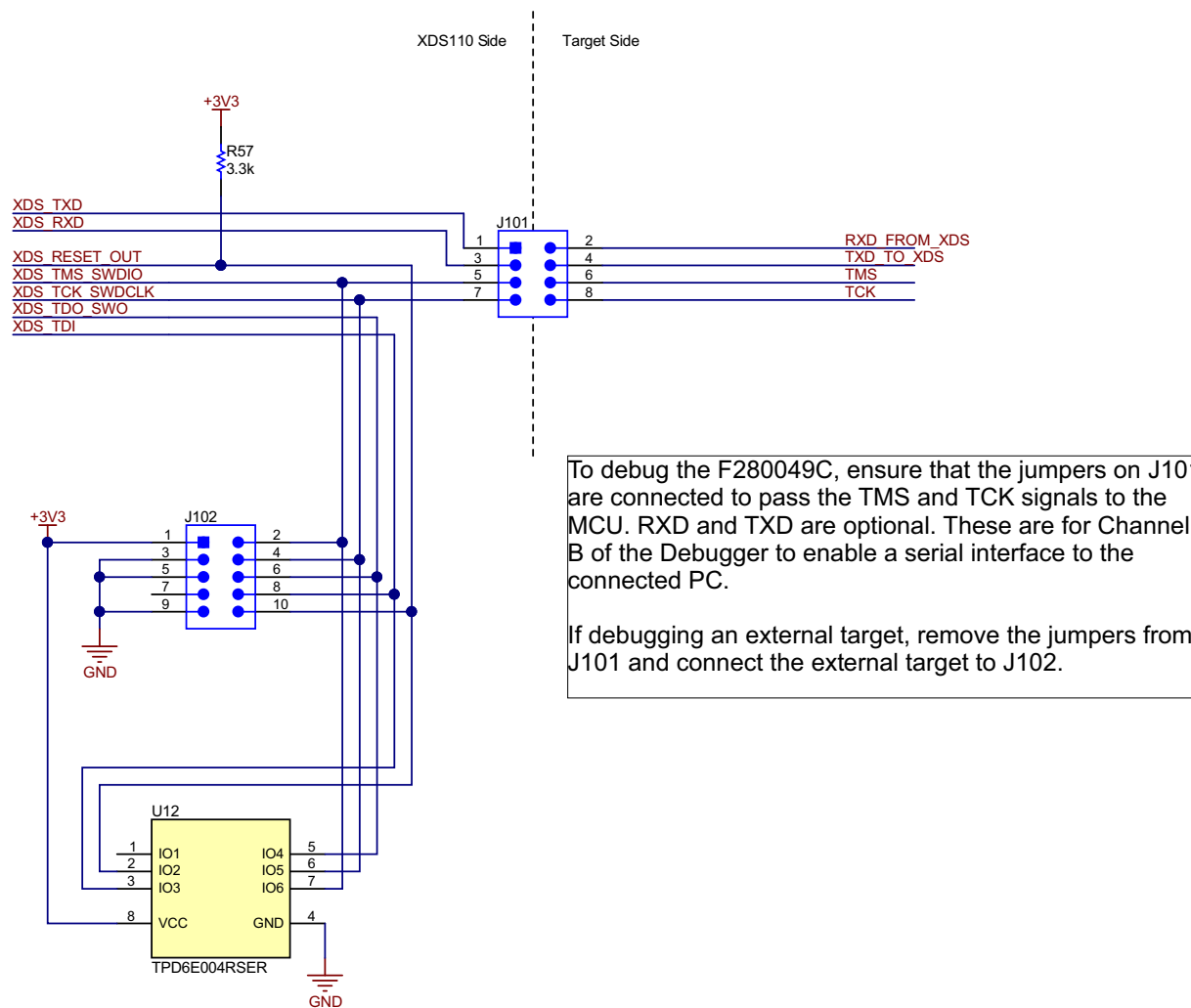

Figure 7. MCU025B_F280049C_Device.SchDoc



To debug the F280049C, ensure that the jumpers on J101 are connected to pass the TMS and TCK signals to the MCU. RXD and TXD are optional. These are for Channel B of the Debugger to enable a serial interface to the connected PC.

If debugging an external target, remove the jumpers from J101 and connect the external target to J102.

Figure 8. MCU025B_XDS110_Target_Interface.SchDoc

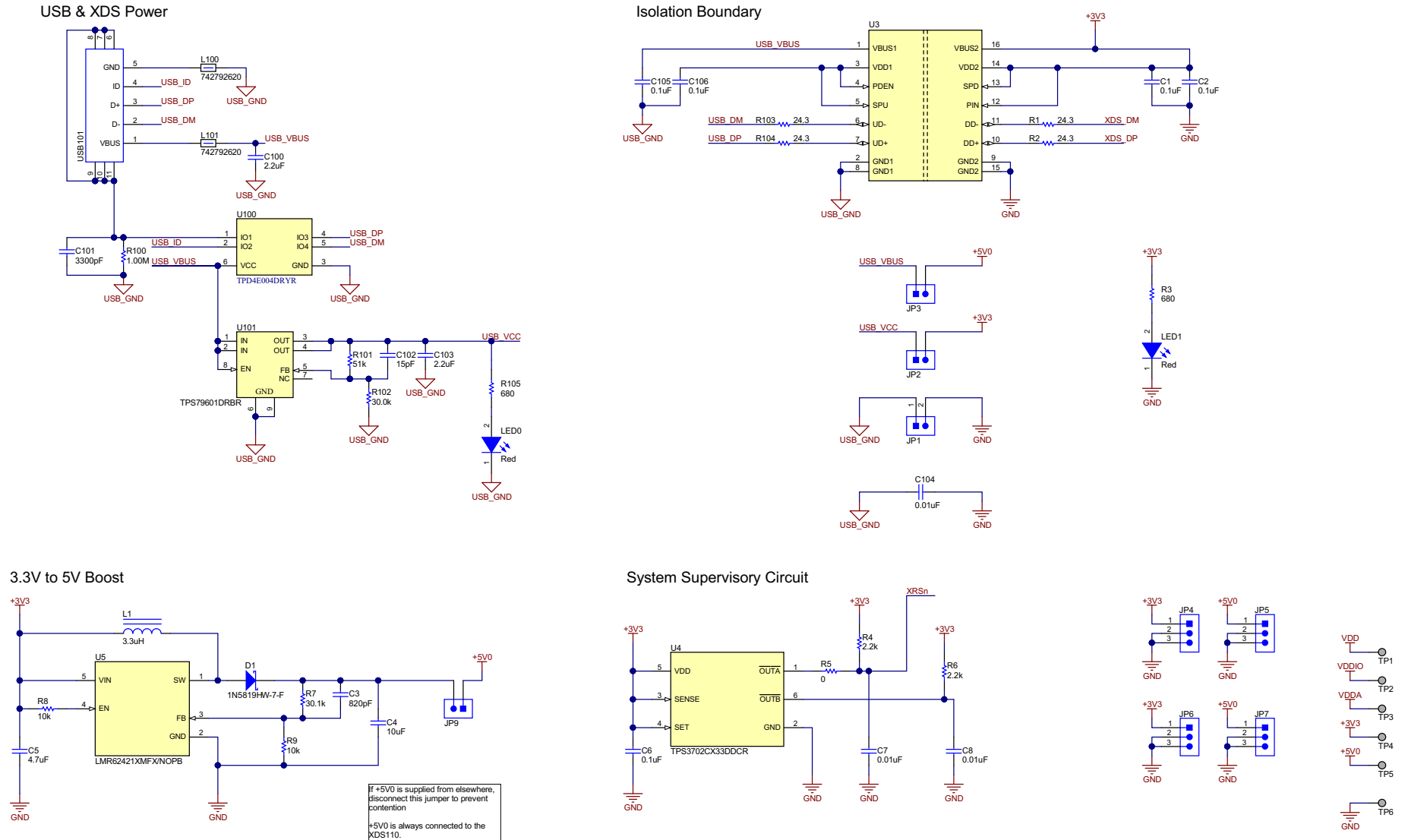

Figure 9. MCU025B_XDS110_USB_Power.SchDoc

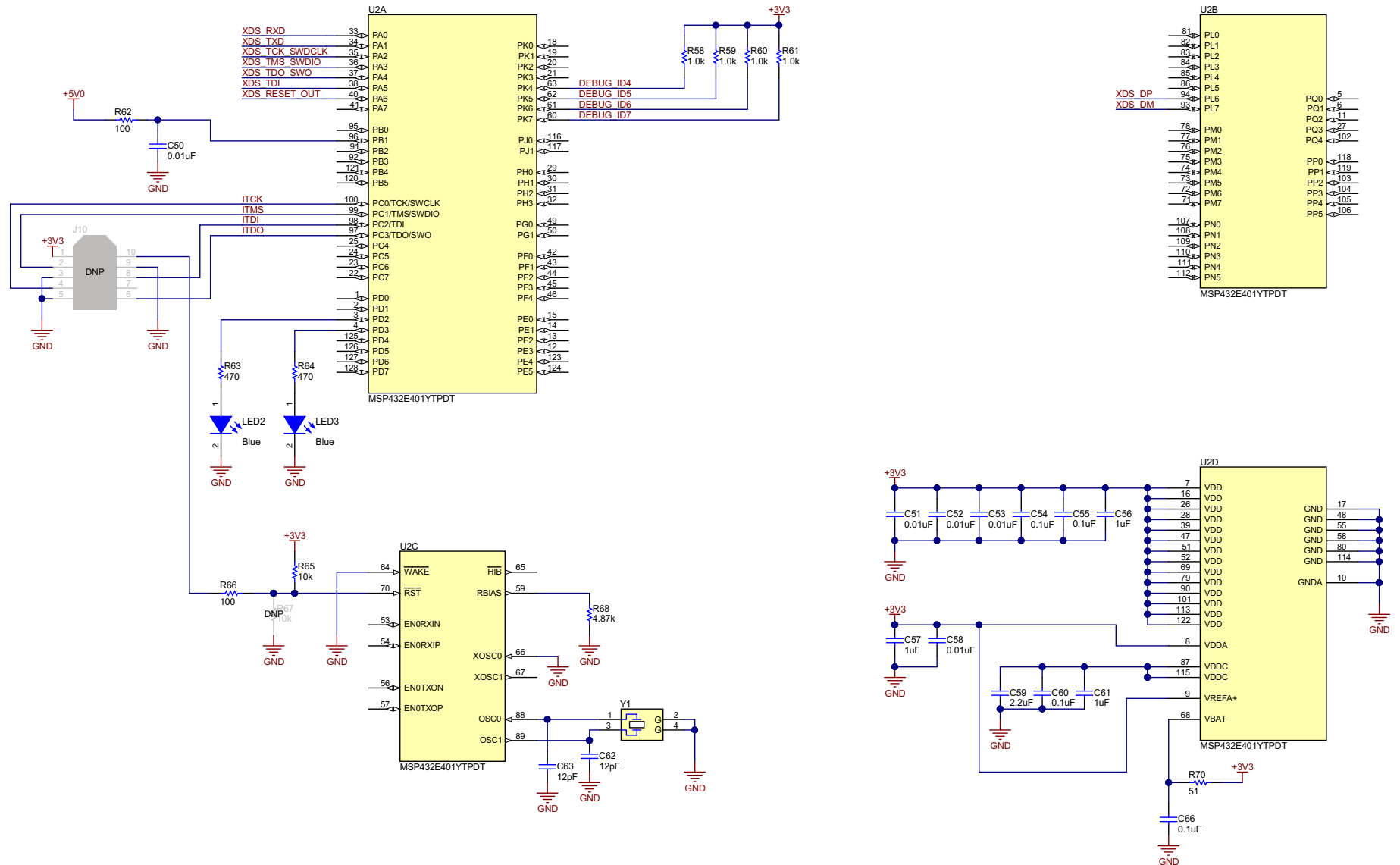
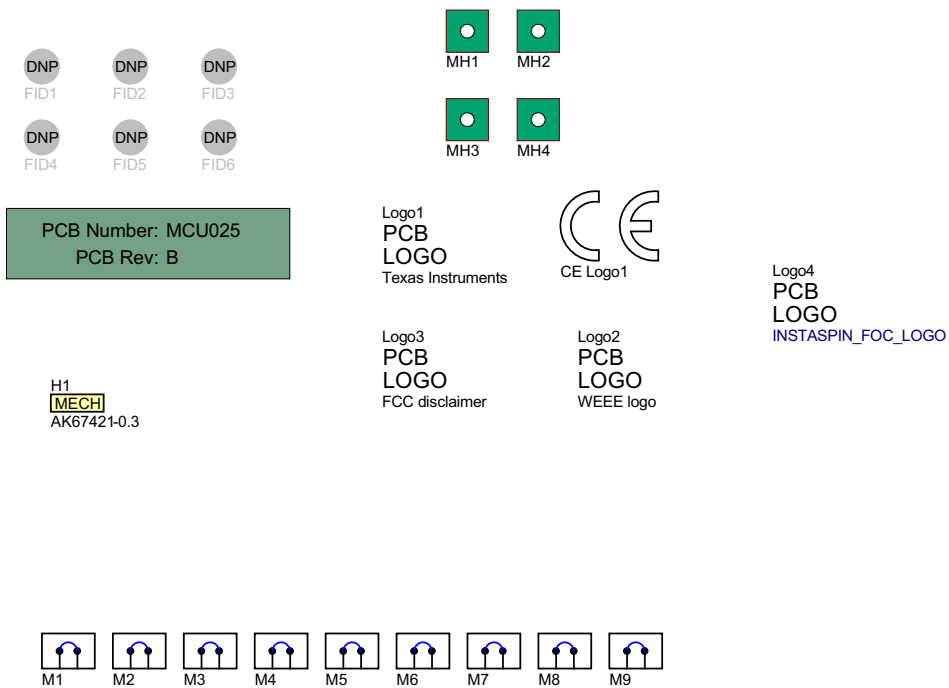

Figure 10. MCU025B_XDS110_MCU.SchDoc



ZZ2

Assembly Note

These assemblies are ESD sensitive, ESD precautions shall be observed.

ZZ3

Assembly Note

These assemblies must be clean and free from flux and all contaminants. Use of no clean flux is not acceptable.

ZZ4

Assembly Note

These assemblies must comply with workmanship standards IPC-A-610 Class 2, unless otherwise specified.

Figure 11. MCU025B_Hardware.SchDoc

4.2 Layout

The layout source files for the LAUNCHXL-F280049C are provided in *C2000Ware_<version>\boards\LaunchPads\LAUNCHXL_F280049CMCU025\design files*. The F28004x LaunchPad was created using Altium Designer 17. The gerber files are also provided in the same directory.

4.3 BOM

The BOM for the LAUNCHXL-F280049C is provided in *C2000Ware_<version>\boards\LaunchPads\LAUNCHXL_F280049CMCU025*.

4.4 LAUNCHXL-F280049C Board Dimensions

Figure 12 is a dimensional drawing of the F28004x LaunchPad that shows the location of selected features of the board as well as the component locations.

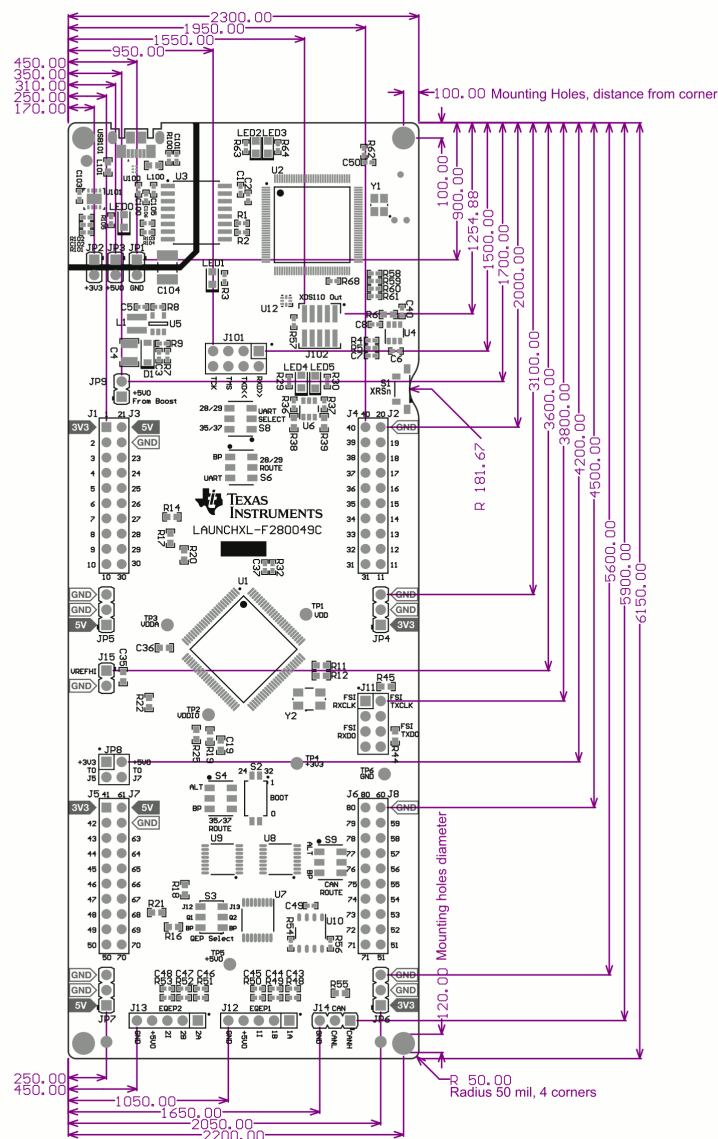

Figure 12. F28004x LaunchPad Dimensions and Component Locations

5 References

5.1 Reference Documents

In addition to this document, the following references are available for download at www.ti.com.

- [TMS320F280049C Piccolo™ Microcontrollers](#)
- [TMS320F28004x Piccolo™ Microcontrollers Data Sheet](#)
- [TMS320F28004x Piccolo™ Microcontrollers Technical Reference Manual](#)
- [TMS320C48004x Piccolo™ Microcontrollers Silicon Errata](#)
- [LAUNCHXL-F280049C LaunchPad Quick Start Guide](#)
- [C2000Ware for C2000 MCUs](#)
- [C2000Ware Quick Start Guide](#)
- [Texas Instruments Code Composer Studio](#)
- [Texas Instruments LaunchPad Development Environment](#)

5.2 Other TI Components Used in This Design

This LaunchPad uses various other TI components for its functions. A consolidated list of these components with links to their TI product pages is shown below.

- [TM4C129ENCPDT IoT Enabled High Performance 32-Bit Arm® Cortex®-M4F](#)
- [LM4040 Precision Micropower Shunt Voltage Reference](#)
- [LMR62421 Simple Switcher 2.7 V to 5.5 V, 2.1 A Step-Up Regulator](#)
- [SN65HVD234 3.3 V CAN Transceiver](#)
- [SN74LV4053A Triple 2-Channel Analog Multiplexer/Demultiplexer IC](#)
- [SN74LVC2G07 Dual Buffer/Driver With Open-Drain Output](#)
- [TPD4E004 4-Channel ESD Protection Array for High-Speed Data Interfaces](#)
- [TPD6E004 Low-Capacitance 6-Channel +/- 15 kV ESD Protection Array for High-Speed Data Interfaces](#)
- [TPS3702 High-Accuracy, Fixed-Threshold OV/UV Monitor](#)
- [TPS796 Ultralow-Noise, High PSRR, Fast, RF, 1-A Low-Dropout Linear Regulator](#)
- [TXB0106PWR 6-Bit Bidirectional Voltage-Level Translator](#)

A.1 Frequently Asked Questions

1. Can other programming and debug tools (such as an XDS200 debug probe) be used with the F28004x LaunchPad?

The F28004x LaunchPad utilizes an on-board XDS110 debug probe in a 2-pin cJTAG configuration. cJTAG only uses the TMS and TCK pins of the debug probe. TDI and TDO are present on the BoosterPack connectors and can be connected to a debug probe through jumper wires, if necessary.

2. What versions of Code Composer Studio can be used to develop software for the F28004x LaunchPad?

The on-board XDS110 debug probe is compatible with Code Composer Studio development environment version 6.1.0 and later.

3. Why can't I connect to the LaunchPad in Code Composer Studio?

- a. Are shunts present on J101 for TCK and TMS?
- b. Is the XDS110 and the F280049C MCU powered? Is LED1 illuminated?

If JP1, JP2, and JP3 are disconnected, the power provided through the USB is isolated from the rest of the board. Ensure that 3.3 V is supplied to any of the available connectors on the target side of the isolation.

- c. Is the micro-USB connected to the PCB and is the USB region receiving power? Is LED0 illuminated?

The USB region must be powered with the 5 V from the USB cable. LED0 will illuminate when the 5V is stepped down to 3.3 V for the USB isolation chip to operate and pass the signals across the isolation barrier.

- d. Ensure that the target configuration is set up to use cJTAG in 2-pin advanced mode.

Open the Target Configuration file (.ccxml) in Code Composer Studio. Click on the Advanced tab and select cJTAG (1149.7) 2-pin advanced modes from the drop-down labeled JTAG/SWD/cJTAG Mode. Leave the Target Scan Format as OSCAN2 format.

Alternately, a working Target configuration file is included in the `launcxl_ex1_f280049c_demo` project "TMS320F280049C_LaunchPad.ccxml". You can use this without modifications.

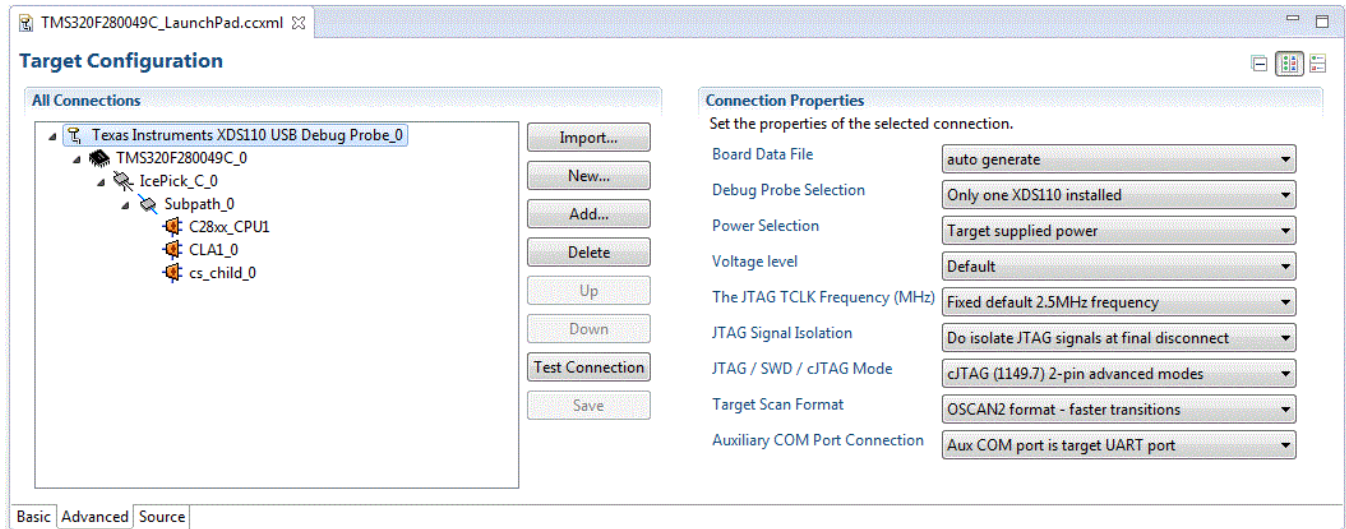

Figure 13. Target Configuration Advanced Options

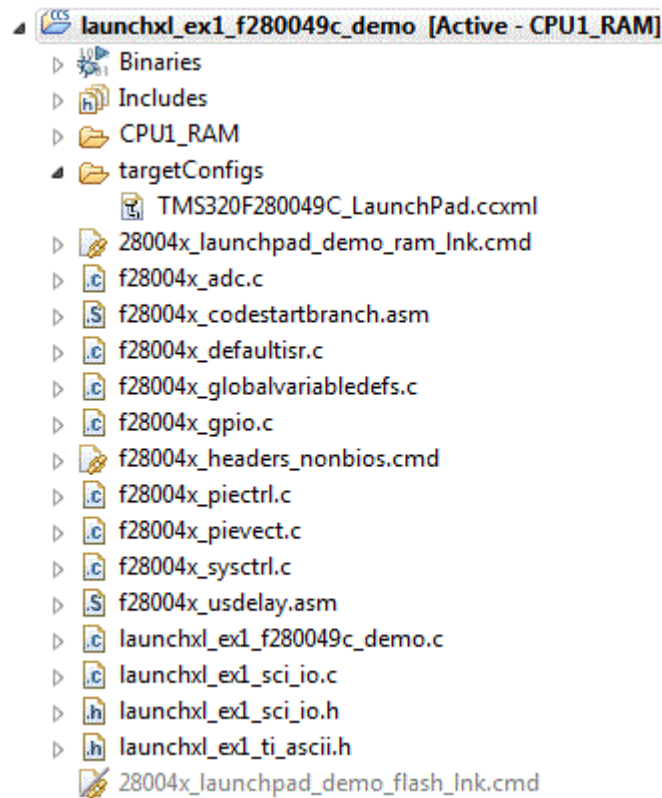

Figure 14. Target Configuration included in the demo project

4. Is XDS110 firmware version 2.3.0.16 installed? This is contained in Emulation Package 8.0.903.4. If so, this version of the XDS110 firmware breaks the cJTAG connection. To confirm which XDS110 firmware is used, and update the firmware, follow these steps:
 - a. Verify current XDS110 firmware version by connecting the LaunchPad to the PC through the USB cable and executing "xdsdfu -e" in the command prompt.

If the current version is not v2.3.0.16, move on to other methods to resolve the connection issues. Else, continue this procedure
 - b. Install the Emulation Package 8.1.0.00005 which contains the previous XDS110 v2.3.0.17 firmware using the instructions found [HERE](#). Alternatively, you can install the older Emulation Package 8.0.803.0 which contains XDS firmware version 2.3.0.15.
 - c. In a command prompt, navigate to the emulation driver within your CCS installation and execute the following commands. e.g. C:\ti\ccsv8\ccs_base\common\uscif\xds110\
 - xdsdfu -m
 - xdsdfu -f firmware.bin -r
 - d. Power cycle the LaunchPad.
 - e. Verify new XDS110 firmware version by again executing "xdsdfu -e" in the command prompt. Ensure that v2.3.0.16 is not installed.

NOTE: Prior to XDS110 version 2.3.0.14, the cJTAG connection with the F28004x MCU was not working. Ensure that version 2.3.0.14 or newer, with the exception of firmware version 2.3.0.16, is running on the XDS110. Any older versions of the XDS110 firmware will not operate as expected.

5. Why is the serial connection not working?
 - a. Are shunts present on J101 for TXD and RXD?
 - b. Are you using the correct COM port?

Right click on My Computer and select Properties. Navigate to the Hardware tab in the dialog box and open the device manager. Scroll to Ports (COM & LPT) and expand this entry. Is XDS110 Class Application/User UART listed? If so, read the COM number to the right of the entry; this is the COM number you should be using.
 - c. Are you using the correct baud rate?

Most, if not all, of the examples are configured for a baud rate of 115200 when the CPU is running at 100 MHz. If you have changed the PLL settings or developed your own code you may have to recalculate the baud rate for your specific application. For information on how to do this, see the [TMS320F28004x Piccolo™ Microcontrollers Technical Reference Manual](#).
 - d. Does the UART channel wired to the debug probe match the UART channel configured in your software?

The F28004x LaunchPad provides an option for one of two possible UART channels to be routed to the debug probe through J101. Ensure that S3, S4, S6, and S8 are configured to the appropriate UART channel for your application. For more information about the Alternate Routing possibilities, see [Section 2.3](#).

Revision History

NOTE: Page numbers for previous revisions may differ from page numbers in the current version.

Changes from A Revision (March 2019) to B Revision	Page
• Updated Figure 1	1
• Added new Section 1.7.2	5
• Updated Section 2.1.4	7
• Updated Figure 3	8
• Updated Section 2.1.7.1	8
• Updated Section 2.3.5	12
• Updated Section 4.1	14

IMPORTANT NOTICE AND DISCLAIMER

TI PROVIDES TECHNICAL AND RELIABILITY DATA (INCLUDING DATASHEETS), DESIGN RESOURCES (INCLUDING REFERENCE DESIGNS), APPLICATION OR OTHER DESIGN ADVICE, WEB TOOLS, SAFETY INFORMATION, AND OTHER RESOURCES "AS IS" AND WITH ALL FAULTS, AND DISCLAIMS ALL WARRANTIES, EXPRESS AND IMPLIED, INCLUDING WITHOUT LIMITATION ANY IMPLIED WARRANTIES OF MERCHANTABILITY, FITNESS FOR A PARTICULAR PURPOSE OR NON-INFRINGEMENT OF THIRD PARTY INTELLECTUAL PROPERTY RIGHTS.

These resources are intended for skilled developers designing with TI products. You are solely responsible for (1) selecting the appropriate TI products for your application, (2) designing, validating and testing your application, and (3) ensuring your application meets applicable standards, and any other safety, security, or other requirements. These resources are subject to change without notice. TI grants you permission to use these resources only for development of an application that uses the TI products described in the resource. Other reproduction and display of these resources is prohibited. No license is granted to any other TI intellectual property right or to any third party intellectual property right. TI disclaims responsibility for, and you will fully indemnify TI and its representatives against, any claims, damages, costs, losses, and liabilities arising out of your use of these resources.

TI's products are provided subject to TI's Terms of Sale (www.ti.com/legal/termsofsale.html) or other applicable terms available either on ti.com or provided in conjunction with such TI products. TI's provision of these resources does not expand or otherwise alter TI's applicable warranties or warranty disclaimers for TI products.

Mailing Address: Texas Instruments, Post Office Box 655303, Dallas, Texas 75265
Copyright © 2020, Texas Instruments Incorporated

Looking for pricing, stock, or lifecycle information?

Click below to explore more details on WIN SOURCE:

 [View LAUNCHXL-F280049C on WIN SOURCE](#)

 [Texas Instruments](#) Information

Optimize Your Supply Chain with WIN SOURCE Solutions

-  Global Sourcing Solution
-  Obsolete Management
-  Cost Control Management
-  Shortage Management
-  Alternative Solution
-  Excess Inventory Management