



**THE DATASHEET OF  
1904150**



## PCB terminal block - MKDS 5 HV/3-9.52 - 1904150

Please be informed that the data shown in this PDF Document is generated from our Online Catalog. Please find the complete data in the user's documentation. Our General Terms of Use for Downloads are valid (<http://download.phoenixcontact.com>)



PC terminal block, Nominal current: 32 A, Nom. voltage: 1000 V, Pitch: 9.52 mm, Number of positions: 3, Connection method: Screw connection, Mounting: Soldering, Conductor/PCB connection direction: 0 °, Color: green, The article can be aligned to create different nos. of positions!

The figure shows a 2-pos. version of the product

### Why buy this product

- ✓ Versions with anti-rotation pins (MKDSV, recommended for 2-pos. connections)
- ✓ MKDS 5N HV high-voltage PCB terminal blocks with increased air and creepage distances
- ✓ Unlimited 600 V UL approval thanks to compact zigzag pinning (MKDS 5N HV/...ZB-6,35 and MKDS 5 HV/...-9,52-Z)



### Key commercial data

Packing unit	1
Minimum order quantity	1
Catalog page	Page 365 (CC-2011)
GTIN	 4 017918 187613
Custom tariff number	85369010
Country of origin	POLAND

### Technical data

#### Dimensions / positions

Length	28.56 mm
Height	21.5 mm
Width	16 mm
Pitch	9.52 mm
Dimension a	19.04 mm
Number of positions	3
Pin dimensions	0,9 x 0,9 mm
Hole diameter	1.3 mm
Screw thread	M3
Tightening torque, min	0.5 Nm
Tightening torque max	0.6 Nm

# PCB terminal block - MKDS 5 HV/3-9.52 - 1904150

## Technical data

### Technical data

Range of articles	MKDS 5 HV
Insulating material group	I
Rated surge voltage (III/3)	8 kV
Rated surge voltage (III/2)	8 kV
Rated surge voltage (II/2)	6 kV
Rated voltage (III/3)	800 V
Rated voltage (III/2)	1000 V
Rated voltage (II/2)	1000 V
Connection in acc. with standard	EN-VDE
Nominal current $I_N$	32 A
Nominal cross section	4 mm <sup>2</sup>
Maximum load current	32 A
Insulating material	PA
Inflammability class according to UL 94	V0
Internal cylindrical gage	A4
Stripping length	8 mm
Nominal voltage, UL/CUL Use Group B	300 V
Nominal current, UL/CUL Use Group B	30 A
Nominal voltage, UL/CUL Use Group C	300 V
Nominal current, UL/CUL Use Group C	30 A
Nominal voltage, UL/CUL Use Group D	600 V
Nominal current, UL/CUL Use Group D	5 A

### Connection data

Conductor cross section solid min.	0.2 mm <sup>2</sup>
Conductor cross section solid max.	6 mm <sup>2</sup>
Conductor cross section stranded min.	0.2 mm <sup>2</sup>
Conductor cross section stranded max.	4 mm <sup>2</sup>
Conductor cross section stranded, with ferrule without plastic sleeve min.	0.25 mm <sup>2</sup>
Conductor cross section stranded, with ferrule without plastic sleeve max.	4 mm <sup>2</sup>
Conductor cross section stranded, with ferrule with plastic sleeve min.	0.25 mm <sup>2</sup>
Conductor cross section stranded, with ferrule with plastic sleeve max.	4 mm <sup>2</sup>
Conductor cross section AWG/kcmil min.	24
Conductor cross section AWG/kcmil max	10
2 conductors with same cross section, solid min.	0.2 mm <sup>2</sup>
2 conductors with same cross section, solid max.	1.5 mm <sup>2</sup>
2 conductors with same cross section, stranded min.	0.2 mm <sup>2</sup>
2 conductors with same cross section, stranded max.	1.5 mm <sup>2</sup>
2 conductors with same cross section, stranded, ferrules without plastic sleeve, min.	0.25 mm <sup>2</sup>

# PCB terminal block - MKDS 5 HV/3-9.52 - 1904150

## Technical data

### Connection data

2 conductors with same cross section, stranded, ferrules without plastic sleeve, max.	0.75 mm <sup>2</sup>
2 conductors with same cross section, stranded, TWIN ferrules with plastic sleeve, min.	0.5 mm <sup>2</sup>
2 conductors with same cross section, stranded, TWIN ferrules with plastic sleeve, max.	2.5 mm <sup>2</sup>
Minimum AWG according to UL/CUL	30
Maximum AWG according to UL/CUL	10

## Classifications

### eclass

eCl@ss 4.0	27141109
eCl@ss 4.1	27141109
eCl@ss 5.0	27141190
eCl@ss 5.1	27141190
eCl@ss 6.0	27261101
eCl@ss 7.0	27440401

### etim

ETIM 3.0	EC001121
ETIM 4.0	EC002643
ETIM 5.0	EC002643

### unspsc

UNSPSC 6.01	30211801
UNSPSC 7.0901	39121432
UNSPSC 11	39121432
UNSPSC 12.01	39121432
UNSPSC 13.2	39121432

## Approvals

### Approvals

---

#### Approvals

UL Recognized / SEV / cUL Recognized / GOST / CCA / IECEE CB Scheme / GOST / cULus Recognized

---

#### Ex Approvals

---

#### Approvals submitted

---

# PCB terminal block - MKDS 5 HV/3-9.52 - 1904150

## Approvals

### Approval details

UL Recognized

	B	C	D
mm <sup>2</sup> /AWG/kcmil	30-10	30-10	30-10
Nominal current I <sub>N</sub>	30 A	30 A	5 A
Nominal voltage U <sub>N</sub>	300 V	300 V	600 V

SEV

mm <sup>2</sup> /AWG/kcmil	6
Nominal voltage U <sub>N</sub>	690 V

cUL Recognized

	B	C	D
mm <sup>2</sup> /AWG/kcmil	30-10	30-10	30-10
Nominal current I <sub>N</sub>	30 A	30 A	5 A
Nominal voltage U <sub>N</sub>	300 V	300 V	600 V

GOST

CCA

IECEE CB Scheme

GOST

cULus Recognized

## Accessories

### Accessories

### Marking

# PCB terminal block - MKDS 5 HV/3-9.52 - 1904150

## Accessories

Marker cards - SK U/3,8 WH:UNBEDRUCKT - 0803906



Marker cards, Sheet, white, Unlabeled, Can be labeled with: Plotter, Office-Drucksysteme, Mounting type: Adhesive

Marker pen - B-STIFT - 1051993



Marker pen, for manual labeling of unprinted Zack strips, smear-proof and waterproof, line thickness 0.5 mm

## Tools

Screwdriver - SZS 0,6X3,5 - 1205053



Actuation tool, for ST terminal blocks, insulated, also suitable for use as a bladed screwdriver, size: 0.6 x 3.5 x 100 mm, 2-component grip, with non-slip grip

## Drawings

### Diagram

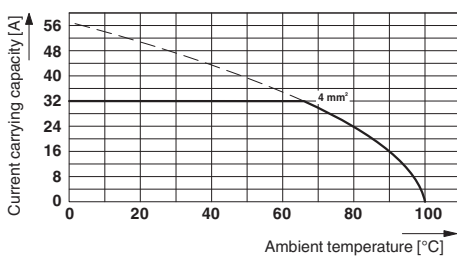

Type: MKDS 5 HV/2-9,52 and MKDS 5 HV/3-9,52  
Test following DIN EN 60512-5-2:2003-01  
Reduction factor = 1  
No. of positions: 5

### Dimensioned drawing

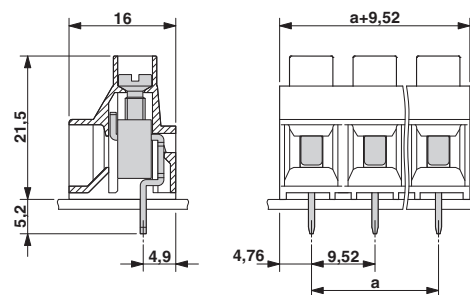

# PCB terminal block - MKDS 5 HV/3-9.52 - 1904150

Drilling diagram

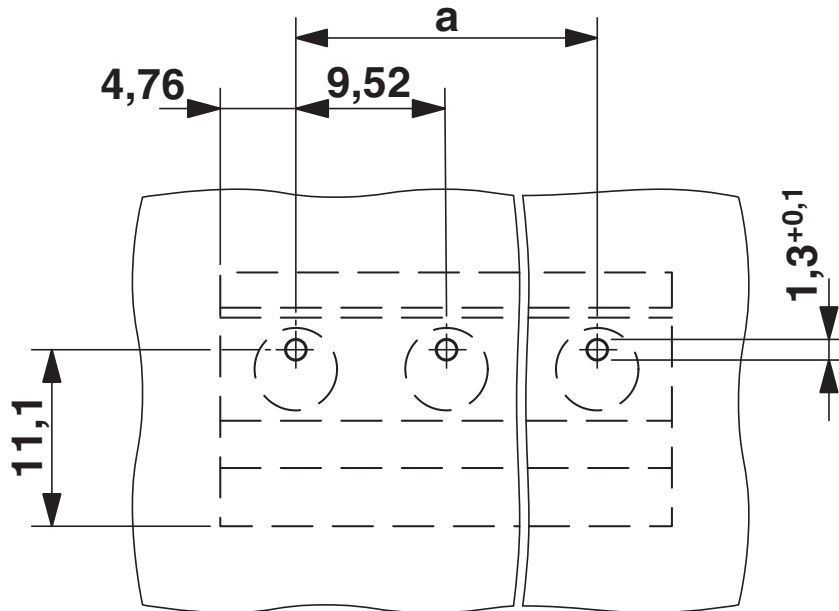



## Looking for pricing, stock, or lifecycle information?

Click below to explore more details on WIN SOURCE:

- [View 1904150 on WIN SOURCE](#)
- [Phoenix Contact Information](#)

## Optimize Your Supply Chain with WIN SOURCE Solutions

- ✓ Global Sourcing Solution
- ✓ Obsolete Management
- ✓ Cost Control Management
- ✓ Shortage Management
- ✓ Alternative Solution
- ✓ Excess Inventory Management