



Digital UART

Product Specification

PS038902-1116



Warning: DO NOT USE THIS PRODUCT IN LIFE SUPPORT SYSTEMS.

LIFE SUPPORT POLICY

ZILOG'S PRODUCTS ARE NOT AUTHORIZED FOR USE AS CRITICAL COMPONENTS IN LIFE SUPPORT DEVICES OR SYSTEMS WITHOUT THE EXPRESS PRIOR WRITTEN APPROVAL OF THE PRESIDENT AND GENERAL COUNSEL OF ZILOG CORPORATION.

As used herein

Life support devices or systems are devices which (a) are intended for surgical implant into the body, or (b) support or sustain life and whose failure to perform when properly used in accordance with instructions for use provided in the labeling can be reasonably expected to result in a significant injury to the user. A critical component is any component in a life support device or system whose failure to perform can be reasonably expected to cause the failure of the life support device or system or to affect its safety or effectiveness.

Document Disclaimer

©2016 Zilog, Inc All rights reserved. Information in this publication concerning the devices, applications, or technology described is intended to suggest possible uses and may be superseded. ZILOG, INC. DOES NOT ASSUME LIABILITY FOR OR PROVIDE A REPRESENTATION OF ACCURACY OF THE INFORMATION, DEVICES, OR TECHNOLOGY DESCRIBED IN THIS DOCUMENT. ZILOG ALSO DOES NOT ASSUME LIABILITY FOR INTELLECTUAL PROPERTY INFRINGEMENT RELATED IN ANY MANNER TO USE OF INFORMATION, DEVICES, OR TECHNOLOGY DESCRIBED HEREIN OR OTHERWISE. The information contained within this document has been verified according to the general principles of electrical and mechanical engineering.

ZMOTION and Z8 Encore! XP are trademarks or registered trademarks of Zilog, Inc. (An IXYS Company). All other product or service names are the property of their respective owners.

Revision History

Each instance in the revision history table reflects a change to this document from its previous revision. For more details, refer to the corresponding pages or appropriate links provided in the table below.

Date	Revision Level	Description	Page
Nov 2016	02	Corrected power supply voltage; updated Functional Description; updated Table 2; added a note for the Read System Status Register.	2 ; 10 ; 15 ; 39
Feb 2016	01	Original issue.	All

Table of Contents

Revision History	iii
Table of Contents	iv
List of Figures	vi
List of Tables	vii
Overview	1
Features	2
Applications	4
Block Diagram	5
Pin Description	6
Pin Configurations	6
Pin Descriptions	8
Functional Description	10
I ² C	10
Stacked Write Commands	10
I ² C Addressing	10
I ² C Protocol Overview	10
UART	11
Baud Rate	11
Flow Control	12
Watermark	12
Interrupt	13
EEPROM	13
I ² C EEPROM Operations	13
GPIO	14
Commands	15
Command List	15
EEPROM Command Detail	17
Write EEPROM at Current Location	17
Read EEPROM at Current Location	17
Write EEPROM Current Location Register	17
Read EEPROM Current Location Register	18
Erase EEPROM	18

GPIO Command Detail	19
Setting GPIO Out Register	19
Reading GPIO In Register	20
Write GPIO Configuration	20
Read GPIO Configuration	25
Read GPIO Interrupt Status Register	28
UART Command Detail	28
Read UART Status Register	28
Enable Interrupts	29
Interrupt Status Register	30
Write Data to TX FIFO	30
Read RX FIFO Data	30
Write Baud Rate Register	31
Read Actual Baud Rate Register	31
Write Configuration	32
Read Configuration	36
Write Transmit Watermark Register	37
Read Transmit Watermark Register	37
Write Receive Watermark Register	37
Read Receive Watermark Register	38
Enable UART	38
Read Receive and Transmit FIFO Level Registers	38
System Command Detail	39
Read System Status Register	39
Read Last Operation Result Register	39
Read System Version	39
Read Interrupt Source Register	40
Electrical Characteristics	41
Absolute Maximum Ratings	41
Recommended Operating Conditions	42
Power-on Reset Characteristics	42
Internal RC Oscillator Characteristics	43
DC Characteristics	43
Packaging	44
Ordering Information	48
Customer Support	49



List of Tables

Table 1. Pin Descriptions 8
Table 2. Command List 15
Table 3. Ordering Information 48

List of Figures

- Figure 1. Digital UART Block Diagram 5
- Figure 2. ZDU0110RFX Pin Configuration 6
- Figure 3. ZDU0110RHX Pin Configuration 6
- Figure 4. ZDU0110RJX Pin Configuration 7
- Figure 5. ZDU0110QUX Pin Configuration 7
- Figure 6. 32-Pin QFN Package 44
- Figure 7. 28-Pin TSSOP Package 45
- Figure 8. 20-Pin TSSOP Package 46
- Figure 9. 16-Pin TSSOP Package 47

Overview

Zilog's Digital Universal Asynchronous Receiver/Transmitter (UART) is a single-chip CMOS communications device which provides full duplex asynchronous communications with a 128 byte FIFO buffer, of which 64 bytes each are allocated to Receive and Transmit operations. This device also contains a 4 kbit EEPROM and General-Purpose Input and Output (GPIO) with programmable interrupt capability. Zilog's Digital UART has an internal 8 MHz oscillator, which eliminates the requirement for an external crystal oscillator.

This Digital UART is controlled by the simple I²C protocol (2-Wire Interface), allowing up to eight devices in the same I²C network. Although this device is fully programmable through the exposed commands, it is preconfigured to operate the UART at a 57,600 baud rate; therefore, configuration is not required to access the UART or the EEPROM.

Zilog's Digital UART provides separate programmable interrupts and interrupt lines for UART notification and GPIO notifications, so the controlling device does not have to poll the device for data.

Features

Zilog's Digital UART offers the following features:

- Single power supply from 1.8V to 5.0V
- No external crystal needed
- Minimal pin count for space saving
- Interrupt lines for UARTs and GPIOs for notification
- Control via I²C standard protocol, up to 400K
 - Up to 8 different addresses available
 - Can stack up to 8 parts on same I2C network
 - Ability to send multiple write commands in a single transfer
- No configuration necessary
 - Default UART setting: 57600 baud, no flow control, no parity, 8 bits
 - EEPROM is accessed through standard I2C EEPROM communications
 - GPIO configured as inputs
- Up to two industry standard full duplex individual UART channels
 - 64 byte receiver FIFO for each UART
 - 64 byte transmitter FIFO for each UART
 - Flow control using CTS and RTS pins
 - In band flow control using XON/XOFF
 - FIFO watermark settings for configuring interrupt lines
 - Programmable data formats
 - 5 to 8 bits data
 - Odd, Even or no parity
 - 1 or 2 stop bits
 - Loopback for testing
 - Flexible baud rate selection, in steps of 100 bits per second, up to 250K
 - Programmable Interrupts
- 4KB built-in I²C EEPROM
 - Standard I²C EEPROM communications
 - 300K times endurance
 - 10 year retention
- General Purpose Input Output pins

- Up to 12 GPIO pins
- 2 pins can generate interrupt on change of pin value
- Each pin is fully configurable
 - Individual pin configuration
 - Direction (input/output)
 - Open drain output option
 - Weak pull up option
 - Debounce option
 - Quickly return to default settings

Applications

The Digital UART is suitable for use in multiple applications; examples include:

- Point of Sale devices
- Communication bridges
- Process control
- Building/automation control
- Terminal servers
- Print systems

Block Diagram

Figure 1 shows a block diagram of the Digital UART.

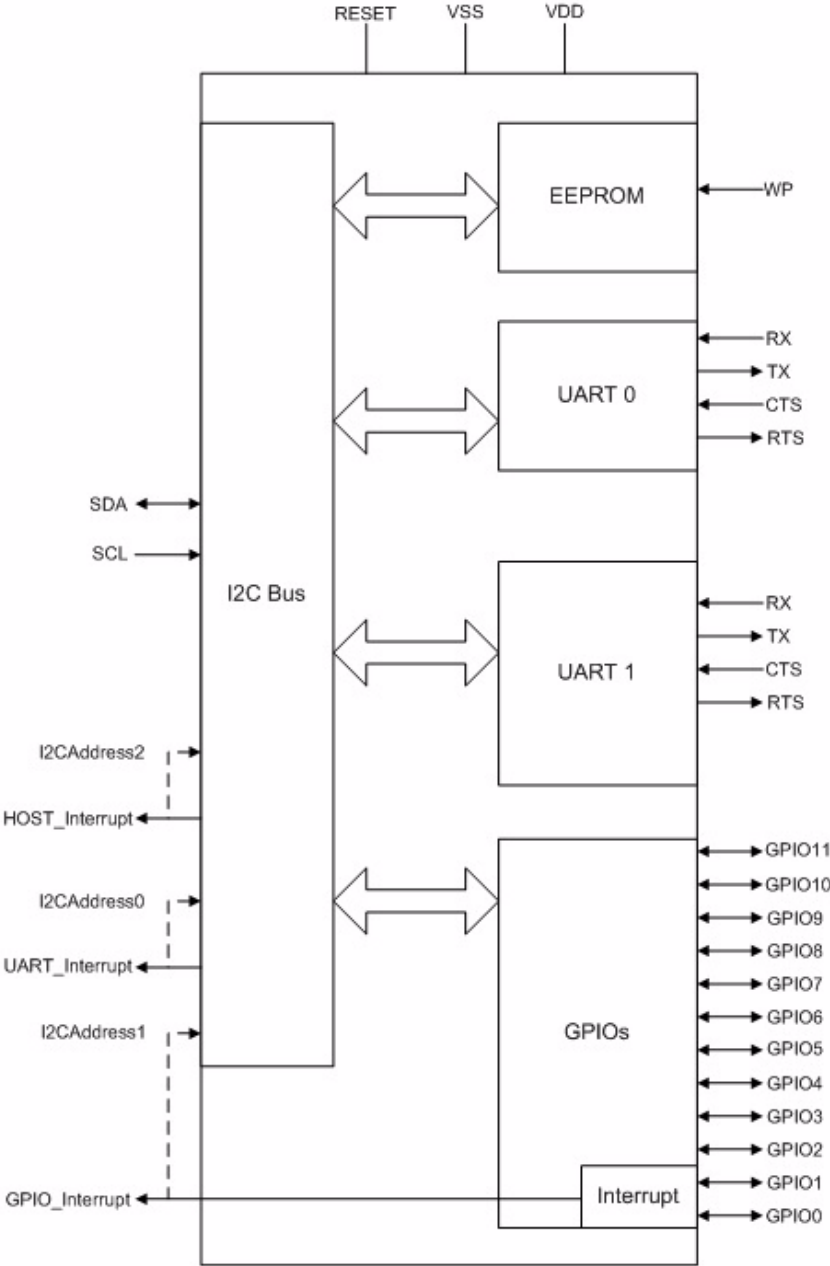

Figure 1. Digital UART Block Diagram

Pin Description

The Digital UART is available in a variety of package styles and pin configurations. This chapter describes the available pin configurations for each of the package style. To learn more about the physical package specifications, see the [Ordering Information](#) chapter on page 48.

Pin Configurations

Figures 2 through 5 show the pin configurations for each Digital UART package style.

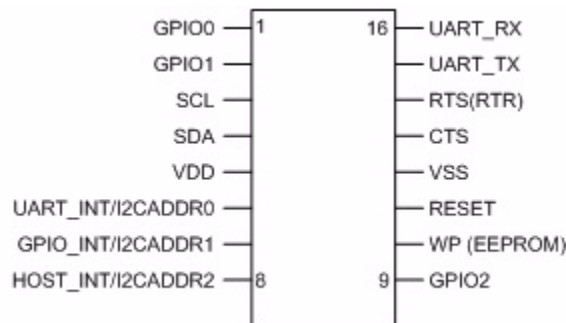

Figure 2. ZDU0110RFX Pin Configuration

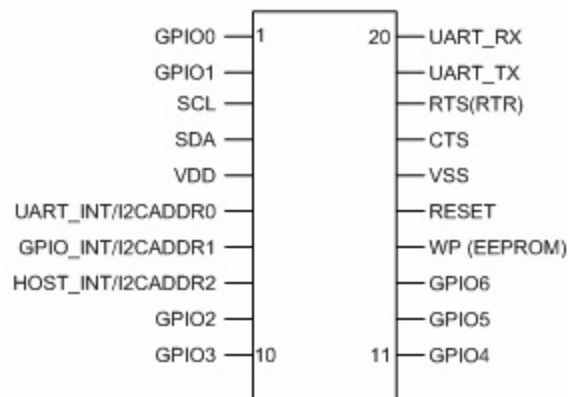

Figure 3. ZDU0110RHX Pin Configuration

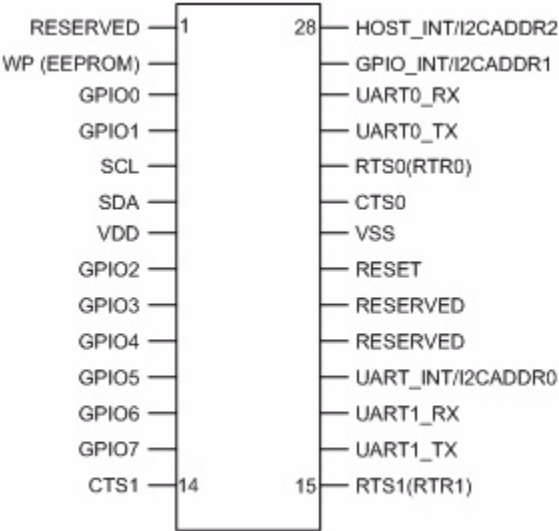

Figure 4. ZDU0110RJX Pin Configuration

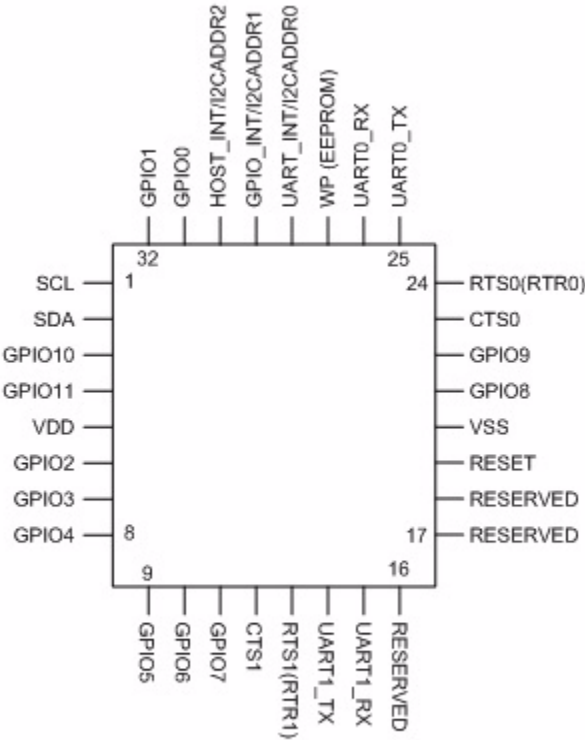

Figure 5. ZDU0110QUX Pin Configuration

Pin Descriptions

[Table 1](#) lists the pins and their descriptions.

Table 1. Pin Descriptions

Pin Number				Pin Name	Description	Direction
16	20	28	32			
3	3	5	1	SCL	I2C Serial Clock	IN
4	4	6	2	SDA	I2C Serial Data	IN/OUT
6	6	18	28	UART_INT/I2CADDR0	UART Interrupt Line ¹	OUT
7	7	27	29	GPIO_INT/I2CADDR1	GPIO Interrupt Line ¹	OUT
8	8	28	30	HOST_INT/I2CADDR2	HOST Interrupt Line ^{1,2}	OUT
15	19	25	25	UART0_TX	UART 0 Transmit	OUT
16	20	26	26	UART0_RX	UART 0 Receive	IN
13	17	23	23	CTS0	UART 0 Clear to Send	IN
14	18	24	24	RTS0(RTR0)	UART 0 Request to Send	OUT
–	–	16	14	UART1_TX	UART 1 Transmit	OUT
–	–	17	15	UART1_RX	UART 1 Receive	IN
–	–	14	12	CTS1	UART 1 Clear to Send	IN
–	–	15	13	RTS1(RTR1)	UART 1 Ready to Send	OUT
10	14	2	27	WP (EEPROM)	Write Protect for EEPROM ³	IN
1	1	3	31	GPIO0	General purpose I/O with Int	IN/OUT
2	2	4	32	GPIO1	General purpose I/O with Int	IN/OUT
9	9	8	6	GPIO2	General purpose I/O	IN/OUT
–	10	9	7	GPIO3	General purpose I/O	IN/OUT
–	11	10	8	GPIO4	General purpose I/O	IN/OUT
–	12	11	9	GPIO5	General purpose I/O	IN/OUT
–	13	12	10	GPIO6	General purpose I/O	IN/OUT
–	–	13	11	GPIO7	General purpose I/O	IN/OUT
–	–	–	21	GPIO8	General purpose I/O	IN/OUT
–	–	–	22	GPIO9	General purpose I/O	IN/OUT
–	–	–	3	GPIO10	General purpose I/O	IN/OUT

Table 1. (Continued)Pin Descriptions

Pin Number				Pin Name	Description	Direction
16	20	28	32			
–	–	–	4	GPIO11	General purpose I/O	IN/OUT
11	15	21	19	RESET	Active Low Reset	IN
5	5	7	5	VDD	Positive Supply	N/A
12	16	22	20	VSS	Ground	N/A
–	–	*	*	RESERVED	Reserved for future use ⁴	N/A

1 Interrupt lines are shared with the I2C Address selection. When system comes out of reset (either by bringing Reset pin low or operations.

2. Host Interrupt line is currently not used, Reserved for future use

3. Write Protect for EEPROM is to prevent writing to EEPROM. To Write to the EEPROM, this pin must be held low.

4. Reserved for future use pins are not used and should be pulled up to VDD

Functional Description

Upon power-up, the Digital UART device reads the I²C addresses for the correct configuration and addressing. The system then asserts all interrupt pins, configures the I²C host interfaces, configures all the peripherals to the default configurations and then de-asserts all interrupts, notifying the host that the initialization is completed. While the interface is being configured, communications are not possible; however, after the host interface has been configured, the system will respond to a system status command while the rest of the system is being initialized. After all write transactions, the I²C will NAK any start packet until the write command has been processed, including the system status command.

I²C

The Digital UART is an I²C slave device using a 7 bit address (Bit 0 specifies the Read or Write operation). The maximum bus speed that the Digital UART can support is 400 kHz. This device has up to eight possible addresses, allowing up to 8 devices on a single I²C bus. The I²C bus uses two bi-directional open-drain lines, pulled up to VDD with resistors. All I²C transactions must be separated by a wait period of at least 4 microseconds.

Stacked Write Commands

The Digital UART supports stacked write requests for multiple commands at the same time (up to a 64-byte packet). A *stacked* packet allows the Host to use one transaction to write to multiple commands, such as when configuring UART and/or GPIOs. If there is an error in the packet, packet processing is stopped and the error condition is logged in the System Status Register until the next request is processed.

I²C Addressing

The device responds to the following two addresses:

- 1010XXXb where XXX is the address configured using the I2CADDR pins
To be used to access the EEPROM through de facto standard interface
- 1011XXXb where XXX is the address configured using the I2CADDR pins
To be used to access the commands through standard I²C protocol.

I²C Protocol Overview

The Master is responsible for generating the serial clock (SCL) and generates the start and stop conditions on the data line (SDA). The Master can only send data when the bus is not busy, as defined by both data and clock lines remaining high.

A transfer starts with a High to Low transition of the SDA line while the SCL is high. The state of the data line is valid data when the SCL line is high. The SDA can only be changed while the SCL is low. The receiving device can keep the SCL line low to suspend the transaction. After the receiving device releases the SCL line, the transaction can continue. Each byte must be acknowledged by the receiving device.

To acknowledge the byte, the receiving device pulls down the SDA during the acknowledge clock pulse so that while the clock pulse is in a low state, the SDA is in a stable low state when the clock is high. If the SDA is high during the acknowledge cycle, it is considered *Not Acknowledged*, signaling the end of the packet. The Master then follows with a stop condition, transitioning a Low to High on the SDA line while the clock is high.

The first byte following the Start condition from the master device is an address byte. The address byte consists of 7 bits plus a Read/Write (R/W) bit. If the address sent was acknowledged, then a slave device responded, so the transaction can continue. If an acknowledge was not received, the master device issues a stop condition and ends the transaction.

If the R/W bit was a Read request, then the master sends 8 pulses to receive the data. If the master has more to read during this transaction, the master acknowledges the byte and repeats the process. After the requested data is completed, the master sends a stop condition to end the transaction.

If the R/W bit was a Write request, the master continues to send the data until either all the data was sent or a byte was not acknowledged. After the write transaction is complete, if a read transaction is necessary the master device can send a Start condition (without the Stop condition) to change to a read request. When the transaction is complete, a Stop condition is sent to end the transaction.

UART

The UART peripheral is a fully programmable, flexible, and preconfigured serial port. When powered up, the default setting is 57600 baud rate, 8 bits, no parity, no flow control. This setting allows the host to send and receive data as soon as the Digital UART is operational, with no configuration necessary. The UART peripheral can be configured for different baud rates in multiples of 100, up to 230K. The UART can also be configured for 5,6,7, or 8 bit data transfers; multiple flow control options; 1 or 2 stop bits; Odd, Even or no parity. The UART also has the ability to set different conditions to notify the host through the interrupt line.

Baud Rate

The baud rate is configured in units of 100; however, due to the 8MHz clock, the actual rate may be different. Use the following equation to calculate the actual baud rate:

$$\frac{10000}{\text{Round}(10000 \div (\text{requestedbaud}))} \times 100$$

The baud rate in the register will be the integer of actual baud rate divided by 100.

Example:

Requested Baud Rate:	576 (57600 / 100)
Actual Rate:	10000/(Round(10000/576)) * 100 = 58,823
Baud Rate Register	588

Flow Control

Two types of flow control are available on the Digital UART. Flow control provides the signaling between the UART connections to indicate that it is safe to send data. Flow control is recommended for maximum reliability and the preferred method is hardware flow control. For flow control to work, both devices must be configured for the same type of flow control.

Hardware Flow Control

Hardware flow control provides two extra pins to enable the sending/receiving of data from the UART TX/RX pins. The local Clear to Send (CTS) pin is connected to the remote Request to Send (RTS) pin. The Remote CTS is connected to the Local RTS. The CTS pin is an active low input pin, while the RTS pin is an output pin.

When the receiver is ready to receive data, the receiving UART brings the RTS pin (which is connected to the transmitter's CTS pin) low. The CTS pin going low signals the transmitter to send the data.

Software Flow Control

Software Flow control is signaled through in-band communications. The receiver controls the transmission by sending the XON (0x11) and XOFF (0x13) characters to the transmitter. When the receiver is not ready to receive a byte, it sends an XOFF character to notify the transmitter not to send any more data until it receives an XON character. Because this is in-band, the transmitter may not see the XOFF character immediately (it must receive and process the character), and there may be some loss if the speed is too fast. The Digital UART sends an XOFF character every time it receives a byte and sends an XON character when it is ready to receive more data. This helps minimize the potential loss of in-band signaling.

Watermark

The Digital UART contains a 64 byte buffer for Receive characters and a separate 64 byte buffer for Transmit characters. A configurable *watermark*, also known as a *trigger*, notifies the host about the position of the data at the set point, via the UART Interrupt. This

does not stop the buffer from filling beyond the watermark, it only notifies the host that the watermark level has been reached.

For example, if you only want to be notified after the receive buffer is half-filled, set the receive watermark to 32 and configure the interrupt to notify the host when the receive watermark is reached. The host will not be notified until the watermark interrupt is received, thereby freeing it up to perform other processing tasks. After the watermark interrupt is received, the host can retrieve all the bytes of received data at the same time. The receive buffer continues to fill beyond the 32 bytes and the UART interrupt remains asserted as long as there is 32 bytes or more in the buffer.

Interrupt

The Digital UART provides a separate interrupt line (output) for all the UARTs on the device. There are 8 selectable interrupts that can assert the UART interrupt line. The host can configure which interrupts are of interest. When the condition is reached, the Digital UART asserts the interrupt line (by pulling the line low) to notify the host of the condition. The host then queries the interrupt statuses for the UARTs to identify the condition(s) reached and on which UART. All interrupt conditions are maintained, even if the host has not configured to be notified of the condition. Thus, the Digital UART features the ability to poll for any interrupt condition and only be notified of selected conditions.

EEPROM

The 512 byte EEPROM is accessible via I²C communications. There are two ways to set/get the data:

- Use the commands to read, write, and erase the EEPROM, using the I²C address of 1011xxxxb (See the [Commands](#) chapter on page 15).
- Use the de facto standard of most I²C EEPROMs. This uses the address 1010xxxxb.

The EEPROM uses 32 byte pages with a total of 16 pages.

I²C EEPROM Operations

Write Operation

To write to the EEPROM, the Write Protect (WP) pin must be a digital low. The host can hold this high until ready to write, then pull low, write to the data, then pull high to continue when the writing is complete, without concern of writing EEPROM unintentionally.

Following the 7 bit address (1010xxxxb), the write bit (logic low) is sent from the master, thus completing the 8 bit packet. The slave device generates an acknowledge bit during the ninth clock cycle. The next two bytes sent by the master are the address to write the

data to. The first byte is the high byte of the word, followed by the low byte, then the data to write at that address (max of 32 bytes if the WP pin is low). When the data is complete, the master sends a stop condition, signaling the end of packet. After every byte, the slave device acknowledges the byte after it has been processed (not written). After the stop condition is received, the slave then starts the writing of the data to the EEPROM at the location specified (if the WP pin is low). The slave does not acknowledge any further requests until the write cycle is completed. The master can poll the device for completion by sending the address with the R/W bit set to a logical 0. If the cycle is in process, the slave will not acknowledge the request.

Read Operation

Read from Current Location

The master sends the start condition followed by the 7 bit address. The read bit (logic high) is sent (completing the 8 bit packet) and the slave device generates the acknowledge bit during the ninth cycle when it is ready to send. The slave then starts transmitting the bytes located at the current address pointer. After each byte is sent, the current address pointer is incremented. The address pointer rolls to 0 when incremented past max bytes. After each byte, the master sends an acknowledgement during the time it wants to continue receiving data. When the master has completed receiving the data it requires, no acknowledgement is sent; instead, the stop condition is sent, concluding the transfer.

Random Read

Random read allows data to be read from anywhere by sending an address to set the current address pointer to the beginning of the data to be read. To set the current address pointer, the master issues a start condition, followed by the 7 bit address and a write bit (logic low). The slave device acknowledges the byte and the master then sends the word address (first byte, high byte; second byte, low byte) to set the current address pointer to. The slave device acknowledges both bytes. The master then issues another start condition following the last acknowledgment, which terminates the write operation. Then the master issues the address with the read bit set and continues with the read from current location.

GPIO

The Digital UART provides up to 12 GPIO pins. Two of the GPIO pins (GPIO0, GPIO1) are able to cause the GPIO interrupt line to be asserted when the value on the input pin is toggled.

Each pin can be configured for input, output (push-pull or open drain), weak pull up resistor and de-bounce capability.

Commands

The commands identify peripherals using the high 3 bits and the lower 5 bits as the command. The EEPROM/GPIO peripheral uses 000b, UART0 uses 001b, UART1 uses 010b and System uses 111b for bits 7-5.

Command List

[Table 2](#) provides a listing of the commands and their description.

Table 2. Command List

Address (Hex)	Size (Bytes)	Direction	Peripheral	Description
0x00	1	Write	EEPROM	Write EEPROM (multiple writes in same packet allowed) ³
0x01	1	Read	EEPROM	Read EEPROM (multiple reads in same packet allowed)
0x02	2	Write	EEPROM	Write Current Location Register for EEPROM
0x03	2	Read	EEPROM	Read Current Location Register for EEPROM
0x04	1	Write	EEPROM	Erase requested Page in EEPROM
0x06	2(4) ¹	Write	GPIO	Setting GPIO Out Register
0x07	1(2) ¹	Read	GPIO	Reading GPIO In Register
0x08	3(5) ²	Write	GPIO	Write GPIO Configuration
0x09	3(5) ²	Read	GPIO	Read GPIO Configuration
0x0F	1	Read	GPIO	Read GPIO Interrupt Status Register
0x21	1	Read	UART0	Read UART Status Register
0x22	1	Write	UART0	Enable Interrupts
0x23	1	Read	UART0	Interrupt Status Register
0x24	1	Write	UART0	Write Data to TX FIFO (multiple bytes allowed) ³
0x25	1	Read	UART0	Read RX FIFO Data (Multiple Reads Allowed)
0x26	2	Write	UART0	Write Baud Rate Register
0x27	2	Read	UART0	Read Actual Baud Rate Register
0x28	2	Write	UART0	Write Configuration
0x29	2	Read	UART0	Read Configuration
0x2A	1	Write	UART0	Write Transmit Watermark Register

Table 2. Command List (Continued)

Address (Hex)	Size (Bytes)	Direction	Peripheral	Description
0x2B	1	Read	UART0	Read Transmit Watermark Register
0x2C	1	Write	UART0	Write Receive Watermark Register
0x2D	1	Read	UART0	Read Receive Watermark Register
0x2E	1	Write	UART0	Enable UART
0x31	2	Read	UART0	Read Receive and Transmit FIFO Level Registers
0x41	1	Read	UART1	Read UART Status Register
0x42	1	Write	UART1	Enable Interrupts
0x43	1	Read	UART1	Interrupt Status Register
0x44	1	Write	UART1	Write data to TX FIFO (multiple bytes allowed) ³
0x45	1	Read	UART1	Read RX FIFO data (multiple reads allowed)
0x46	2	Write	UART1	Write Baud Rate Register
0x47	2	Read	UART1	Read Actual Baud Rate Register
0x48	2	Write	UART1	Write Configuration
0x49	2	Read	UART1	Read Configuration
0x4A	1	Write	UART1	Write Transmit Watermark Register
0x4B	1	Read	UART1	Read Transmit Watermark Register
0x4C	1	Write	UART1	Write Receive Watermark Register
0x4D	1	Read	UART1	Read Receive Watermark Register
0x4E	1	Write	UART1	Enable UART
0x51	2	Read	UART1	Read Receive and Transmit FIFO Level Registers
0xE1	1	Read	SYSTEM	Read System Status Register
0xE3	1	Read	SYSTEM	Read Last Operation Result Register
0xE5	3	Read	SYSTEM	Read System Version
0xEF	1	Read	SYSTEM	Read Interrupt Source Register

Note: 1. ZDU0110QUX device uses 4 bytes, the rest uses 2 bytes.

Note: 2. Command consists of a sub-command and data. The ZDU0110QUX uses 5 bytes, the rest use 3 bytes.

Sub-command 0x0A only uses 1 byte. See Description for more information.

Note: 3. Not allowed to be stacked.

EEPROM Command Detail

Write EEPROM at Current Location

Command: 0x00

Writes data bytes at the current EEPROM memory location pointer. The bytes will continue to be written in sequential locations until either the maximum bytes have been received (up to 63 bytes) or a stop condition on the I²C was received. When the maximum bytes have been received, the Digital UART will NAK the last accepted byte transfer (and any subsequent bytes received). The WP must be low for the EEPROM to actually be written to. After receiving the stop bit on the I²C bus, the system does not acknowledge any packet until after the processing of the data is complete. The System Status Register also has the *Busy* bit set until the data has been written to the EEPROM.

Read EEPROM at Current Location

Command: 0x01

Read bytes from the EEPROM at the current EEPROM memory location pointer. The bytes will continue to be sent in sequential locations until either the NAK is received from I²C or a Stop condition is sent on the I²C bus.

Write EEPROM Current Location Register

Command: 0x02

Sets the current EEPROM memory location pointer to a specific point within the EEPROM's memory

Byte 1: High Byte of Address

Bit	7	6	5	4	3	2	1	0
Description	N/A	N/A	N/A	N/A	N/A	N/A	N/A	Addr 8

Byte 2: Low Byte of Address

Bit	7	6	5	4	3	2	1	0
Description	Addr 7	Addr 6	Addr 5	Addr 4	Addr 3	Addr 2	Addr 1	Addr 0

Read EEPROM Current Location Register

Command: 0x03

Reads the current EEPROM memory location pointer.

Read Address Format

Byte 1: High Byte of Address

Bit	7	6	5	4	3	2	1	0
Description	0	0	0	0	0	0	0	Addr 8

Byte 2: Low Byte of Address

Bit	7	6	5	4	3	2	1	0
Description	Addr 7	Addr 6	Addr 5	Addr 4	Addr 3	Addr 2	Addr 1	Addr 0

Erase EEPROM

Command: 0x04

Request to erase the EEPROM page number requested in Byte 1 (0-15).

Byte 1

Bit	7	6	5	4	3	2	1	0
Description	0	0	0	0	Page 3	Page 2	Page 1	Page 0

GPIO Command Detail

Setting GPIO Out Register

Command: 0x06

Request to set specific GPIO Out pins. The bits set in the MASK byte(s) specify the GPIO pins to be set; all others will be unchanged. If the Bit is set on the Data byte, the GPIO OUT pin will be high, otherwise it will be low (assuming the MASK bit is set). ZDU0110RxX parts only use 1 MASK byte followed by 1 Data byte.

Byte 1: GPIO Mask High

Bit	7	6	5	4	3	2	1	0
Description	N/A	N/A	N/A	N/A	GPIO11	GPIO10	GPIO9	GPIO8
Default	0	0	0	0	0	0	0	0

Byte 2: GPIO Mask Low

Bit	7	6	5	4	3	2	1	0
Description	GPIO7	GPIO6	GPIO5	GPIO4	GPIO3	GPIO2	GPIO1	GPIO0
Default	0	0	0	0	0	0	0	0

Byte 3: GPIO OUT High

Bit	7	6	5	4	3	2	1	0
Description	N/A	N/A	N/A	N/A	GPIO11	GPIO10	GPIO9	GPIO8
Default	0	0	0	0	0	0	0	0

Byte 4: GPIO OUT Low

Bit	7	6	5	4	3	2	1	0
Description	GPIO7	GPIO6	GPIO5	GPIO4	GPIO3	GPIO2	GPIO1	GPIO0
Default	0	0	0	0	0	0	0	0

Reading GPIO In Register

Command: 0x07

Reads the current value on the GPIO pins for Input. The ZDU0110QUX device sends two bytes while all other parts only send 1 byte. If the Bit is set, the GPIO pin in question is high.

Byte 1: GPIO IN High

Bit	7	6	5	4	3	2	1	0
Description	N/A	N/A	N/A	N/A	GPIO11	GPIO10	GPIO9	GPIO8
Default	0	0	0	0	0	0	0	0

Byte 2: GPIO IN Low

Bit	7	6	5	4	3	2	1	0
Description	GPIO7	GPIO6	GPIO5	GPIO4	GPIO3	GPIO2	GPIO1	GPIO0
Default	0	0	0	0	0	0	0	0

Write GPIO Configuration

Command: 0x08

This command writes specific bits to set configuration for the GPIO pins. The command is followed by a sub command, selecting the configuration in question, the mask to identify the GPIOs to be set, and the values to set. The format for the data being sent is:

Byte 0: 0x08

Byte 1: Sub Command

Byte 2-n: Data for Sub Command

Sub Commands

0x01 Set GPIO direction (Input/Output)

0x02 Enable GPIO weak Pull ups (Enable/Disable)

0x03 Enable Open Drain Mode (Enable/Disable)

0x04 Enable Debounce (Enable/Disable)

0x05 Enable Interrupt on Pin Change (Enable/Disable)

0x0A Soft Reset of GPIO to return to default settings

Set GPIO Direction (Input/Output)

Sub Command: 0x01

Sets the Input or Output direction of the GPIO pin. The bits set in the MASK byte(s) specify the GPIO pins to be set; all others will be unchanged. If the bit is set on the Data byte, the GPIO will be set to an Output pin. When cleared, the GPIO will be set to an Input pin (assuming the MASK bit is set). ZDU0110RxX parts only use 1 MASK byte followed by 1 Data byte.

Byte 2: GPIO Mask High

Bit	7	6	5	4	3	2	1	0
Description	N/A	N/A	N/A	N/A	GPIO11	GPIO10	GPIO9	GPIO8
Default	0	0	0	0	0	0	0	0

Byte 3: GPIO Mask Low

Bit	7	6	5	4	3	2	1	0
Description	GPIO7	GPIO6	GPIO5	GPIO4	GPIO3	GPIO2	GPIO1	GPIO0
Default	0	0	0	0	0	0	0	0

Byte 4: GPIO Direction High

Bit	7	6	5	4	3	2	1	0
Description	N/A	N/A	N/A	N/A	GPIO11	GPIO10	GPIO9	GPIO8
Default	0	0	0	0	0	0	0	0

Byte 5: GPIO Direction Low

Bit	7	6	5	4	3	2	1	0
Description	GPIO7	GPIO6	GPIO5	GPIO4	GPIO3	GPIO2	GPIO1	GPIO0
Default	0	0	0	0	0	0	0	0

Enable GPIO weak Pull ups (Enable/Disable)

Sub Command: 0x02

Enables or disables the weak pull up on the GPIO pin. The bits set in the MASK byte(s) specify the GPIO pins to be set; all others will be unchanged. If the bit is set on the Data byte, the weak pull up resistor on the GPIO pin will be enabled; otherwise, it will be disabled (assuming the MASK bit is set). ZDU0110RxX parts only use 1 MASK byte followed by 1 Data byte.

Byte 2: GPIO Mask High

Bit	7	6	5	4	3	2	1	0
Description	N/A	N/A	N/A	N/A	GPIO11	GPIO10	GPIO9	GPIO8
Default	0	0	0	0	0	0	0	0

Byte 3: GPIO Mask Low

Bit	7	6	5	4	3	2	1	0
Description	GPIO7	GPIO6	GPIO5	GPIO4	GPIO3	GPIO2	GPIO1	GPIO0
Default	0	0	0	0	0	0	0	0

Byte 4: GPIO Pull Up Enable/Disable High

Bit	7	6	5	4	3	2	1	0
Description	N/A	N/A	N/A	N/A	GPIO11	GPIO10	GPIO9	GPIO8
Default	0	0	0	0	0	0	0	0

Byte 5: GPIO Pull Up Enable/Disable Low

Bit	7	6	5	4	3	2	1	0
Description	GPIO7	GPIO6	GPIO5	GPIO4	GPIO3	GPIO2	GPIO1	GPIO0
Default	0	0	0	0	0	0	0	0

Enable Open Drain Mode (Enable/Disable)

Sub Command: 0x03

Enables or disables Open Drain Mode for the GPIO pin. The bits set in the MASK byte(s) specify the GPIO pins to be set, all others will be unchanged. If the bit is set on the Data byte, the GPIO pin will be placed in Open Drain (Direction must be set to Output); if the bit is cleared then Open Drain Mode will be disabled (Push-Pull when in Output mode) (assuming the MASK bit is set). ZDU0110RxX parts only use 1 MASK byte followed by 1 Data byte.

Byte 2: GPIO Mask High

Bit	7	6	5	4	3	2	1	0
Description	N/A	N/A	N/A	N/A	GPIO11	GPIO10	GPIO9	GPIO8
Default	0	0	0	0	0	0	0	0

Byte 3: GPIO Mask Low

Bit	7	6	5	4	3	2	1	0
Description	GPIO7	GPIO6	GPIO5	GPIO4	GPIO3	GPIO2	GPIO1	GPIO0
Default	0	0	0	0	0	0	0	0

Byte 4: GPIO Open Drain Mode Enable/Disable High

Bit	7	6	5	4	3	2	1	0
Description	N/A	N/A	N/A	N/A	GPIO11	GPIO10	GPIO9	GPIO8
Default	0	0	0	0	0	0	0	0

Byte 5: GPIO Open Drain Mode Enable/Disable Low

Bit	7	6	5	4	3	2	1	0
Description	GPIO7	GPIO6	GPIO5	GPIO4	GPIO3	GPIO2	GPIO1	GPIO0
Default	0	0	0	0	0	0	0	0

Enable Debounce (Enable/Disable)

Sub Command: 0x04

Enables or disables Debounce for the GPIO pin. The bits set in the MASK byte(s) specify the GPIO pins to be set; all others will be unchanged. If the bit is set on the Data byte, the GPIO pin will enable the debounce; if the bit is cleared then debounce will be disabled (assuming the MASK bit is set). ZDU0110RxX parts only use 1 MASK byte followed by 1 Data byte.

Byte 2: GPIO Mask High

Bit	7	6	5	4	3	2	1	0
Description	N/A	N/A	N/A	N/A	GPIO11	GPIO10	GPIO9	GPIO8
Default	0	0	0	0	0	0	0	0

Byte 3: GPIO Mask Low

Bit	7	6	5	4	3	2	1	0
Description	GPIO7	GPIO6	GPIO5	GPIO4	GPIO3	GPIO2	GPIO1	GPIO0
Default	0	0	0	0	0	0	0	0

Byte 4: GPIO Debounce Enable/Disable High

Bit	7	6	5	4	3	2	1	0
Description	N/A	N/A	N/A	N/A	GPIO11	GPIO10	GPIO9	GPIO8
Default	0	0	0	0	0	0	0	0

Byte 5: GPIO Debounce Enable/Disable Low

Bit	7	6	5	4	3	2	1	0
Description	GPIO7	GPIO6	GPIO5	GPIO4	GPIO3	GPIO2	GPIO1	GPIO0
Default	0	0	0	0	0	0	0	0

Enable Interrupt on Pin Change (Enable/Disable)

Sub Command: 0x05

Enables or disables the Interrupt on Pin value change for GPIO0 and/or GPIO1. The bits set in the MASK byte(s) specifies the GPIO pins to be set; all others will be unchanged. If the bit is set on the Data byte, the GPIO pin will enable the interrupt on the value being toggled, if the bit is cleared then the interrupt will be disabled (assuming the MASK bit is set).

Byte 2: GPIO Mask

Bit	7	6	5	4	3	2	1	0
Description	N/A	N/A	N/A	N/A	N/A	N/A	GPIO1	GPIO0
Default	0	0	0	0	0	0	0	0

Byte 3: GPIO Interrupt Enable/Disable

Bit	7	6	5	4	3	2	1	0
Description	N/A	N/A	N/A	N/A	N/A	N/A	GPIO1	GPIO0
Default	0	0	0	0	0	0	0	0

Soft Reset of GPIO to Return to Default Settings

Sub Command: 0x0A

Requests all GPIO pins to return to the default settings (Pull ups, Open Drain, Debounce, and Interrupt all disabled; GPIO pins set to Input).

Read GPIO Configuration

Command: 0x09

Reads the requested configuration for the GPIO pins. The command is followed by a sub command, selecting the configuration to be read.

The data is sent in the following format:

Byte 0: 0x09

Byte 1: Sub Command

Data to be read: ZDU0110QUX: 2 Bytes; ZDU0110RxX: 1 Byte

Sub Commands:

- 0x01 GPIO direction (Input/Output)
- 0x02 GPIO weak Pull ups (Enabled/Disabled)
- 0x03 Open Drain Mode (Enabled/Disabled)
- 0x04 Debounce (Enabled/Disabled)
- 0x05 Interrupt on Pin Change (Enabled/Disabled)

GPIO Direction

Sub Command: 0x01

Reads the current setting for the GPIO direction. If the bit is set, the pin is configured for output; otherwise, it is configured for input.

Return Byte 1: GPIO Direction High

Bit	7	6	5	4	3	2	1	0
Description	N/A	N/A	N/A	N/A	GPIO11	GPIO10	GPIO9	GPIO8
Default	0	0	0	0	0	0	0	0

Return Byte 2: GPIO Direction Low

Bit	7	6	5	4	3	2	1	0
Description	GPIO7	GPIO6	GPIO5	GPIO4	GPIO3	GPIO2	GPIO1	GPIO0
Default	0	0	0	0	0	0	0	0

GPIO Weak Pull Ups

Sub Command: 0x02

Reads the current setting for the GPIO pull-ups. If the bit is set, the pin has the pull-up resistor enabled; otherwise it is disabled.

Return Byte 1: GPIO Pull-up High

Bit	7	6	5	4	3	2	1	0
Description	N/A	N/A	N/A	N/A	GPIO11	GPIO10	GPIO9	GPIO8
Default	0	0	0	0	0	0	0	0

Return Byte 2: GPIO Pull-up Low

Bit	7	6	5	4	3	2	1	0
Description	GPIO7	GPIO6	GPIO5	GPIO4	GPIO3	GPIO2	GPIO1	GPIO0
Default	0	0	0	0	0	0	0	0

Open Drain Mode

Sub Command: 0x03

Reads the current setting for the GPIO Open Drain Mode. If the bit is set, the GPIO pin is in the Open Drain mode.

Return Byte 1: GPIO Open Drain Mode High

Bit	7	6	5	4	3	2	1	0
Description	N/A	N/A	N/A	N/A	GPIO11	GPIO10	GPIO9	GPIO8
Default	0	0	0	0	0	0	0	0

Return Byte 2: GPIO Open Drain Mode Low

Bit	7	6	5	4	3	2	1	0
Description	GPIO7	GPIO6	GPIO5	GPIO4	GPIO3	GPIO2	GPIO1	GPIO0
Default	0	0	0	0	0	0	0	0

Debounce

Sub Command: 0x04

Reads the current setting for the GPIO Debounce. If the bit is set, the GPIO pin has the Debounce feature enabled.

Return Byte 1: GPIO Debounce High

Bit	7	6	5	4	3	2	1	0
Description	N/A	N/A	N/A	N/A	GPIO11	GPIO10	GPIO9	GPIO8
Default	0	0	0	0	0	0	0	0

Return Byte 2: GPIO Debounce Low

Bit	7	6	5	4	3	2	1	0
Description	GPIO7	GPIO6	GPIO5	GPIO4	GPIO3	GPIO2	GPIO1	GPIO0
Default	0	0	0	0	0	0	0	0

Interrupt on Pin Change

Sub Command: 0x05

Reads the current setting for interrupt notification on pin change. If the bit is set, any change on the pin will cause the Interrupt line to be asserted.

Return Byte 1: GPIO Interrupt

Bit	7	6	5	4	3	2	1	0
Description	N/A	N/A	N/A	N/A	N/A	N/A	GPIO1	GPIO0
Default	0	0	0	0	0	0	0	0

Read GPIO Interrupt Status Register

Command: 0x0F

Identifies which GPIO interrupted on Port Change. If set, an interrupt occurred; if cleared, there is no interrupt. Register is cleared (and interrupt is released) when read.

Return Byte 1: GPIO Interrupt

Bit	7	6	5	4	3	2	1	0
Description	N/A	N/A	N/A	N/A	N/A	N/A	GPIO1	GPIO0
Default	0	0	0	0	0	0	0	0

UART Command Detail

Read UART Status Register

Command: UART0: 0x21; **UART1:** 0x41

Retrieves the status of the UART packets and information. Reading this register will clear the errors (bits 0-3).

Bit	7	6	5	4	3	2	1	0
	TX Empty	TX Full	RX Data	N/A	Break	DOR	FE	PE
Description								

TX Empty: Transmit buffer is empty if set

TX Full: Transmit buffer is full if set

RX Empty: Receive buffer has data if set

Break: Break received

DOR: Data over run error if set

FE: Frame error if set

PE: Parity error if set

Enable Interrupts

Command: UART0: 0x22; **UART1:** 0x42

When the bit is set, the system will assert the Interrupt line when the condition is met.

Bit	7	6	5	4	3	2	1	0
	TX Empty	TX Watermark	TK Full	Break	RX Data	TX Watermark	RX Full	TX/RX Error
Description								
Default	0	0	0	0	0	0	0	0

TX Empty: Transmit buffer is empty if set

TX Full: Transmit buffer is full if set

RX Empty: Receive buffer has data if set

Break: Break received

DOR: Data over run error if set

FE: Frame error if set

PE: Parity error if set

Interrupt Status Register

Command: UART0: 0x23; **UART1:** 0x43

When the bit is set, the condition has been met. Reading this register will clear the TX/RX Error Interrupt.

Bit	7	6	5	4	3	2	1	0
Description	TX Empty	TX Watermark	TK Full	N/A	RX Data	RX Watermark	RX Full	TX/RX Error

TX Empty: Transmit buffer is Empty

TX Watermark: The watermark for the Transmit has been reached

TX Full: The Transmit buffer is full

RX Data: The Receive Buffer has data

RX Watermark: The Receive Buffer has passed the watermark level

RX Full: The Receive Buffer is full

TX/RX Error: The UART has received an error (check status for which one)

Write Data to TX FIFO

Command: UART0: 0x24; **UART1:** 0x44

Writes all bytes received to TX FIFO until the packet is terminated or TX Buffer is full. I²C terminates by Stop condition. If the buffer is full, the I²C transmits a Negative Acknowledgement (NAK) for any byte sent until the buffer has been emptied enough to take more data. Any byte that has been NAK'd is not added to the buffer.

Byte 1 Through Byte n

Bit	7	6	5	4	3	2	1	0
Description	Data7	Data6	Data5	Data4	Data3	Data2	Data1	Data0

Read RX FIFO Data

Command: UART0: 0x25; **UART1:** 0x45

Reads bytes from the RX FIFO until either a Stop Condition or a NAK is received. If the reads exceed the number of bytes in the FIFO, the returning value will be 0x00.

Byte 1 Through Byte n

Bit	7	6	5	4	3	2	1	0
Description	Data7	Data6	Data5	Data4	Data3	Data2	Data1	Data0

Write Baud Rate Register

Command: UART0: 0x26; **UART1:** 0x46

Sets the baud rate for the requested UART, in multiples of 100.

► **Note:** For more information about the baud rate, see [UART](#) on page 11.

Byte 1: Baud Rate (in 100s) High

Bit	7	6	5	4	3	2	1	0
Description	B15	B14	B13	B12	B11	B10	B9	B8

Byte 2: Baud Rate (in 100s) Low

Bit	7	6	5	4	3	2	1	0
Description	B7	B6	B5	B4	B3	B2	B1	B0

Read Actual Baud Rate Register

Command: UART0: 0x27; **UART1:** 0x47

Reads the actual baud rate in the baud rate register (in multiple of 100s).

► **Note:** For more information about the baud rate, see [UART](#) on page 11.

Byte 1: Baud Rate (in 100s) High

Bit	7	6	5	4	3	2	1	0
Description	B15	B14	B13	B12	B11	B10	B9	B8

Byte 2: Baud Rate (in 100s) Low

Bit	7	6	5	4	3	2	1	0
Description	B7	B6	B5	B4	B3	B2	B1	B0

Write Configuration

Command: UART0: 0x28; **UART1:** 0x48

The configuration for the UART can either be set with all parameters in one command or individual parameters, by the use of sub commands. The first byte, bit 7, determines if this is a sub command request or data (configuring all parameters). If the bit 7 is cleared, the data is a sub command; otherwise, the data is all configuration parameters. The sub commands also provides the ability to reset the FIFO buffers and a soft reset of the UART to return to default settings.

Setting All Parameters At Once

2 bytes are required to provide all the parameters at once. Bit 7 of Byte 1 **MUST** be set.

Byte 1: Bit 7 is Set

Bit	7	6	5	4	3	2	1	0
Description	Cmd	N/A	Parity1	Parity0	Databits2	Databits1	Databits0	StopBits
Default Config	1	0	0	0	0	1	1	0

Parity:

- 00 None
- 11 Odd
- 10 Even

Data Bits:

- 000 5 bit data
- 001 6 bit data
- 010 7 bit data
- 011 8 bit data
- 111 9 bit data

Stop Bit:

- 0 1 stop bit
- 1 2 stop bits

Byte 2:

Bit	7	6	5	4	3	2	1	0
Description	N/A	N/A	TXE	RXE	Loopback	FlowControl1	FlowControl0	N/A
Default	0	0	0	0	0	0	0	0

TXE:

- 0 Disable TX
- 1 Enable TX

RXE:

- 0 Disable RX
- 1 Enable RX

Loopback:

- 0 Disable Loopback mode
- 1 Enable Loopback mode

Flow Control:

- 00 None
- 01 Hardware (CTS/RTR)
- 10 Software (Xon/Xoff)

Setting Individual Parameters

To set individual parameters for the UART configuration, the system requires two bytes – the sub command byte and the data byte. Bit 7 of the sub command byte **MUST** be cleared.

Sub Commands:

- 0x01 Set databits
- 0x02 Set Parity
- 0x03 Set Stop bits
- 0x04 Set Flow Control
- 0x05 Reserved
- 0x06 Reset FIFOs
- 0x07 Reserved
- 0x08 Set Loopback
- 0x0A Soft Reset of UART to return to default settings

Set Data Bits

Sub Command 0x01

Byte 2 – Data Bits

Bit	7	6	5	4	3	2	1	0
Description	N/A	N/A	N/A	N/A	N/A	Databits2	Databits1	Databits0
Default	0	0	0	0	0	0	0	0

Data Bits:

000 5 bit data
 001 6 bit data
 010 7 bit data
 011 8 bit data
 111 9 bit data

Set Parity

Sub Command 0x02

Byte 2 – Parity

Bit	7	6	5	4	3	2	1	0
Description	N/A	N/A	N/A	N/A	N/A	N/A	Parity1	Parity2
Default	0	0	0	0	0	0	0	0

Parity:

00 None
 11 Odd
 10 Even

Set Stop Bits

Sub Command 0x03

Byte 2 – Stop Bits

Bit	7	6	5	4	3	2	1	0
Description	N/A	N/A	N/A	N/A	N/A	N/A	N/A	Stop Bit
Default	0	0	0	0	0	0	0	0

Stop Bits:
0 1 stop bit
1 2 stop bit

Set Flow Control

Sub Command 0x04

Byte 2 – Flow Control

Bit	7	6	5	4	3	2	1	0
Description	N/A	N/A	N/A	N/A	N/A	N/A	FlowControl1	FlowControl2
Default	0	0	0	0	0	0	0	0

Flow Control:
00 None
01 Hardware (CTS/RTR)
10 Software (Xon/Xoff)

Reset FIFOs

Sub Command 0x06

Byte 2 – Reset FIFOs

Bit	7	6	5	4	3	2	1	0
Description	N/A	N/A	N/A	N/A	N/A	N/A	RX FIFO	TX FIFO
Default	0	0	0	0	0	0	0	0

Reset FIFO:
TXFIFO:
0 Do not reset
1 Reset TX FIFO
RXFIFO:
0 Do not reset
1 Reset RX FIFO

Set Loopback

Sub Command 0x08

Byte 2 – Loopback

Bit	7	6	5	4	3	2	1	0
Description	N/A	N/A	N/A	N/A	N/A	N/A	N/A	Loopback
Default	0	0	0	0	0	0	0	0

Loopback:

0 - Loopback Off (normal operations)

1 - Loopback On

Reset UART

Sub Command 0x0A

This command does a soft reset for the UART and returns back to default conditions. No data is to be sent with this sub command.

Read Configuration

Command: UART0: 0x29; **UART1:** 0x49

Reads the current configuration of the UART

Byte 1 Returned:

Bit	7	6	5	4	3	2	1	0
Description	N/A	N/A	Parity1	Parity0	Databits2	Databits1	Databits0	StopBits
Default	0	0	0	0	0	1	1	0

Parity:

00 None

11 Odd

10 Even

Data Bits:

000 5 bit data

001 6 bit data

010 7 bit data

011 8 bit data

111 9 bit data

Stop bit:

- 0 1 stop bit
- 1 2 stop bits

Byte 2 Returned:

Bit	7	6	5	4	3	2	1	0
Description	N/A	N/A	TXE	RXE	Loopback	FlowControl1	FlowControl0	N/A
Default	0	0	0	0	0	0	0	0

TXE:

- 0 Disable TX
- 1 Enable TX

RXE:

- 0 Disable RX
- 1 Enable RX

Loopback:

- 0 Disable Loopback mode
- 1 Enable Loopback mode

Flow Control:

- 00 None
- 01 Hardware (CTS/RTR)
- 10 Software (Xon/Xoff)

Write Transmit Watermark Register

Command: UART0: 0x2A; **UART1:** 0x4A

Writes the Transmit Watermark Register.

Values between 1 and 64 are acceptable. Sending a 0x00 will keep the TX Watermark Interrupt always on and any value greater than 64 will not ever set the Interrupt. The default value is 63.

Read Transmit Watermark Register

Command: UART0: 0x2B; **UART1:** 0x4B

Reads the Transmit Watermark Register.

Write Receive Watermark Register

Command: UART0: 0x2C; **UART1:** 0x4C

Writes the Receive Watermark Register.

Values between 1 and 64 are acceptable. Sending a 0x00 value will keep the RX Watermark Interrupt always on and any value greater than 64 will never set the Interrupt. The default value is 1.

Read Receive Watermark Register

Command: UART0: 0x2D; **UART1:** 0x4D

Reads the Receive Watermark Register.

Enable UART

Command: UART0: 0x2E; **UART1:** 0x4E

Enables the UART for receiving and/or transmitting.

Byte 1: Enable UART RX and TX

Bit	7	6	5	4	3	2	1	0
Description	N/A	N/A	N/A	N/A	N/A	N/A	TXE	RXE

TXE:

- 0 Disable TX
- 1 Enable TX

RXE:

- 0 Disable RX
- 1 Enable RX

Read Receive and Transmit FIFO Level Registers

Command: UART0: 0x31; **UART1:** 0x51

Retrieves the current FIFO level for the Receive and Transmit FIFOs.

The maximum value is 64 and the minimum value is 0.

Byte 1: RX FIFO Level

Bit	7	6	5	4	3	2	1	0
Description	N/A	N/A	Level5	Level4	Level3	Level2	Level1	Level0
Default	0	0	0	0	0	0	0	0

Byte 2: TX FIFO Level

Bit	7	6	5	4	3	2	1	0
Description	N/A	N/A	Level5	Level4	Level3	Level2	Level1	Level0
Default	0	0	0	0	0	0	0	0

System Command Detail

Read System Status Register

Command: 0xE1

Provides the status of the system.

Byte 1: Status

Bit	7	6	5	4	3	2	1	0
Description	Init	N/A	N/A	N/A	N/A	N/A	Op Error	Busy

Init: When set, the system is being initialized. When cleared, the system is operational.

Busy: When set, the system is busy processing a request.

Op Error: When not busy, sets the bit if there was an error on the last register write operation performed.

► **Note:** If the system is busy processing a write request, the system will NAK any request, including the System Status Register, until the write request is completed.

Read Last Operation Result Register

Command: 0xE3

This command provides the operational result for the last command request. A 0x00 value indicates success and a non-zero value indicates an error.

Read System Version

Command: 0xE5

Reads the version of the Digital UART part.

Byte 1: Part Identifier (1-99)

Bit	7	6	5	4	3	2	1	0
Description	Bit 7	Bit 6	Bit 5	Bit 4	Bit 3	Bit 2	Bit 1	Bit 0

Byte 2: Major Revision (1-99)

Bit	7	6	5	4	3	2	1	0
Description	Bit 7	Bit 6	Bit 5	Bit 4	Bit 3	Bit 2	Bit 1	Bit 0

Byte 1: Minor Revision (0-99)

Bit	7	6	5	4	3	2	1	0
Description	Bit 7	Bit 6	Bit 5	Bit 4	Bit 3	Bit 2	Bit 1	Bit 0

Read Interrupt Source Register

Command: 0xEF

Provides the source of any active interrupt. Used to quickly identify which peripheral has requested the interrupt when there is more than one peripheral on a single interrupt line, such as the UART.

Byte 1: Source

Bit	7	6	5	4	3	2	1	0
Description	N/A	N/A	N/A	N/A	N/A	U1	U0	GPIO
Default	0	0	0	0	0	0	0	0

U1: External UART1 - Interrupt on the UART1 (if available)

U0: External UART0 - Interrupt on the UART0

GPIO: GPIO – Interrupt on GPIO pin toggle

Electrical Characteristics

This chapter lists the electrical characteristics of the Digital UART.

Absolute Maximum Ratings

Parameter	Symbol	Rating	Unit	
Supply Voltage	VDD	-0.3 ~ +6.5	V	
	VSS	-0.3 ~ +0.3	V	
Normal Voltage Pin	VI	-0.3 ~ VDD+0.3	V	
	VO	-0.3 ~ VDD+0.3	V	
	IOH	10	mA	
	Σ IOH	80	mA	
	IOL	20	mA	
	Σ IOL	160	mA	
	Total Power Dissipation	PT	600	mW
	Storage Temperature	TSTG	-45~+125	°C

Note: Stresses beyond those listed under “Absolute Maximum Ratings” may cause permanent damage to the device. This is a stress rating only and functional operation of the device at any other conditions beyond those indicated in the operational sections of this specification is not implied. Exposure to absolute maximum rating conditions for extended periods may affect device reliability.

Recommended Operating Conditions

Parameter	Symbol	Condition	Minimum	Typical	Maximum	Unit
Supply Voltage	VDD		1.8		5.5	V
Operating Temperature	TOPR	VDD=1.8~5.5V	-40		85	°C
Operating Frequency			7.76		8.24	MHz
				1		MHz

Power-on Reset Characteristics

Parameter	Symbol	Condition	Minimum	Typical	Maximum	Unit
Operating Voltage		-	VSS	-	5.5	V
Operating Temperature		-	-40		85	°C
RESET Release Level		-	1.3	1.4	1.5	V
nRESET Input Pulse "L" Width	tRST	VDD=5.0V	1.1	-	-	µs
Operating Current	IDD	-	-	-	10	µA
	SIDD	-	-	-	1	µA

Internal RC Oscillator Characteristics

Parameter	Symbol	Condition	Minimum	Typical	Maximum	Unit
Operating Voltage		–	1.8	–	5.5	V
Operating Temperature		–	–40		85	°C
Frequency		–	7.76		8.24	MHz
Stabilization Time		–	–	–	10	mS
Operating Current	IDD	–	–	–	–	uA
	SIDD	–	–	–	1	uA

DC Characteristics

Parameter	Symbol	Condition	Minimum	Typical	Maximum	Unit
Input Low Voltage	VIL	–	–0.5	–	0.2VDD	V
Input High Voltage	VIH	–	0.7VDD	–	VDD	V
Output Low Voltage	VOL	IOL=20mA, Vdd=4.5V	–	–	1	V
Output High Voltage	VOH	IOH=8.57mA, VDD=4.5V	3.5	–	–	V
Input High Leakage Current	IIH				1	uA
Input Low Leakage Current	IIL		–1			uA
Pull-up Resistor	RPU		20		50	kΩ
Power Supply Current	IDD	VDD=5V, All GPIO OUT low	–	2.6	–	mA

Packaging

Figure 6.32-Pin QFN Package

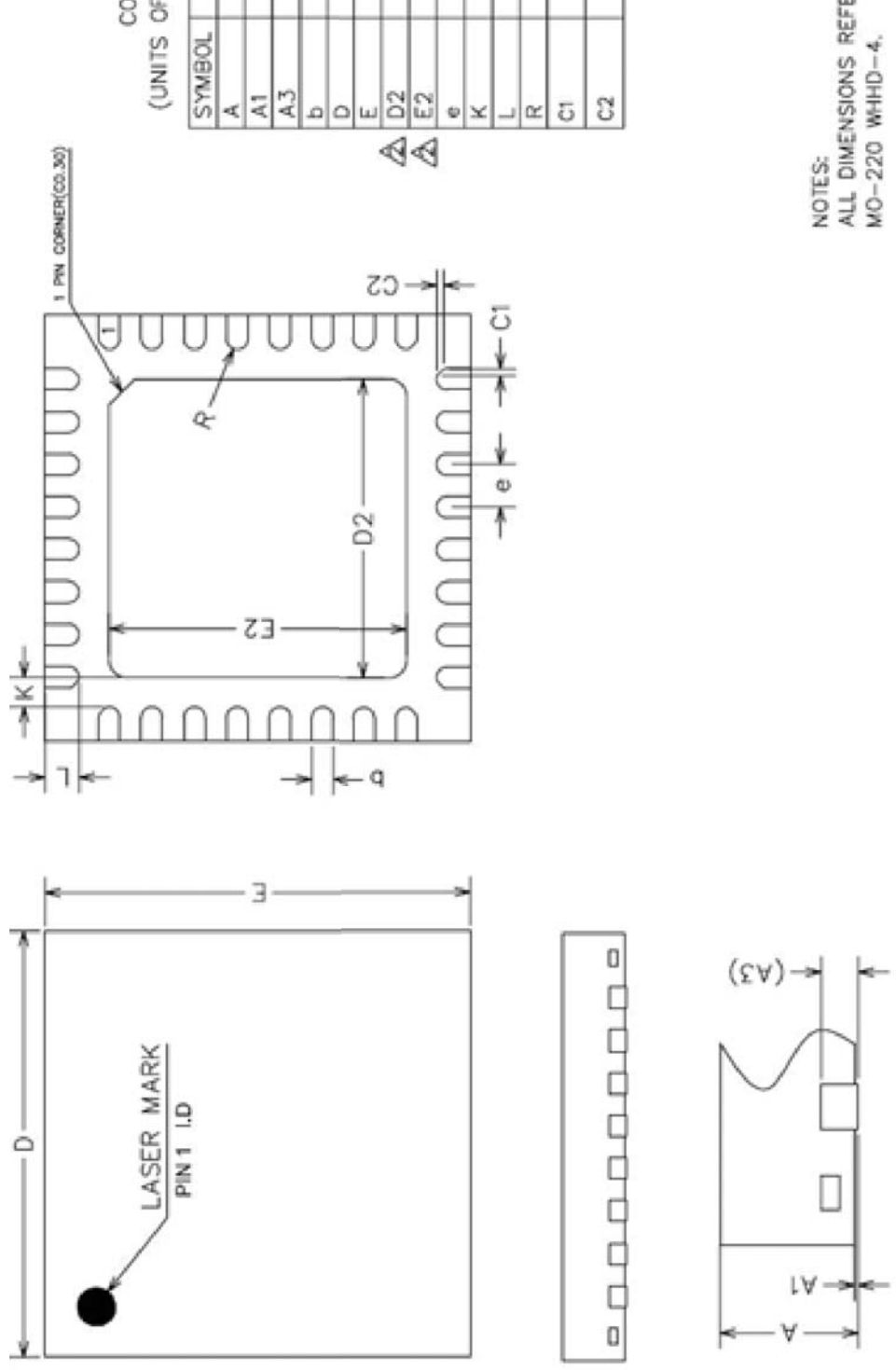

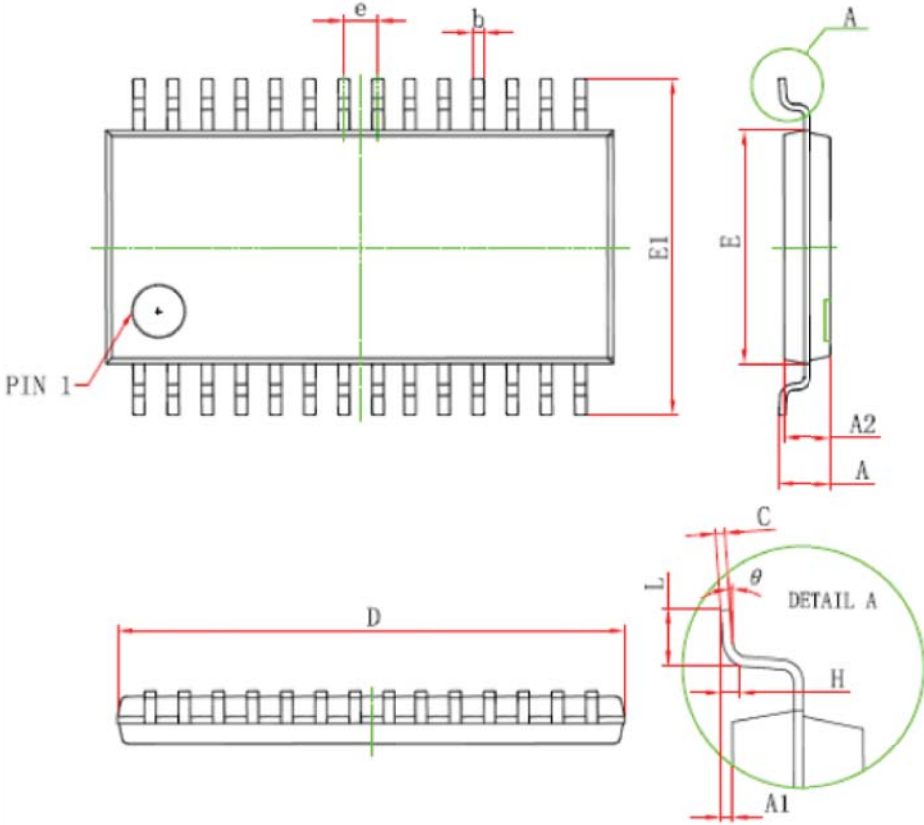

Symbol	Dimensions In Millimeters		Dimensions In Inches	
	Min	Max	Min	Max
D	9.600	9.800	0.378	0.386
E	4.300	4.500	0.169	0.177
b	0.190	0.300	0.007	0.012
c	0.090	0.200	0.004	0.008
E1	6.250	6.550	0.246	0.258
A		1.200		0.047
A2	0.800	1.000	0.031	0.039
A1	0.050	0.150	0.002	0.006
e	0.65 (BSC)		0.026 (BSC)	
L	0.500	0.700	0.020	0.028
H	0.25(TYP)		0.01(TYP)	
θ	1°	7°	1°	7°

Figure 7. 28-Pin TSSOP Package

Figure 8.20-Pin TSSOP Package

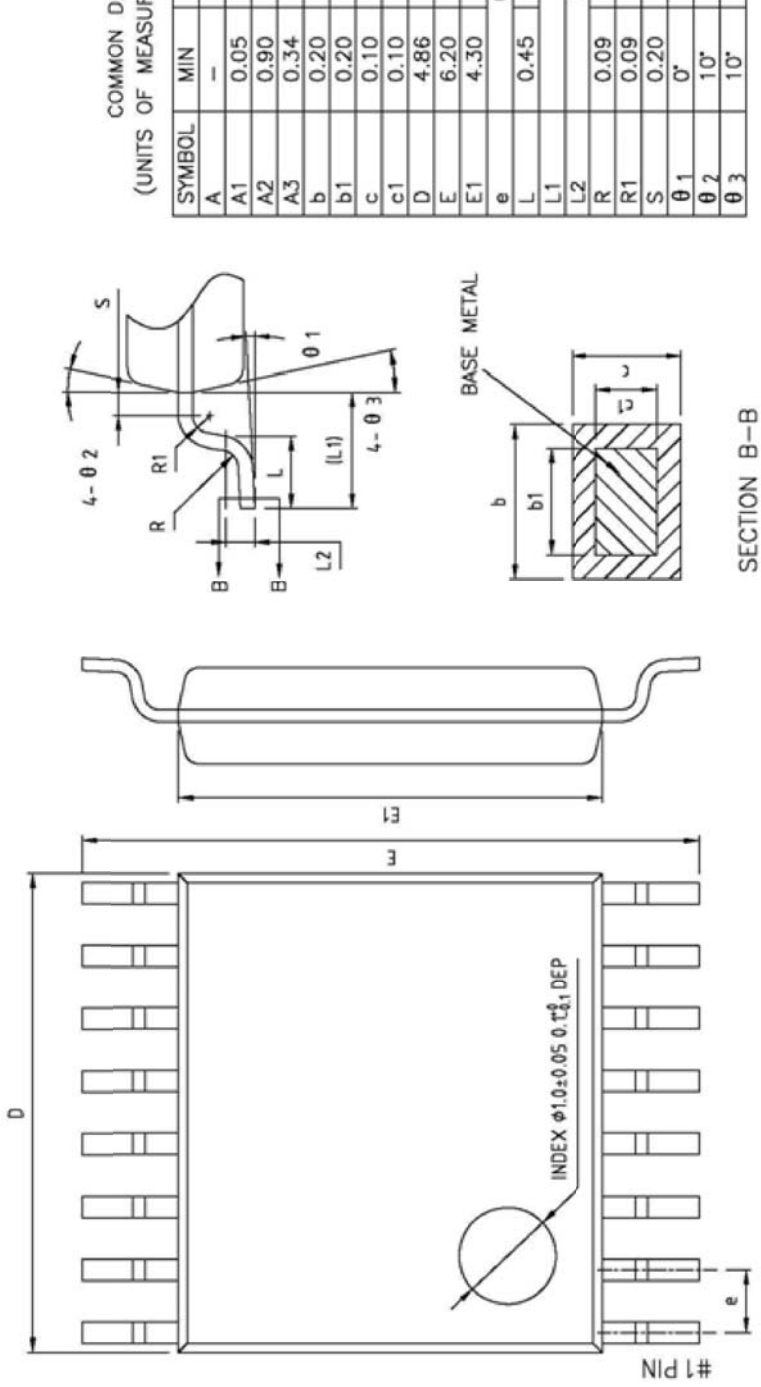

COMMON DIMENSIONS
(UNITS OF MEASUREMENT)

SYMBOL	MIN
A	—
A1	0.05
A2	0.90
A3	0.34
b	0.20
b1	0.20
c	0.10
c1	0.10
D	4.86
E	6.20
E1	4.30
e	—
L	0.45
L1	—
L2	—
R	0.09
R1	0.09
S	0.20
$\theta 1$	0°
$\theta 2$	10°
$\theta 3$	10°

NOTES:
ALL DIMENSIONS REFER TO JEDEC STANDARD
DO NOT INCLUDE MOLD FLASH OR PROTRUSION

Figure 9.16-16-Pin TSSOP Package

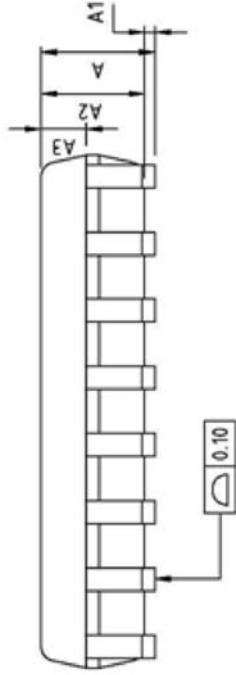
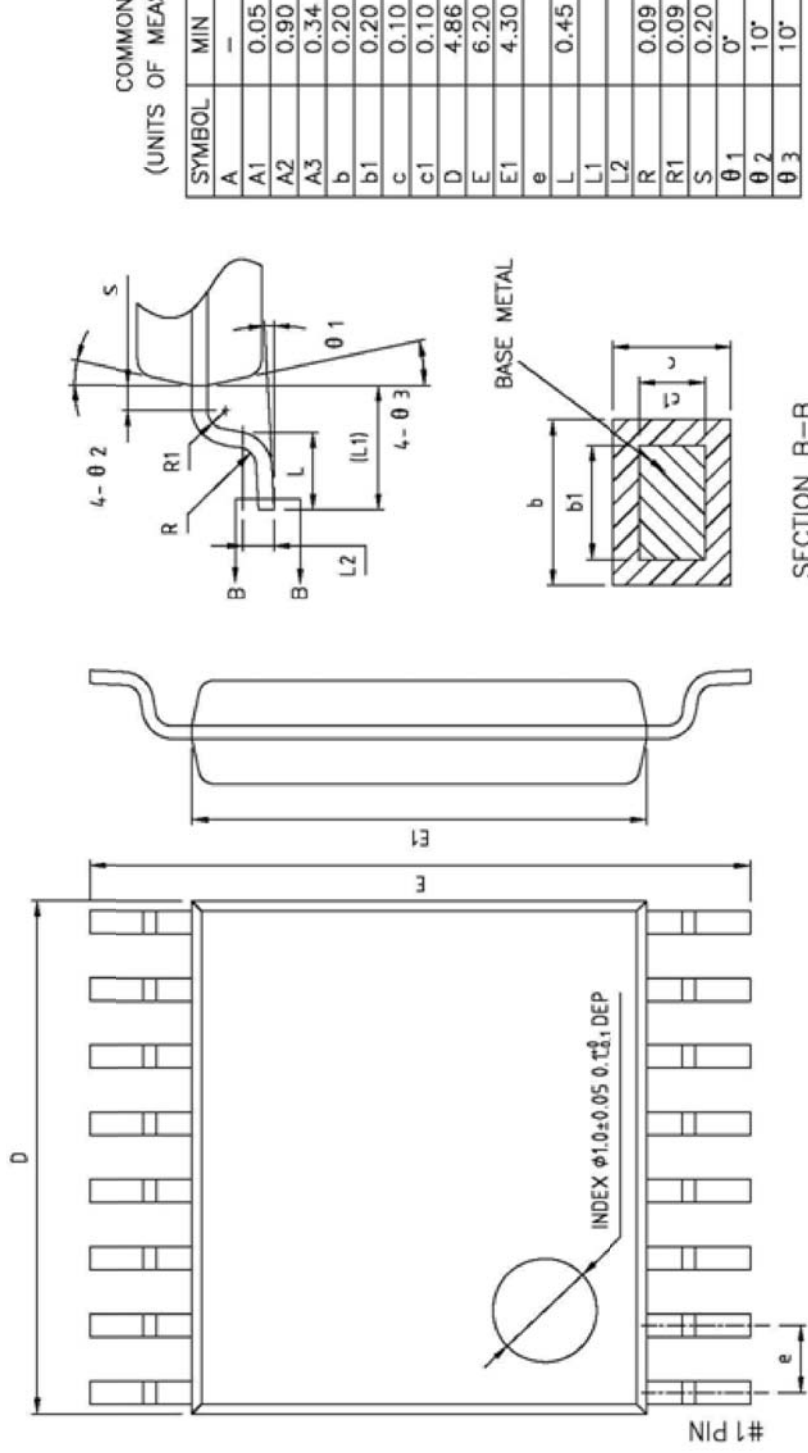

NOTES:
ALL DIMENSIONS REFER TO JEDEC STANDARD
DO NOT INCLUDE MOLD FLASH OR PROTRUSION

Ordering Information

[Table 3](#) identifies the basic features and package styles available for the Digital UART.

Table 3. Ordering Information

Part Number	UARTs	GPIOs	Package
ZDU0110RFX	1	3	16 pin TSSOP
ZDU0110RHX	1	7	20 pin TSSOP
ZDU0210RJX	2	8	28 pin TSSOP
ZDU0210QUX	2	12	32 pin QFN

Customer Support

To share comments, get your technical questions answered, or report issues you may be experiencing with our products, please visit Zilog's Technical Support page at <http://support.zilog.com>.

To learn more about this product, find additional documentation, or to discover other facets about Zilog product offerings, please visit the Zilog Knowledge Base at <http://zilog.com/kb> or consider participating in the Zilog Forum at <http://zilog.com/forum>.

This publication is subject to replacement by a later edition. To determine whether a later edition exists, please visit the Zilog website at <http://www.zilog.com>.

Looking for pricing, stock, or lifecycle information?

Click below to explore more details on WIN SOURCE:

 [View ZDU0110RFX](#) on WIN SOURCE

 [Zilog](#) Information

Optimize Your Supply Chain with WIN SOURCE Solutions

-  Global Sourcing Solution
-  Obsolete Management
-  Cost Control Management
-  Shortage Management
-  Alternative Solution
-  Excess Inventory Management