



# PIC24FJ256GA110 FAMILY

## 64/80/100-Pin, 16-Bit, General Purpose Flash Microcontrollers with Peripheral Pin Select (PPS)

### Power Management:

- On-Chip 2.5V Voltage Regulator
- Switch between Clock Sources in Real Time
- Idle, Sleep and Doze modes with Fast Wake-up and Two-Speed Start-up
- Run mode: 1 mA/MIPS, 2.0V Typical
- Standby Current with 32 kHz Oscillator: 2.6  $\mu$ A, 2.0V Typical

### High-Performance CPU:

- Modified Harvard Architecture
- Up to 16 MIPS Operation at 32 MHz
- 8 MHz Internal Oscillator
- 17-Bit x 17-Bit Single-Cycle Hardware Multiplier
- 32-Bit by 16-Bit Hardware Divider
- 16 x 16-Bit Working Register Array
- C Compiler Optimized Instruction Set Architecture with Flexible Addressing modes
- Linear Program Memory Addressing, Up to 12 Mbytes
- Linear Data Memory Addressing, Up to 64 Kbytes
- Two Address Generation Units (AGUs) for Separate Read and Write Addressing of Data Memory

### Analog Features:

- 10-Bit, Up to 16-Channel Analog-to-Digital (A/D) Converter at 500 ksp/s:
  - Conversions available in Sleep mode
- Three Analog Comparators with Programmable Input/Output Configuration
- Charge Time Measurement Unit (CTMU)

### Peripheral Features:

- Peripheral Pin Select:
  - Allows independent I/O mapping of many peripherals at run time
  - Continuous hardware integrity checking and safety interlocks prevent unintentional configuration changes
  - Up to 46 available pins (100-pin devices)
- Three 3-Wire/4-Wire SPI modules (support 4 Frame modes) with 8-Level FIFO Buffer
- Three I<sup>2</sup>C modules support Multi-Master/Slave modes and 7-Bit/10-Bit Addressing
- Four UART modules:
  - Supports RS-485, RS-232, LIN/J2602 protocols and IrDA<sup>®</sup>
  - On-chip hardware encoder/decoder for IrDA
  - Auto-wake-up and Auto-Baud Detect (ABD)
  - 4-level deep FIFO buffer
- Five 16-Bit Timers/Counters with Programmable Prescaler
- Nine 16-Bit Capture Inputs, each with a Dedicated Time Base
- Nine 16-Bit Compare/PWM Outputs, each with a Dedicated Time Base
- 8-Bit Parallel Master Port (PMP/PSP):
  - Up to 16 address pins
  - Programmable polarity on control lines
- Hardware Real-Time Clock/Calendar (RTCC):
  - Provides clock, calendar and alarm functions
- Programmable Cyclic Redundancy Check (CRC) Generator
- Up to Five External Interrupt Sources

Devices	Pins	Program Memory (Bytes)	SRAM (Bytes)	Remappable Peripherals						i <sup>2</sup> C	10-Bit A/D (ch)	Comparators	PMP/PSP	JTAG	CTMU
				Remappable Pins	Timers 16-Bit	Capture Input	Compare/PWM Output	UART w/ IrDA <sup>®</sup>	SPI						
PIC24FJ64GA106	64	64K	16K	31	5	9	9	4	3	3	16	3	Y	Y	Y
PIC24FJ128GA106	64	128K	16K	31	5	9	9	4	3	3	16	3	Y	Y	Y
PIC24FJ192GA106	64	192K	16K	31	5	9	9	4	3	3	16	3	Y	Y	Y
PIC24FJ256GA106	64	256K	16K	31	5	9	9	4	3	3	16	3	Y	Y	Y
PIC24FJ64GA108	80	64K	16K	42	5	9	9	4	3	3	16	3	Y	Y	Y
PIC24FJ128GA108	80	128K	16K	42	5	9	9	4	3	3	16	3	Y	Y	Y
PIC24FJ192GA108	80	192K	16K	42	5	9	9	4	3	3	16	3	Y	Y	Y
PIC24FJ256GA108	80	256K	16K	42	5	9	9	4	3	3	16	3	Y	Y	Y
PIC24FJ64GA110	100	64K	16K	46	5	9	9	4	3	3	16	3	Y	Y	Y
PIC24FJ128GA110	100	128K	16K	46	5	9	9	4	3	3	16	3	Y	Y	Y
PIC24FJ192GA110	100	192K	16K	46	5	9	9	4	3	3	16	3	Y	Y	Y
PIC24FJ256GA110	100	256K	16K	46	5	9	9	4	3	3	16	3	Y	Y	Y

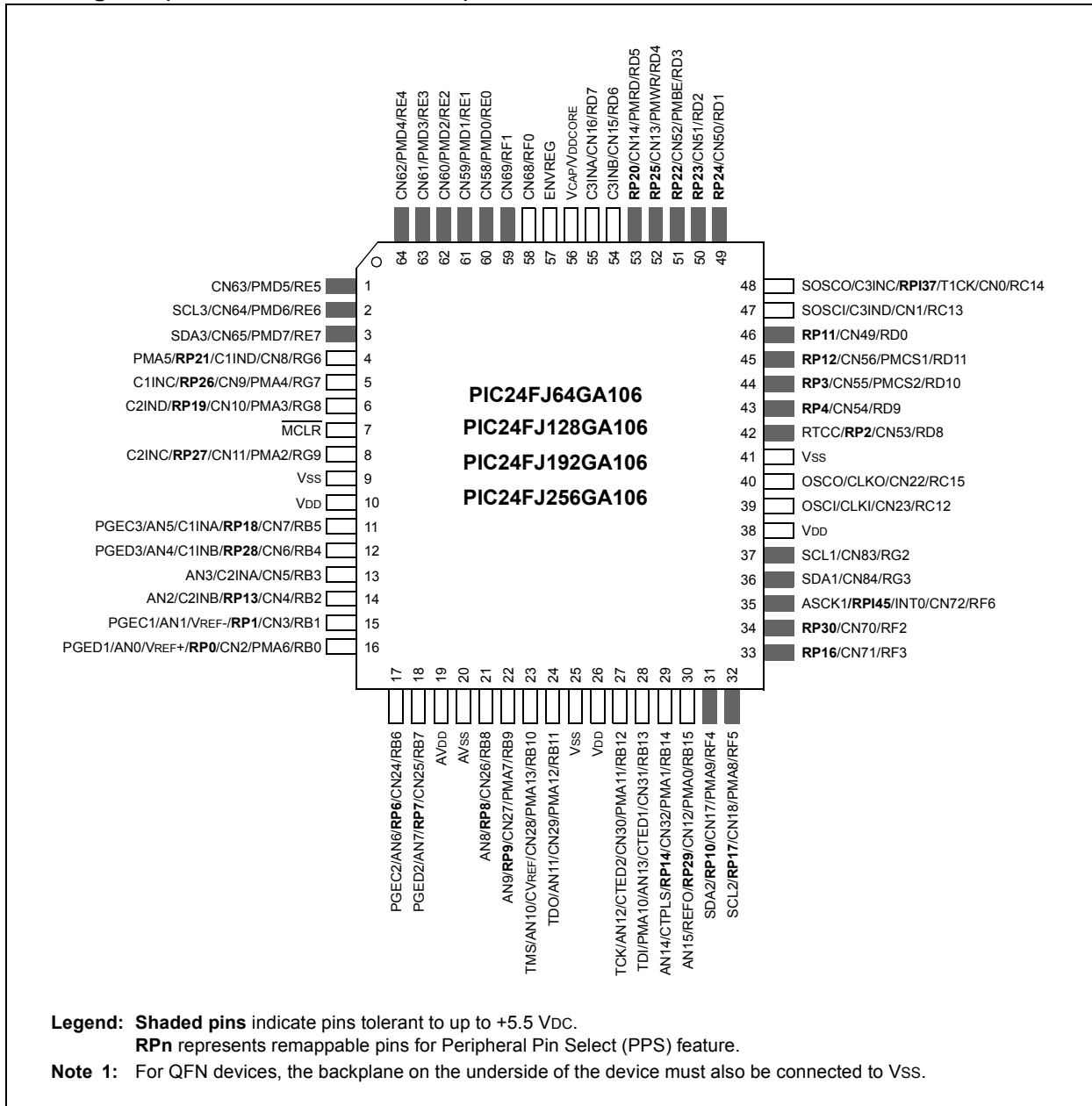
# PIC24FJ256GA110 FAMILY

## Special Microcontroller Features:

- Operating Voltage Range of 2.0V to 3.6V
- Self-Reprogrammable under Software Control
- 5.5V Tolerant Input (digital pins only)
- Configurable Open-Drain Outputs on Digital I/Os
- High-Current Sink/Source (18 mA/18 mA) on all I/Os
- Selectable Power Management modes:
  - Sleep, Idle and Doze modes with fast wake-up
- Fail-Safe Clock Monitor Operation:
  - Detects clock failure and switches to on-chip FRC oscillator
- On-Chip LDO Regulator

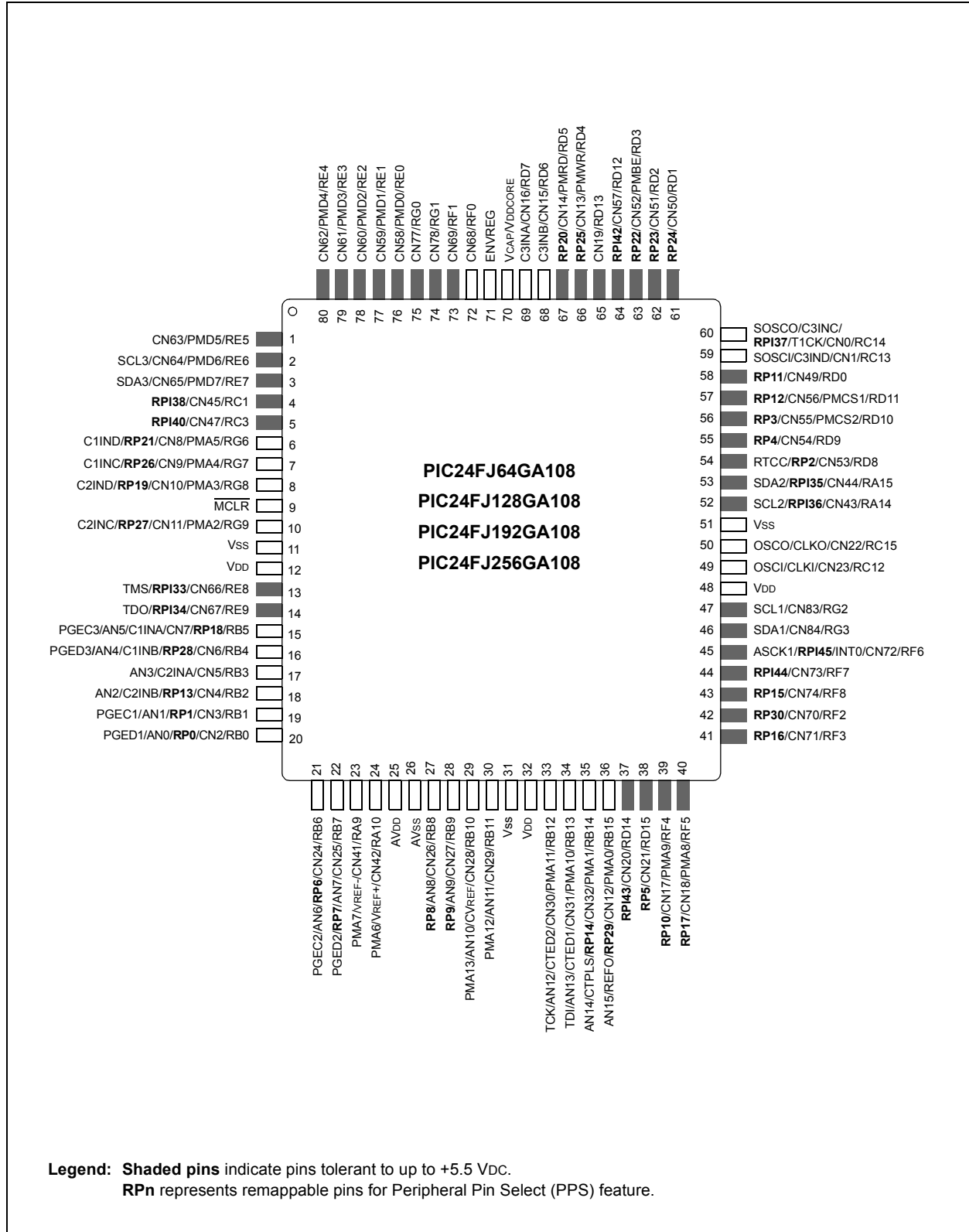
- Power-on Reset (POR), Power-up Timer (PWRT), Low-Voltage Detect (LVD) and Oscillator Start-up Timer (OST)
- Flexible Watchdog Timer (WDT) with On-Chip Low-Power RC Oscillator for Reliable Operation
- In-Circuit Serial Programming™ (ICSP™) and In-Circuit Debug (ICD) via Two Pins
- JTAG Boundary Scan Support
- Brown-out Reset (BOR)
- Flash Program Memory:
  - 10,000 erase/write cycle endurance (minimum)
  - 20-year data retention minimum
  - Selectable write protection boundary
  - Write protection option for Flash Configuration Words

## Pin Diagram (64-Pin TQFP and QFN<sup>(1)</sup>)



# PIC24FJ256GA110 FAMILY

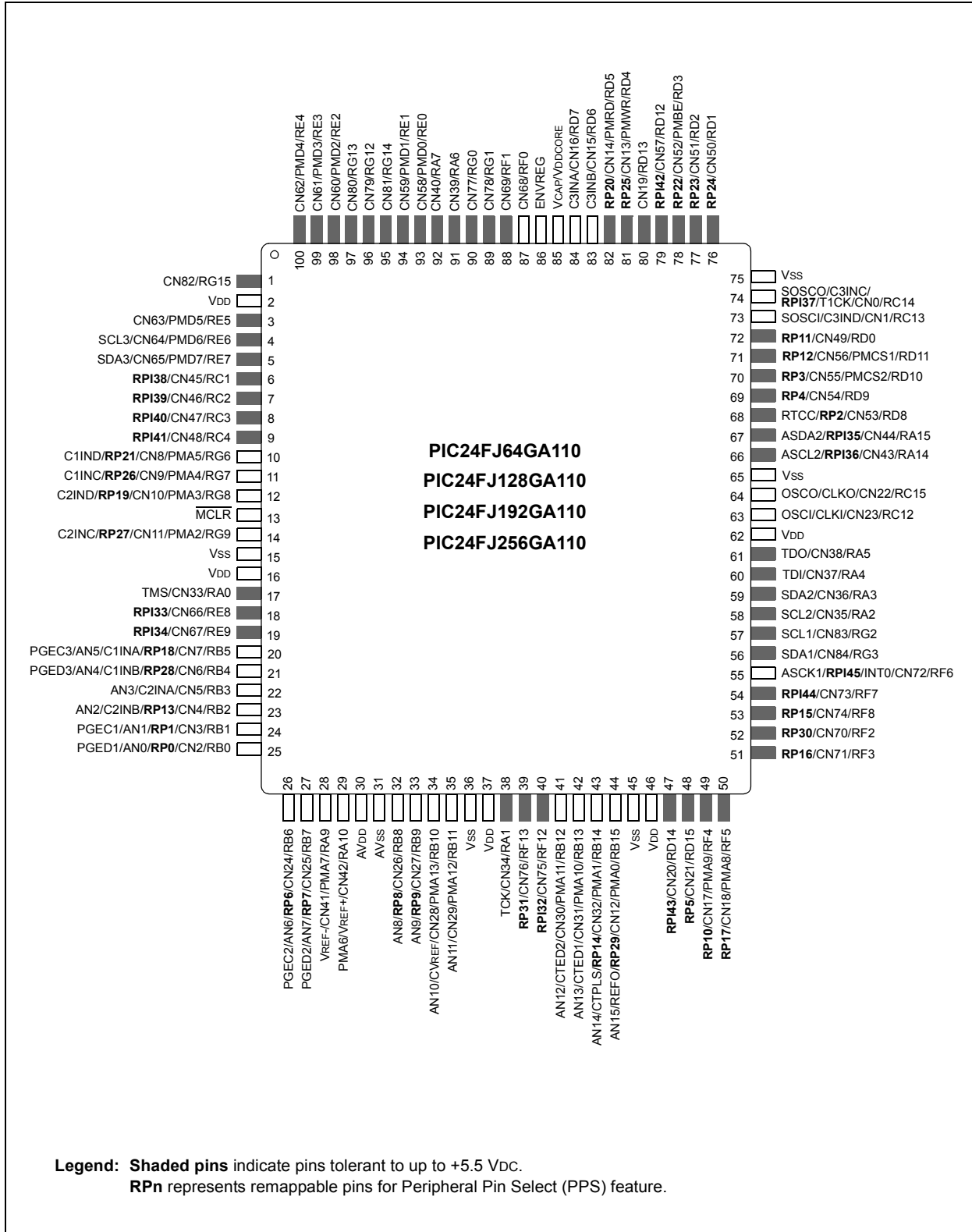
## Pin Diagram (80-Pin TQFP)



**Legend:** Shaded pins indicate pins tolerant to up to +5.5 Vdc.  
 RPn represents remappable pins for Peripheral Pin Select (PPS) feature.

# PIC24FJ256GA110 FAMILY

## Pin Diagram (100-Pin TQFP)



# PIC24FJ256GA110 FAMILY

## Table of Contents

1.0	Device Overview .....	9
2.0	Guidelines for Getting Started with 16-Bit Microcontrollers .....	23
3.0	CPU .....	29
4.0	Memory Organization .....	35
5.0	Flash Program Memory .....	59
6.0	Resets .....	67
7.0	Interrupt Controller .....	73
8.0	Oscillator Configuration .....	117
9.0	Power-Saving Features .....	127
10.0	I/O Ports .....	129
11.0	Timer1 .....	157
12.0	Timer2/3 and Timer4/5 .....	159
13.0	Input Capture with Dedicated Timer .....	165
14.0	Output Compare with Dedicated Timer .....	169
15.0	Serial Peripheral Interface (SPI) .....	177
16.0	Inter-Integrated Circuit (I <sup>2</sup> C) .....	187
17.0	Universal Asynchronous Receiver Transmitter (UART) .....	195
18.0	Parallel Master Port (PMP) .....	203
19.0	Real-Time Clock and Calendar (RTCC) .....	213
20.0	Programmable Cyclic Redundancy Check (CRC) Generator .....	223
21.0	10-Bit High-Speed A/D Converter .....	227
22.0	Triple Comparator Module .....	237
23.0	Comparator Voltage Reference .....	241
24.0	Charge Time Measurement Unit (CTMU) .....	243
25.0	Special Features .....	247
26.0	Instruction Set Summary .....	259
27.0	Development Support .....	267
28.0	Electrical Characteristics .....	269
29.0	Packaging Information .....	305
Appendix A: Revision History .....		319
Index .....		321
The Microchip Website .....		327
Customer Change Notification Service .....		327
Customer Support .....		327
Product Identification System .....		329

# PIC24FJ256GA110 FAMILY

---

---

## TO OUR VALUED CUSTOMERS

It is our intention to provide our valued customers with the best documentation possible to ensure successful use of your Microchip products. To this end, we will continue to improve our publications to better suit your needs. Our publications will be refined and enhanced as new volumes and updates are introduced.

If you have any questions or comments regarding this publication, please contact the Marketing Communications Department via E-mail at [docerrors@microchip.com](mailto:docerrors@microchip.com). We welcome your feedback.

### Most Current Data Sheet

To obtain the most up-to-date version of this data sheet, please register at our Worldwide Website at:

<http://www.microchip.com>

You can determine the version of a data sheet by examining its literature number found on the bottom outside corner of any page. The last character of the literature number is the version number, (e.g., DS30000000A is version A of document DS30000000).

### Errata

An errata sheet, describing minor operational differences from the data sheet and recommended work arounds, may exist for current devices. As device/documentation issues become known to us, we will publish an errata sheet. The errata will specify the revision of silicon and revision of document to which it applies.

To determine if an errata sheet exists for a particular device, please check with one of the following:

- Microchip's Worldwide Website; <http://www.microchip.com>
- Your local Microchip sales office (see last page)

When contacting a sales office, please specify which device, revision of silicon and data sheet (include literature number) you are using.

### Customer Notification System

Register on our website at [www.microchip.com](http://www.microchip.com) to receive the most current information on all of our products.

# PIC24FJ256GA110 FAMILY

---

## Referenced Sources

This device data sheet is based on the following individual chapters of the “*dsPIC33/PIC24 Family Reference Manual*”. These documents should be considered as the general reference for the operation of a particular module or device feature.

**Note 1:** To access the documents listed below, browse to the documentation section of the [PIC24FJ256GA110 family](http://www.microchip.com) product page of the Microchip website ([www.microchip.com](http://www.microchip.com)) or select a family reference manual section from the following list.

In addition to parameters, features and other documentation, the resulting page provides links to the related family reference manual sections.

- “CPU” ([www.microchip.com/DS39703](http://www.microchip.com/DS39703))
- “PIC24F Flash Program Memory” ([www.microchip.com/DS30009715](http://www.microchip.com/DS30009715))
- “PIC24F Data Memory” ([www.microchip.com/DS30009717](http://www.microchip.com/DS30009717))
- “Reset” ([www.microchip.com/DS39712](http://www.microchip.com/DS39712))
- “Interrupts” ([www.microchip.com/DS70000600](http://www.microchip.com/DS70000600))
- “Oscillator” ([www.microchip.com/DS39700](http://www.microchip.com/DS39700))
- “Power-Saving Features” ([www.microchip.com/DS39698](http://www.microchip.com/DS39698))
- “I/O Ports with Peripheral Pin Select (PPS)” ([www.microchip.com/DS00039711](http://www.microchip.com/DS00039711))
- “Timers” ([www.microchip.com/DS39704](http://www.microchip.com/DS39704))
- “Input Capture with Dedicated Timer” ([www.microchip.com/DS70000352](http://www.microchip.com/DS70000352))
- “Output Compare with Dedicated Timer” ([www.microchip.com/DS70005159](http://www.microchip.com/DS70005159))
- “Serial Peripheral Interface (SPI)” ([www.microchip.com/DS70005185](http://www.microchip.com/DS70005185))
- “Inter-Integrated Circuit (I<sup>2</sup>C)” ([www.microchip.com/DS70000195](http://www.microchip.com/DS70000195))
- “Universal Asynchronous Receiver Transmitter (UART)” ([www.microchip.com/DS70000582](http://www.microchip.com/DS70000582))
- “Parallel Master Port (PMP)” ([www.microchip.com/DS70005344](http://www.microchip.com/DS70005344))
- “Real-Time Clock and Calendar (RTCC)” ([www.microchip.com/DS39696](http://www.microchip.com/DS39696))
- “Programmable Cyclic Redundancy Check (CRC)” ([www.microchip.com/DS39714](http://www.microchip.com/DS39714))
- “10-Bit A/D Converter” ([www.microchip.com/DS39705](http://www.microchip.com/DS39705))
- “Scalable Comparator Module” ([www.microchip.com/DS39734](http://www.microchip.com/DS39734))
- “Charge Time Measurement Unit (CTMU)” ([www.microchip.com/DS39724](http://www.microchip.com/DS39724))
- “High-Level Device Integration” ([www.microchip.com/DS39719](http://www.microchip.com/DS39719))
- “Watchdog Timer (WDT)” ([www.microchip.com/DS39697](http://www.microchip.com/DS39697))
- “CodeGuard™ Intermediate Security” ([www.microchip.com/DS70005182](http://www.microchip.com/DS70005182))
- “Programming and Diagnostics” ([www.microchip.com/DS39716](http://www.microchip.com/DS39716))
- “Comparator Voltage Reference Module” ([www.microchip.com/DS39709](http://www.microchip.com/DS39709))

# PIC24FJ256GA110 FAMILY

---

NOTES:

# PIC24FJ256GA110 FAMILY

## 1.0 DEVICE OVERVIEW

This document contains device-specific information for the following devices:

- PIC24FJ64GA106
- PIC24FJ128GA106
- PIC24FJ192GA106
- PIC24FJ256GA106
- PIC24FJ64GA108
- PIC24FJ128GA108
- PIC24FJ192GA108
- PIC24FJ256GA108
- PIC24FJ64GA110
- PIC24FJ128GA110
- PIC24FJ192GA110
- PIC24FJ256GA110

This family expands on the existing line of Microchip's 16-bit general purpose microcontrollers, combining enhanced computational performance with an expanded and highly configurable peripheral feature set. The PIC24FJ256GA110 family provides a new platform for high-performance applications, which have outgrown their 8-bit platforms, but don't require the power of a digital signal processor.

### 1.1 Core Features

#### 1.1.1 16-BIT ARCHITECTURE

Central to all PIC24F devices is the 16-bit modified Harvard architecture, first introduced with Microchip's dsPIC® digital signal controllers. The PIC24F CPU core offers a wide range of enhancements, such as:

- 16-bit data and 24-bit address paths with the ability to move information between data and memory spaces
- Linear addressing of up to 12 Mbytes (program space) and 64 Kbytes (data)
- A 16-element Working Register array with built-in software stack support
- A 17 x 17 hardware multiplier with support for integer math
- Hardware support for 32 by 16-bit division
- An instruction set that supports multiple addressing modes and is optimized for high-level languages, such as 'C'
- Operational performance up to 16 MIPS

#### 1.1.2 POWER-SAVING TECHNOLOGY

All of the devices in the PIC24FJ256GA110 family incorporate a range of features that can significantly reduce power consumption during operation. Key items include:

- **On-the-Fly Clock Switching:** The device clock can be changed under software control to the Timer1 source or the internal, low-power RC Oscillator during operation, allowing the user to incorporate power-saving ideas into their software designs.

- **Doze Mode Operation:** When timing-sensitive applications, such as serial communications, require the uninterrupted operation of peripherals, the CPU clock speed can be selectively reduced, allowing incremental power savings without missing a beat.
- **Instruction-Based Power-Saving Modes:** The microcontroller can suspend all operations, or selectively shut down its core while leaving its peripherals active, with a single instruction in software.

#### 1.1.3 OSCILLATOR OPTIONS AND FEATURES

All of the devices in the PIC24FJ256GA110 family offer five different oscillator options, allowing users a range of choices in developing application hardware. These include:

- Two Crystal modes using crystals or ceramic resonators.
- Two External Clock modes offering the option of a divide-by-2 clock output.
- A Fast Internal Oscillator (FRC) with a nominal 8 MHz output, which can also be divided under software control to provide clock speeds as low as 31 kHz.
- A Phase-Locked Loop (PLL) frequency multiplier available to the external oscillator modes and the FRC Oscillator, which allows clock speeds of up to 32 MHz.
- A separate internal RC Oscillator (LPRC) with a fixed 31 kHz output, which provides a low-power option for timing-insensitive applications.

The internal oscillator block also provides a stable reference source for the Fail-Safe Clock Monitor. This option constantly monitors the main clock source against a reference signal provided by the internal oscillator and enables the controller to switch to the internal oscillator, allowing for continued low-speed operation or a safe application shutdown.

#### 1.1.4 EASY MIGRATION

Regardless of the memory size, all devices share the same rich set of peripherals, allowing for a smooth migration path as applications grow and evolve. The consistent pinout scheme used throughout the entire family also aids in migrating from one device to the next larger, or even in jumping from 64-pin to 100-pin devices.

The PIC24F family is pin-compatible with devices in the dsPIC33 and PIC32 families, and shares some compatibility with the pinout schema for PIC18 and dsPIC30 devices. This extends the ability of applications to grow from the relatively simple, to the powerful and complex, yet still selecting a Microchip device.

# PIC24FJ256GA110 FAMILY

---

## 1.2 Other Special Features

- **Peripheral Pin Select:** The Peripheral Pin Select (PPS) feature allows most digital peripherals to be mapped over a fixed set of digital I/O pins. Users may independently map the input and/or output of any one of the many digital peripherals to any one of the I/O pins.
- **Communications:** The PIC24FJ256GA110 family incorporates a range of serial communication peripherals to handle a range of application requirements. There are three independent I<sup>2</sup>C modules that support both Master and Slave modes of operation. Devices also have, through the Peripheral Pin Select (PPS) feature, four independent UARTs with built-in IrDA<sup>®</sup> encoder/decoders and three SPI modules.
- **Analog Features:** All members of the PIC24FJ256GA110 family include a 10-bit A/D Converter module and a triple comparator module. The A/D module incorporates program-mable acquisition time, allowing for a channel to be selected and a conversion to be initiated without waiting for a sampling period, as well as faster sampling speeds. The comparator module includes three analog comparators that are configurable for a wide range of operations.
- **CTMU Interface:** In addition to their other analog features, members of the PIC24FJ256GA110 family include the brand new CTMU interface module. This provides a convenient method for precision time measurement and pulse generation, and can serve as an interface for capacitive sensors.
- **Parallel Master Port:** One of the general purpose I/O ports can be reconfigured for enhanced parallel data communications. In this mode, the port can be configured for both master and slave operations, and supports 8-bit transfers with up to 16 external address lines in Master modes.
- **Real-Time Clock/Calendar:** This module implements a full-featured clock and calendar with alarm functions in hardware, freeing up the timer resources and program memory space for the use of the core application.

## 1.3 Details on Individual Family Members

Devices in the PIC24FJ256GA110 family are available in 64-pin, 80-pin and 100-pin packages. The general block diagram for all devices is shown in [Figure 1-1](#).

The devices are differentiated from each other in four ways:

1. Flash program memory (64 Kbytes for PIC24FJ64GA1 devices, 128 Kbytes for PIC24FJ128GA1 devices, 192 Kbytes for PIC24FJ192GA1 devices and 256 Kbytes for PIC24FJ256GA1 devices).
2. Available I/O pins and ports (53 pins on six ports for 64-pin devices, 69 pins on seven ports for 80-pin devices and 85 pins on seven ports for 100-pin devices).
3. Available Interrupt-on-Change Notification (ICN) inputs (same as the number of available I/O pins for all devices).
4. Available remappable pins (31 pins on 64-pin devices, 42 pins on 80-pin devices and 46 pins on 100-pin devices)

All other features for devices in this family are identical. These are summarized in [Table 1-1](#).

A list of the pin features available on the PIC24FJ256GA110 family devices, sorted by function, is shown in [Table 1-4](#). Note that this table shows the pin location of individual peripheral features and not how they are multiplexed on the same pin. This information is provided in the pinout diagrams in the beginning of this data sheet. Multiplexed features are sorted by the priority given to a feature, with the highest priority peripheral being listed first.

# PIC24FJ256GA110 FAMILY

**TABLE 1-1: DEVICE FEATURES FOR THE PIC24FJ256GA110 FAMILY: 64-PIN DEVICES**

Features	PIC24FJ64GA106	PIC24FJ128GA106	PIC24FJ192GA106	PIC24FJ256GA106
Operating Frequency	DC – 32 MHz			
Program Memory (bytes)	64K	128K	192K	256K
Program Memory (instructions)	22,016	44,032	67,072	87,552
Data Memory (bytes)	16,384			
Interrupt Sources (soft vectors/NMI traps)	66 (62/4)			
I/O Ports	Ports B, C, D, E, F, G			
Total I/O Pins	53			
Remappable Pins	31 (29 I/O, 2 input only)			
Timers:				
Total Number (16-bit)	5 <sup>(1)</sup>			
32-Bit (from paired 16-bit timers)	2			
Input Capture Channels	9 <sup>(1)</sup>			
Output Compare/PWM Channels	9 <sup>(1)</sup>			
Input Change Notification Interrupt	53			
Serial Communications:				
UART	4 <sup>(1)</sup>			
SPI (three-wire/four-wire)	3 <sup>(1)</sup>			
I <sup>2</sup> C	3			
Parallel Communications (PMP/PSP)	Yes			
JTAG Boundary Scan	Yes			
10-Bit Analog-to-Digital Module (input channels)	16			
Analog Comparators	3			
CTMU Interface	Yes			
Resets (and delays)	POR, BOR, RESET Instruction, MCLR, WDT; Illegal Opcode, REPEAT Instruction, Hardware Traps, Configuration Word Mismatch (PWRT, OST, PLL Lock)			
Instruction Set	76 Base Instructions, Multiple Addressing Mode Variations			
Packages	64-Pin TQFP			

**Note 1:** Peripherals are accessible through remappable pins.

# PIC24FJ256GA110 FAMILY

**TABLE 1-2: DEVICE FEATURES FOR THE PIC24FJ256GA110 FAMILY: 80-PIN DEVICES**

Features	PIC24FJ64GA108	PIC24FJ128GA108	PIC24FJ192GA108	PIC24FJ256GA108
Operating Frequency	DC – 32 MHz			
Program Memory (bytes)	64K	128K	192K	256K
Program Memory (instructions)	22,016	44,032	67,072	87,552
Data Memory (bytes)	16,384			
Interrupt Sources (soft vectors/NMI traps)	66 (62/4)			
I/O Ports	Ports A, B, C, D, E, F, G			
Total I/O Pins	69			
Remappable Pins	42 (31 I/O, 11 input only)			
Timers:				
Total Number (16-bit)	5 <sup>(1)</sup>			
32-Bit (from paired 16-bit timers)	2			
Input Capture Channels	9 <sup>(1)</sup>			
Output Compare/PWM Channels	9 <sup>(1)</sup>			
Input Change Notification Interrupt	69			
Serial Communications:				
UART	4 <sup>(1)</sup>			
SPI (three-wire/four-wire)	3 <sup>(1)</sup>			
I <sup>2</sup> C	3			
Parallel Communications (PMP/PSP)	Yes			
JTAG Boundary Scan	Yes			
10-Bit Analog-to-Digital Module (input channels)	16			
Analog Comparators	3			
CTMU Interface	Yes			
Resets (and delays)	POR, BOR, RESET Instruction, MCLR, WDT; Illegal Opcode, REPEAT Instruction, Hardware Traps, Configuration Word Mismatch (PWRT, OST, PLL Lock)			
Instruction Set	76 Base Instructions, Multiple Addressing Mode Variations			
Packages	80-Pin TQFP			

**Note 1:** Peripherals are accessible through remappable pins.

# PIC24FJ256GA110 FAMILY

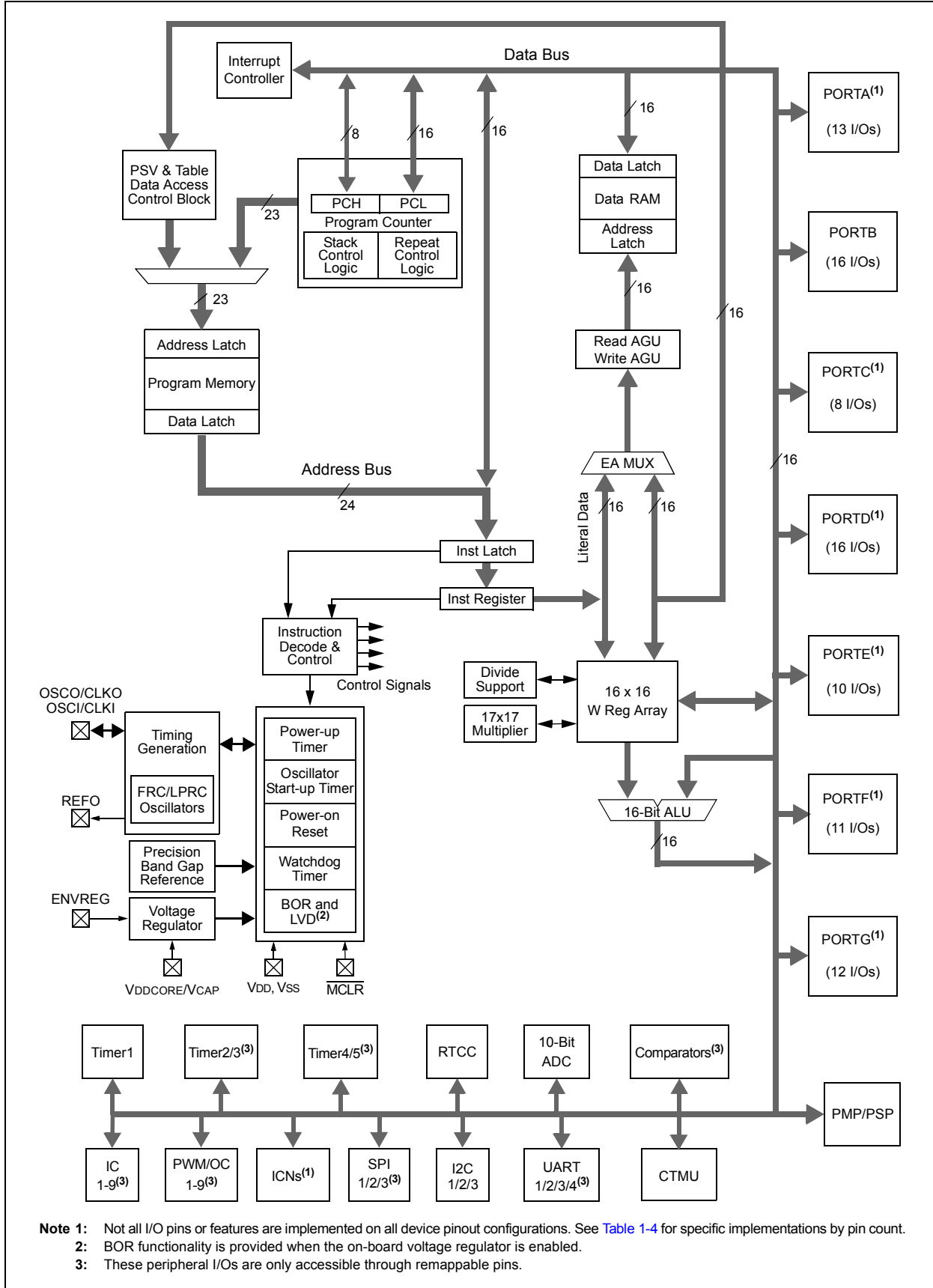
**TABLE 1-3: DEVICE FEATURES FOR THE PIC24FJ256GA110 FAMILY: 100-PIN DEVICES**

Features	PIC24FJ64GA110	PIC24FJ128GA110	PIC24FJ192GA110	PIC24FJ256GA110
Operating Frequency	DC – 32 MHz			
Program Memory (bytes)	64K	128K	192K	256K
Program Memory (instructions)	22,016	44,032	67,072	87,552
Data Memory (bytes)	16,384			
Interrupt Sources (soft vectors/NMI traps)	66 (62/4)			
I/O Ports	Ports A, B, C, D, E, F, G			
Total I/O Pins	85			
Remappable Pins	46 (32 I/O, 14 input only)			
Timers:				
Total Number (16-bit)	5 <sup>(1)</sup>			
32-Bit (from paired 16-bit timers)	2			
Input Capture Channels	9 <sup>(1)</sup>			
Output Compare/PWM Channels	9 <sup>(1)</sup>			
Input Change Notification Interrupt	85			
Serial Communications:				
UART	4 <sup>(1)</sup>			
SPI (three-wire/four-wire)	3 <sup>(1)</sup>			
I <sup>2</sup> C	3			
Parallel Communications (PMP/PSP)	Yes			
JTAG Boundary Scan	Yes			
10-Bit Analog-to-Digital Module (input channels)	16			
Analog Comparators	3			
CTMU Interface	Yes			
Resets (and delays)	POR, BOR, RESET Instruction, MCLR, WDT; Illegal Opcode, REPEAT Instruction, Hardware Traps, Configuration Word Mismatch (PWRT, OST, PLL Lock)			
Instruction Set	76 Base Instructions, Multiple Addressing Mode Variations			
Packages	100-Pin TQFP			

**Note 1:** Peripherals are accessible through remappable pins.

# PIC24FJ256GA110 FAMILY

FIGURE 1-1: PIC24FJ256GA110 FAMILY GENERAL BLOCK DIAGRAM



# PIC24FJ256GA110 FAMILY

**TABLE 1-4: PIC24FJ256GA110 FAMILY PINOUT DESCRIPTIONS**

Function	Pin Number			I/O	Input Buffer	Description
	64-Pin TQFP, QFN	80-Pin TQFP	100-Pin TQFP			
AN0	16	20	25	I	ANA	A/D Analog Inputs.
AN1	15	19	24	I	ANA	
AN2	14	18	23	I	ANA	
AN3	13	17	22	I	ANA	
AN4	12	16	21	I	ANA	
AN5	11	15	20	I	ANA	
AN6	17	21	26	I	ANA	
AN7	18	22	27	I	ANA	
AN8	21	27	32	I	ANA	
AN9	22	28	33	I	ANA	
AN10	23	29	34	I	ANA	
AN11	24	30	35	I	ANA	
AN12	27	33	41	I	ANA	
AN13	28	34	42	I	ANA	
AN14	29	35	43	I	ANA	
AN15	30	36	44	I	ANA	
ASCL2	—	—	66	I/O	I <sup>2</sup> C	Alternate I2C2 Synchronous Serial Clock Input/Output.
ASDA2	—	—	67	I/O	I <sup>2</sup> C	Alternate I2C2 Data Input/Output.
AVDD	19	25	30	P	—	Positive Supply for Analog modules.
AVSS	20	26	31	P	—	Ground Reference for Analog modules.
C1INA	11	15	20	I	ANA	Comparator 1 Input A.
C1INB	12	16	21	I	ANA	Comparator 1 Input B.
C1INC	5	7	11	I	ANA	Comparator 1 Input C.
C1IND	4	6	10	I	ANA	Comparator 1 Input D.
C2INA	13	17	22	I	ANA	Comparator 2 Input A.
C2INB	14	18	23	I	ANA	Comparator 2 Input B.
C2INC	8	10	14	I	ANA	Comparator 2 Input C.
C2IND	6	8	12	I	ANA	Comparator 2 Input D.
C3INA	55	69	84	I	ANA	Comparator 3 Input A.
C3INB	54	68	83	I	ANA	Comparator 3 Input B.
C3INC	48	60	74	I	ANA	Comparator 3 Input C.
C3IND	47	59	73	I	ANA	Comparator 3 Input D.
CLKI	39	49	63	I	ANA	Main Clock Input Connection.
CLKO	40	50	64	O	—	System Clock Output.

**Legend:** TTL = TTL input buffer  
ANA = Analog level input/output

ST = Schmitt Trigger input buffer  
I<sup>2</sup>C = I<sup>2</sup>C/SMBus input buffer

# PIC24FJ256GA110 FAMILY

**TABLE 1-4: PIC24FJ256GA110 FAMILY PINOUT DESCRIPTIONS (CONTINUED)**

Function	Pin Number			I/O	Input Buffer	Description
	64-Pin TQFP, QFN	80-Pin TQFP	100-Pin TQFP			
CN0	48	60	74	I	ST	Interrupt-on-Change Inputs.
CN1	47	59	73	I	ST	
CN2	16	20	25	I	ST	
CN3	15	19	24	I	ST	
CN4	14	18	23	I	ST	
CN5	13	17	22	I	ST	
CN6	12	16	21	I	ST	
CN7	11	15	20	I	ST	
CN8	4	6	10	I	ST	
CN9	5	7	11	I	ST	
CN10	6	8	12	I	ST	
CN11	8	10	14	I	ST	
CN12	30	36	44	I	ST	
CN13	52	66	81	I	ST	
CN14	53	67	82	I	ST	
CN15	54	68	83	I	ST	
CN16	55	69	84	I	ST	
CN17	31	39	49	I	ST	
CN18	32	40	50	I	ST	
CN19	—	65	80	I	ST	
CN20	—	37	47	I	ST	
CN21	—	38	48	I	ST	
CN22	40	50	64	I	ST	
CN23	39	49	63	I	ST	
CN24	17	21	26	I	ST	
CN25	18	22	27	I	ST	
CN26	21	27	32	I	ST	
CN27	22	28	33	I	ST	
CN28	23	29	34	I	ST	
CN29	24	30	35	I	ST	
CN30	27	33	41	I	ST	
CN31	28	34	42	I	ST	
CN32	29	35	43	I	ST	
CN33	—	—	17	I	ST	
CN34	—	—	38	I	ST	
CN35	—	—	58	I	ST	
CN36	—	—	59	I	ST	
CN37	—	—	60	I	ST	
CN38	—	—	61	I	ST	
CN39	—	—	91	I	ST	
CN40	—	—	92	I	ST	
CN41	—	23	28	I	ST	
CN42	—	24	29	I	ST	

**Legend:** TTL = TTL input buffer  
ANA = Analog level input/output

ST = Schmitt Trigger input buffer  
I<sup>2</sup>C = I<sup>2</sup>C/SMBus input buffer

# PIC24FJ256GA110 FAMILY

**TABLE 1-4: PIC24FJ256GA110 FAMILY PINOUT DESCRIPTIONS (CONTINUED)**

Function	Pin Number			I/O	Input Buffer	Description
	64-Pin TQFP, QFN	80-Pin TQFP	100-Pin TQFP			
CN43	—	52	66	I	ST	Interrupt-on-Change Inputs.
CN44	—	53	67	I	ST	
CN45	—	4	6	I	ST	
CN46	—	—	7	I	ST	
CN47	—	5	8	I	ST	
CN48	—	—	9	I	ST	
CN49	46	58	72	I	ST	
CN50	49	61	76	I	ST	
CN51	50	62	77	I	ST	
CN52	51	63	78	I	ST	
CN53	42	54	68	I	ST	
CN54	43	55	69	I	ST	
CN55	44	56	70	I	ST	
CN56	45	57	71	I	ST	
CN57	—	64	79	I	ST	
CN58	60	76	93	I	ST	
CN59	61	77	94	I	ST	
CN60	62	78	98	I	ST	
CN61	63	79	99	I	ST	
CN62	64	80	100	I	ST	
CN63	1	1	3	I	ST	
CN64	2	2	4	I	ST	
CN65	3	3	5	I	ST	
CN66	—	13	18	I	ST	
CN67	—	14	19	I	ST	
CN68	58	72	87	I	ST	
CN69	59	73	88	I	ST	
CN70	34	42	52	I	ST	
CN71	33	41	51	I	ST	
CN72	35	45	55	I	ST	
CN73	—	44	54	I	ST	
CN74	—	43	53	I	ST	
CN75	—	—	40	I	ST	
CN76	—	—	39	I	ST	
CN77	—	75	90	I	ST	
CN78	—	74	89	I	ST	
CN79	—	—	96	I	ST	
CN80	—	—	97	I	ST	
CN81	—	—	95	I	ST	
CN82	—	—	1	I	ST	
CN83	37	47	57	I	ST	
CN84	36	46	56	I	ST	

**Legend:** TTL = TTL input buffer  
ANA = Analog level input/output

ST = Schmitt Trigger input buffer  
I<sup>2</sup>C = I<sup>2</sup>C/SMBus input buffer

# PIC24FJ256GA110 FAMILY

**TABLE 1-4: PIC24FJ256GA110 FAMILY PINOUT DESCRIPTIONS (CONTINUED)**

Function	Pin Number			I/O	Input Buffer	Description
	64-Pin TQFP, QFN	80-Pin TQFP	100-Pin TQFP			
CTED1	28	34	42	I	ANA	CTMU External Edge Input 1.
CTED2	27	33	41	I	ANA	CTMU External Edge Input 2.
CTPLS	29	35	43	O	—	CTMU Pulse Output.
CVREF	23	29	34	O	—	Comparator Voltage Reference Output.
ENVREG	57	71	86	I	ST	Voltage Regulator Enable.
INT0	35	45	55	I	ST	External Interrupt Input.
$\overline{\text{MCLR}}$	7	9	13	I	ST	Master Clear (device Reset) Input. This line is brought low to cause a Reset.
OSCI	39	49	63	I	ANA	Main Oscillator Input Connection.
OSCO	40	50	64	O	ANA	Main Oscillator Output Connection.
PGEC1	15	19	24	I/O	ST	In-Circuit Debugger/Emulator/ICSP™ Programming Clock.
PGED1	16	20	25	I/O	ST	In-Circuit Debugger/Emulator/ICSP Programming Data.
PGEC2	17	21	26	I/O	ST	In-Circuit Debugger/Emulator/ICSP Programming Clock.
PGED2	18	22	27	I/O	ST	In-Circuit Debugger/Emulator/ICSP Programming Data.
PGEC3	11	15	20	I/O	ST	In-Circuit Debugger/Emulator/ICSP Programming Clock.
PGED3	12	16	21	I/O	ST	In-Circuit Debugger/Emulator/ICSP Programming Data.
PMA0	30	36	44	I/O	ST	Parallel Master Port Address Bit 0 Input (Buffered Slave modes) and Output (Master modes).
PMA1	29	35	43	I/O	ST	Parallel Master Port Address Bit 1 Input (Buffered Slave modes) and Output (Master modes).
PMA2	8	10	14	O	—	Parallel Master Port Address (Demultiplexed Master modes).
PMA3	6	8	12	O	—	
PMA4	5	7	11	O	—	
PMA5	4	6	10	O	—	
PMA6	16	24	29	O	—	
PMA7	22	23	28	O	—	
PMA8	32	40	50	O	—	
PMA9	31	39	49	O	—	
PMA10	28	34	42	O	—	
PMA11	27	33	41	O	—	
PMA12	24	30	35	O	—	
PMA13	23	29	34	O	—	
PMCS1	45	57	71	I/O	ST/TTL	Parallel Master Port Chip Select 1 Strobe/Address Bit 15.
PMCS2	44	56	70	O	ST	Parallel Master Port Chip Select 2 Strobe/Address Bit 14.
PMBE	51	63	78	O	—	Parallel Master Port Byte Enable Strobe.
PMD0	60	76	93	I/O	ST/TTL	Parallel Master Port Data (Demultiplexed Master mode) or Address/Data (Multiplexed Master modes).
PMD1	61	77	94	I/O	ST/TTL	
PMD2	62	78	98	I/O	ST/TTL	
PMD3	63	79	99	I/O	ST/TTL	
PMD4	64	80	100	I/O	ST/TTL	
PMD5	1	1	3	I/O	ST/TTL	
PMD6	2	2	4	I/O	ST/TTL	
PMD7	3	3	5	I/O	ST/TTL	
PMRD	53	67	82	O	—	Parallel Master Port Read Strobe.
PMWR	52	66	81	O	—	Parallel Master Port Write Strobe.

**Legend:** TTL = TTL input buffer  
ANA = Analog level input/output

ST = Schmitt Trigger input buffer  
I<sup>2</sup>C = I<sup>2</sup>C/SMBus input buffer

# PIC24FJ256GA110 FAMILY

**TABLE 1-4: PIC24FJ256GA110 FAMILY PINOUT DESCRIPTIONS (CONTINUED)**

Function	Pin Number			I/O	Input Buffer	Description	
	64-Pin TQFP, QFN	80-Pin TQFP	100-Pin TQFP				
RA0	—	—	17	I/O	ST	PORTA Digital I/Os.	
RA1	—	—	38	I/O	ST		
RA2	—	—	58	I/O	ST		
RA3	—	—	59	I/O	ST		
RA4	—	—	60	I/O	ST		
RA5	—	—	61	I/O	ST		
RA6	—	—	91	I/O	ST		
RA7	—	—	92	I/O	ST		
RA9	—	23	28	I/O	ST		
RA10	—	24	29	I/O	ST		
RA14	—	52	66	I/O	ST		
RA15	—	53	67	I/O	ST		
RB0	16	20	25	I/O	ST		PORTB Digital I/Os.
RB1	15	19	24	I/O	ST		
RB2	14	18	23	I/O	ST		
RB3	13	17	22	I/O	ST		
RB4	12	16	21	I/O	ST		
RB5	11	15	20	I/O	ST		
RB6	17	21	26	I/O	ST		
RB7	18	22	27	I/O	ST		
RB8	21	27	32	I/O	ST		
RB9	22	28	33	I/O	ST		
RB10	23	29	34	I/O	ST		
RB11	24	30	35	I/O	ST		
RB12	27	33	41	I/O	ST		
RB13	28	34	42	I/O	ST		
RB14	29	35	43	I/O	ST		
RB15	30	36	44	I/O	ST		
RC1	—	4	6	I/O	ST	PORTC Digital I/Os.	
RC2	—	—	7	I/O	ST		
RC3	—	5	8	I/O	ST		
RC4	—	—	9	I/O	ST		
RC12	39	49	63	I/O	ST		
RC13	47	59	73	I/O	ST		
RC14	48	60	74	I/O	ST		
RC15	40	50	64	I/O	ST		

**Legend:** TTL = TTL input buffer  
ANA = Analog level input/output

ST = Schmitt Trigger input buffer  
I<sup>2</sup>C = I<sup>2</sup>C/SMBus input buffer

# PIC24FJ256GA110 FAMILY

**TABLE 1-4: PIC24FJ256GA110 FAMILY PINOUT DESCRIPTIONS (CONTINUED)**

Function	Pin Number			I/O	Input Buffer	Description
	64-Pin TQFP, QFN	80-Pin TQFP	100-Pin TQFP			
RD0	46	58	72	I/O	ST	PORTD Digital I/Os.
RD1	49	61	76	I/O	ST	
RD2	50	62	77	I/O	ST	
RD3	51	63	78	I/O	ST	
RD4	52	66	81	I/O	ST	
RD5	53	67	82	I/O	ST	
RD6	54	68	83	I/O	ST	
RD7	55	69	84	I/O	ST	
RD8	42	54	68	I/O	ST	
RD9	43	55	69	I/O	ST	
RD10	44	56	70	I/O	ST	
RD11	45	57	71	I/O	ST	
RD12	—	64	79	I/O	ST	
RD13	—	65	80	I/O	ST	
RD14	—	37	47	I/O	ST	
RD15	—	38	48	I/O	ST	
RE0	60	76	93	I/O	ST	PORTE Digital I/Os.
RE1	61	77	94	I/O	ST	
RE2	62	78	98	I/O	ST	
RE3	63	79	99	I/O	ST	
RE4	64	80	100	I/O	ST	
RE5	1	1	3	I/O	ST	
RE6	2	2	4	I/O	ST	
RE7	3	3	5	I/O	ST	
RE8	—	13	18	I/O	ST	
RE9	—	14	19	I/O	ST	
REFO	30	36	44	O	—	Reference Clock Output.
RF0	58	72	87	I/O	ST	PORTF Digital I/Os.
RF1	59	73	88	I/O	ST	
RF2	34	42	52	I/O	ST	
RF3	33	41	51	I/O	ST	
RF4	31	39	49	I/O	ST	
RF5	32	40	50	I/O	ST	
RF6	35	45	55	I/O	ST	
RF7	—	44	54	I/O	ST	
RF8	—	43	53	I/O	ST	
RF12	—	—	40	I/O	ST	
RF13	—	—	39	I/O	ST	

**Legend:** TTL = TTL input buffer  
ANA = Analog level input/output

ST = Schmitt Trigger input buffer  
I<sup>2</sup>C = I<sup>2</sup>C/SMBus input buffer

# PIC24FJ256GA110 FAMILY

**TABLE 1-4: PIC24FJ256GA110 FAMILY PINOUT DESCRIPTIONS (CONTINUED)**

Function	Pin Number			I/O	Input Buffer	Description	
	64-Pin TQFP, QFN	80-Pin TQFP	100-Pin TQFP				
RG0	—	75	90	I/O	ST	PORTG Digital I/Os.	
RG1	—	74	89	I/O	ST		
RG2	37	47	57	I/O	ST		
RG3	36	46	56	I/O	ST		
RG6	4	6	10	I/O	ST		
RG7	5	7	11	I/O	ST		
RG8	6	8	12	I/O	ST		
RG9	8	10	14	I/O	ST		
RG12	—	—	96	I/O	ST		
RG13	—	—	97	I/O	ST		
RG14	—	—	95	I/O	ST		
RG15	—	—	1	I/O	ST		
RP0	16	20	25	I/O	ST		Remappable Peripheral (input or output).
RP1	15	19	24	I/O	ST		
RP2	42	54	68	I/O	ST		
RP3	44	56	70	I/O	ST		
RP4	43	55	69	I/O	ST		
RP5	—	38	48	I/O	ST		
RP6	17	21	26	I/O	ST		
RP7	18	22	27	I/O	ST		
RP8	21	27	32	I/O	ST		
RP9	22	28	33	I/O	ST		
RP10	31	39	49	I/O	ST		
RP11	46	58	72	I/O	ST		
RP12	45	57	71	I/O	ST		
RP13	14	18	23	I/O	ST		
RP14	29	35	43	I/O	ST		
RP15	—	43	53	I/O	ST		
RP16	33	41	51	I/O	ST		
RP17	32	40	50	I/O	ST		
RP18	11	15	20	I/O	ST		
RP19	6	8	12	I/O	ST		
RP20	53	67	82	I/O	ST		
RP21	4	6	10	I/O	ST		
RP22	51	63	78	I/O	ST		
RP23	50	62	77	I/O	ST		
RP24	49	61	76	I/O	ST		
RP25	52	66	81	I/O	ST		
RP26	5	7	11	I/O	ST		
RP27	8	10	14	I/O	ST		
RP28	12	16	21	I/O	ST		
RP29	30	36	44	I/O	ST		
RP30	34	42	52	I/O	ST		
RP31	—	—	39	I/O	ST		

**Legend:** TTL = TTL input buffer  
ANA = Analog level input/output

ST = Schmitt Trigger input buffer  
I<sup>2</sup>C = I<sup>2</sup>C/SMBus input buffer

# PIC24FJ256GA110 FAMILY

**TABLE 1-4: PIC24FJ256GA110 FAMILY PINOUT DESCRIPTIONS (CONTINUED)**

Function	Pin Number			I/O	Input Buffer	Description
	64-Pin TQFP, QFN	80-Pin TQFP	100-Pin TQFP			
RPI32	—	—	40	I	ST	Remappable Peripheral (input only).
RPI33	—	13	18	I	ST	
RPI34	—	14	19	I	ST	
RPI35	—	53	67	I	ST	
RPI36	—	52	66	I	ST	
RPI37	48	60	74	I	ST	
RPI38	—	4	6	I	ST	
RPI39	—	—	7	I	ST	
RPI40	—	5	8	I	ST	
RPI41	—	—	9	I	ST	
RPI42	—	64	79	I	ST	
RPI43	—	37	47	I	ST	
RPI44	—	44	54	I	ST	
RPI45	35	45	55	I	ST	
RTCC	42	54	68	O	—	
SCL1	37	47	57	I/O	I <sup>2</sup> C	I2C1 Synchronous Serial Clock Input/Output.
SCL2	32	52	58	I/O	I <sup>2</sup> C	I2C2 Synchronous Serial Clock Input/Output.
SCL3	2	2	4	I/O	I <sup>2</sup> C	I2C3 Synchronous Serial Clock Input/Output.
SDA1	36	46	56	I/O	I <sup>2</sup> C	I2C1 Data Input/Output.
SDA2	31	53	59	I/O	I <sup>2</sup> C	I2C2 Data Input/Output.
SDA3	3	3	5	I/O	I <sup>2</sup> C	I2C3 Data Input/Output.
SOSCI	47	59	73	I	ANA	Secondary Oscillator/Timer1 Clock Input.
SOSCO	48	60	74	O	ANA	Secondary Oscillator/Timer1 Clock Output.
T1CK	48	60	74	I	ST	Timer1 Clock.
TCK	27	33	38	I	ST	JTAG Test Clock Input.
TDI	28	34	60	I	ST	JTAG Test Data Input.
TDO	24	14	61	O	—	JTAG Test Data Output.
TMS	23	13	17	I	ST	JTAG Test Mode Select Input.
VCAP	56	70	85	P	—	External Filter Capacitor Connection (regulator enabled).
VDD	10, 26, 38	12, 32, 48	2, 16, 37, 46, 62	P	—	Positive Supply for Peripheral Digital Logic and I/O Pins.
VDDCORE	56	70	85	P	—	Positive Supply for Microcontroller Core Logic (regulator disabled).
VREF-	15	23	28	I	ANA	A/D and Comparator Reference Voltage (low) Input.
VREF+	16	24	29	I	ANA	A/D and Comparator Reference Voltage (high) Input.
VSS	9, 25, 41	11, 31, 51	15, 36, 45, 65, 75	P	—	Ground Reference for Logic and I/O Pins.

**Legend:** TTL = TTL input buffer  
ANA = Analog level input/output

ST = Schmitt Trigger input buffer  
I<sup>2</sup>C = I<sup>2</sup>C/SMBus input buffer

# PIC24FJ256GA110 FAMILY

## 2.0 GUIDELINES FOR GETTING STARTED WITH 16-BIT MICROCONTROLLERS

### 2.1 Basic Connection Requirements

Getting started with the PIC24FJ256GA110 family of 16-bit microcontrollers requires attention to a minimal set of device pin connections before proceeding with development.

The following pins must always be connected:

- All VDD and VSS pins (see [Section 2.2 “Power Supply Pins”](#))
- All AVDD and AVSS pins, regardless of whether or not the analog device features are used (see [Section 2.2 “Power Supply Pins”](#))
- MCLR pin (see [Section 2.3 “Master Clear \(MCLR\) Pin”](#))
- ENVREG/DISVREG and VCAP/VDDCORE pins (PIC24F J devices only) (see [Section 2.4 “Voltage Regulator Pins \(ENVREG/DISVREG and VCAP/VDDCORE\)”](#))

These pins must also be connected if they are being used in the end application:

- PGECx/PGEDx pins used for In-Circuit Serial Programming™ (ICSP™) and debugging purposes (see [Section 2.5 “ICSP Pins”](#))
- OSCI and OSCO pins when an external oscillator source is used (see [Section 2.6 “External Oscillator Pins”](#))

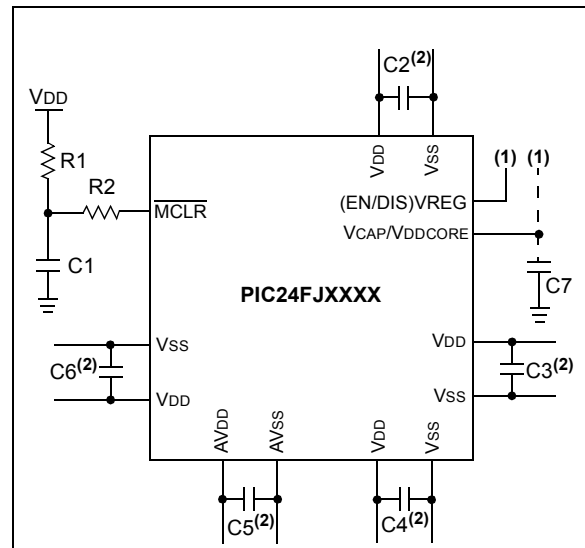
Additionally, the following pins may be required:

- VREF+/VREF- pins used when external voltage reference for analog modules is implemented

**Note:** The AVDD and AVSS pins must always be connected, regardless of whether any of the analog modules are being used.

The minimum mandatory connections are shown in [Figure 2-1](#).

FIGURE 2-1: RECOMMENDED MINIMUM CONNECTIONS



**Key (all values are recommendations):**

C1 through C6: 0.1  $\mu$ F, 20V ceramic

C7: 10  $\mu$ F, 6.3V or greater, tantalum or ceramic

R1: 10 k $\Omega$

R2: 100 $\Omega$  to 470 $\Omega$

**Note 1:** See [Section 2.4 “Voltage Regulator Pins \(ENVREG/DISVREG and VCAP/VDDCORE\)”](#) for explanation of ENVREG/DISVREG pin connections.

**2:** The example shown is for a PIC24F device with five VDD/VSS and AVDD/AVSS pairs. Other devices may have more or less pairs; adjust the number of decoupling capacitors appropriately.

# PIC24FJ256GA110 FAMILY

## 2.2 Power Supply Pins

### 2.2.1 DECOUPLING CAPACITORS

The use of decoupling capacitors on every pair of power supply pins, such as VDD, VSS, AVDD and AVSS is required.

Consider the following criteria when using decoupling capacitors:

- **Value and type of capacitor:** A 0.1  $\mu\text{F}$  (100 nF), 10-20V capacitor is recommended. The capacitor should be a low-ESR device with a resonance frequency in the range of 200 MHz and higher. Ceramic capacitors are recommended.
- **Placement on the printed circuit board:** The decoupling capacitors should be placed as close to the pins as possible. It is recommended to place the capacitors on the same side of the board as the device. If space is constricted, the capacitor can be placed on another layer on the PCB using a via; however, ensure that the trace length from the pin to the capacitor is no greater than 0.25 inch (6 mm).
- **Handling high-frequency noise:** If the board is experiencing high-frequency noise (upward of tens of MHz), add a second ceramic type capacitor in parallel to the above described decoupling capacitor. The value of the second capacitor can be in the range of 0.01  $\mu\text{F}$  to 0.001  $\mu\text{F}$ . Place this second capacitor next to each primary decoupling capacitor. In high-speed circuit designs, consider implementing a decade pair of capacitances as close to the power and ground pins as possible (e.g., 0.1  $\mu\text{F}$  in parallel with 0.001  $\mu\text{F}$ ).
- **Maximizing performance:** On the board layout from the power supply circuit, run the power and return traces to the decoupling capacitors first, and then to the device pins. This ensures that the decoupling capacitors are first in the power chain. Equally important is to keep the trace length between the capacitor and the power pins to a minimum, thereby reducing PCB trace inductance.

### 2.2.2 TANK CAPACITORS

On boards with power traces running longer than six inches in length, it is suggested to use a tank capacitor for integrated circuits including microcontrollers to supply a local power source. The value of the tank capacitor should be determined based on the trace resistance that connects the power supply source to the device, and the maximum current drawn by the device in the application. In other words, select the tank capacitor so that it meets the acceptable voltage sag at the device. Typical values range from 4.7  $\mu\text{F}$  to 47  $\mu\text{F}$ .

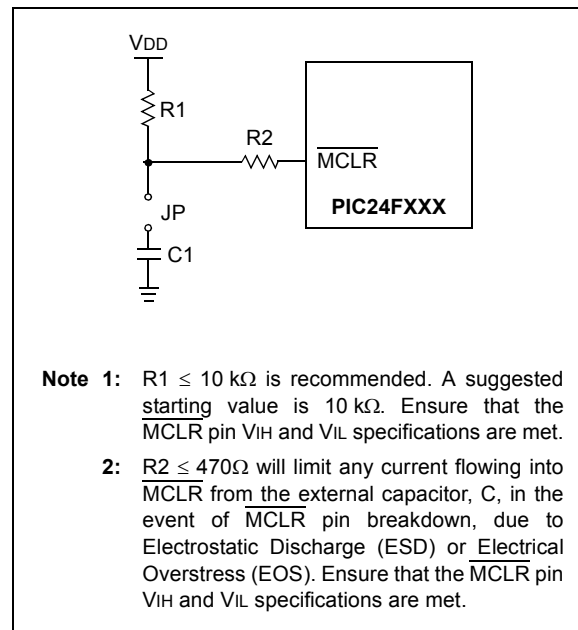
## 2.3 Master Clear ( $\overline{\text{MCLR}}$ ) Pin

The  $\overline{\text{MCLR}}$  pin provides two specific device functions: device Reset, and device programming and debugging. If programming and debugging are not required in the end application, a direct connection to VDD may be all that is required. The addition of other components, to help increase the application's resistance to spurious Resets from voltage sags, may be beneficial. A typical configuration is shown in Figure 2-1. Other circuit designs may be implemented, depending on the application's requirements.

During programming and debugging, the resistance and capacitance that can be added to the pin must be considered. Device programmers and debuggers drive the  $\overline{\text{MCLR}}$  pin. Consequently, specific voltage levels ( $V_{IH}$  and  $V_{IL}$ ) and fast signal transitions must not be adversely affected. Therefore, specific values of R1 and C1 will need to be adjusted based on the application and PCB requirements. For example, it is recommended that the capacitor, C1, be isolated from the  $\overline{\text{MCLR}}$  pin during programming and debugging operations by using a jumper (Figure 2-2). The jumper is replaced for normal run-time operations.

Any components associated with the  $\overline{\text{MCLR}}$  pin should be placed within 0.25 inch (6 mm) of the pin.

**FIGURE 2-2: EXAMPLE OF  $\overline{\text{MCLR}}$  PIN CONNECTIONS**



# PIC24FJ256GA110 FAMILY

## 2.4 Voltage Regulator Pins (ENVREG/DISVREG and VCAP/VDDCORE)

**Note:** This section applies only to PIC24F J devices with an on-chip voltage regulator.

The on-chip voltage regulator enable/disable pin (ENVREG or DISVREG, depending on the device family) must always be connected directly to either a supply voltage or to ground. The particular connection is determined by whether or not the regulator is to be used:

- For ENVREG, tie to VDD to enable the regulator, or to ground to disable the regulator
- For DISVREG, tie to ground to enable the regulator or to VDD to disable the regulator

Refer to [Section 25.2 “On-Chip Voltage Regulator”](#) for details on connecting and using the on-chip regulator.

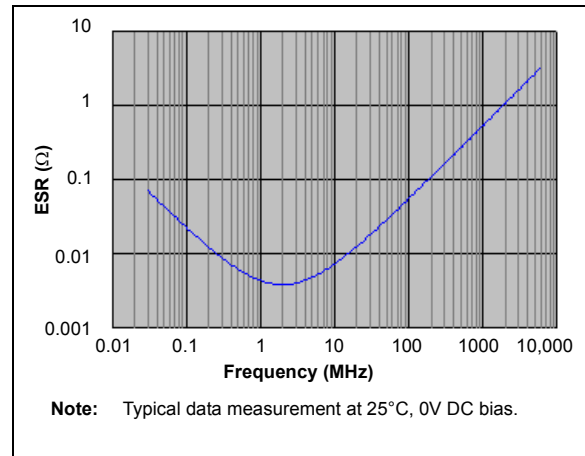
When the regulator is enabled, a low-ESR (< 5Ω) capacitor is required on the VCAP/VDDCORE pin to stabilize the voltage regulator output voltage. The VCAP/VDDCORE pin must not be connected to VDD and must use a capacitor of 10 μF connected to ground. The type can be ceramic or tantalum. Suitable examples of capacitors are shown in [Table 2-1](#). Capacitors with equivalent specification can be used.

Designers may use [Figure 2-3](#) to evaluate ESR equivalence of candidate devices.

The placement of this capacitor should be close to VCAP/VDDCORE. It is recommended that the trace length not exceed 0.25 inch (6 mm). Refer to [Section 28.0 “Electrical Characteristics”](#) for additional information.

When the regulator is disabled, the VCAP/VDDCORE pin must be tied to a voltage supply at the VDDCORE level. Refer to [Section 28.0 “Electrical Characteristics”](#) for information on VDD and VDDCORE.

**FIGURE 2-3: FREQUENCY vs. ESR PERFORMANCE FOR SUGGESTED VCAP**



**TABLE 2-1: SUITABLE CAPACITOR EQUIVALENTS**

Make	Part #	Nominal Capacitance	Base Tolerance	Rated Voltage	Temp. Range
TDK	C3216X7R1C106K	10 μF	±10%	16V	-55 to +125°C
TDK	C3216X5R1C106K	10 μF	±10%	16V	-55 to +85°C
Panasonic	ECJ-3YX1C106K	10 μF	±10%	16V	-55 to +125°C
Panasonic	ECJ-4YB1C106K	10 μF	±10%	16V	-55 to +85°C
Murata	GRM32DR71C106KA01L	10 μF	±10%	16V	-55 to +125°C
Murata	GRM31CR61C106KC31L	10 μF	±10%	16V	-55 to +85°C

# PIC24FJ256GA110 FAMILY

## 2.4.1 CONSIDERATIONS FOR CERAMIC CAPACITORS

In recent years, large value, low-voltage, surface-mount ceramic capacitors have become very cost effective in sizes up to a few tens of microfarad. The low-ESR, small physical size and other properties make ceramic capacitors very attractive in many types of applications.

Ceramic capacitors are suitable for use with the internal voltage regulator of this microcontroller. However, some care is needed in selecting the capacitor to ensure that it maintains sufficient capacitance over the intended operating range of the application.

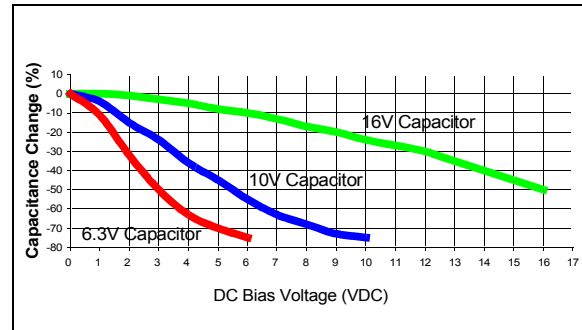
Typical low-cost, 10  $\mu\text{F}$  ceramic capacitors are available in X5R, X7R and Y5V dielectric ratings (other types are also available, but are less common). The initial tolerance specifications for these types of capacitors are often specified as  $\pm 10\%$  to  $\pm 20\%$  (X5R and X7R), or  $-20\%/+80\%$  (Y5V). However, the effective capacitance that these capacitors provide in an application circuit will also vary based on additional factors, such as the applied DC bias voltage and the temperature. The total in-circuit tolerance is, therefore, much wider than the initial tolerance specification.

The X5R and X7R capacitors typically exhibit satisfactory temperature stability (ex:  $\pm 15\%$  over a wide temperature range, but consult the manufacturer's data sheets for exact specifications). However, Y5V capacitors typically have extreme temperature tolerance specifications of  $+22\%/ -82\%$ . Due to the extreme temperature tolerance, a 10  $\mu\text{F}$  nominal rated Y5V type capacitor may not deliver enough total capacitance to meet minimum internal voltage regulator stability and transient response requirements. Therefore, Y5V capacitors are not recommended for use with the internal regulator if the application must operate over a wide temperature range.

In addition to temperature tolerance, the effective capacitance of large value ceramic capacitors can vary substantially, based on the amount of DC voltage applied to the capacitor. This effect can be very significant, but is often overlooked or is not always documented.

Typical DC bias voltage vs. capacitance graph for X7R type capacitors is shown in [Figure 2-4](#).

**FIGURE 2-4: DC BIAS VOLTAGE vs. CAPACITANCE CHARACTERISTICS**



When selecting a ceramic capacitor to be used with the internal voltage regulator, it is suggested to select a high-voltage rating, so that the operating voltage is a small percentage of the maximum rated capacitor voltage. For example, choose a ceramic capacitor rated at 16V for the 2.5V or 1.8V core voltage. Suggested capacitors are shown in [Table 2-1](#).

## 2.5 ICSP Pins

The PGECx and PGEDx pins are used for In-Circuit Serial Programming (ICSP) and debugging purposes. It is recommended to keep the trace length between the ICSP connector and the ICSP pins on the device as short as possible. If the ICSP connector is expected to experience an ESD event, a series resistor is recommended, with the value in the range of a few tens of ohms, not to exceed 100 $\Omega$ .

Pull-up resistors, series diodes and capacitors on the PGECx and PGEDx pins are not recommended as they will interfere with the programmer/debugger communications to the device. If such discrete components are an application requirement, they should be removed from the circuit during programming and debugging. Alternatively, refer to the AC/DC characteristics and timing requirements information in the respective device Flash programming specification for information on capacitive loading limits and pin input voltage high ( $V_{IH}$ ) and input low ( $V_{IL}$ ) requirements.

For device emulation, ensure that the "Communication Channel Select" (i.e., PGECx/PGEDx pins), programmed into the device, matches the physical connections for the ICSP to the Microchip debugger/emulator tool.

For more information on available Microchip development tools connection requirements, refer to [Section 27.0 "Development Support"](#).

## 2.6 External Oscillator Pins

Many microcontrollers have options for at least two oscillators: a high-frequency primary oscillator and a low-frequency secondary oscillator (refer to [Section 8.0 “Oscillator Configuration”](#) for details).

The oscillator circuit should be placed on the same side of the board as the device. Place the oscillator circuit close to the respective oscillator pins with no more than 0.5 inch (12 mm) between the circuit components and the pins. The load capacitors should be placed next to the oscillator itself, on the same side of the board.

Use a grounded copper pour around the oscillator circuit to isolate it from surrounding circuits. The grounded copper pour should be routed directly to the MCU ground. Do not run any signal traces or power traces inside the ground pour. Also, if using a two-sided board, avoid any traces on the other side of the board where the crystal is placed.

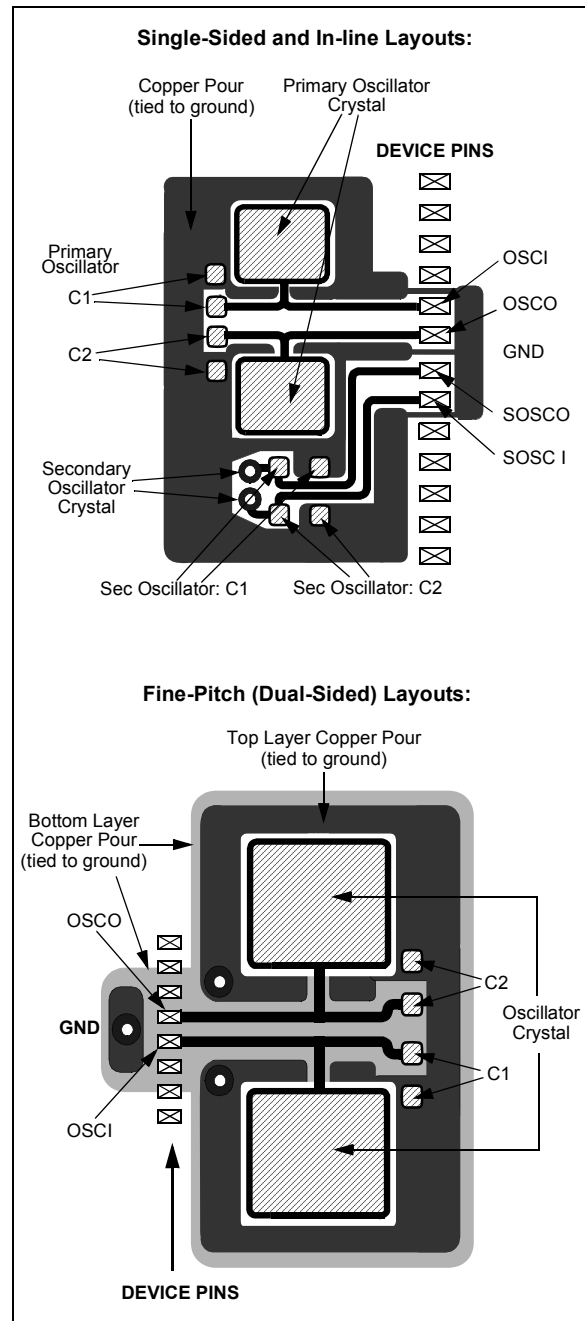
Layout suggestions are shown in [Figure 2-5](#). In-line packages may be handled with a single-sided layout that completely encompasses the oscillator pins. With fine-pitch packages, it is not always possible to completely surround the pins and components. A suitable solution is to tie the broken guard sections to a mirrored ground layer. In all cases, the guard trace(s) must be returned to ground.

In planning the application’s routing and I/O assignments, ensure that adjacent port pins, and other signals in close proximity to the oscillator, are benign (i.e., free of high frequencies, short rise and fall times and other similar noise).

For additional information and design guidance on oscillator circuits, please refer to these Microchip Application Notes, available at the corporate website ([www.microchip.com](http://www.microchip.com)):

- AN826, “Crystal Oscillator Basics and Crystal Selection for rPIC™ and PICmicro® Devices”
- AN849, “Basic PICmicro® Oscillator Design”
- AN943, “Practical PICmicro® Oscillator Analysis and Design”
- AN949, “Making Your Oscillator Work”

**FIGURE 2-5: SUGGESTED PLACEMENT OF THE OSCILLATOR CIRCUIT**



# PIC24FJ256GA110 FAMILY

---

## 2.7 Configuration of Analog and Digital Pins During ICSP Operations

If an ICSP compliant emulator is selected as a debugger, it automatically initializes all of the A/D input pins (ANx) as “digital” pins. Depending on the particular device, this is done by setting all bits in the ADxPCFG register(s) or clearing all bits in the ANSx registers.

All PIC24F devices will have either one or more ADxPCFG registers or several ANSx registers (one for each port); no device will have both.

The bits in these registers that correspond to the A/D pins that initialized the emulator must not be changed by the user application firmware; otherwise, communication errors will result between the debugger and the device.

If your application needs to use certain A/D pins as analog input pins during the debug session, the user application must modify the appropriate bits during initialization of the ADC module, as follows:

- For devices with an ADxPCFG register, clear the bits corresponding to the pin(s) to be configured as analog. Do not change any other bits, particularly those corresponding to the PGECx/PGEDx pair, at any time.
- For devices with ANSx registers, set the bits corresponding to the pin(s) to be configured as analog. Do not change any other bits, particularly those corresponding to the PGECx/PGEDx pair, at any time.

When a Microchip debugger/emulator is used as a programmer, the user application firmware must correctly configure the ADxPCFG or ANSx registers. Automatic initialization of this register is only done during debugger operation. Failure to correctly configure the register(s) will result in all A/D pins being recognized as analog input pins, resulting in the port value being read as a logic '0', which may affect user application functionality.

## 2.8 Unused I/Os

Unused I/O pins should be configured as outputs and driven to a logic low state. Alternatively, connect a 1 k $\Omega$  to 10 k $\Omega$  resistor to Vss on unused pins and drive the output to logic low.

## 3.0 CPU

**Note:** This data sheet summarizes the features of this group of PIC24F devices. It is not intended to be a comprehensive reference source. For more information on the CPU, refer to “CPU” ([www.microchip.com/DS39703](http://www.microchip.com/DS39703)) in the “dsPIC33/PIC24 Family Reference Manual”. The information in this data sheet supersedes the information in the FRM.

The PIC24F CPU has a 16-bit (data), modified Harvard architecture with an enhanced instruction set and a 24-bit instruction word with a variable length opcode field. The Program Counter (PC) is 23 bits wide and addresses up to 4M instructions of user program memory space. A single-cycle instruction prefetch mechanism is used to help maintain throughput and provides predictable execution. All instructions execute in a single cycle, with the exception of instructions that change the program flow, the double-word move (MOV.D) instruction and the table instructions. Overhead-free program loop constructs are supported using the REPEAT instructions, which are interruptible at any point.

PIC24F devices have sixteen, 16-bit Working registers in the programmer’s model. Each of the Working registers can act as a data, address or address offset register. The 16th Working register (W15) operates as a Software Stack Pointer for interrupts and calls.

The upper 32 Kbytes of the Data Space memory map can optionally be mapped into program space at any 16K word boundary defined by the 8-bit Program Space Visibility Page Address (PSVPAG) register. The program to Data Space mapping feature lets any instruction access program space as if it were Data Space.

The Instruction Set Architecture (ISA) has been significantly enhanced beyond that of the PIC18, but maintains an acceptable level of backward compatibility. All PIC18 instructions and addressing modes are supported either directly or through simple macros. Many of the ISA enhancements have been driven by compiler efficiency needs.

The core supports Inherent (no operand), Relative, Literal, Memory Direct and three groups of addressing modes. All modes support Register Direct and various Register Indirect modes. Each group offers up to seven addressing modes. Instructions are associated with predefined addressing modes depending upon their functional requirements.

For most instructions, the core is capable of executing a data (or program data) memory read, a Working register (data) read, a data memory write and a program (instruction) memory read per instruction cycle. As a result, three parameter instructions can be supported, allowing trinary operations (that is,  $A + B = C$ ) to be executed in a single cycle.

A high-speed, 17-bit by 17-bit multiplier has been included to significantly enhance the core arithmetic capability and throughput. The multiplier supports Signed, Unsigned and Mixed mode, 16-bit by 16-bit or 8-bit by 8-bit integer multiplication. All multiply instructions execute in a single cycle.

The 16-bit ALU has been enhanced with integer divide assist hardware that supports an iterative non-restoring divide algorithm. It operates in conjunction with the REPEAT instruction looping mechanism and a selection of iterative divide instructions to support 32-bit (or 16-bit), divided by 16-bit, integer signed and unsigned division. All divide operations require 19 cycles to complete, but are interruptible at any cycle boundary.

The PIC24F has a vectored exception scheme with up to eight sources of non-maskable traps and up to 118 interrupt sources. Each interrupt source can be assigned to one of seven priority levels.

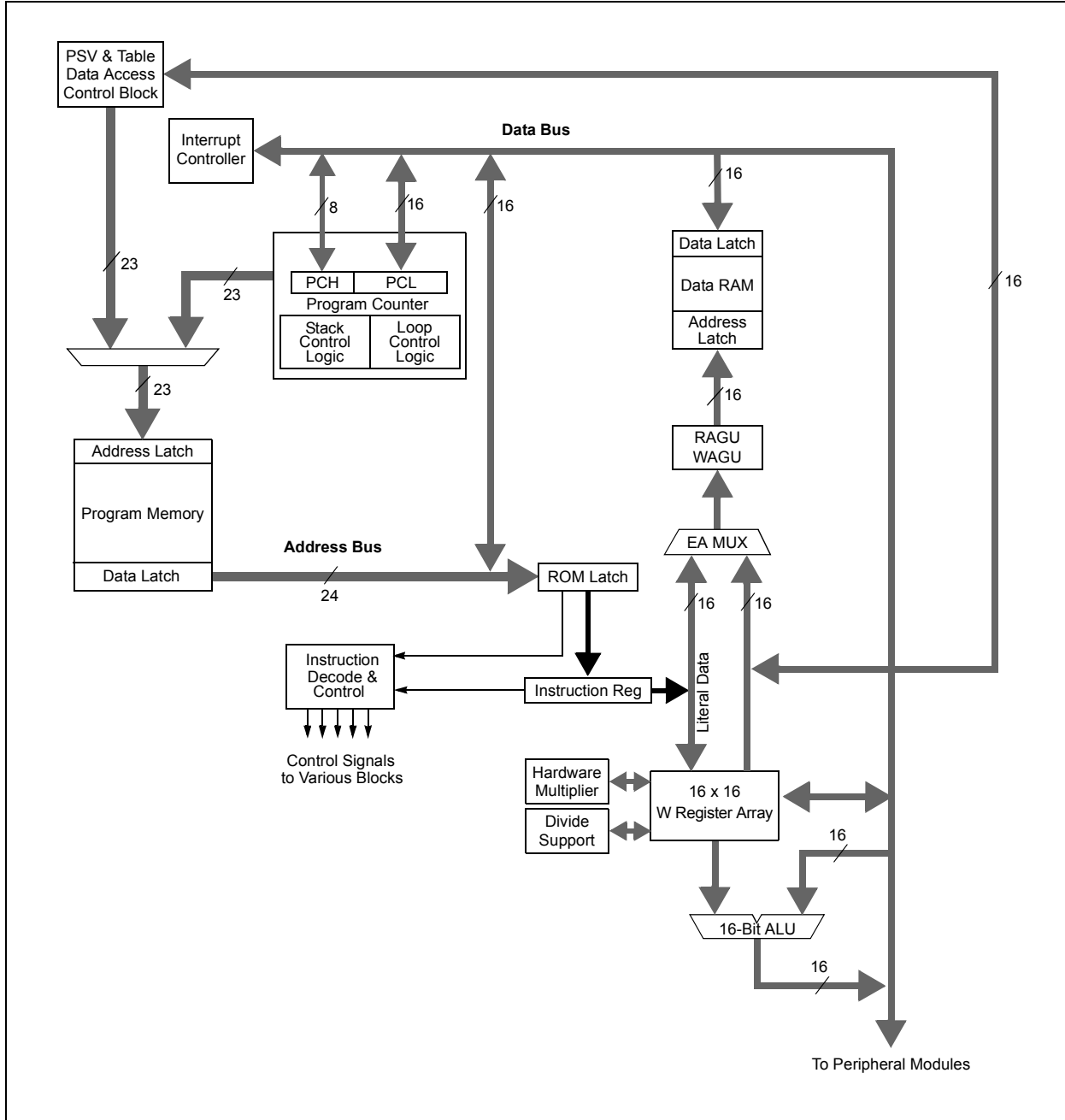
A block diagram of the CPU is shown in [Figure 3-1](#).

### 3.1 Programmer’s Model

The programmer’s model for the PIC24F is shown in [Figure 3-2](#). All registers in the programmer’s model are memory-mapped and can be manipulated directly by instructions. A description of each register is provided in [Table 3-1](#). All registers associated with the programmer’s model are memory-mapped.

# PIC24FJ256GA110 FAMILY

FIGURE 3-1: PIC24F CPU CORE BLOCK DIAGRAM

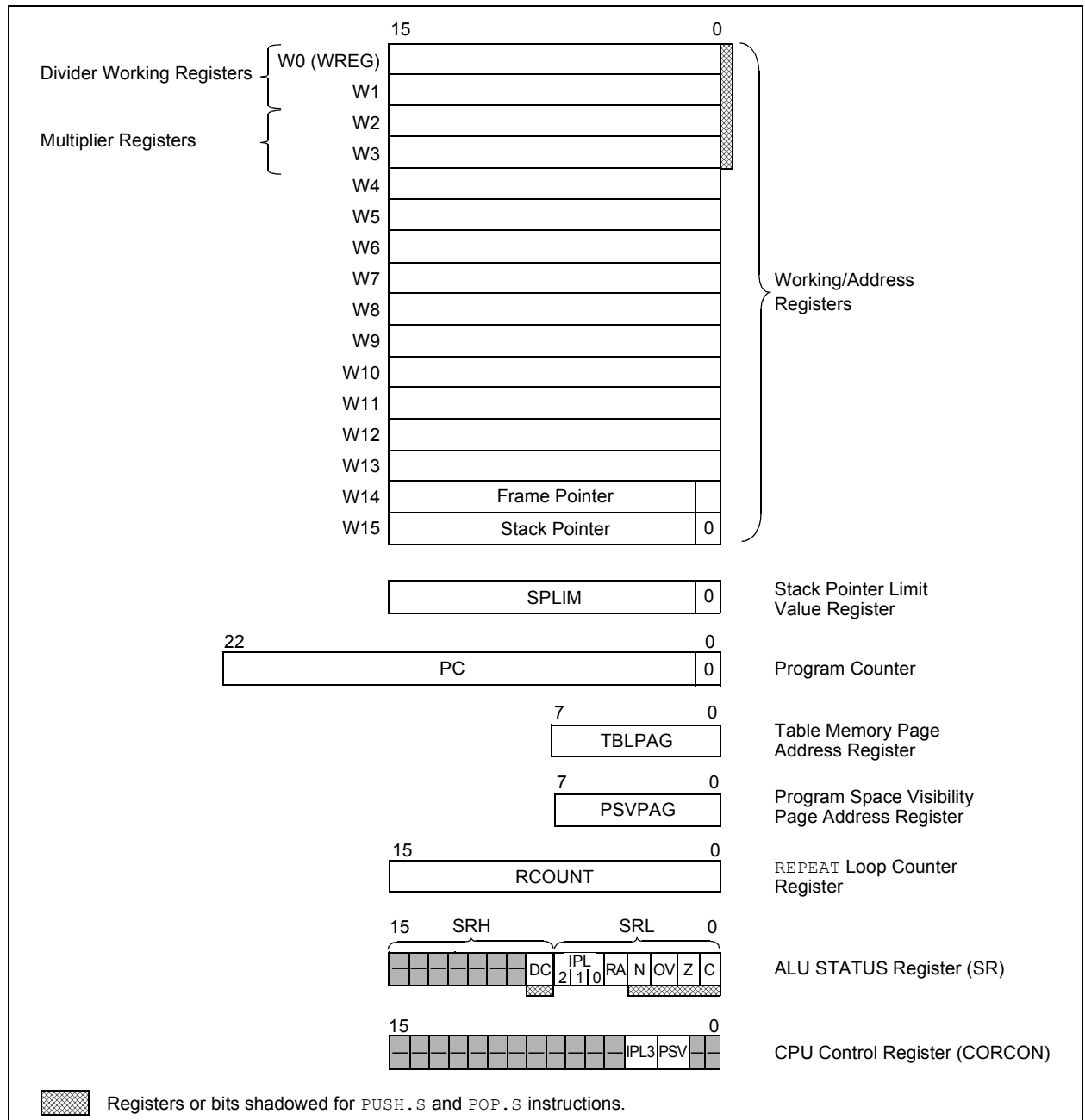


# PIC24FJ256GA110 FAMILY

**TABLE 3-1: CPU CORE REGISTERS**

Register(s) Name	Description
W0 through W15	Working Register Array
PC	23-Bit Program Counter
SR	ALU STATUS Register
SPLIM	Stack Pointer Limit Value Register
TBLPAG	Table Memory Page Address Register
PSVPAG	Program Space Visibility Page Address Register
RCOUNT	Repeat Loop Counter Register
CORCON	CPU Control Register

**FIGURE 3-2: PROGRAMMER'S MODEL**



# PIC24FJ256GA110 FAMILY

## 3.2 CPU Control Registers

### REGISTER 3-1: SR: ALU STATUS REGISTER

U-0	U-0	U-0	U-0	U-0	U-0	U-0	R/W-0
—	—	—	—	—	—	—	DC
bit 15							bit 8

R/W-0 <sup>(1)</sup>	R/W-0 <sup>(1)</sup>	R/W-0 <sup>(1)</sup>	R-0	R/W-0	R/W-0	R/W-0	R/W-0
IPL2 <sup>(2)</sup>	IPL1 <sup>(2)</sup>	IPL0 <sup>(2)</sup>	RA	N	OV	Z	C
bit 7							bit 0

#### Legend:

R = Readable bit	W = Writable bit	U = Unimplemented bit, read as '0'
-n = Value at POR	'1' = Bit is set	'0' = Bit is cleared
		x = Bit is unknown

- bit 15-9     **Unimplemented:** Read as '0'
- bit 8       **DC:** ALU Half Carry/Borrow bit  
 1 = A carry-out from the 4th low-order bit (for byte-sized data) or 8th low-order bit (for word-sized data) of the result occurred  
 0 = No carry-out from the 4th or 8th low-order bit of the result has occurred
- bit 7-5     **IPL[2:0]:** CPU Interrupt Priority Level Status bits<sup>(1,2)</sup>  
 111 = CPU Interrupt Priority Level is 7 (15); user interrupts disabled  
 110 = CPU Interrupt Priority Level is 6 (14)  
 101 = CPU Interrupt Priority Level is 5 (13)  
 100 = CPU Interrupt Priority Level is 4 (12)  
 011 = CPU Interrupt Priority Level is 3 (11)  
 010 = CPU Interrupt Priority Level is 2 (10)  
 001 = CPU Interrupt Priority Level is 1 (9)  
 000 = CPU Interrupt Priority Level is 0 (8)
- bit 4       **RA:** REPEAT Loop Active bit  
 1 = REPEAT loop in progress  
 0 = REPEAT loop not in progress
- bit 3       **N:** ALU Negative bit  
 1 = Result was negative  
 0 = Result was non-negative (zero or positive)
- bit 2       **OV:** ALU Overflow bit  
 1 = Overflow occurred for signed (2's complement) arithmetic in this arithmetic operation  
 0 = No overflow has occurred
- bit 1       **Z:** ALU Zero bit  
 1 = An operation which effects the Z bit has set it at some time in the past  
 0 = The most recent operation which effects the Z bit has cleared it (i.e., a non-zero result)
- bit 0       **C:** ALU Carry/Borrow bit  
 1 = A carry-out from the Most Significant bit of the result occurred  
 0 = No carry-out from the Most Significant bit of the result occurred

- Note 1:** The IPLx Status bits are read-only when NSTDIS (INTCON1[15]) = 1.  
**Note 2:** The IPLx Status bits are concatenated with the IPL3 bit (CORCON[3]) to form the CPU Interrupt Priority Level (IPL). The value in parentheses indicates the IPL when IPL3 = 1.

# PIC24FJ256GA110 FAMILY

## REGISTER 3-2: CORCON: CPU CONTROL REGISTER

U-0	U-0	U-0	U-0	U-0	U-0	U-0	U-0
—	—	—	—	—	—	—	—
bit 15							bit 8

U-0	U-0	U-0	U-0	R/C-0	R/W-0	U-0	U-0
—	—	—	—	IPL3 <sup>(1)</sup>	PSV	—	—
bit 7							bit 0

<b>Legend:</b>	C = Clearable bit	U = Unimplemented bit, read as '0'
R = Readable bit	W = Writable bit	'0' = Bit is cleared
-n = Value at POR	'1' = Bit is set	x = Bit is unknown

bit 15-4     **Unimplemented:** Read as '0'

bit 3       **IPL3:** CPU Interrupt Priority Level Status bit<sup>(1)</sup>  
             1 = CPU Interrupt Priority Level is greater than 7  
             0 = CPU Interrupt Priority Level is 7 or less

bit 2       **PSV:** Program Space Visibility in Data Space Enable bit  
             1 = Program space visible in Data Space  
             0 = Program space not visible in Data Space

bit 1-0     **Unimplemented:** Read as '0'

**Note 1:** User interrupts are disabled when IPL3 = 1.

# PIC24FJ256GA110 FAMILY

## 3.3 Arithmetic Logic Unit (ALU)

The PIC24F ALU is 16 bits wide and is capable of addition, subtraction, bit shifts and logic operations. Unless otherwise mentioned, arithmetic operations are two's complement in nature. Depending on the operation, the ALU may affect the values of the Carry (C), Zero (Z), Negative (N), Overflow (OV) and Digit Carry (DC) Status bits in the SR register. The C and DC Status bits operate as Borrow and Digit Borrow bits, respectively, for subtraction operations.

The ALU can perform 8-bit or 16-bit operations, depending on the mode of the instruction that is used. Data for the ALU operation can come from the W register array, or data memory, depending on the addressing mode of the instruction. Likewise, output data from the ALU can be written to the W register array or a data memory location.

The PIC24F CPU incorporates hardware support for both multiplication and division. This includes a dedicated hardware multiplier and support hardware for 16-bit divisor division.

### 3.3.1 MULTIPLIER

The ALU contains a high-speed, 17-bit x 17-bit multiplier. It supports unsigned, signed or mixed sign operation in several multiplication modes:

1. 16-bit x 16-bit signed
2. 16-bit x 16-bit unsigned
3. 16-bit signed x 5-bit (literal) unsigned
4. 16-bit unsigned x 16-bit unsigned
5. 16-bit unsigned x 5-bit (literal) unsigned
6. 16-bit unsigned x 16-bit signed
7. 8-bit unsigned x 8-bit unsigned

### 3.3.2 DIVIDER

The divide block supports signed and unsigned integer divide operations with the following data sizes:

1. 32-bit signed/16-bit signed divide
2. 32-bit unsigned/16-bit unsigned divide
3. 16-bit signed/16-bit signed divide
4. 16-bit unsigned/16-bit unsigned divide

The quotient for all divide instructions ends up in W0 and the remainder in W1. Sixteen-bit signed and unsigned `DIV` instructions can specify any W register for both the 16-bit divisor (Wn), and any W register (aligned) pair (W(m + 1):Wm) for the 32-bit dividend. The divide algorithm takes one cycle per bit of divisor, so both 32-bit/16-bit and 16-bit/16-bit instructions take the same number of cycles to execute.

### 3.3.3 MULTIBIT SHIFT SUPPORT

The PIC24F ALU supports both single bit and single-cycle, multi-bit arithmetic and logic shifts. Multi-bit shifts are implemented using a shifter block, capable of performing up to a 15-bit arithmetic right shift, or up to a 15-bit left shift, in a single cycle. All multi-bit shift instructions only support Register Direct Addressing for both the operand source and result destination.

A full summary of instructions that use the shift operation is provided below in [Table 3-2](#).

**TABLE 3-2: INSTRUCTIONS THAT USE THE SINGLE AND MULTIBIT SHIFT OPERATION**

Instruction	Description
ASR	Arithmetic shift right source register by one or more bits.
SL	Shift left source register by one or more bits.
LSR	Logical shift right source register by one or more bits.

# PIC24FJ256GA110 FAMILY

---

## 4.0 MEMORY ORGANIZATION

**Note:** This data sheet summarizes the features of this group of PIC24F devices. It is not intended to be a comprehensive reference source. For more information, refer to “**PIC24F Flash Program Memory**” ([www.microchip.com/DS30009715](http://www.microchip.com/DS30009715)) and “**PIC24F Data Memory**” ([www.microchip.com/DS30009717](http://www.microchip.com/DS30009717)) in the “*dsPIC33/PIC24 Family Reference Manual*”. The information in this data sheet supersedes the information in the FRM.

As Harvard architecture devices, PIC24F microcontrollers feature separate program and data memory spaces and busses. This architecture also allows the direct access of program memory from the Data Space during code execution.

## 4.1 Program Address Space

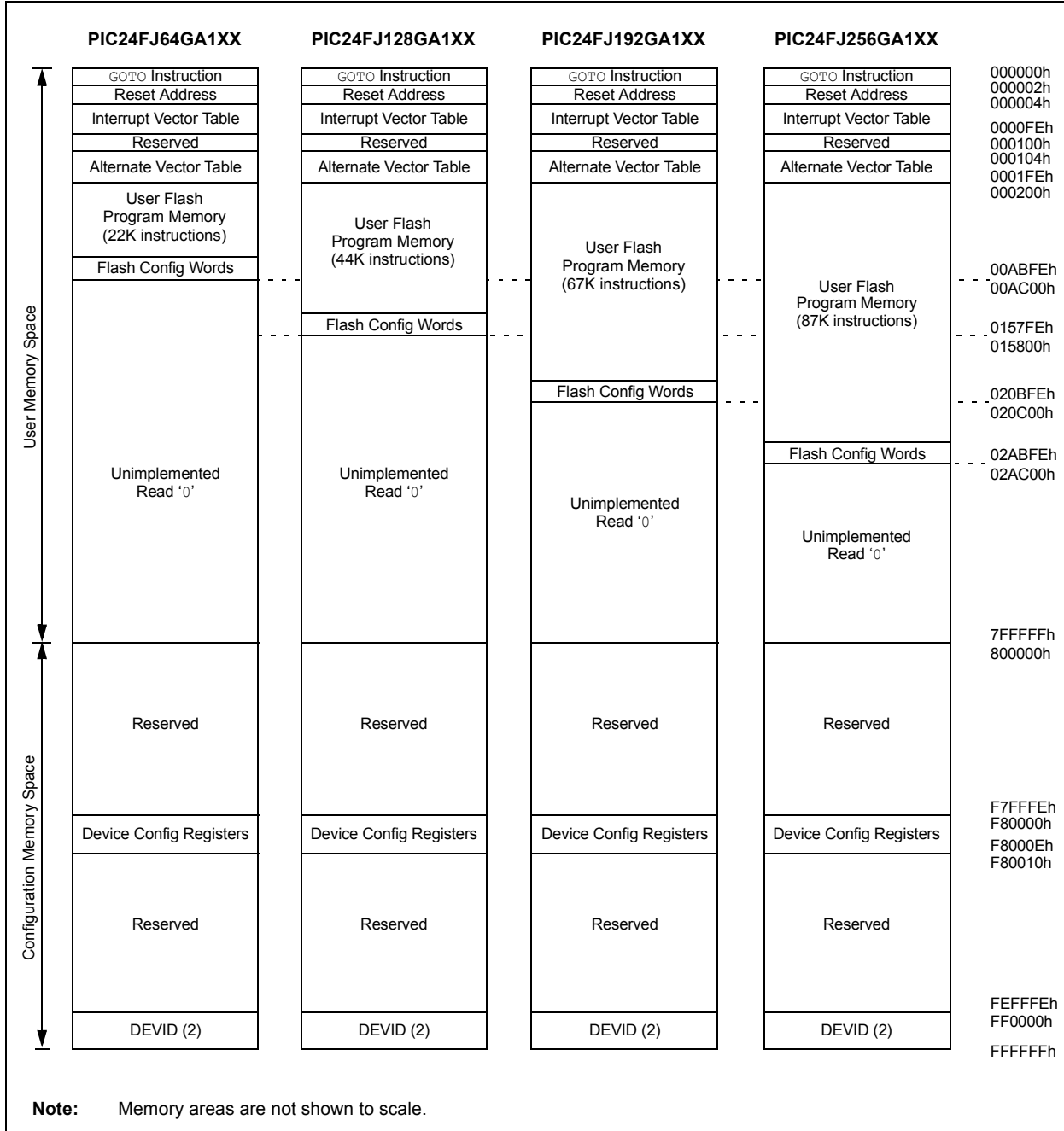
The program address memory space of the PIC24FJ256GA110 family devices is 4M instructions. The space is addressable by a 24-bit value derived from either the 23-bit Program Counter (PC) during program execution, or from table operation or Data Space remapping, as described in [Section 4.3 “Interfacing Program and Data Memory Spaces”](#).

User access to the program memory space is restricted to the lower half of the address range (000000h to 7FFFFFFh). The exception is the use of `TBLRD/TBLWT` operations which use `TBLPAG[7]` to permit access to the Configuration bits and Device ID sections of the configuration memory space.

Memory maps for the PIC24FJ256GA110 family of devices are shown in [Figure 4-1](#).

# PIC24FJ256GA110 FAMILY

**FIGURE 4-1: PROGRAM SPACE MEMORY MAP FOR PIC24FJ256GA110 FAMILY DEVICES**



# PIC24FJ256GA110 FAMILY

## 4.1.1 PROGRAM MEMORY ORGANIZATION

The program memory space is organized in word-addressable blocks. Although it is treated as 24 bits wide, it is more appropriate to think of each address of the program memory as a lower and upper word, with the upper byte of the upper word being unimplemented. The lower word always has an even address, while the upper word has an odd address (Figure 4-2).

Program memory addresses are always word-aligned on the lower word and addresses are incremented or decremented by two during code execution. This arrangement also provides compatibility with data memory space addressing and makes it possible to access data in the program memory space.

## 4.1.2 HARD MEMORY VECTORS

All PIC24F devices reserve the addresses between 00000h and 000200h for hard-coded program execution vectors. A hardware Reset vector is provided to redirect code execution from the default value of the PC on device Reset to the actual start of code. A GOTO instruction is programmed by the user at 000000h with the actual address for the start of code at 000002h.

PIC24F devices also have two interrupt vector tables, located from 000004h to 0000FFh and 000100h to 0001FFh. These vector tables allow each of the many device interrupt sources to be handled by separate ISRs. A more detailed discussion of the interrupt vector tables is provided in Section 7.1 “Interrupt Vector Table”.

## 4.1.3 FLASH CONFIGURATION WORDS

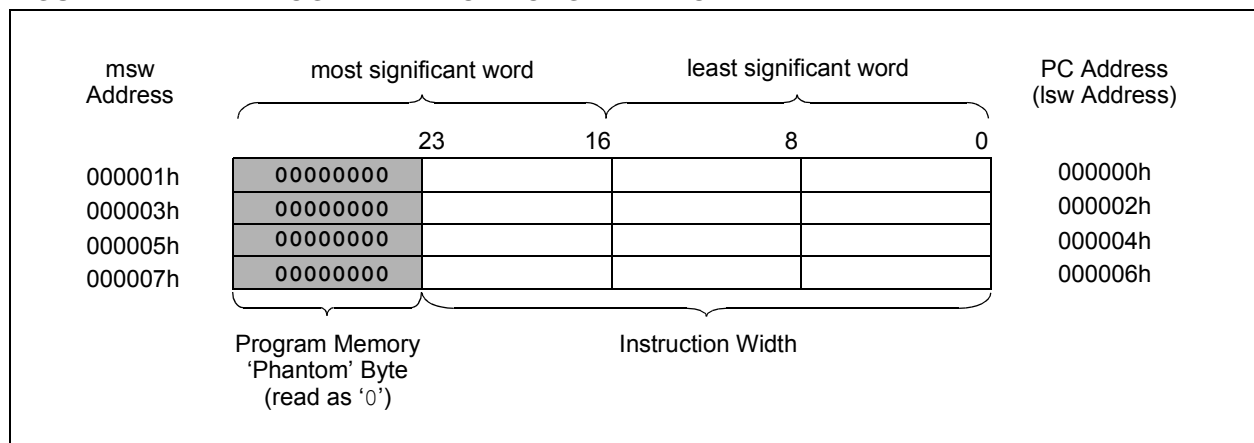
In PIC24FJ256GA110 family devices, the top three words of on-chip program memory are reserved for configuration information. On device Reset, the configuration information is copied into the appropriate Configuration registers. The addresses of the Flash Configuration Word for devices in the PIC24FJ256GA110 family are shown in Table 4-1. Their location in the memory map is shown with the other memory vectors in Figure 4-1.

The Configuration Words in program memory are a compact format. The actual Configuration bits are mapped in several different registers in the configuration memory space. Their order in the Flash Configuration Words do not reflect a corresponding arrangement in the configuration space. Additional details on the device Configuration Words are provided in Section 25.1 “Configuration Bits”.

**TABLE 4-1: FLASH CONFIGURATION WORDS FOR PIC24FJ256GA110 FAMILY DEVICES**

Device	Program Memory (Words)	Configuration Word Addresses
PIC24FJ64GA	22,016	00ABFEh: 00AC00h
PIC24FJ128GA	44,032	0157FAh: 0157FEh
PIC24FJ192GA	67,072	020BFAh: 020BFEh
PIC24FJ256GA	87,552	02ABFAh: 02ABFEh

**FIGURE 4-2: PROGRAM MEMORY ORGANIZATION**



# PIC24FJ256GA110 FAMILY

## 4.2 Data Address Space

The PIC24F core has a separate, 16-bit wide data memory space, addressable as a single linear range. The Data Space is accessed using two Address Generation Units (AGUs), one each for read and write operations. The Data Space memory map is shown in [Figure 4-3](#).

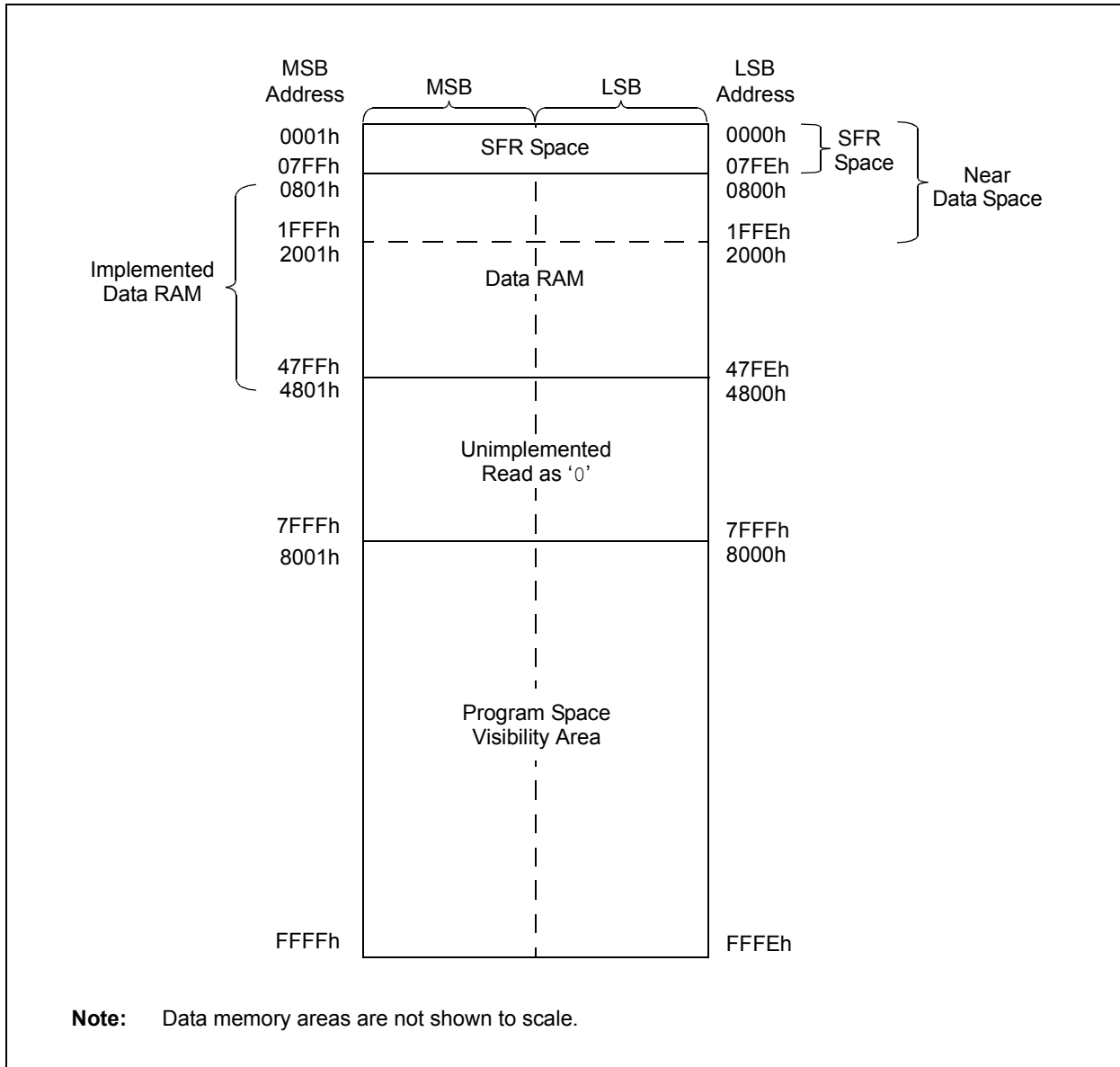
All Effective Addresses (EAs) in the data memory space are 16 bits wide and point to bytes within the Data Space. This gives a Data Space address range of 64 Kbytes or 32K words. The lower half of the data memory space (that is, when EA[15] = 0) is used for implemented memory addresses, while the upper half (EA[15] = 1) is reserved for the Program Space Visibility area (see [Section 4.3.3 “Reading Data from Program Memory Using Program Space Visibility”](#)).

PIC24FJ256GA110 family devices implement a total of 16 Kbytes of data memory. Should an EA point to a location outside of this area, an all zero word or byte will be returned.

### 4.2.1 DATA SPACE WIDTH

The data memory space is organized in byte-addressable, 16-bit wide blocks. Data are aligned in data memory and registers as 16-bit words, but all Data Space EAs resolve to bytes. The Least Significant Bytes (LSBs) of each word have even addresses, while the Most Significant Bytes (MSBs) have odd addresses.

**FIGURE 4-3: DATA SPACE MEMORY MAP FOR PIC24FJ256GA110 FAMILY DEVICES**



# PIC24FJ256GA110 FAMILY

## 4.2.2 DATA MEMORY ORGANIZATION AND ALIGNMENT

To maintain backward compatibility with PIC® devices and improve Data Space memory usage efficiency, the PIC24F instruction set supports both word and byte operations. As a consequence of byte accessibility, all Effective Address (EA) calculations are internally scaled to step through word-aligned memory. For example, the core recognizes that Post-Modified Register Indirect Addressing mode [Ws++] will result in a value of Ws + 1 for byte operations and Ws + 2 for word operations.

Data byte reads will read the complete word which contains the byte, using the LSb of any EA to determine which byte to select. The selected byte is placed onto the LSB of the data path. That is, data memory and registers are organized as two parallel, byte-wide entities with shared (word) address decode, but separate write lines. Data byte writes only write to the corresponding side of the array or register which matches the byte address.

All word accesses must be aligned to an even address. Misaligned word data fetches are not supported, so care must be taken when mixing byte and word operations or translating from 8-bit MCU code. If a misaligned read or write is attempted, an address error trap will be generated. If the error occurred on a read, the instruction underway is completed; if it occurred on a write, the instruction will be executed but the write will not occur. In either case, a trap is then executed, allowing the system and/or user to examine the machine state prior to execution of the address Fault.

All byte loads into any W register are loaded into the Least Significant Byte. The Most Significant Byte is not modified.

A Sign-Extend (SE) instruction is provided to allow users to translate 8-bit signed data to 16-bit signed values. Alternatively, for 16-bit unsigned data, users can clear the MSB of any W register by executing a Zero-Extend (ZE) instruction on the appropriate address.

Although most instructions are capable of operating on word or byte data sizes, it should be noted that some instructions operate only on words.

## 4.2.3 NEAR DATA SPACE

The 8-Kbyte area between 0000h and 1FFFh is referred to as the Near Data Space. Locations in this space are directly addressable via a 13-bit absolute address field within all memory direct instructions. The remainder of the Data Space is indirectly addressable. Additionally, the whole Data Space is addressable using MOV instructions, which support Memory Direct Addressing with a 16-bit address field.

## 4.2.4 SFR SPACE

The first 2 Kbytes of the Near Data Space, from 0000h to 07FFh, are primarily occupied with Special Function Registers (SFRs). These are used by the PIC24F core and peripheral modules for controlling the operation of the device.

SFRs are distributed among the modules that they control and are generally grouped together by module. Much of the SFR space contains unused addresses; these are read as '0'. A diagram of the SFR space, showing where SFRs are actually implemented, is shown in Table 4-2. Each implemented area indicates a 32-byte region where at least one address is implemented as an SFR. A complete listing of implemented SFRs, including their addresses, is shown in Tables 4-3 through 4-29.

**TABLE 4-2: IMPLEMENTED REGIONS OF SFR DATA SPACE**

	SFR Space Address							
	xx00	xx20	xx40	xx60	xx80	xxA0	xxC0	xxE0
000h	Core			ICN	Interrupts			—
100h	Timers		Capture		Compare			
200h	I <sup>2</sup> C	UART	SPI/UART	SPI/I <sup>2</sup> C	SPI	UART	I/O	
300h	A/D	A/D/CTMU	—	—	—	—	—	—
400h	—	—	—	—	—	—	—	—
500h	—	—	—	—	—	—	—	—
600h	PMP	RTC/Comp	CRC	—	PPS			—
700h	—	—	System	NVM/PMD	—	—	—	—

**Legend:** — = No implemented SFRs in this block

**TABLE 4-3: CPU CORE REGISTERS MAP**

File Name	Addr	Bit 15	Bit 14	Bit 13	Bit 12	Bit 11	Bit 10	Bit 9	Bit 8	Bit 7	Bit 6	Bit 5	Bit 4	Bit 3	Bit 2
WREG0	0000														
WREG1	0002														
WREG2	0004														
WREG3	0006														
WREG4	0008														
WREG5	000A														
WREG6	000C														
WREG7	000E														
WREG8	0010														
WREG9	0012														
WREG10	0014														
WREG11	0016														
WREG12	0018														
WREG13	001A														
WREG14	001C														
WREG15	001E														
SPLIM	0020														
PCL	002E														
PCH	0030	—	—	—	—	—	—	—	—	—	—	—	—	—	—
TBLPAG	0032	—	—	—	—	—	—	—	—	—	—	—	—	—	—
PSV/PAG	0034	—	—	—	—	—	—	—	—	—	—	—	—	—	—
RCOUNT	0036														
SR	0042	—	—	—	—	—	—	—	—	—	—	—	—	—	—
CORCON	0044	—	—	—	—	—	—	—	—	—	—	—	—	—	—
DISICNT	0052	—	—	—	—	—	—	—	—	—	—	—	—	—	—

**Legend:** — = unimplemented, read as '0'. Reset values are shown in hexadecimal.

**TABLE 4-4: ICN REGISTER MAP**

File Name	Addr	Bit 15	Bit 14	Bit 13	Bit 12	Bit 11	Bit 10	Bit 9	Bit 8	Bit 7	Bit 6	Bit 5	Bit 4	Bit 3	Bit 2
CNPD1	0054	CN15PDE	CN14PDE	CN13PDE	CN12PDE	CN11PDE	CN10PDE	CN9PDE	CN8PDE	CN7PDE	CN6PDE	CN5PDE	CN4PDE	CN3PDE	CN2PDE
CNPD2	0056	CN31PDE	CN30PDE	CN29PDE	CN28PDE	CN27PDE	CN26PDE	CN25PDE	CN24PDE	CN23PDE	CN22PDE	CN21PDE <sup>(1)</sup>	CN20PDE <sup>(1)</sup>	CN19PDE <sup>(1)</sup>	CN18PDE <sup>(1)</sup>
CNPD3	0058	CN47PDE <sup>(1)</sup>	CN46PDE <sup>(2)</sup>	CN45PDE <sup>(1)</sup>	CN44PDE <sup>(1)</sup>	CN43PDE <sup>(1)</sup>	CN42PDE <sup>(1)</sup>	CN41PDE <sup>(1)</sup>	CN40PDE <sup>(2)</sup>	CN39PDE <sup>(2)</sup>	CN38PDE <sup>(2)</sup>	CN37PDE <sup>(2)</sup>	CN36PDE <sup>(2)</sup>	CN35PDE <sup>(2)</sup>	CN34PDE <sup>(2)</sup>
CNPD4	005A	CN63PDE	CN62PDE	CN61PDE	CN60PDE	CN59PDE	CN58PDE	CN57PDE <sup>(1)</sup>	CN56PDE	CN55PDE	CN54PDE	CN53PDE	CN52PDE	CN51PDE	CN50PDE
CNPD5	005C	CN79PDE <sup>(2)</sup>	CN78PDE <sup>(1)</sup>	CN77PDE <sup>(1)</sup>	CN76PDE <sup>(2)</sup>	CN75PDE <sup>(2)</sup>	CN74PDE <sup>(1)</sup>	CN73PDE <sup>(1)</sup>	CN72PDE	CN71PDE	CN70PDE	CN69PDE	CN68PDE	CN67PDE <sup>(1)</sup>	CN66PDE <sup>(1)</sup>
CNPD6	005E	—	—	—	—	—	—	—	—	—	—	—	CN84PDE	CN83PDE	CN82PDE
CNE1	0060	CN15IE	CN14IE	CN13IE	CN12IE	CN11IE	CN10IE	CN9IE	CN8IE	CN7IE	CN6IE	CN5IE	CN4IE	CN3IE	CN2IE
CNE2	0062	CN31IE	CN30IE	CN29IE	CN28IE	CN27IE	CN26IE	CN25IE	CN24IE	CN23IE	CN22IE	CN21IE <sup>(1)</sup>	CN20IE <sup>(1)</sup>	CN19IE <sup>(1)</sup>	CN18IE <sup>(1)</sup>
CNE3	0064	CN47IE <sup>(1)</sup>	CN46IE <sup>(2)</sup>	CN45IE <sup>(1)</sup>	CN44IE <sup>(1)</sup>	CN43IE <sup>(1)</sup>	CN42IE <sup>(1)</sup>	CN41IE <sup>(1)</sup>	CN40IE <sup>(2)</sup>	CN39IE <sup>(2)</sup>	CN38IE <sup>(2)</sup>	CN37IE <sup>(2)</sup>	CN36IE <sup>(2)</sup>	CN35IE <sup>(2)</sup>	CN34IE <sup>(2)</sup>
CNE4	0066	CN63IE	CN62IE	CN61IE	CN60IE	CN59IE	CN58IE	CN57IE <sup>(1)</sup>	CN56IE	CN55IE	CN54IE	CN53IE	CN52IE	CN51IE	CN50IE
CNE5	0068	CN79IE <sup>(2)</sup>	CN78IE <sup>(1)</sup>	CN77IE <sup>(1)</sup>	CN76IE <sup>(2)</sup>	CN75IE <sup>(2)</sup>	CN74IE <sup>(1)</sup>	CN73IE <sup>(1)</sup>	CN72IE	CN71IE	CN70IE	CN69IE	CN68IE	CN67IE <sup>(1)</sup>	CN66IE <sup>(1)</sup>
CNE6	006A	—	—	—	—	—	—	—	—	—	—	—	CN84IE	CN83IE	CN82IE <sup>(1)</sup>
CNPL1	006C	CN15PUE	CN14PUE	CN13PUE	CN12PUE	CN11PUE	CN10PUE	CN9PUE	CN8PUE	CN7PUE	CN6PUE	CN5PUE	CN4PUE	CN3PUE	CN2PUE
CNPL2	006E	CN31PUE	CN30PUE	CN29PUE	CN28PUE	CN27PUE	CN26PUE	CN25PUE	CN24PUE	CN23PUE	CN22PUE	CN21PUE <sup>(1)</sup>	CN20PUE <sup>(1)</sup>	CN19PUE <sup>(1)</sup>	CN18PUE <sup>(1)</sup>
CNPL3	0070	CN47PUE <sup>(1)</sup>	CN46PUE <sup>(2)</sup>	CN45PUE <sup>(1)</sup>	CN44PUE <sup>(1)</sup>	CN43PUE <sup>(1)</sup>	CN42PUE <sup>(1)</sup>	CN41PUE <sup>(1)</sup>	CN40PUE <sup>(2)</sup>	CN39PUE <sup>(2)</sup>	CN38PUE <sup>(2)</sup>	CN37PUE <sup>(2)</sup>	CN36PUE <sup>(2)</sup>	CN35PUE <sup>(2)</sup>	CN34PUE <sup>(2)</sup>
CNPL4	0072	CN63PUE	CN62PUE	CN61PUE	CN60PUE	CN59PUE	CN58PUE	CN57PUE <sup>(1)</sup>	CN56PUE	CN55PUE	CN54PUE	CN53PUE	CN52PUE	CN51PUE	CN50PUE
CNPL5	0074	CN79PUE <sup>(2)</sup>	CN78PUE <sup>(1)</sup>	CN77PUE <sup>(1)</sup>	CN76PUE <sup>(2)</sup>	CN75PUE <sup>(2)</sup>	CN74PUE <sup>(1)</sup>	CN73PUE <sup>(1)</sup>	CN72PUE	CN71PUE	CN70PUE	CN69PUE	CN68PUE	CN67PUE <sup>(1)</sup>	CN66PUE <sup>(1)</sup>
CNPL6	0076	—	—	—	—	—	—	—	—	—	—	—	CN84PUE	CN83PUE	CN82PUE

**Legend:** — = unimplemented, read as '0'. Reset values are shown in hexadecimal.

**Note 1:** Unimplemented in 64-pin devices; read as '0'.

**2:** Unimplemented in 64-pin and 80-pin devices; read as '0'.

**TABLE 4-5: INTERRUPT CONTROLLER REGISTER MAP**

File Name	Addr	Bit 15	Bit 14	Bit 13	Bit 12	Bit 11	Bit 10	Bit 9	Bit 8	Bit 7	Bit 6	Bit 5	Bit 4	Bit 3	Bit 2	
INTCON1	0080	NSTD/S	—	—	—	—	—	—	—	—	—	—	MATHERR	ADDRERR	STKERR	
INTCON2	0082	ALTVT	DISI	—	—	—	—	—	—	—	—	—	INT4EP	INT3EP	INT2EP	
IFS0	0084	—	—	AD1F	U1TXIF	U1RXIF	SP11F	SPF1F	T3IF	T2IF	OC2IF	IC2IF	—	T1F	OC1F	
IFS1	0086	U2TXIF	U2RXIF	INT2IF	T5F	T4F	OC4F	OC3F	—	IC8F	IC7F	—	INT1F	CMIF	CMIF	
IFS2	0088	—	—	PMP1F	OC8IF	OC7F	OC6IF	OC5F	IC6F	IC5F	IC4F	IC3F	—	—	—	
IFS3	008A	—	RTCF	—	—	—	—	—	—	INT4IF	INT3IF	INT3IF	—	—	M12C2IF	
IFS4	008C	—	—	CTMUJF	—	—	—	—	LVDIF	—	—	—	—	—	U2ERIP	
IFS5	008E	—	—	IC9F	OC9F	SPI3F	SPF3F	U4TXIF	U4RXIF	—	—	—	—	CRCIF	U3ERIP	
IEC0	0094	—	—	AD1E	U1TXIE	U1RXIE	SP11E	SPF1E	T3IE	T2IE	OC2IE	IC2IE	—	T1IE	OC1IE	
IEC1	0096	U2TXIE	U2RXIE	INT2IE	T5IE	T4IE	OC4IE	OC3IE	—	IC8IE	IC7IE	—	INT1IE	CMIE	CMIE	
IEC2	0098	—	—	PMP1E	OC8IE	OC7IE	OC6IE	OC5IE	IC6IE	IC5IE	IC4IE	IC3IE	—	—	—	
IEC3	009A	—	RTCIE	—	—	—	—	—	—	INT4IE	INT3IE	INT3IE	—	—	M12C2IE	
IEC4	009C	—	—	CTMUJIE	—	—	—	—	LVDIE	—	—	—	—	—	U2ERIE	
IEC5	009E	—	—	IC9IE	OC9IE	SPI3IE	SPF3IE	U4TXIE	U4RXIE	—	—	—	—	CRCIE	U3RXIE	
IPC0	00A4	—	T1IP2	T1IP1	T1IP0	—	OC1IP2	OC1IP1	OC1IP0	—	IC1IP2	IC1IP1	IC1IP0	—	INT0IP	
IPC1	00A6	—	T2IP2	T2IP1	T2IP0	—	OC2IP2	OC2IP1	OC2IP0	—	IC2IP2	IC2IP1	IC2IP0	—	INT0IP	
IPC2	00A8	—	U1RXIP2	U1RXIP1	U1RXIP0	—	SP11IP2	SP11IP1	SP11IP0	—	SPF1IP2	SPF1IP1	SPF1IP0	—	T3IP2	
IPC3	00AA	—	—	—	—	—	—	—	—	—	AD1IP2	AD1IP1	AD1IP0	—	U1TXIP	
IPC4	00AC	—	—	CNIP1	CNIP0	—	CMIP2	CMIP1	CMIP0	—	M12C1IP2	M12C1IP1	M12C1IP0	—	SI2C1IP	
IPC5	00AE	—	IC8IP2	IC8IP1	IC8IP0	—	IC7IP2	IC7IP1	IC7IP0	—	—	—	—	—	INT1IP2	
IPC6	00B0	—	T4IP2	T4IP1	T4IP0	—	OC4IP2	OC4IP1	OC4IP0	—	OC3IP2	OC3IP1	OC3IP0	—	—	
IPC7	00B2	—	U2TXIP2	U2TXIP1	U2TXIP0	—	U2RXIP2	U2RXIP1	U2RXIP0	—	INT2IP2	INT2IP1	INT2IP0	—	T5IP2	
IPC8	00B4	—	—	—	—	—	—	—	—	—	SP2IP2	SP2IP1	SP2IP0	—	SPF2IP	
IPC9	00B6	—	IC5IP2	IC5IP1	IC5IP0	—	IC4IP2	IC4IP1	IC4IP0	—	IC3IP2	IC3IP1	IC3IP0	—	—	
IPC10	00B8	—	OC7IP2	OC7IP1	OC7IP0	—	OC6IP2	OC6IP1	OC6IP0	—	OC5IP2	OC5IP1	OC5IP0	—	IC6IP2	
IPC11	00BA	—	—	—	—	—	—	—	—	—	PMP1P2	PMP1P1	PMP1P0	—	OC8IP2	
IPC12	00BC	—	—	—	—	—	M12C2IP2	M12C2IP1	M12C2IP0	—	SI2C2IP2	SI2C2IP1	SI2C2IP0	—	—	
IPC13	00BE	—	—	—	—	—	INT4IP2	INT4IP1	INT4IP0	—	INT3IP2	INT3IP1	INT3IP0	—	—	
IPC15	00C2	—	—	—	—	—	RTCIP2	RTCIP1	RTCIP0	—	—	—	—	—	—	
IPC16	00C4	—	CRCIP2	CRCIP1	CRCIP0	—	U2ERIP2	U2ERIP1	U2ERIP0	—	U1ERIP2	U1ERIP1	U1ERIP0	—	—	
IPC18	00C8	—	—	—	—	—	—	—	—	—	CTMUJIP2	CTMUJIP1	CTMUJIP0	—	LVDIP2	
IPC19	00CA	—	—	—	—	—	—	—	—	—	—	—	—	—	—	
IPC20	00CC	—	U3TXIP2	U3TXIP1	U3TXIP0	—	U3RXIP2	U3RXIP1	U3RXIP0	—	U3ERIP2	U3ERIP1	U3ERIP0	—	—	
IPC21	00CE	—	U4ERIP2	U4ERIP1	U4ERIP0	—	—	—	—	—	M12C3IP2	M12C3IP1	M12C3IP0	—	SI2C3IP	
IPC22	00D0	—	SPI3IP2	SPI3IP1	SPI3IP0	—	SPF3IP2	SPF3IP1	SPF3IP0	—	U4TXIP2	U4TXIP1	U4TXIP0	—	U4RXIP	
IPC23	00D2	—	—	—	—	—	—	—	—	—	IC9IP2	IC9IP1	IC9IP0	—	OC9IP	
INTTREG	00E0	CPUIRQ	—	VHOLD	—	—	ILR[3:0]	—	—	—	—	—	—	—	—	VECNUM[6:0]

**Legend:** — = unimplemented, read as '0'. Reset values are shown in hexadecimal.

**TABLE 4-6: TIMER REGISTER MAP**

File Name	Addr	Bit 15	Bit 14	Bit 13	Bit 12	Bit 11	Bit 10	Bit 9	Bit 8	Bit 7	Bit 6	Bit 5	Bit 4	Bit 3	Bit 2
TMR1	0100	Timer1 Register													
PR1	0102	Timer1 Period Register													
T1CON	0104	TON	—	TSIDL	—	—	—	—	—	—	TGATE	TCKPS[1:0]	—	—	TSYN
TMR2	0106	Timer2 Register													
TMR3HLD	0108	Timer3 Holding Register (for 32-bit timer operations only)													
TMR3	010A	Timer3 Register													
PR2	010C	Timer2 Period Register													
PR3	010E	Timer3 Period Register													
T2CON	0110	TON	—	TSIDL	—	—	—	—	—	—	TGATE	TCKPS[1:0]	T32	—	—
T3CON	0112	TON	—	TSIDL	—	—	—	—	—	—	TGATE	TCKPS[1:0]	—	—	—
TMR4	0114	Timer4 Register													
TMR5HLD	0116	Timer5 Holding Register (for 32-bit operations only)													
TMR5	0118	Timer5 Register													
PR4	011A	Timer4 Period Register													
PR5	011C	Timer5 Period Register													
T4CON	011E	TON	—	TSIDL	—	—	—	—	—	—	TGATE	TCKPS[1:0]	T32	—	—
T5CON	0120	TON	—	TSIDL	—	—	—	—	—	—	TGATE	TCKPS[1:0]	—	—	—

**Legend:** — = unimplemented, read as '0'. Reset values are shown in hexadecimal.

**TABLE 4-7: INPUT CAPTURE REGISTER MAP**

File Name	Addr	Bit 15	Bit 14	Bit 13	Bit 12	Bit 11	Bit 10	Bit 9	Bit 8	Bit 7	Bit 6	Bit 5	Bit 4	Bit 3	Bit 2
IC1CON1	0140	—	—	ICSIDL	—	CTSEL[2:0]	—	—	—	—	—	—	ICOV	ICBNE	SYNCSEL[4]
IC1CON2	0142	—	—	—	—	—	—	—	IC32	ICTRIG	TRIGSTAT	—	—	—	—
IC1BUF	0144	Input Capture 1 Buffer Register													
IC1TMR	0146	Timer Value 1 Register													
IC2CON1	0148	—	—	ICSIDL	—	CTSEL[2:0]	—	—	—	—	—	—	ICOV	ICBNE	SYNCSEL[4]
IC2CON2	014A	—	—	—	—	—	—	—	IC32	ICTRIG	TRIGSTAT	—	—	—	—
IC2BUF	014C	Input Capture 2 Buffer Register													
IC2TMR	014E	Timer Value 2 Register													
IC3CON1	0150	—	—	ICSIDL	—	CTSEL[2:0]	—	—	—	—	—	—	ICOV	ICBNE	SYNCSEL[4]
IC3CON2	0152	—	—	—	—	—	—	—	IC32	ICTRIG	TRIGSTAT	—	—	—	—
IC3BUF	0154	Input Capture 3 Buffer Register													
IC3TMR	0156	Timer Value 3 Register													
IC4CON1	0158	—	—	ICSIDL	—	CTSEL[2:0]	—	—	—	—	—	—	ICOV	ICBNE	SYNCSEL[4]
IC4CON2	015A	—	—	—	—	—	—	—	IC32	ICTRIG	TRIGSTAT	—	—	—	—
IC4BUF	015C	Input Capture 4 Buffer Register													
IC4TMR	015E	Timer Value 4 Register													
IC5CON1	0160	—	—	ICSIDL	—	CTSEL[2:0]	—	—	—	—	—	—	ICOV	ICBNE	SYNCSEL[4]
IC5CON2	0162	—	—	—	—	—	—	—	IC32	ICTRIG	TRIGSTAT	—	—	—	—
IC5BUF	0164	Input Capture 5 Buffer Register													
IC5TMR	0166	Timer Value 5 Register													
IC6CON1	0168	—	—	ICSIDL	—	CTSEL[2:0]	—	—	—	—	—	—	ICOV	ICBNE	SYNCSEL[4]
IC6CON2	016A	—	—	—	—	—	—	—	IC32	ICTRIG	TRIGSTAT	—	—	—	—
IC6BUF	016C	Input Capture 6 Buffer Register													
IC6TMR	016E	Timer Value 6 Register													
IC7CON1	0170	—	—	ICSIDL	—	CTSEL[2:0]	—	—	—	—	—	—	ICOV	ICBNE	SYNCSEL[4]
IC7CON2	0172	—	—	—	—	—	—	—	IC32	ICTRIG	TRIGSTAT	—	—	—	—
IC7BUF	0174	Input Capture 7 Buffer Register													
IC7TMR	0176	Timer Value 7 Register													
IC8CON1	0178	—	—	ICSIDL	—	CTSEL[2:0]	—	—	—	—	—	—	ICOV	ICBNE	SYNCSEL[4]
IC8CON2	017A	—	—	—	—	—	—	—	IC32	ICTRIG	TRIGSTAT	—	—	—	—
IC8BUF	017C	Input Capture 8 Buffer Register													
IC8TMR	017E	Timer Value 8 Register													
IC9CON1	0180	—	—	ICSIDL	—	CTSEL[2:0]	—	—	—	—	—	—	ICOV	ICBNE	SYNCSEL[4]
IC9CON2	0182	—	—	—	—	—	—	—	IC32	ICTRIG	TRIGSTAT	—	—	—	—
IC9BUF	0184	Input Capture 9 Buffer Register													
IC9TMR	0186	Timer Value 9 Register													

**Legend:** — = unimplemented, read as '0'. Reset values are shown in hexadecimal.

**TABLE 4-8: OUTPUT COMPARE REGISTER MAP**

File Name	Addr	Bit 15	Bit 14	Bit 13	Bit 12	Bit 11	Bit 10	Bit 9	Bit 8	Bit 7	Bit 6	Bit 5	Bit 4	Bit 3	Bit 2
OC1CON1	0190	—	—	OCSIDL	OCINVL	OCTSEL[2:0]	—	—	—	ENFLT0	—	—	OCFLT0	TRIGMODE	—
OC1CON2	0192	FLTMD	FLTOUT	FLTTRIEN	OCINV	—	—	OC32	OC32	OC2TRIG	TRIGSTAT	OC2TRIS	—	—	SYNCSEL[1:0]
OC1RS	0194	Output Compare 1 Secondary Register													
OC1R	0196	Output Compare 1 Register													
OC1TMR	0198	Timer Value 1 Register													
OC2CON1	019A	—	—	OCSIDL	OCINVL	OCTSEL[2:0]	—	—	—	ENFLT0	—	—	OCFLT0	TRIGMODE	—
OC2CON2	019C	FLTMD	FLTOUT	FLTTRIEN	OCINV	—	—	OC32	OC32	OC2TRIG	TRIGSTAT	OC2TRIS	—	—	SYNCSEL[1:0]
OC2RS	019E	Output Compare 2 Secondary Register													
OC2R	01A0	Output Compare 2 Register													
OC2TMR	01A2	Timer Value 2 Register													
OC3CON1	01A4	—	—	OCSIDL	OCINVL	OCTSEL[2:0]	—	—	—	ENFLT0	—	—	OCFLT0	TRIGMODE	—
OC3CON2	01A6	FLTMD	FLTOUT	FLTTRIEN	OCINV	—	—	OC32	OC32	OC3TRIG	TRIGSTAT	OC3TRIS	—	—	SYNCSEL[1:0]
OC3RS	01A8	Output Compare 3 Secondary Register													
OC3R	01AA	Output Compare 3 Register													
OC3TMR	01AC	Timer Value 3 Register													
OC4CON1	01AE	—	—	OCSIDL	OCINVL	OCTSEL[2:0]	—	—	—	ENFLT0	—	—	OCFLT0	TRIGMODE	—
OC4CON2	01B0	FLTMD	FLTOUT	FLTTRIEN	OCINV	—	—	OC32	OC32	OC4TRIG	TRIGSTAT	OC4TRIS	—	—	SYNCSEL[1:0]
OC4RS	01B2	Output Compare 4 Secondary Register													
OC4R	01B4	Output Compare 4 Register													
OC4TMR	01B6	Timer Value 4 Register													
OC5CON1	01B8	—	—	OCSIDL	OCINVL	OCTSEL[2:0]	—	—	—	ENFLT0	—	—	OCFLT0	TRIGMODE	—
OC5CON2	01BA	FLTMD	FLTOUT	FLTTRIEN	OCINV	—	—	OC32	OC32	OC5TRIG	TRIGSTAT	OC5TRIS	—	—	SYNCSEL[1:0]
OC5RS	01BC	Output Compare 5 Secondary Register													
OC5R	01BE	Output Compare 5 Register													
OC5TMR	01C0	Timer Value 5 Register													
OC6CON1	01C2	—	—	OCSIDL	OCINVL	OCTSEL[2:0]	—	—	—	ENFLT0	—	—	OCFLT0	TRIGMODE	—
OC6CON2	01C4	FLTMD	FLTOUT	FLTTRIEN	OCINV	—	—	OC32	OC32	OC6TRIG	TRIGSTAT	OC6TRIS	—	—	SYNCSEL[1:0]
OC6RS	01C6	Output Compare 6 Secondary Register													
OC6R	01C8	Output Compare 6 Register													
OC6TMR	01CA	Timer Value 6 Register													
OC7CON1	01CC	—	—	OCSIDL	OCINVL	OCTSEL[2:0]	—	—	—	ENFLT0	—	—	OCFLT0	TRIGMODE	—
OC7CON2	01CE	FLTMD	FLTOUT	FLTTRIEN	OCINV	—	—	OC32	OC32	OC7TRIG	TRIGSTAT	OC7TRIS	—	—	SYNCSEL[1:0]
OC7RS	01D0	Output Compare 7 Secondary Register													
OC7R	01D2	Output Compare 7 Register													
OC7TMR	01D4	Timer Value 7 Register													

**Legend:** — = unimplemented, read as '0'. Reset values are shown in hexadecimal.

**TABLE 4-8: OUTPUT COMPARE REGISTER MAP (CONTINUED)**

File Name	Addr	Bit 15	Bit 14	Bit 13	Bit 12	Bit 11	Bit 10	Bit 9	Bit 8	Bit 7	Bit 6	Bit 5	Bit 4	Bit 3	Bit 2
OC8CON1	01D6	—	—	—	—	—	—	—	—	ENFLT0	—	—	OCFLT0	TRIGMODE	SYNCSEL[1]
OC8CON2	01D8	FLTMD	FLTOUT	FLTTRIEN	OCINV	OC{TSEL}[2:0]	—	—	OC32	OC{TRIG	TRIGSTAT	OC{TRIS	—	—	—
OC8RS	01DA	—	—	—	—	—	—	—	OC32	OC{TRIG	TRIGSTAT	OC{TRIS	—	—	—
OC8R	01DC	—	—	—	—	—	—	—	—	—	—	—	—	—	—
OC8TMR	01DE	—	—	—	—	—	—	—	—	ENFLT0	—	—	OCFLT0	TRIGMODE	SYNCSEL[1]
OC9CON1	01E0	—	—	OC{SIDL	—	OC{TSEL}[2:0]	—	—	OC32	OC{TRIG	TRIGSTAT	OC{TRIS	—	—	—
OC9CON2	01E2	FLTMD	FLTOUT	FLTTRIEN	OCINV	—	—	—	OC32	OC{TRIG	TRIGSTAT	OC{TRIS	—	—	—
OC9RS	01E4	—	—	—	—	—	—	—	—	—	—	—	—	—	—
OC9R	01E6	—	—	—	—	—	—	—	—	—	—	—	—	—	—
OC9TMR	01E8	—	—	—	—	—	—	—	—	—	—	—	—	—	—

Legend: — = unimplemented, read as '0'. Reset values are shown in hexadecimal.

**TABLE 4-9: I<sup>2</sup>C REGISTER MAP**

File Name	Addr	Bit 15	Bit 14	Bit 13	Bit 12	Bit 11	Bit 10	Bit 9	Bit 8	Bit 7	Bit 6	Bit 5	Bit 4	Bit 3	Bit 2
I2C1RCV	0200	—	—	—	—	—	—	—	—	—	—	—	—	—	—
I2C1TRN	0202	—	—	—	—	—	—	—	—	—	—	—	—	—	—
I2C1BRG	0204	—	—	—	—	—	—	—	—	—	—	—	—	—	—
I2C1CON	0206	I2CEN	—	I2CSIDL	SCLREL	IPMIEN	A10M	DISSLW	SMEN	GCEN	STREN	ACKDT	ACKEN	ROEN	PEN
I2C1STAT	0208	ACKSTAT	TRSTAT	—	—	—	BCL	GCSTAT	ADD10	IWCOL	I2COV	D/Ā	P	S	R/W
I2C1ADD	020A	—	—	—	—	—	—	—	—	—	—	—	—	—	—
I2C1MSK	020C	—	—	—	—	—	—	—	—	—	—	—	—	—	—
I2C2RCV	0210	—	—	—	—	—	—	—	—	—	—	—	—	—	—
I2C2TRN	0212	—	—	—	—	—	—	—	—	—	—	—	—	—	—
I2C2BRG	0214	—	—	—	—	—	—	—	—	—	—	—	—	—	—
I2C2CON	0216	I2CEN	—	I2CSIDL	SCLREL	IPMIEN	A10M	DISSLW	SMEN	GCEN	STREN	ACKDT	ACKEN	ROEN	PEN
I2C2STAT	0218	ACKSTAT	TRSTAT	—	—	—	BCL	GCSTAT	ADD10	IWCOL	I2COV	D/Ā	P	S	R/W
I2C2ADD	021A	—	—	—	—	—	—	—	—	—	—	—	—	—	—
I2C2MSK	021C	—	—	—	—	—	—	—	—	—	—	—	—	—	—
I2C3RCV	0270	—	—	—	—	—	—	—	—	—	—	—	—	—	—
I2C3TRN	0272	—	—	—	—	—	—	—	—	—	—	—	—	—	—
I2C3BRG	0274	—	—	—	—	—	—	—	—	—	—	—	—	—	—
I2C3CON	0276	I2CEN	—	I2CSIDL	SCLREL	IPMIEN	A10M	DISSLW	SMEN	GCEN	STREN	ACKDT	ACKEN	ROEN	PEN
I2C3STAT	0278	ACKSTAT	TRSTAT	—	—	—	BCL	GCSTAT	ADD10	IWCOL	I2COV	D/Ā	P	S	R/W
I2C3ADD	027A	—	—	—	—	—	—	—	—	—	—	—	—	—	—
I2C3MSK	027C	—	—	—	—	—	—	—	—	—	—	—	—	—	—

Legend: — = unimplemented, read as '0'. Reset values are shown in hexadecimal.

**TABLE 4-10: UART REGISTER MAP**

File Name	Addr	Bit 15	Bit 14	Bit 13	Bit 12	Bit 11	Bit 10	Bit 9	Bit 8	Bit 7	Bit 6	Bit 5	Bit 4	Bit 3	Bit 2
U1MODE	0220	UARTEN	—	USIDL	IREN	RTSMD	—	UEN[1:0]	WAKE	LPBACK	ABAUD	RXINV	BRGH	—	—
U1STA	0222	UTXISEL1	UTXINV	UTXISEL0	—	UTXBRK	UTXEN	UTXBF	TRMT	URXISEL[1:0]	ADDEN	RIDLE	PERR	FERR	—
U1TXREG	0224	—	—	—	—	—	—	—	—	—	—	—	—	—	—
U1RXREG	0226	—	—	—	—	—	—	—	—	—	—	—	—	—	—
U1BRG	0228	Baud Rate Generator Prescaler													
U2MODE	0230	UARTEN	—	USIDL	IREN	RTSMD	—	UEN[1:0]	WAKE	LPBACK	ABAUD	RXINV	BRGH	—	—
U2STA	0232	UTXISEL1	UTXINV	UTXISEL0	—	UTXBRK	UTXEN	UTXBF	TRMT	URXISEL[1:0]	ADDEN	RIDLE	PERR	FERR	—
U2TXREG	0234	—	—	—	—	—	—	—	—	—	—	—	—	—	—
U2RXREG	0236	—	—	—	—	—	—	—	—	—	—	—	—	—	—
U2BRG	0238	Baud Rate Generator Prescaler													
U3MODE	0250	UARTEN	—	USIDL	IREN	RTSMD	—	UEN[1:0]	WAKE	LPBACK	ABAUD	RXINV	BRGH	—	—
U3STA	0252	UTXISEL1	UTXINV	UTXISEL0	—	UTXBRK	UTXEN	UTXBF	TRMT	URXISEL[1:0]	ADDEN	RIDLE	PERR	FERR	—
U3TXREG	0254	—	—	—	—	—	—	—	—	—	—	—	—	—	—
U3RXREG	0256	—	—	—	—	—	—	—	—	—	—	—	—	—	—
U3BRG	0258	Baud Rate Generator Prescaler													
U4MODE	0280	UARTEN	—	USIDL	IREN	RTSMD	—	UEN[1:0]	WAKE	LPBACK	ABAUD	RXINV	BRGH	—	—
U4STA	0282	UTXISEL1	UTXINV	UTXISEL0	—	UTXBRK	UTXEN	UTXBF	TRMT	URXISEL[1:0]	ADDEN	RIDLE	PERR	FERR	—
U4TXREG	0284	—	—	—	—	—	—	—	—	—	—	—	—	—	—
U4RXREG	0286	—	—	—	—	—	—	—	—	—	—	—	—	—	—
U4BRG	0288	Baud Rate Generator Prescaler													

Legend: — = unimplemented, read as '0'. Reset values are shown in hexadecimal.

**TABLE 4-11: SPI REGISTER MAP**

File Name	Addr	Bit 15	Bit 14	Bit 13	Bit 12	Bit 11	Bit 10	Bit 9	Bit 8	Bit 7	Bit 6	Bit 5	Bit 4	Bit 3	Bit 2
SPI1STAT	0240	SPIEN	—	SPSIDL	—	—	—	SPIBEC[2:0]	SRMPT	SPROV	SRXMPT	SISEL[2:0]	—	—	—
SPI1CON1	0242	—	—	—	DISSCK	DISSDO	MODE16	SMP	CKE	SSEN	CKP	MSTEN	SPRE[2:0]	—	—
SPI1CON2	0244	FRMEN	SPIFSD	SPIFPOL	—	—	—	—	—	—	—	—	—	—	—
SPI1BUF	0248	Transmit and Receive Buffer													
SPI2STAT	0260	SPIEN	—	SPSIDL	—	—	—	SPIBEC[2:0]	SRMPT	SPROV	SRXMPT	SISEL[2:0]	—	—	—
SPI2CON1	0262	—	—	—	DISSCK	DISSDO	MODE16	SMP	CKE	SSEN	CKP	MSTEN	SPRE[2:0]	—	—
SPI2CON2	0264	FRMEN	SPIFSD	SPIFPOL	—	—	—	—	—	—	—	—	—	—	—
SPI2BUF	0268	Transmit and Receive Buffer													
SPI3STAT	0280	SPIEN	—	SPSIDL	—	—	—	SPIBEC[2:0]	SRMPT	SPROV	SRXMPT	SISEL[2:0]	—	—	—
SPI3CON1	0282	—	—	—	DISSCK	DISSDO	MODE16	SMP	CKE	SSEN	CKP	MSTEN	SPRE[2:0]	—	—
SPI3CON2	0284	FRMEN	SPIFSD	SPIFPOL	—	—	—	—	—	—	—	—	—	—	—
SPI3BUF	0288	Transmit and Receive Buffer													

Legend: — = unimplemented, read as '0'. Reset values are shown in hexadecimal.

**TABLE 4-12: PORTA REGISTER MAP<sup>(1)</sup>**

File Name	Addr	Bit 15	Bit 14	Bit 13	Bit 12	Bit 11	Bit 10	Bit 9	Bit 8	Bit 7 <sup>(2)</sup>	Bit 6 <sup>(2)</sup>	Bit 5 <sup>(2)</sup>	Bit 4 <sup>(2)</sup>	Bit 3 <sup>(2)</sup>	Bit 2 <sup>(2)</sup>
TRISA	02C0	TRISA[15:14]	—	—	—	—	TRISA[10:9]	—	—	—	—	—	TRISA[7:0]	—	—
PORTA	02C2	RA[15:14]	—	—	—	—	RA[10:9]	—	—	—	—	—	RA[7:0]	—	—
LATA	02C4	LATA[15:14]	—	—	—	—	LATA[10:9]	—	—	—	—	—	LATA[7:0]	—	—
ODCA	02C6	ODA[15:14]	—	—	—	—	ODA[10:9]	—	—	—	—	—	ODA[7:0]	—	—

**Legend:** — = unimplemented, read as '0'. Reset values are shown in hexadecimal. Reset values shown are for 100-pin devices.

**Note 1:** PORTA and all associated bits are unimplemented on 64-pin devices and read as '0'. Bits are available on 80-pin and 100-pin devices only, unless otherwise noted.

**2:** Bits are implemented on 100-pin devices only; otherwise, read as '0'.

**TABLE 4-13: PORTB REGISTER MAP**

File Name	Addr	Bit 15	Bit 14	Bit 13	Bit 12	Bit 11	Bit 10	Bit 9	Bit 8	Bit 7	Bit 6	Bit 5	Bit 4	Bit 3	Bit 2
TRISB	02C8	TRISB[15:0]													
PORTB	02CA	RB[15:0]													
LATB	02CC	LATB[15:0]													
ODCB	02CE	ODB[15:0]													

**Legend:** Reset values are shown in hexadecimal.

**TABLE 4-14: PORTC REGISTER MAP**

File Name	Addr	Bit 15	Bit 14	Bit 13	Bit 12	Bit 11	Bit 10	Bit 9	Bit 8	Bit 7	Bit 6	Bit 5	Bit 4 <sup>(1)</sup>	Bit 3 <sup>(2)</sup>	Bit 2 <sup>(1)</sup>
TRISC	02D0	TRISC[15:12]													
PORTC	02D2	RC15 <sup>(3,4)</sup>	RC14	RC13	RC12 <sup>(3)</sup>	—	—	—	—	—	—	—	—	TRISC[4:1]	—
LATC	02D4	LATC[15:12]													
ODCC	02D6	ODC[15:12]													

**Legend:** — = unimplemented, read as '0'. Reset values are shown in hexadecimal. Reset values shown are for 100-pin devices.

**Note 1:** Bits are unimplemented in 64-pin and 80-pin devices; read as '0'.

**2:** Bits are unimplemented in 64-pin devices; read as '0'.

**3:** RC12 and RC15 are only available when the Primary Oscillator is disabled or when EC mode is selected (POSCMD[1:0] Configuration bits = 11 or 00); otherwise, read as '0'.

**4:** RC15 is only available when POSCMD[1:0] Configuration bits = 11 or 00 and the OSCIOFN Configuration bit = 1.

**TABLE 4-15: PORTD REGISTER MAP**

File Name	Addr	Bit 15 <sup>(1)</sup>	Bit 14 <sup>(1)</sup>	Bit 13 <sup>(1)</sup>	Bit 12 <sup>(1)</sup>	Bit 11	Bit 10	Bit 9	Bit 8	Bit 7	Bit 6	Bit 5	Bit 4	Bit 3	Bit 2
TRISD	02D8	TRISD[15:0]													
PORTD	02DA	RD[15:0]													
LATD	02DC	LATD[15:0]													
ODCD	02DE	ODD[15:0]													

**Legend:** — = unimplemented, read as '0'. Reset values are shown in hexadecimal. Reset values shown are for 100-pin devices.

**Note 1:** Bits are unimplemented on 64-pin devices; read as '0'.

**TABLE 4-16: PORTE REGISTER MAP**

File Name	Addr	Bit 15	Bit 14	Bit 13	Bit 12	Bit 11	Bit 10	Bit 9 <sup>(1)</sup>	Bit 8 <sup>(1)</sup>	Bit 7	Bit 6	Bit 5	Bit 4	Bit 3	Bit 2
TRISE	02E0	—	—	—	—	—	—	TRISE[9:0]							
PORTE	02E2	—	—	—	—	—	—	RE[9:0]							
LATE	02E4	—	—	—	—	—	—	LATE[9:0]							
ODCE	02E6	—	—	—	—	—	—	ODE[9:0]							

**Legend:** — = unimplemented, read as '0'. Reset values are shown in hexadecimal. Reset values shown are for 100-pin devices.

**Note 1:** Bits are unimplemented in 64-pin devices; read as '0'.

**TABLE 4-17: PORTF REGISTER MAP**

File Name	Addr	Bit 15	Bit 14	Bit 13 <sup>(1)</sup>	Bit 12 <sup>(1)</sup>	Bit 11	Bit 10	Bit 9	Bit 8 <sup>(2)</sup>	Bit 7 <sup>(2)</sup>	Bit 6	Bit 5	Bit 4	Bit 3	Bit 2
TRISF	02E8	—	—	TRISF[13:12]	—	—	—	—	TRISF[8:0]						
PORTF	02EA	—	—	RF[13:12]	—	—	—	—	RF[8:0]						
LATF	02EC	—	—	LATF[13:12]	—	—	—	—	LATF[8:0]						
ODCF	02EE	—	—	ODF[13:12]	—	—	—	—	ODF[8:0]						

**Legend:** — = unimplemented, read as '0'. Reset values are shown in hexadecimal. Reset values shown are for 100-pin devices.

**Note 1:** Bits are unimplemented in 64-pin and 80-pin devices; read as '0'.

**2:** Bits are unimplemented in 64-pin devices; read as '0'.

**TABLE 4-18: PORTG REGISTER MAP**

File Name	Addr	Bit 15 <sup>(1)</sup>	Bit 14 <sup>(1)</sup>	Bit 13 <sup>(1)</sup>	Bit 12 <sup>(1)</sup>	Bit 11	Bit 10	Bit 9	Bit 8	Bit 7	Bit 6	Bit 5	Bit 4	Bit 3	Bit 2
TRISG	02F0	—	TRISG[15:12]	—	—	—	—	—	TRISG[9:6]						
PORTG	02F2	—	RG[15:12]	—	—	—	—	—	RG[9:6]						
LATG	02F4	—	LATG[15:12]	—	—	—	—	—	LATG[9:6]						
ODCG	02F6	—	ODG[15:12]	—	—	—	—	—	ODG[9:6]						

**Legend:** — = unimplemented, read as '0'. Reset values are shown in hexadecimal. Reset values shown are for 100-pin devices.

**Note 1:** Bits are unimplemented in 64-pin and 80-pin devices; read as '0'.

**2:** Bits are unimplemented in 64-pin devices; read as '0'.

**TABLE 4-19: PAD CONFIGURATION REGISTER MAP**

File Name	Addr	Bit 15	Bit 14	Bit 13	Bit 12	Bit 11	Bit 10	Bit 9	Bit 8	Bit 7	Bit 6	Bit 5	Bit 4	Bit 3	Bit 2
PADCFG1	02FC	—	—	—	—	—	—	—	—	—	—	—	—	—	—

**Legend:** — = unimplemented, read as '0'. Reset values are shown in hexadecimal.

**TABLE 4-20: ADC REGISTER MAP**

File Name	Addr	Bit 15	Bit 14	Bit 13	Bit 12	Bit 11	Bit 10	Bit 9	Bit 8	Bit 7	Bit 6	Bit 5	Bit 4	Bit 3	Bit
ADC1BUF0	0300														
ADC1BUF1	0302														
ADC1BUF2	0304														
ADC1BUF3	0306														
ADC1BUF4	0308														
ADC1BUF5	030A														
ADC1BUF6	030C														
ADC1BUF7	030E														
ADC1BUF8	0310														
ADC1BUF9	0312														
ADC1BUFA	0314														
ADC1BUFB	0316														
ADC1BUFC	0318														
ADC1BUFD	031A														
ADC1BUFE	031C														
ADC1BUFF	031E														
AD1CON1	0320	ADON	—	ADSIDL	—	—	—	FORM[1:0]	—	SSRC[2:0]	—	—	—	—	ASA
AD1CON2	0322	VCFG[2:0]			r	—	CSCNA	—	—	BUFS	—	—	SMP[3:0]	—	—
AD1CON3	0324	ADRC	r				SAMC[4:0]						ADCS[7:0]		
AD1CHS	0328	CH0NB	—	—	—	—	CH0SB[4:0]			CH0NA	—	—	—	—	CH0SA
AD1PCFGL	032C									PCFG[15:0]					
AD1PCFGH	032A	—	—	—	—	—	—	—	—	—	—	—	—	—	—
AD1CSSL	0330									CSSL[15:0]					

Legend: — = unimplemented, read as '0', r = reserved, maintain as '0'. Reset values are shown in hexadecimal.

**TABLE 4-21: CTMU REGISTER MAP**

File Name	Addr	Bit 15	Bit 14	Bit 13	Bit 12	Bit 11	Bit 10	Bit 9	Bit 8	Bit 7	Bit 6	Bit 5	Bit 4	Bit 3	Bit 2
CTMUCON	033C	CTMUEN	—	CTMUSIDL	TGEN	EDGEN	EDGSEQEN	IDISSEN	CTTRIG	EDG2POL	EDG2SEL[1:0]	EDG1POL	EDG1SEL[1:0]	—	—
CTMUICON	033E							ITRIM[5:0]		IRNG[1:0]	—	—	—	—	—

Legend: — = unimplemented, read as '0'. Reset values are shown in hexadecimal.

**TABLE 4-22: PARALLEL MASTER/SLAVE PORT REGISTER MAP**

File Name	Addr	Bit 15	Bit 14	Bit 13	Bit 12	Bit 11	Bit 10	Bit 9	Bit 8	Bit 7	Bit 6	Bit 5	Bit 4	Bit 3	Bit 2
PMCON	0600	PMPEN	—	PSIDL	ADRMUX[1:0]	PTBEEN	PTWREN	PTRDEN	MODE[1:0]	WAITB[1:0]	ALP	CS2P	CS1P	WAITM[3:0]	BEP
PMMODE	0602	BUSY	IRQM[1:0]	INCM[1:0]	—	—	—	—	—	—	—	—	—	—	—
PMADDR	0604	CS[2:1]	—	—	—	—	—	—	—	—	—	—	—	—	—
PMDDOUT1	—	—	—	—	—	—	—	—	—	—	—	—	—	—	—
PMDDOUT2	0606	—	—	—	—	—	—	—	—	—	—	—	—	—	—
PMDDIN1	0608	—	—	—	—	—	—	—	—	—	—	—	—	—	—
PMDDIN2	060A	—	—	—	—	—	—	—	—	—	—	—	—	—	—
PMAEN	060C	—	—	—	—	—	—	—	—	—	—	—	—	—	—
PMSTAT	060E	IBF	IBOV	—	—	IB3F	IB2F	IB1F	IB0F	OBE	OBUF	—	—	OB3E	OB2E

Legend: — = unimplemented, read as '0'. Reset values are shown in hexadecimal.

**TABLE 4-23: REAL-TIME CLOCK AND CALENDAR REGISTER MAP**

File Name	Addr	Bit 15	Bit 14	Bit 13	Bit 12	Bit 11	Bit 10	Bit 9	Bit 8	Bit 7	Bit 6	Bit 5	Bit 4	Bit 3	Bit 2
ALRMVAL	0620	—	—	—	—	—	—	—	—	—	—	—	—	—	—
ALCFGPRPT	0622	ALRMEN	CHIME	AMASK[3:0]	—	—	—	—	—	—	—	—	—	—	—
RTCVVAL	0624	—	—	—	—	—	—	—	—	—	—	—	—	—	—
RTCFGCAL	0626	RTCEN	—	RTCWREN	RTCSYNC	HALFSEC	RTCOE	RTCPTR[1:0]	—	—	—	—	—	—	—

Legend: — = unimplemented, read as '0'. Reset values are shown in hexadecimal.

**TABLE 4-24: COMPARATORS REGISTER MAP**

File Name	Addr	Bit 15	Bit 14	Bit 13	Bit 12	Bit 11	Bit 10	Bit 9	Bit 8	Bit 7	Bit 6	Bit 5	Bit 4	Bit 3	Bit 2
CMSTAT	0630	CMIDL	—	—	—	—	C3EVT	C2EVT	C1EVT	—	—	—	—	—	C30U
CVRRCON	0632	—	—	—	—	—	—	—	—	CVREN	CVROE	CVRR	CVRSS	—	—
CM1CON	0634	CEN	COE	CPOL	—	—	—	CEVT	COUT	—	—	—	—	—	—
CM2CON	0636	CEN	COE	CPOL	—	—	—	CEVT	COUT	—	—	—	—	—	—
CM3CON	0638	CEN	COE	CPOL	—	—	—	CEVT	COUT	—	—	—	—	—	—

Legend: — = unimplemented, read as '0'. Reset values are shown in hexadecimal.

**TABLE 4-25: CRC REGISTER MAP**

File Name	Addr	Bit 15	Bit 14	Bit 13	Bit 12	Bit 11	Bit 10	Bit 9	Bit 8	Bit 7	Bit 6	Bit 5	Bit 4	Bit 3	Bit 2
CRCCON	0640	—	—	CSIDL	—	—	VWORD[4:0]	—	—	—	—	—	—	—	—
CRCXOR	0642	—	—	—	—	—	—	—	—	—	—	—	—	—	—
CRCDAT	0644	—	—	—	—	—	—	—	—	—	—	—	—	—	—
CRCWDAT	0646	—	—	—	—	—	—	—	—	—	—	—	—	—	—

Legend: — = unimplemented, read as '0'. Reset values are shown in hexadecimal.

**TABLE 4-26: PERIPHERAL PIN SELECT REGISTER MAP**

File Name	Addr	Bit 15	Bit 14	Bit 13	Bit 12	Bit 11	Bit 10	Bit 9	Bit 8	Bit 7	Bit 6	Bit 5	Bit 4	Bit 3	Bit 2
RPINR0	0680	—	—	INT1R5	INT1R4	INT1R3	INT1R2	INT1R1	INT1R0	—	—	—	—	—	—
RPINR1	0682	—	—	INT3R5	INT3R4	INT3R3	INT3R2	INT3R1	INT3R0	—	—	INT2R5	INT2R4	INT2R3	INT2R2
RPINR2	0684	—	—	—	—	—	—	—	—	—	—	INT4R5	INT4R4	INT4R3	INT4R2
RPINR3	0686	—	—	T3CKR5	T3CKR4	T3CKR3	T3CKR2	T3CKR1	T3CKR0	—	—	T2CKR5	T2CKR4	T2CKR3	T2CKR2
RPINR4	0688	—	—	T5CKR5	T5CKR4	T5CKR3	T5CKR2	T5CKR1	T5CKR0	—	—	T4CKR5	T4CKR4	T4CKR3	T4CKR2
RPINR7	068E	—	—	IC2R5	IC2R4	IC2R3	IC2R2	IC2R1	IC2R0	—	—	IC1R5	IC1R4	IC1R3	IC1R2
RPINR8	0690	—	—	IC4R5	IC4R4	IC4R3	IC4R2	IC4R1	IC4R0	—	—	IC3R5	IC3R4	IC3R3	IC3R2
RPINR9	0692	—	—	IC6R5	IC6R4	IC6R3	IC6R2	IC6R1	IC6R0	—	—	IC5R5	IC5R4	IC5R3	IC5R2
RPINR10	0694	—	—	IC8R5	IC8R4	IC8R3	IC8R2	IC8R1	IC8R0	—	—	IC7R5	IC7R4	IC7R3	IC7R2
RPINR11	0696	—	—	OCFBR5	OCFBR4	OCFBR3	OCFBR2	OCFBR1	OCFBR0	—	—	OCFAR5	OCFAR4	OCFAR3	OCFAR2
RPINR15	069E	—	—	IC9R5	IC9R4	IC9R3	IC9R2	IC9R1	IC9R0	—	—	—	—	—	—
RPINR17	06A2	—	—	U3RXR5	U3RXR4	U3RXR3	U3RXR2	U3RXR1	U3RXR0	—	—	—	—	—	—
RPINR18	06A4	—	—	U1CTS5	U1CTS4	U1CTS3	U1CTS2	U1CTS1	U1CTS0	—	—	U1RXR5	U1RXR4	U1RXR3	U1RXR2
RPINR19	06A6	—	—	U2CTS5	U2CTS4	U2CTS3	U2CTS2	U2CTS1	U2CTS0	—	—	U2RXR5	U2RXR4	U2RXR3	U2RXR2
RPINR20	06A8	—	—	SCK1R5	SCK1R4	SCK1R3	SCK1R2	SCK1R1	SCK1R0	—	—	SD1R5	SD1R4	SD1R3	SD1R2
RPINR21	06AA	—	—	U3CTS5	U3CTS4	U3CTS3	U3CTS2	U3CTS1	U3CTS0	—	—	SS1R5	SS1R4	SS1R3	SS1R2
RPINR22	06AC	—	—	SCK2R5	SCK2R4	SCK2R3	SCK2R2	SCK2R1	SCK2R0	—	—	SD2R5	SD2R4	SD2R3	SD2R2
RPINR23	06AE	—	—	—	—	—	—	—	—	—	—	SS2R5	SS2R4	SS2R3	SS2R2
RPINR27	06B6	—	—	U4CTS5	U4CTS4	U4CTS3	U4CTS2	U4CTS1	U4CTS0	—	—	U4RXR5	U4RXR4	U4RXR3	U4RXR2
RPINR28	06B8	—	—	SCK3R5	SCK3R4	SCK3R3	SCK3R2	SCK3R1	SCK3R0	—	—	SD3R5	SD3R4	SD3R3	SD3R2
RPINR29	06BA	—	—	—	—	—	—	—	—	—	—	SS3R5	SS3R4	SS3R3	SS3R2
RPOR0	06C0	—	—	RP1R5	RP1R4	RP1R3	RP1R2	RP1R1	RP1R0	—	—	RP0R5	RP0R4	RP0R3	RP0R2
RPOR1	06C2	—	—	RP3R5	RP3R4	RP3R3	RP3R2	RP3R1	RP3R0	—	—	RP2R5	RP2R4	RP2R3	RP2R2
RPOR2	06C4	—	—	RP5R5 <sup>(1)</sup>	RP5R4 <sup>(1)</sup>	RP5R3 <sup>(1)</sup>	RP5R2 <sup>(1)</sup>	RP5R1 <sup>(1)</sup>	RP5R0 <sup>(1)</sup>	—	—	RP4R5	RP4R4	RP4R3	RP4R2
RPOR3	06C6	—	—	RP7R5	RP7R4	RP7R3	RP7R2	RP7R1	RP7R0	—	—	RP6R5	RP6R4	RP6R3	RP6R2
RPOR4	06C8	—	—	RP9R5	RP9R4	RP9R3	RP9R2	RP9R1	RP9R0	—	—	RP8R5	RP8R4	RP8R3	RP8R2
RPOR5	06CA	—	—	RP11R5	RP11R4	RP11R3	RP11R2	RP11R1	RP11R0	—	—	RP10R5	RP10R4	RP10R3	RP10R2
RPOR6	06CC	—	—	RP13R5	RP13R4	RP13R3	RP13R2	RP13R1	RP13R0	—	—	RP12R5	RP12R4	RP12R3	RP12R2
RPOR7	06CE	—	—	RP15R5 <sup>(1)</sup>	RP15R4 <sup>(1)</sup>	RP15R3 <sup>(1)</sup>	RP15R2 <sup>(1)</sup>	RP15R1 <sup>(1)</sup>	RP15R0 <sup>(1)</sup>	—	—	RP14R5	RP14R4	RP14R3	RP14R2
RPOR8	06D0	—	—	RP17R5	RP17R4	RP17R3	RP17R2	RP17R1	RP17R0	—	—	RP16R5	RP16R4	RP16R3	RP16R2
RPOR9	06D2	—	—	RP19R5	RP19R4	RP19R3	RP19R2	RP19R1	RP19R0	—	—	RP18R5	RP18R4	RP18R3	RP18R2
RPOR10	06D4	—	—	RP21R5	RP21R4	RP21R3	RP21R2	RP21R1	RP21R0	—	—	RP20R5	RP20R4	RP20R3	RP20R2
RPOR11	06D6	—	—	RP23R5	RP23R4	RP23R3	RP23R2	RP23R1	RP23R0	—	—	RP22R5	RP22R4	RP22R3	RP22R2
RPOR12	06D8	—	—	RP25R5	RP25R4	RP25R3	RP25R2	RP25R1	RP25R0	—	—	RP24R5	RP24R4	RP24R3	RP24R2
RPOR13	06DA	—	—	RP27R5	RP27R4	RP27R3	RP27R2	RP27R1	RP27R0	—	—	RP26R5	RP26R4	RP26R3	RP26R2
RPOR14	06DC	—	—	RP29R5	RP29R4	RP29R3	RP29R2	RP29R1	RP29R0	—	—	RP28R5	RP28R4	RP28R3	RP28R2
RPOR15	06DE	—	—	RP31R5 <sup>(2)</sup>	RP31R4 <sup>(2)</sup>	RP31R3 <sup>(2)</sup>	RP31R2 <sup>(2)</sup>	RP31R1 <sup>(2)</sup>	RP31R0 <sup>(2)</sup>	—	—	RP30R5	RP30R4	RP30R3	RP30R2
ALTRP	06E2	—	—	—	—	—	—	—	—	—	—	—	—	—	—

**Legend:** — = unimplemented, read as '0'. Reset values are shown in hexadecimal.

**Note 1:** Bits are unimplemented in 64-pin devices; read as '0'.

**2:** Bits are unimplemented in 64-pin and 80-pin devices; read as '0'.

**TABLE 4-27: SYSTEM REGISTER MAP**

File Name	Addr	Bit 15	Bit 14	Bit 13	Bit 12	Bit 11	Bit 10	Bit 9	Bit 8	Bit 7	Bit 6	Bit 5	Bit 4	Bit 3	Bit 2
RCON	0740	TRAPR	IOPUWR	—	—	—	—	CM	PMSLP	EXTR	SWR	SWDTEN	WDTO	SLEEP	IDLE
OSCCON	0742	—	—	COSC[2:0]	—	—	—	NOSC[2:0]	—	CLKLOCK	IOLCK	LOCK	—	CF	POSC
CLKDIV	0744	ROI	—	DOZE[2:0]	DOZEN	—	—	RCDIV[2:0]	—	—	—	—	—	—	—
OSCTUN	0748	—	—	—	—	—	—	—	—	—	—	—	—	—	TUN[5:0]
REFOCON	074E	ROEN	—	ROSSLP	ROSEL	—	RODIV[3:0]	—	—	—	—	—	—	—	—

**Legend:** — = unimplemented, read as '0'. Reset values are shown in hexadecimal.

**Note 1:** The Reset value of the RCON register is dependent on the type of Reset event. See [Section 6.0 “Resets”](#) for more information.

**Note 2:** The Reset value of the OSCCON register is dependent on both the type of Reset event and the device configuration. See [Section 8.0 “Oscillator Configuration”](#) for

**TABLE 4-28: NVM REGISTER MAP**

File Name	Addr	Bit 15	Bit 14	Bit 13	Bit 12	Bit 11	Bit 10	Bit 9	Bit 8	Bit 7	Bit 6	Bit 5	Bit 4	Bit 3	Bit 2
NVMCON	0760	WR	WREN	WRERR	—	—	—	—	—	—	ERASE	—	—	—	NVM
NVMKEY	0766	—	—	—	—	—	—	—	—	—	—	—	—	—	NVMKEY[7:0]

**Legend:** — = unimplemented, read as '0'. Reset values are shown in hexadecimal.

**Note 1:** Reset value shown is for POR only. Value on other Reset states is dependent on the state of memory write or erase operations at the time of Reset.

**TABLE 4-29: PMD REGISTER MAP**

File Name	Addr	Bit 15	Bit 14	Bit 13	Bit 12	Bit 11	Bit 10	Bit 9	Bit 8	Bit 7	Bit 6	Bit 5	Bit 4	Bit 3	Bit 2
PMD1	0770	T5MD	T4MD	T3MD	T2MD	T1MD	—	—	—	I2C1MD	U2MD	U1MD	SPI2MD	SPI1MD	—
PMD2	0772	IC8MD	IC7MD	IC6MD	IC5MD	IC4MD	IC3MD	IC2MD	IC1MD	OC8MD	OC7MD	OC6MD	OC5MD	OC4MD	OC3MD
PMD3	0774	—	—	—	—	—	CMPMD	RTCCMD	PMPMD	CRCMD	—	—	—	U3MD	I2C3MD
PMD4	0776	—	—	—	—	—	—	—	—	—	—	U4MD	—	REFOMD	CTMUMD
PMD5	0778	—	—	—	—	—	—	—	IC9MD	—	—	—	—	—	—
PMD6	077A	—	—	—	—	—	—	—	—	—	—	—	—	—	—

**Legend:** — = unimplemented, read as '0'. Reset values are shown in hexadecimal.

# PIC24FJ256GA110 FAMILY

## 4.2.5 SOFTWARE STACK

In addition to its use as a Working register, the W15 register in PIC24F devices is also used as a Software Stack Pointer. The pointer always points to the first available free word and grows from lower to higher addresses. It decrements for stack pops and post-increments for stack pushes, as shown in Figure 4-4. Note that for a PC push during any CALL instruction, the MSB of the PC is zero-extended before the push, ensuring that the MSB is always clear.

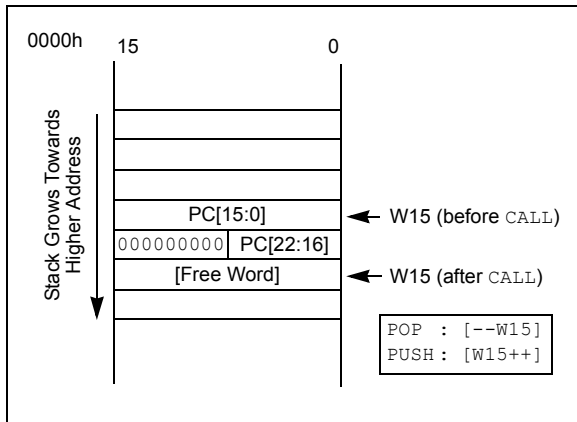
**Note:** A PC push during exception processing will concatenate the SRL register to the MSB of the PC prior to the push.

The Stack Pointer Limit Value (SPLIM) register, associated with the Stack Pointer, sets an upper address boundary for the stack. SPLIM is uninitialized at Reset. As is the case for the Stack Pointer, SPLIM[0] is forced to '0' because all stack operations must be word-aligned. Whenever an EA is generated using W15 as a source or destination pointer, the resulting address is compared with the value in SPLIM. If the contents of the Stack Pointer (W15) and the SPLIM register are equal, and a push operation is performed, a stack error trap will not occur. The stack error trap will occur on a subsequent push operation. Thus, for example, if it is desirable to cause a stack error trap when the stack grows beyond address 2000h in RAM, initialize the SPLIM with the value, 1FFEh.

Similarly, a Stack Pointer underflow (stack error) trap is generated when the Stack Pointer address is found to be less than 0800h. This prevents the stack from interfering with the Special Function Register (SFR) space.

A write to the SPLIM register should not be immediately followed by an indirect read operation using W15.

**FIGURE 4-4: CALL STACK FRAME**



## 4.3 Interfacing Program and Data Memory Spaces

The PIC24F architecture uses a 24-bit wide program space and a 16-bit wide Data Space. The architecture is also a modified Harvard scheme, meaning that data can also be present in the program space. To use these data successfully, they must be accessed in a way that preserves the alignment of information in both spaces.

Aside from normal execution, the PIC24F architecture provides two methods by which program space can be accessed during operation:

- Using table instructions to access individual bytes or words anywhere in the program space
- Remapping a portion of the program space into the Data Space (Program Space Visibility)

Table instructions allow an application to read or write to small areas of the program memory. This makes the method ideal for accessing data tables that need to be updated from time to time. It also allows access to all bytes of the program word. The remapping method allows an application to access a large block of data on a read-only basis, which is ideal for look-ups from a large table of static data; it can only access the least significant word of the program word.

### 4.3.1 ADDRESSING PROGRAM SPACE

Since the address ranges for the data and program spaces are 16 and 24 bits, respectively, a method is needed to create a 23-bit or 24-bit program address from 16-bit data registers. The solution depends on the interface method to be used.

For table operations, the 8-bit Table Memory Page Address (TBLPAG) register is used to define a 32K word region within the program space. This is concatenated with a 16-bit EA to arrive at a full 24-bit program space address. In this format, the Most Significant bit of TBLPAG is used to determine if the operation occurs in the user memory (TBLPAG[7] = 0) or the configuration memory (TBLPAG[7] = 1).

For remapping operations, the 8-bit Program Space Visibility Page Address (PSVPAG) register is used to define a 16K word page in the program space. When the Most Significant bit of the EA is '1', PSVPAG is concatenated with the lower 15 bits of the EA to form a 23-bit program space address. Unlike table operations, this limits remapping operations strictly to the user memory area.

Table 4-30 and Figure 4-5 show how the program EA is created for table operations and remapping accesses from the data EA. Here, P[23:0] refers to a program space word, whereas D[15:0] refers to a Data Space word.

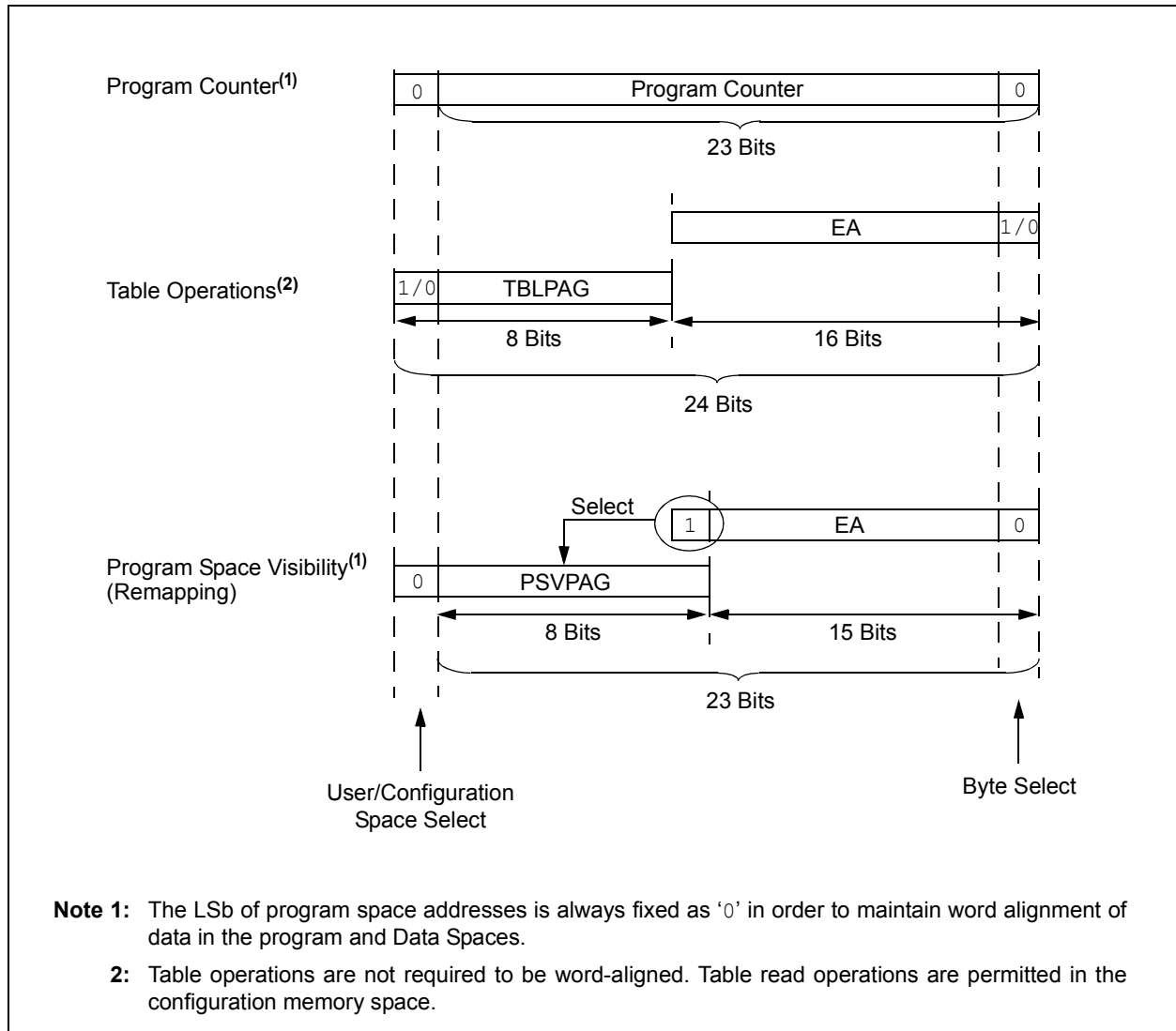
# PIC24FJ256GA110 FAMILY

**TABLE 4-30: PROGRAM SPACE ADDRESS CONSTRUCTION**

Access Type	Access Space	Program Space Address				
		[23]	[22:16]	[15]	[14:1]	[0]
Instruction Access (Code Execution)	User	0	PC[22:1]			0
		0xx xxxx xxxx xxxx xxxx xxx0				
TBLRD/TBLWT (Byte/Word Read/Write)	User	TBLPAG[7:0]		Data EA[15:0]		
		0xxx xxxx xxxx xxxx xxxx xxxx				
	Configuration	TBLPAG[7:0]		Data EA[15:0]		
		1xxx xxxx xxxx xxxx xxxx xxxx				
Program Space Visibility (Block Remap/Read)	User	0	PSVPAG[7:0]		Data EA[14:0] <sup>(1)</sup>	
		0	xxxx xxxx		xxx xxxx xxxx xxxx	

**Note 1:** Data EA[15] is always '1' in this case, but is not used in calculating the program space address. Bit 15 of the address is PSVPAG[0].

**FIGURE 4-5: DATA ACCESS FROM PROGRAM SPACE ADDRESS GENERATION**



# PIC24FJ256GA110 FAMILY

## 4.3.2 DATA ACCESS FROM PROGRAM MEMORY USING TABLE INSTRUCTIONS

The `TBLRDL` and `TBLWTL` instructions offer a direct method of reading or writing the lower word of any address within the program space without going through Data Space. The `TBLRDH` and `TBLWTH` instructions are the only method to read or write the upper eight bits of a program space word as data.

The PC is incremented by two for each successive 24-bit program word. This allows program memory addresses to directly map to Data Space addresses. Program memory can thus be regarded as two, 16-bit word-wide address spaces, residing side by side, each with the same address range. `TBLRDL` and `TBLWTL` access the space which contains the least significant data word, and `TBLRDH` and `TBLWTH` access the space which contains the upper data byte.

Two table instructions are provided to move byte or word-sized (16-bit) data to and from program space. Both function as either byte or word operations.

1. `TBLRDL` (Table Read Low): In Word mode, it maps the lower word of the program space location ( $P[15:0]$ ) to a data address ( $D[15:0]$ ). In Byte mode, either the upper or lower byte of the lower program word is mapped to the lower byte of a data address. The upper byte is selected when the byte select is '1'; the lower byte is selected when it is '0'.

2. `TBLRDH` (Table Read High): In Word mode, it maps the entire upper word of a program address ( $P[23:16]$ ) to a data address. Note that  $D[15:8]$ , the 'phantom' byte, will always be '0'.

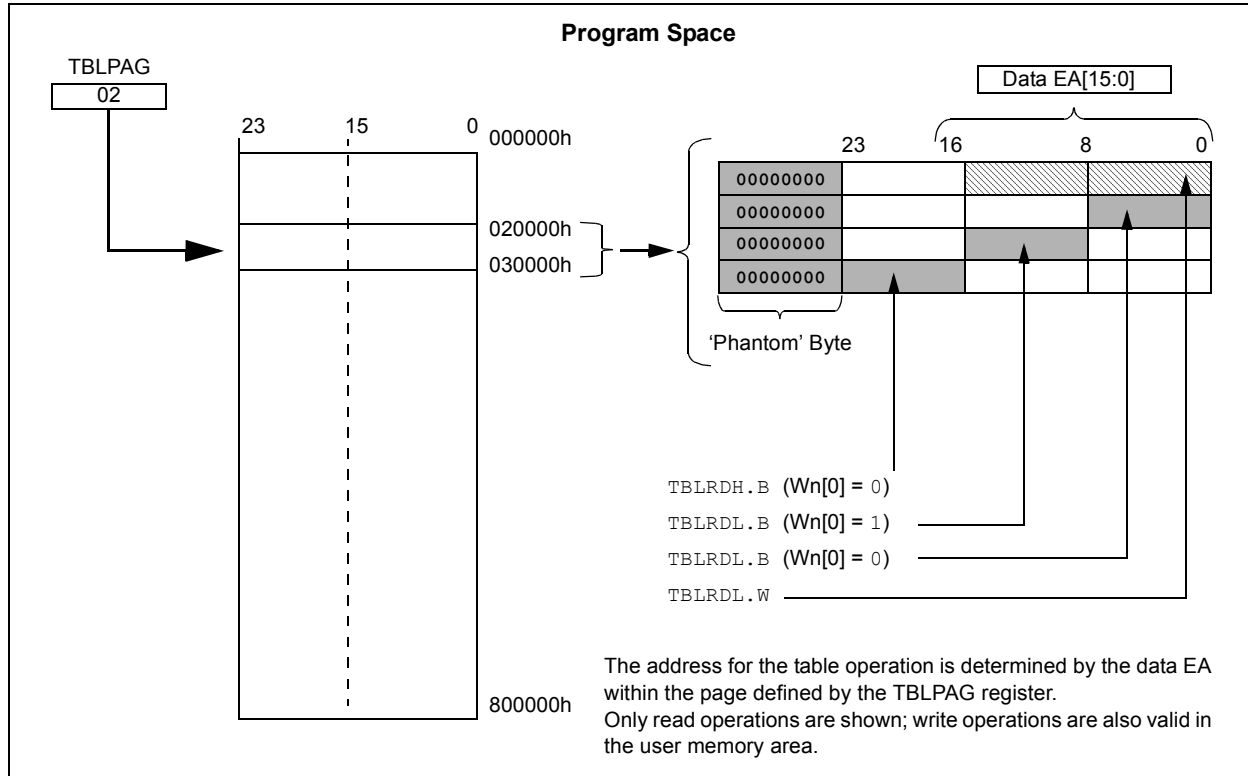
In Byte mode, it maps the upper or lower byte of the program word to  $D[7:0]$  of the data address, as above. Note that the data will always be '0' when the upper 'phantom' byte is selected (byte select = 1).

In a similar fashion, two table instructions, `TBLWTH` and `TBLWTL`, are used to write individual bytes or words to a program space address. The details of their operation are explained in **Section 5.0 "Flash Program Memory"**.

For all table operations, the area of program memory space to be accessed is determined by the Table Memory Page Address (TBLPAG) register. TBLPAG covers the entire program memory space of the device, including user and configuration spaces. When  $TBLPAG[7] = 0$ , the table page is located in the user memory space. When  $TBLPAG[7] = 1$ , the page is located in configuration space.

**Note:** Only table read operations will execute in the configuration memory space, and only then, in implemented areas, such as the Device ID. Table write operations are not allowed.

**FIGURE 4-6: ACCESSING PROGRAM MEMORY WITH TABLE INSTRUCTIONS**



# PIC24FJ256GA110 FAMILY

## 4.3.3 READING DATA FROM PROGRAM MEMORY USING PROGRAM SPACE VISIBILITY

The upper 32 Kbytes of Data Space may optionally be mapped into any 16K word page of the program space. This provides transparent access of stored constant data from the Data Space without the need to use special instructions (i.e., `TBLRDL/H`).

Program space access through the Data Space occurs if the Most Significant bit (MSb) of the Data Space EA is '1' and Program Space Visibility is enabled by setting the PSV bit in the CPU Control (`CORCON[2]`) register. The location of the program memory space to be mapped into the Data Space is determined by the Program Space Visibility Page Address (`PSVPAG`) register. This 8-bit register defines any one of 256 possible pages of 16K words in program space. In effect, `PSVPAG` functions as the upper 8 bits of the program memory address, with the 15 bits of the EA functioning as the lower bits. Note that by incrementing the PC by two for each program memory word, the lower 15 bits of Data Space addresses directly map to the lower 15 bits in the corresponding program space addresses.

Data reads to this area add an additional cycle to the instruction being executed, since two program memory fetches are required.

Although each Data Space address, 8000h and higher, maps directly into a corresponding program memory address (see Figure 4-7), only the lower 16 bits of the

24-bit program word are used to contain the data. The upper eight bits of any program space locations used as data should be programmed with '1111 1111' or '0000 0000' to force a `NOE`. This prevents possible issues should the area of code ever be accidentally executed.

**Note:** PSV access is temporarily disabled during table reads/writes.

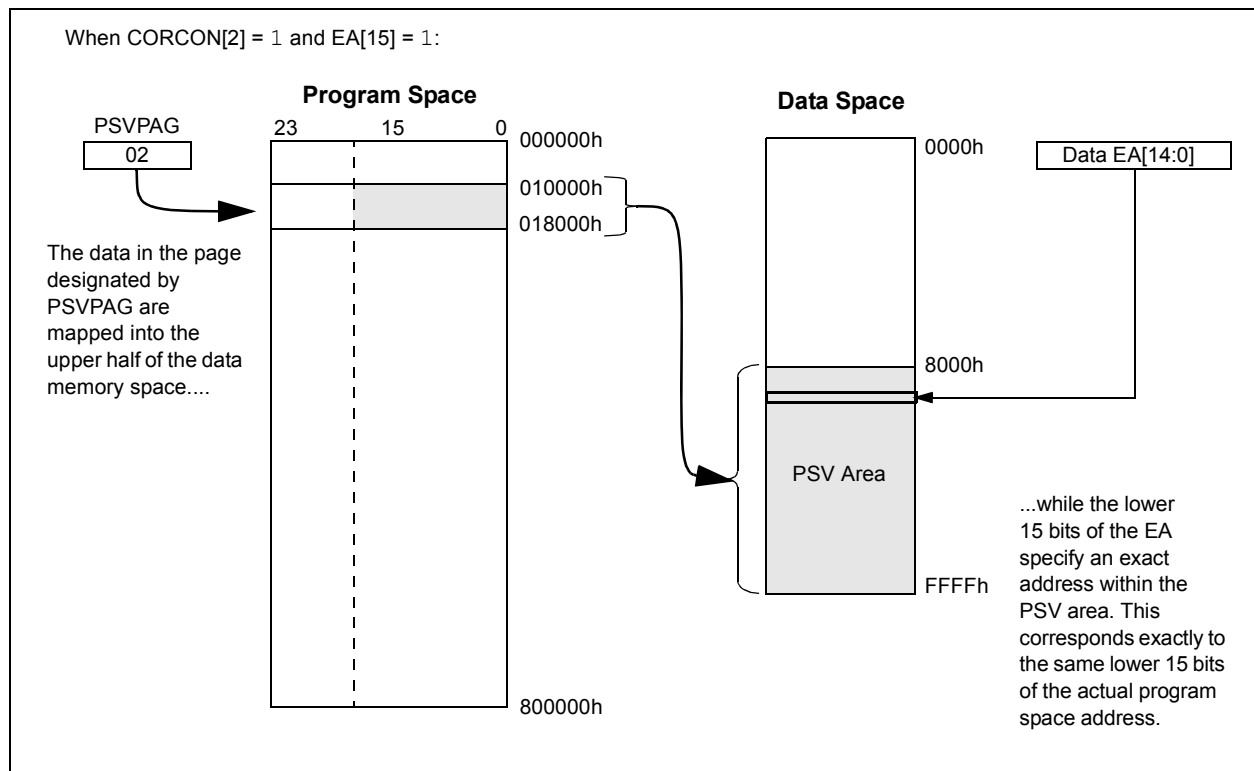
For operations that use PSV and are executed outside a `REPEAT` loop, the `MOV` and `MOV.D` instructions will require one instruction cycle in addition to the specified execution time. All other instructions will require two instruction cycles in addition to the specified execution time.

For operations that use PSV which are executed inside a `REPEAT` loop, there will be some instances that require two instruction cycles in addition to the specified execution time of the instruction:

- Execution in the first iteration
- Execution in the last iteration
- Execution prior to exiting the loop due to an interrupt
- Execution upon re-entering the loop after an interrupt is serviced

Any other iteration of the `REPEAT` loop will allow the instruction accessing data, using PSV, to execute in a single cycle.

**FIGURE 4-7: PROGRAM SPACE VISIBILITY OPERATION**



# PIC24FJ256GA110 FAMILY

---

NOTES:

# PIC24FJ256GA110 FAMILY

## 5.0 FLASH PROGRAM MEMORY

**Note:** This data sheet summarizes the features of this group of PIC24F devices. It is not intended to be a comprehensive reference source. For more information, refer to “PIC24F Flash Program Memory” ([www.microchip.com/DS30009715](http://www.microchip.com/DS30009715)) in the “dsPIC33/PIC24 Family Reference Manual”. The information in this data sheet supersedes the information in the FRM.

The PIC24FJ256GA110 family of devices contains internal Flash program memory for storing and executing application code. The memory is readable, writable and erasable when operating with VDD over 2.35V. If the regulator is disabled, the VDDCORE voltage must be over 2.25V.

Flash memory can be programmed in three ways:

- In-Circuit Serial Programming™ (ICSP™)
- Run-Time Self-Programming (RTSP)
- Enhanced In-Circuit Serial Programming (Enhanced ICSP)

ICSP allows a PIC24FJ256GA110 family device to be serially programmed while in the end application circuit. This is simply done with two lines for the programming clock and programming data (which are named PGECx and PGEDx, respectively), and three other lines for power (VDD), ground (VSS) and Master Clear (MCLR). This allows customers to manufacture boards with unprogrammed devices and then program the micro-

controller just before shipping the product. This also allows the most recent firmware or a custom firmware to be programmed.

RTSP is accomplished using TBLRD (table read) and TBLWT (table write) instructions. With RTSP, the user may write program memory data in blocks of 64 instructions (192 bytes) at a time and erase program memory in blocks of 512 instructions (1536 bytes) at a time.

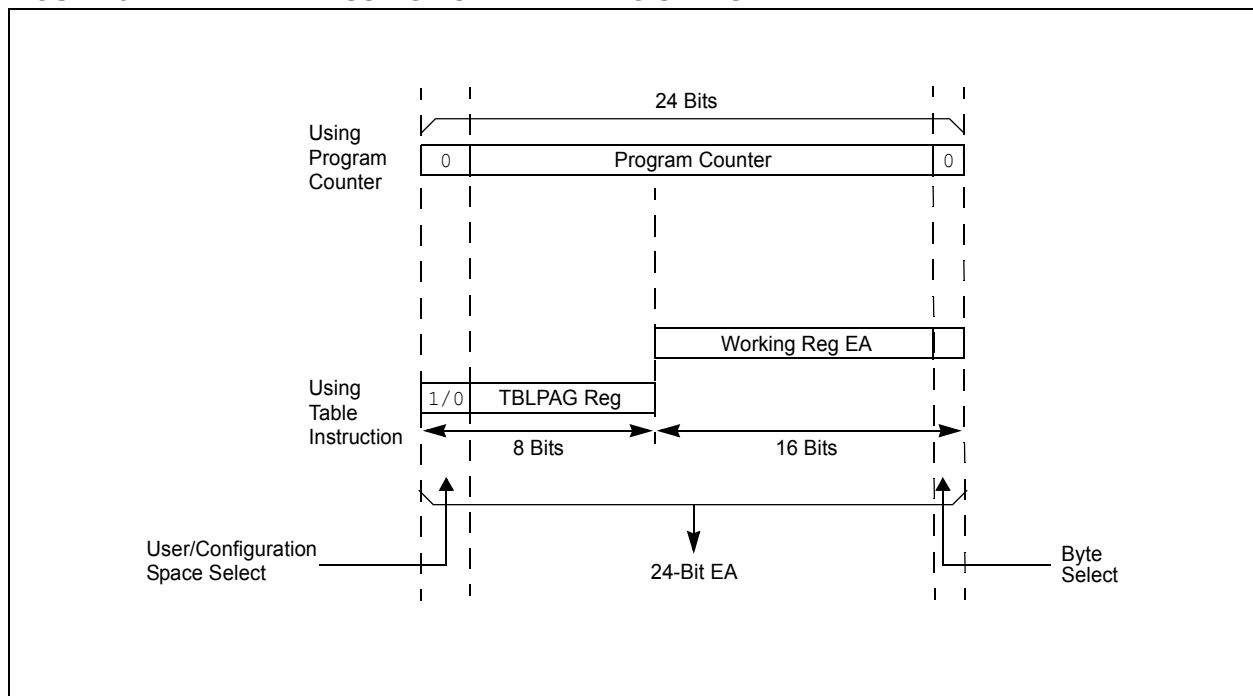
### 5.1 Table Instructions and Flash Programming

Regardless of the method used, all programming of Flash memory is done with the table read and table write instructions. These allow direct read and write access to the program memory space from the data memory while the device is in normal operating mode. The 24-bit target address in the program memory is formed using the TBLPAG[7:0] bits and the Effective Address (EA) from a W register specified in the table instruction, as shown in Figure 5-1.

The TBLRDL and the TBLWTL instructions are used to read or write to bits[15:0] of program memory. TBLRDL and TBLWTL can access program memory in both Word and Byte modes.

The TBLRDH and TBLWTH instructions are used to read or write to bits[23:16] of program memory. TBLRDH and TBLWTH can also access program memory in Word or Byte mode.

FIGURE 5-1: ADDRESSING FOR TABLE REGISTERS



# PIC24FJ256GA110 FAMILY

---

## 5.2 RTSP Operation

The PIC24F Flash program memory array is organized into rows of 64 instructions or 192 bytes. RTSP allows the user to erase blocks of eight rows (512 instructions) at a time and to program one row at a time. It is also possible to program single words.

The 8-row erase blocks and single row write blocks are edge-aligned, from the beginning of program memory, on boundaries of 1536 bytes and 192 bytes, respectively.

When data are written to program memory using `TBLWT` instructions, the data are not written directly to memory. Instead, data written using table writes are stored in holding latches until the programming sequence is executed.

Any number of `TBLWT` instructions can be executed and a write will be successfully performed. However, 64 `TBLWT` instructions are required to write the full row of memory.

To ensure that no data are corrupted during a write, any unused addresses should be programmed with `FFFFFFh`. This is because the holding latches reset to an unknown state, so if the addresses are left in the Reset state, they may overwrite the locations on rows which were not rewritten.

The basic sequence for RTSP programming is to set up a Table Pointer, then do a series of `TBLWT` instructions to load the buffers. Programming is performed by setting the control bits in the `NVMCON` register.

Data can be loaded in any order and the holding registers can be written to multiple times before performing a write operation. Subsequent writes, however, will wipe out any previous writes.

**Note:** Writing to a location multiple times without erasing is *not* recommended.

All of the table write operations are single word writes (2 instruction cycles), because only the buffers are written. A programming cycle is required for programming each row.

## 5.3 JTAG Operation

The PIC24F family supports JTAG boundary scan. Boundary scan can improve the manufacturing process by verifying pin to PCB connectivity.

## 5.4 Enhanced In-Circuit Serial Programming

Enhanced In-Circuit Serial Programming uses an on-board bootloader, known as the program executive, to manage the programming process. Using an SPI data frame format, the program executive can erase, program and verify program memory. For more information on Enhanced ICSP, see the device programming specification.

## 5.5 Control Registers

There are two SFRs used to read and write the program Flash memory: `NVMCON` and `NVMKEY`.

The `NVMCON` register ([Register 5-1](#)) controls which blocks are to be erased, which memory type is to be programmed and when the programming cycle starts.

`NVMKEY` is a write-only register that is used for write protection. To start a programming or erase sequence, the user must consecutively write `55h` and `AAh` to the `NVMKEY` register. Refer to [Section 5.6 “Programming Operations”](#) for further details.

## 5.6 Programming Operations

A complete programming sequence is necessary for programming or erasing the internal Flash in RTSP mode. During a programming or erase operation, the processor Stalls (Waits) until the operation is finished. Setting the `WR` bit (`NVMCON[15]`) starts the operation and the `WR` bit is automatically cleared when the operation is finished.

# PIC24FJ256GA110 FAMILY

## REGISTER 5-1: NVMCON: FLASH MEMORY CONTROL REGISTER

R/SO-0 <sup>(1)</sup>	R/W-0 <sup>(1)</sup>	R/W-0 <sup>(1)</sup>	U-0	U-0	U-0	U-0	U-0
WR	WREN	WRERR	—	—	—	—	—
bit 15							bit 8

U-0	R/W-0 <sup>(1)</sup>	U-0	U-0	R/W-0 <sup>(1)</sup>	R/W-0 <sup>(1)</sup>	R/W-0 <sup>(1)</sup>	R/W-0 <sup>(1)</sup>
—	ERASE	—	—	NVMOP3 <sup>(2)</sup>	NVMOP2 <sup>(2)</sup>	NVMOP1 <sup>(2)</sup>	NVMOP0 <sup>(2)</sup>
bit 7							bit 0

<b>Legend:</b>	SO = Set Only bit
R = Readable bit	W = Writable bit
-n = Value at POR	'1' = Bit is set
	U = Unimplemented bit, read as '0'
	'0' = Bit is cleared
	x = Bit is unknown

- bit 15     **WR:** Write Control bit<sup>(1)</sup>  
 1 = Initiates a Flash memory program or erase operation. The operation is self-timed and the bit is cleared by hardware once the operation is complete.  
 0 = Program or erase operation is complete and inactive
- bit 14     **WREN:** Write Enable bit<sup>(1)</sup>  
 1 = Enable Flash program/erase operations  
 0 = Inhibit Flash program/erase operations
- bit 13     **WRERR:** Write Sequence Error Flag bit<sup>(1)</sup>  
 1 = An improper program or erase sequence attempt or termination has occurred (bit is set automatically on any set attempt of the WR bit)  
 0 = The program or erase operation completed normally
- bit 12-7   **Unimplemented:** Read as '0'
- bit 6     **ERASE:** Erase/Program Enable bit<sup>(1)</sup>  
 1 = Perform the erase operation specified by NVMOP[3:0] on the next WR command  
 0 = Perform the program operation specified by NVMOP[3:0] on the next WR command
- bit 5-4    **Unimplemented:** Read as '0'
- bit 3-0    **NVMOP[3:0]:** NVM Operation Select bits<sup>(1,2)</sup>  
 1111 = Memory bulk erase operation (ERASE = 1) or no operation (ERASE = 0)<sup>(3)</sup>  
 0011 = Memory word program operation (ERASE = 0) or no operation (ERASE = 1)  
 0010 = Memory page erase operation (ERASE = 1) or no operation (ERASE = 0)  
 0001 = Memory row program operation (ERASE = 0) or no operation (ERASE = 1)

- Note 1:** These bits can only be reset on POR.  
**2:** All other combinations of NVMOP[3:0] are unimplemented.  
**3:** Available in ICSP™ mode only. Refer to the device programming specification.

# PIC24FJ256GA110 FAMILY

## 5.6.1 PROGRAMMING ALGORITHM FOR FLASH PROGRAM MEMORY

The user can program one row of Flash program memory at a time. To do this, it is necessary to erase the 8-row erase block containing the desired row. The general process is as follows:

1. Read eight rows of program memory (512 instructions) and store in data RAM.
2. Update the program data in RAM with the desired new data.
3. Erase the block (see [Example 5-1](#) for an implementation in assembler):
  - a) Set the NVMOPx bits (NVMCON[3:0]) to '0010' to configure for block erase. Set the ERASE (NVMCON[6]) and WREN (NVMCON[14]) bits.
  - b) Write the starting address of the block to be erased into the TBLPAG and W registers.
  - c) Write 55h to NVMKEY.
  - d) Write AAh to NVMKEY.
  - e) Set the WR bit (NVMCON[15]). The erase cycle begins and the CPU Stalls for the duration of the erase cycle. When the erase is done, the WR bit is cleared automatically.
4. Write the first 64 instructions from data RAM into the program memory buffers (see [Example 5-3](#) for the implementation in assembler).

5. Write the program block to Flash memory:
  - a) Set the NVMOPx bits to '0001' to configure for row programming. Clear the ERASE bit and set the WREN bit.
  - b) Write 55h to NVMKEY.
  - c) Write AAh to NVMKEY.
  - d) Set the WR bit. The programming cycle begins and the CPU Stalls for the duration of the write cycle. When the write to Flash memory is done, the WR bit is cleared automatically.
6. Repeat Steps 4 and 5, using the next available 64 instructions from the block in data RAM by incrementing the value in TBLPAG, until all 512 instructions are written back to Flash memory.

For protection against accidental operations, the write initiate sequence for NVMKEY must be used to allow any erase or program operation to proceed. After the programming command has been executed, the user must wait for the programming time until programming is complete. The two instructions following the start of the programming sequence should be NOPs, as shown in [Example 5-5](#).

**Note:** The equivalent C code for these steps, prepared using Microchip's MPLAB® C30 compiler and a specific library of built-in hardware functions, is shown in [Examples 5-2, 5-4 and 5-6](#).

### EXAMPLE 5-1: ERASING A PROGRAM MEMORY BLOCK (ASSEMBLY LANGUAGE CODE)

```
; Set up NVMCON for block erase operation
MOV    #0x4042, W0                ;
MOV    W0, NVMCON                 ; Initialize NVMCON
; Init pointer to row to be ERASED
MOV    #tblpage(PROG_ADDR), W0    ;
MOV    W0, TBLPAG                 ; Initialize PM Page Boundary SFR
MOV    #tbloffset(PROG_ADDR), W0 ; Initialize in-page EA[15:0] pointer
TBLWTL W0, [W0]                  ; Set base address of erase block
DISI   #5                         ; Block all interrupts with priority <7
                                           ; for next 5 instructions

MOV    #0x55, W0
MOV    W0, NVMKEY                 ; Write the 55 key
MOV    #0xAA, W1
MOV    W1, NVMKEY                 ; Write the AA key
BSET   NVMCON, #WR                ; Start the erase sequence
NOP                                         ; Insert two NOPs after the erase
NOP                                         ; command is asserted
```

# PIC24FJ256GA110 FAMILY

## EXAMPLE 5-2: ERASING A PROGRAM MEMORY BLOCK (C LANGUAGE CODE)

```
// C example using MPLAB C30
unsigned long progAddr = 0XXXXXXX;    // Address of row to write
unsigned int offset;

//Set up pointer to the first memory location to be written
TBLPAG = progAddr>>16;                // Initialize PM Page Boundary SFR
offset = progAddr & 0xFFFF;          // Initialize lower word of address

__builtin_tblwtl(offset, 0x0000);     // Set base address of erase block
                                        // with dummy latch write

NVMCON = 0x4042;                      // Initialize NVMCON

asm("DISI #5");                       // Block all interrupts with priority <7
                                        // for next 5 instructions
__builtin_write_NVM();                // C30 function to perform unlock
                                        // sequence and set WR
```

## EXAMPLE 5-3: LOADING THE WRITE BUFFERS (ASSEMBLY LANGUAGE CODE)

```
; Set up NVMCON for row programming operations
MOV    #0x4001, W0                    ;
MOV    W0, NVMCON                    ; Initialize NVMCON
; Set up a pointer to the first program memory location to be written
; program memory selected, and writes enabled
MOV    #0x0000, W0                    ;
MOV    W0, TBLPAG                    ; Initialize PM Page Boundary SFR
MOV    #0x6000, W0                    ; An example program memory address
; Perform the TBLWT instructions to write the latches
; 0th_program_word
MOV    #LOW_WORD_0, W2                ;
MOV    #HIGH_BYTE_0, W3                ;
TBLWTL W2, [W0]                      ; Write PM low word into program latch
TBLWTH W3, [W0++]                    ; Write PM high byte into program latch
; 1st_program_word
MOV    #LOW_WORD_1, W2                ;
MOV    #HIGH_BYTE_1, W3                ;
TBLWTL W2, [W0]                      ; Write PM low word into program latch
TBLWTH W3, [W0++]                    ; Write PM high byte into program latch
; 2nd_program_word
MOV    #LOW_WORD_2, W2                ;
MOV    #HIGH_BYTE_2, W3                ;
TBLWTL W2, [W0]                      ; Write PM low word into program latch
TBLWTH W3, [W0++]                    ; Write PM high byte into program latch
.
.
.
; 63rd_program_word
MOV    #LOW_WORD_31, W2                ;
MOV    #HIGH_BYTE_31, W3                ;
TBLWTL W2, [W0]                      ; Write PM low word into program latch
TBLWTH W3, [W0]                      ; Write PM high byte into program latch
```

# PIC24FJ256GA110 FAMILY

## EXAMPLE 5-4: LOADING THE WRITE BUFFERS (C LANGUAGE CODE)

```
// C example using MPLAB C30

#define NUM_INSTRUCTION_PER_ROW 64
unsigned int offset;
unsigned int i;
unsigned long progAddr = 0XXXXXXX;           // Address of row to write
unsigned int progData[2*NUM_INSTRUCTION_PER_ROW]; // Buffer of data to write

//Set up NVMCON for row programming
NVMCON = 0x4001;                             // Initialize NVMCON

//Set up pointer to the first memory location to be written
TBLPAG = progAddr>>16;                       // Initialize PM Page Boundary SFR
offset = progAddr & 0xFFFF;                 // Initialize lower word of address

//Perform TBLWT instructions to write necessary number of latches
for(i=0; i < 2*NUM_INSTRUCTION_PER_ROW; i++)
{
    __builtin_tblwtl(offset, progData[i++]); // Write to address low word
    __builtin_tblwth(offset, progData[i]);   // Write to upper byte
    offset = offset + 2;                    // Increment address
}
```

## EXAMPLE 5-5: INITIATING A PROGRAMMING SEQUENCE (ASSEMBLY LANGUAGE CODE)

```
DISI    #5                                ; Block all interrupts with priority <7
                                                ; for next 5 instructions
MOV     #0x55, W0                          ; Write the 55 key
MOV     W0, NVMKEY                          ;
MOV     #0xAA, W1                          ;
MOV     W1, NVMKEY                          ; Write the AA key
BSET    NVMCON, #WR                        ; Start the erase sequence
NOP                                           ;
NOP                                           ;
BTSC    NVMCON, #15                        ; and wait for it to be
BRA     $-2                                 ; completed
```

## EXAMPLE 5-6: INITIATING A PROGRAMMING SEQUENCE (C LANGUAGE CODE)

```
// C example using MPLAB C30

asm("DISI #5");                             // Block all interrupts with priority < 7
                                                // for next 5 instructions

__builtin_write_NVM();                       // Perform unlock sequence and set WR
```

# PIC24FJ256GA110 FAMILY

## 5.6.2 PROGRAMMING A SINGLE WORD OF FLASH PROGRAM MEMORY

If a Flash location has been erased, it can be programmed using table write instructions to write an instruction word (24-bit) into the write latch. The TBLPAG register is loaded with the eight Most Significant Bytes of the Flash address. The TBLWTL and TBLWTH instructions write the desired data into the

write latches and specify the lower 16 bits of the program memory address to write to. To configure the NVMCON register for a word write, set the NVMOPx bits (NVMCON[3:0]) to '0011'. The write is performed by executing the unlock sequence and setting the WR bit, as shown in [Example 5-7](#). An equivalent procedure in C, using the MPLAB C30 compiler and built-in hardware functions, is shown in [Example 5-8](#).

### EXAMPLE 5-7: PROGRAMMING A SINGLE WORD OF FLASH PROGRAM MEMORY (ASSEMBLY LANGUAGE CODE)

```
; Setup a pointer to data Program Memory
MOV    #tblpage(PROG_ADDR), W0      ;
MOV    W0, TBLPAG                  ; Initialize PM Page Boundary SFR
MOV    #tbloffset(PROG_ADDR), W0   ; Initialize a register with program memory address

MOV    #LOW_WORD, W2                ;
MOV    #HIGH_BYTE, W3              ;
TBLWTL W2, [W0]                    ; Write PM low word into program latch
TBLWTH W3, [W0++]                  ; Write PM high byte into program latch

; Setup NVMCON for programming one word to data Program Memory
MOV    #0x4003, W0                  ;
MOV    W0, NVMCON                  ; Set NVMOP bits to 0011

DISI   #5                            ; Disable interrupts while the KEY sequence is written
MOV    #0x55, W0                    ; Write the key sequence
MOV    W0, NVMKEY
MOV    #0xAA, W0
MOV    W0, NVMKEY
BSET   NVMCON, #WR                  ; Start the write cycle
NOP                                         ; Insert two NOPs after the erase
NOP                                         ; Command is asserted
```

### EXAMPLE 5-8: PROGRAMMING A SINGLE WORD OF FLASH PROGRAM MEMORY (C LANGUAGE CODE)

```
// C example using MPLAB C30

unsigned int offset;
unsigned long progAddr = 0xFFFFFFFF; // Address of word to program
unsigned int progDataL = 0xFFFF;    // Data to program lower word
unsigned char progDataH = 0xFF;      // Data to program upper byte

//Set up NVMCON for word programming
NVMCON = 0x4003; // Initialize NVMCON

//Set up pointer to the first memory location to be written
TBLPAG = progAddr>>16; // Initialize PM Page Boundary SFR
offset = progAddr & 0xFFFF; // Initialize lower word of address

//Perform TBLWT instructions to write latches
__builtin_tblwtl(offset, progDataL); // Write to address low word
__builtin_tblwth(offset, progDataH); // Write to upper byte
asm("DISI #5"); // Block interrupts with priority < 7
// for next 5 instructions
__builtin_write_NVM(); // C30 function to perform unlock
// sequence and set WR
```

# PIC24FJ256GA110 FAMILY

---

NOTES:

# PIC24FJ256GA110 FAMILY

## 6.0 RESETS

**Note:** This data sheet summarizes the features of this group of PIC24F devices. It is not intended to be a comprehensive reference source. For more information, refer to “Reset” ([www.microchip.com/DS39712](http://www.microchip.com/DS39712)) in the “dsPIC33/PIC24 Family Reference Manual”. The information in this data sheet supersedes the information in the FRM.

The Reset module combines all Reset sources and controls the device Master Reset Signal,  $\overline{\text{SYSRST}}$ . The following is a list of device Reset sources:

- POR: Power-on Reset
- MCLR: Pin Reset
- SWR: RESET Instruction
- WDT: Watchdog Timer Reset
- BOR: Brown-out Reset
- CM: Configuration Mismatch Reset
- TRAPR: Trap Conflict Reset
- IOPUWR: Illegal Opcode Reset
- UWR: Uninitialized W Register Reset

A simplified block diagram of the Reset module is shown in Figure 6-1.

Any active source of Reset will make the  $\overline{\text{SYSRST}}$  signal active. Many registers associated with the CPU and peripherals are forced to a known Reset state. Most registers are unaffected by a Reset; their status is unknown on POR and unchanged by all other Resets.

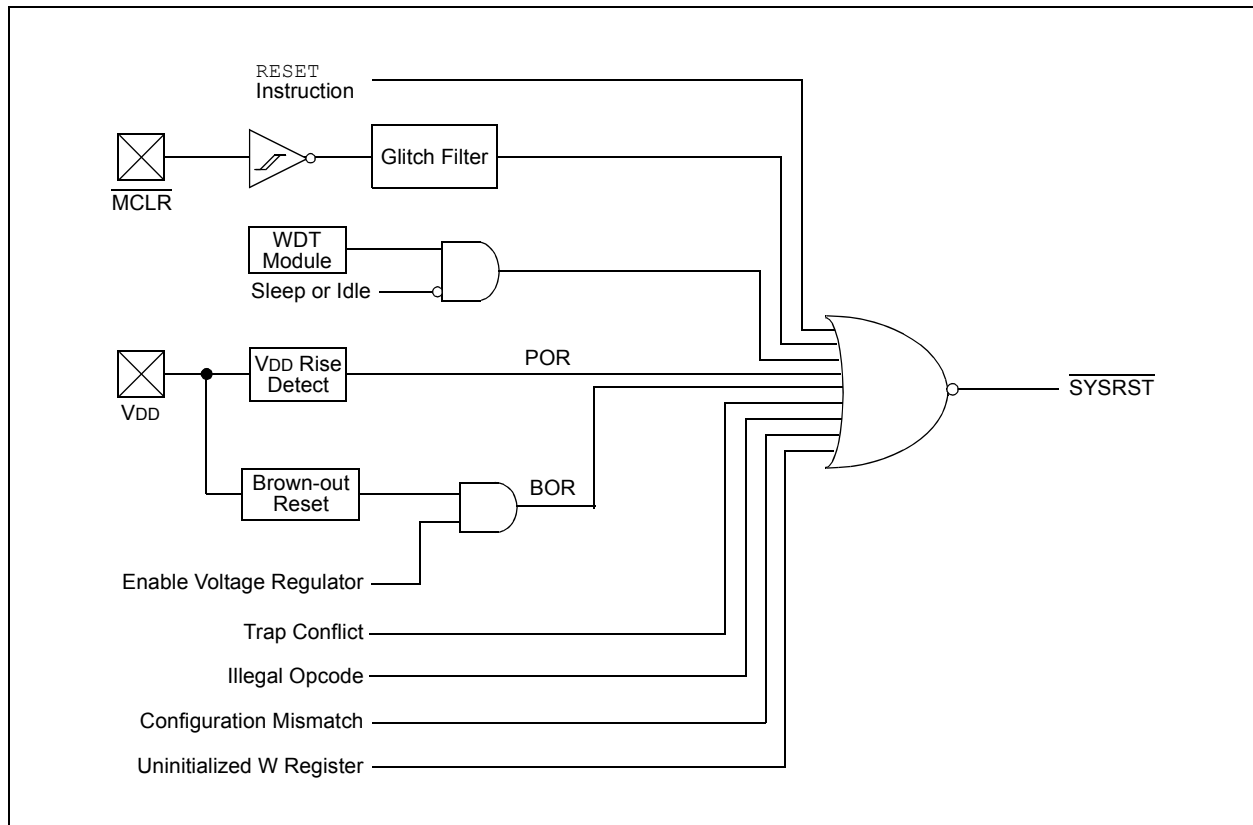
**Note:** Refer to the specific peripheral or CPU section of this manual for register Reset states.

All types of device Reset will set a corresponding status bit in the RCON register to indicate the type of Reset (see Register 6-1). A Power-on Reset will clear all bits except for the BOR and POR bits (RCON[1:0]) which are set. The user may set or clear any bit at any time during code execution. The RCON bits only serve as status bits. Setting a particular Reset status bit in software will not cause a device Reset to occur.

The RCON register also has other bits associated with the Watchdog Timer and device power-saving states. The function of these bits is discussed in other sections of this data sheet.

**Note:** The status bits in the RCON register should be cleared after they are read so that the next RCON register value after a device Reset will be meaningful.

**FIGURE 6-1: RESET SYSTEM BLOCK DIAGRAM**



# PIC24FJ256GA110 FAMILY

## REGISTER 6-1: RCON: RESET CONTROL REGISTER<sup>(1)</sup>

R/W-0	R/W-0	U-0	U-0	U-0	U-0	R/W-0	R/W-0
TRAPR	IOPUWR	—	—	—	—	CM	PMSLP
bit 15						bit 8	

R/W-0	R/W-0	R/W-0	R/W-0	R/W-0	R/W-0	R/W-1	R/W-1
EXTR	SWR	SWDTEN <sup>(2)</sup>	WDTO	SLEEP	IDLE	BOR	POR
bit 7						bit 0	

### Legend:

R = Readable bit

W = Writable bit

U = Unimplemented bit, read as '0'

-n = Value at POR

'1' = Bit is set

'0' = Bit is cleared

x = Bit is unknown

- bit 15     **TRAPR:** Trap Reset Flag bit  
           1 = A Trap Conflict Reset has occurred  
           0 = A Trap Conflict Reset has not occurred
- bit 14     **IOPUWR:** Illegal Opcode or Uninitialized W Access Reset Flag bit  
           1 = An illegal opcode detection, an illegal address mode or uninitialized W register used as an Address Pointer caused a Reset  
           0 = An illegal opcode or uninitialized W Reset has not occurred
- bit 13-10   **Unimplemented:** Read as '0'
- bit 9       **CM:** Configuration Word Mismatch Reset Flag bit  
           1 = A Configuration Word Mismatch Reset has occurred  
           0 = A Configuration Word Mismatch Reset has not occurred
- bit 8       **PMSLP:** Program Memory Power During Sleep bit  
           1 = Program memory bias voltage remains powered during Sleep  
           0 = Program memory bias voltage is powered down during Sleep and voltage regulator enters Standby mode
- bit 7       **EXTR:** External Reset ( $\overline{\text{MCLR}}$ ) Pin bit  
           1 = A Master Clear (pin) Reset has occurred  
           0 = A Master Clear (pin) Reset has not occurred
- bit 6       **SWR:** Software Reset (Instruction) Flag bit  
           1 = A `RESET` instruction has been executed  
           0 = A `RESET` instruction has not been executed
- bit 5       **SWDTEN:** Software Enable/Disable of WDT bit<sup>(2)</sup>  
           1 = WDT is enabled  
           0 = WDT is disabled
- bit 4       **WDTO:** Watchdog Timer Time-out Flag bit  
           1 = WDT time-out has occurred  
           0 = WDT time-out has not occurred
- bit 3       **SLEEP:** Wake From Sleep Flag bit  
           1 = Device has been in Sleep mode  
           0 = Device has not been in Sleep mode
- bit 2       **IDLE:** Wake-up From Idle Flag bit  
           1 = Device has been in Idle mode  
           0 = Device has not been in Idle mode
- bit 1       **BOR:** Brown-out Reset Flag bit  
           1 = A Brown-out Reset has occurred; note that BOR is also set after a Power-on Reset  
           0 = A Brown-out Reset has not occurred

# PIC24FJ256GA110 FAMILY

## REGISTER 6-1: RCON: RESET CONTROL REGISTER<sup>(1)</sup> (CONTINUED)

bit 0      **POR:** Power-on Reset Flag bit  
           1 = A Power-on Reset has occurred  
           0 = A Power-on Reset has not occurred

- Note 1:** All of the Reset status bits may be set or cleared in software. Setting one of these bits in software does not cause a device Reset.
- 2:** If the FWDTEN Configuration bit is '1' (unprogrammed), the WDT is always enabled, regardless of the SWDTEN bit setting.

**TABLE 6-1: RESET FLAG BIT OPERATION**

Flag Bit	Setting Event	Clearing Event
TRAPR (RCON[15])	Trap Conflict Event	POR
IOPUWR (RCON[14])	Illegal Opcode or Uninitialized W Register Access	POR
CM (RCON[9])	Configuration Mismatch Reset	POR
EXTR (RCON[7])	MCLR Reset	POR
SWR (RCON[6])	RESET Instruction	POR
WDTO (RCON[4])	WDT Time-out	PWRSV Instruction, POR, CLRWDT
SLEEP (RCON[3])	PWRSV #SLEEP Instruction	POR
IDLE (RCON[2])	PWRSV #IDLE Instruction	POR
BOR (RCON[1])	POR, BOR	—
POR (RCON[0])	POR	—

**Note:** All Reset flag bits may be set or cleared by the user software.

### 6.1 Clock Source Selection at Reset

If clock switching is enabled, the system clock source at device Reset is chosen as shown in [Table 6-2](#). If clock switching is disabled, the system clock source is always selected according to the oscillator Configuration bits. Refer to [Section 8.0 “Oscillator Configuration”](#) for further details.

**TABLE 6-2: OSCILLATOR SELECTION vs. TYPE OF RESET (CLOCK SWITCHING ENABLED)**

Reset Type	Clock Source Determinant
POR	FNOSC <sub>x</sub> Configuration bits (CW2[10:8])
BOR	
MCLR	COS <sub>Cx</sub> Control bits (OSCCON[14:12])
WDTO	
SWR	

### 6.2 Device Reset Times

The Reset times for various types of device Reset are summarized in [Table 6-3](#). Note that the system Reset signal, SYSRST, is released after the POR and PWRT delay times expire.

The time at which the device actually begins to execute code will also depend on the system oscillator delays, which include the Oscillator Start-up Timer (OST) and the PLL lock time. The OST and PLL lock times occur in parallel with the applicable SYSRST delay times.

The FSCM delay determines the time at which the FSCM begins to monitor the system clock source after the SYSRST signal is released.

# PIC24FJ256GA110 FAMILY

**TABLE 6-3: RESET DELAY TIMES FOR VARIOUS DEVICE RESETS**

Reset Type	Clock Source	$\overline{\text{SYSRST}}$ Delay	System Clock Delay	Notes
POR <sup>(6)</sup>	EC	TPOR + TPWRT + TRST	—	1, 2, 7
	FRC, FRCDIV	TPOR + TPWRT + TRST	TFRC	1, 2, 3, 7
	LPRC	TPOR + TPWRT + TRST	TLPRC	1, 2, 3, 7
	ECPLL	TPOR + TPWRT + TRST	TLOCK	1, 2, 4, 7
	FRCPLL	TPOR + TPWRT + TRST	TFRC + TLOCK	1, 2, 3, 4, 7
	XT, HS, SOSC	TPOR + TPWRT + TRST	TOST	1, 2, 5, 7
	XTPLL, HSPLL	TPOR + TPWRT + TRST	TOST + TLOCK	1, 2, 4, 5, 7
BOR	EC	TPWRT + TRST	—	2, 7
	FRC, FRCDIV	TPWRT + TRST	TFRC	2, 3, 7
	LPRC	TPWRT + TRST	TLPRC	2, 3, 7
	ECPLL	TPWRT + TRST	TLOCK	2, 4, 7
	FRCPLL	TPWRT + TRST	TFRC + TLOCK	2, 3, 4, 7
	XT, HS, SOSC	TPWRT + TRST	TOST	2, 5, 7
	XTPLL, HSPLL	TPWRT + TRST	TFRC + TLOCK	2, 3, 4, 7
All Others	Any Clock	TRST	—	7

**Note 1:** TPOR = Power-on Reset delay.

**2:** TPWRT = 64 ms nominal if regulator is disabled (ENVREG tied to Vss).

**3:** TFRC and TLPRC = RC Oscillator start-up times.

**4:** TLOCK = PLL lock time.

**5:** TOST = Oscillator Start-up Timer (OST). A 10-bit counter waits 1024 oscillator periods before releasing the oscillator clock to the system.

**6:** If Two-Speed Start-up is enabled, regardless of the Primary Oscillator selected, the device starts with FRC, and in such cases, FRC start-up time is valid.

**7:** TRST = Internal State Reset Timer

**Note:** For detailed operating frequency and timing specifications, see [Section 28.0 “Electrical Characteristics”](#).

## 6.2.1 POR AND LONG OSCILLATOR START-UP TIMES

The oscillator start-up circuitry and its associated delay timers are not linked to the device Reset delays that occur at power-up. Some crystal circuits (especially low-frequency crystals) will have a relatively long start-up time. Therefore, one or more of the following conditions is possible after `SYSRST` is released:

- The oscillator circuit has not begun to oscillate.
- The Oscillator Start-up Timer has not expired (if a crystal oscillator is used).
- The PLL has not achieved a lock (if PLL is used).

The device will not begin to execute code until a valid clock source has been released to the system. Therefore, the oscillator and PLL start-up delays must be considered when the Reset delay time must be known.

## 6.2.2 FAIL-SAFE CLOCK MONITOR (FSCM) AND DEVICE RESETS

If the FSCM is enabled, it will begin to monitor the system clock source when `SYSRST` is released. If a valid clock source is not available at this time, the device will automatically switch to the FRC Oscillator and the user can switch to the desired crystal oscillator in the Trap Service Routine (TSR).

## 6.3 Special Function Register Reset States

Most of the Special Function Registers (SFRs) associated with the PIC24F CPU and peripherals are reset to a particular value at a device Reset. The SFRs are grouped by their peripheral or CPU function and their Reset values are specified in each section of this manual.

The Reset value for each SFR does not depend on the type of Reset with the exception of four registers. The Reset value for the Reset Control register, `RCON`, will depend on the type of device Reset. The Reset value for the Oscillator Control register, `OSCCON`, will depend on the type of Reset and the programmed values of the `FNOSC` bits in Flash Configuration Word 2 (CW2); see [Table 6-2](#). The `RCFGCAL` and `NVMCON` registers are only affected by a POR.

# PIC24FJ256GA110 FAMILY

---

NOTES:

# PIC24FJ256GA110 FAMILY

## 7.0 INTERRUPT CONTROLLER

**Note:** This data sheet summarizes the features of this group of PIC24F devices. It is not intended to be a comprehensive reference source. For more information, refer to “**Interrupts**” ([www.microchip.com/DS70000600](http://www.microchip.com/DS70000600)) in the “*dsPIC33/PIC24 Family Reference Manual*”. The information in this data sheet supersedes the information in the FRM.

The PIC24F interrupt controller reduces the numerous peripheral interrupt request signals to a single interrupt request signal to the PIC24F CPU. It has the following features:

- Up to Eight Processor Exceptions and Software Traps
- Seven User-Selectable Priority Levels
- Interrupt Vector Table (IVT) with Up to 118 Vectors
- A Unique Vector for Each Interrupt or Exception Source
- Fixed Priority within a Specified User Priority Level
- Alternate Interrupt Vector Table (AIVT) for Debug Support
- Fixed Interrupt Entry and Return Latencies

### 7.1 Interrupt Vector Table

The Interrupt Vector Table (IVT) is shown in [Figure 7-1](#). The IVT resides in program memory, starting at location 000004h. The IVT contains 126 vectors, consisting of eight non-maskable trap vectors, plus up to 118 sources of interrupt. In general, each interrupt source has its own vector. Each interrupt vector contains a 24-bit wide address. The value programmed into each interrupt vector location is the starting address of the associated Interrupt Service Routine (ISR).

Interrupt vectors are prioritized in terms of their natural priority; this is linked to their position in the vector table. All other things being equal, lower addresses have a higher natural priority. For example, the interrupt associated with Vector 0 will take priority over interrupts at any other vector address.

PIC24FJ256GA110 family devices implement non-maskable traps and unique interrupts. These are summarized in [Table 7-1](#) and [Table 7-2](#).

### 7.1.1 ALTERNATE INTERRUPT VECTOR TABLE

The Alternate Interrupt Vector Table (AIVT) is located after the IVT, as shown in [Figure 7-1](#). Access to the AIVT is provided by the ALTIVT control bit (INTCON2[15]). If the ALTIVT bit is set, all interrupt and exception processes will use the alternate vectors instead of the default vectors. The alternate vectors are organized in the same manner as the default vectors.

The AIVT supports emulation and debugging efforts by providing a means to switch between an application and a support environment without requiring the interrupt vectors to be reprogrammed. This feature also enables switching between applications for evaluation of different software algorithms at run time. If the AIVT is not needed, the AIVT should be programmed with the same addresses used in the IVT.

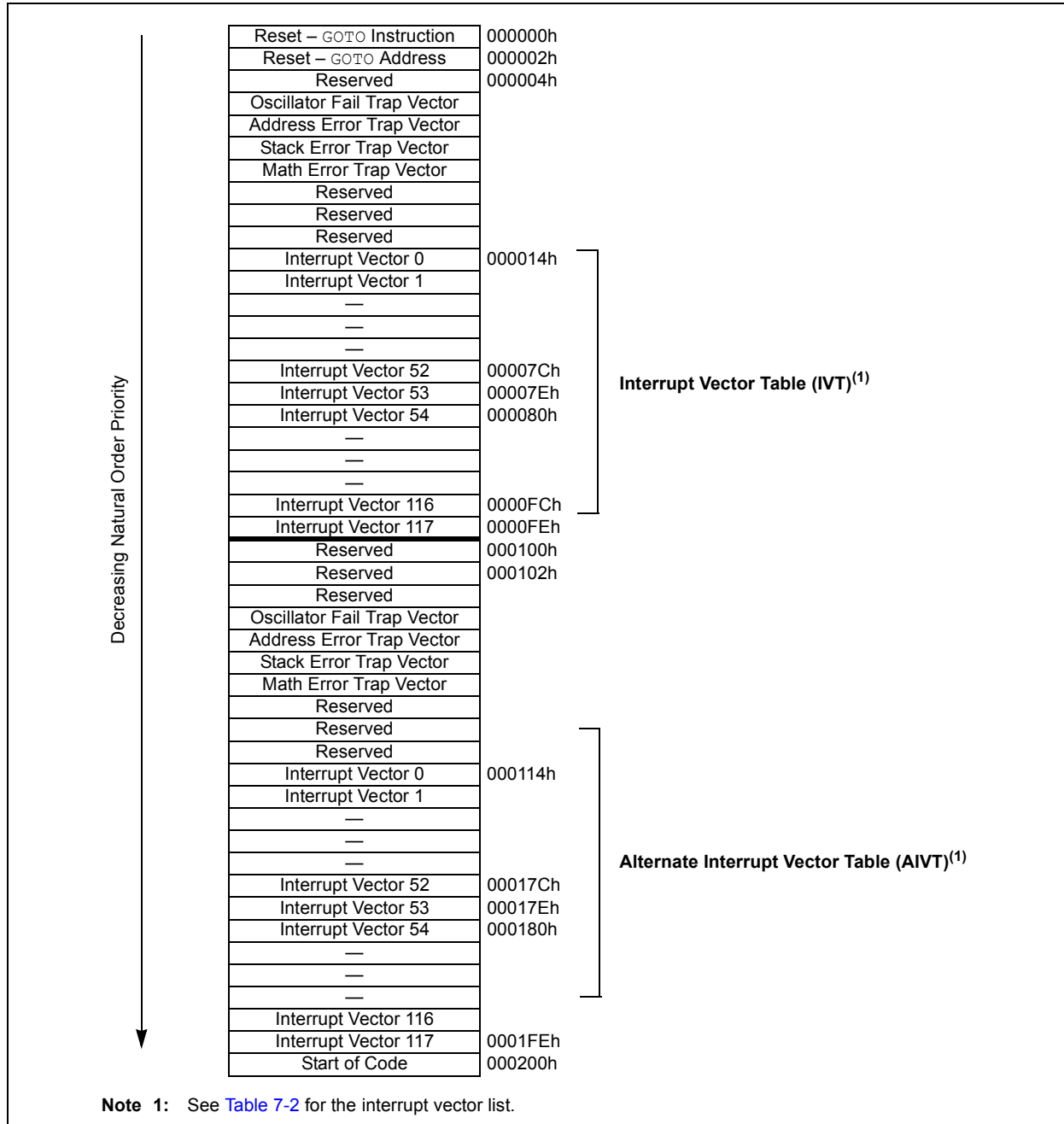
### 7.2 Reset Sequence

A device Reset is not a true exception because the interrupt controller is not involved in the Reset process. The PIC24F devices clear their registers in response to a Reset which forces the PC to zero. The microcontroller then begins program execution at location, 000000h. The user programs a `GOTO` instruction at the Reset address, which redirects program execution to the appropriate start-up routine.

**Note:** Any unimplemented or unused vector locations in the IVT and AIVT should be programmed with the address of a default interrupt handler routine that contains a `RESET` instruction.

# PIC24FJ256GA110 FAMILY

**FIGURE 7-1: PIC24F INTERRUPT VECTOR TABLE**



**TABLE 7-1: TRAP VECTOR DETAILS**

Vector Number	IVT Address	AIVT Address	Trap Source
0	000004h	000104h	Reserved
1	000006h	000106h	Oscillator Failure
2	000008h	000108h	Address Error
3	00000Ah	00010Ah	Stack Error
4	00000Ch	00010Ch	Math Error
5	00000Eh	00010Eh	Reserved
6	000010h	000110h	Reserved
7	000012h	000112h	Reserved

# PIC24FJ256GA110 FAMILY

**TABLE 7-2: IMPLEMENTED INTERRUPT VECTORS**

Interrupt Source	MPLAB® XC16 ISR Name	Vector #	IRQ #	IVT Address	AIVT Address	Interrupt Bit Locations		
						Flag	Enable	Priority
External Interrupt 0	_INT0Interrupt	8	0	000014h	000114h	IFS0[0]	IEC0[0]	IPC0[2:0]
Input Capture 1	_IC1Interrupt	9	1	000016h	000116h	IFS0[1]	IEC0[1]	IPC0[6:4]
Output Compare 1	_OC1Interrupt	10	2	000018h	000118h	IFS0[2]	IEC0[2]	IPC0[10:8]
Timer1	_T1Interrupt	11	3	00001Ah	00011Ah	IFS0[3]	IEC0[3]	IPC0[14:12]
Reserved	Reserved	12	4	00001Ch	00011Ch	—	—	—
Input Capture 2	_IC2Interrupt	13	5	00001Eh	00011Eh	IFS0[5]	IEC0[5]	IPC1[6:4]
Output Compare 2	_OC2Interrupt	14	6	000020h	000120h	IFS0[6]	IEC0[6]	IPC1[10:8]
Timer2	_T2Interrupt	15	7	000022h	000122h	IFS0[7]	IEC0[7]	IPC1[14:12]
Timer3	_T3Interrupt	16	8	000024h	000124h	IFS0[8]	IEC0[8]	IPC2[2:0]
SPI1 Error	_SPI1ErrInterrupt	17	9	000026h	000126h	IFS0[9]	IEC0[9]	IPC2[6:4]
SPI1 Event	_SPI1Interrupt	18	10	000028h	000128h	IFS0[10]	IEC0[10]	IPC2[10:8]
UART1 Receiver	_U1RXInterrupt	19	11	00002Ah	00012Ah	IFS0[11]	IEC0[11]	IPC2[14:12]
UART1 Transmitter	_U1TXInterrupt	20	12	00002Ch	00012Ch	IFS0[12]	IEC0[12]	IPC3[2:0]
ADC1 Conversion Done	_ADC1Interrupt	21	13	00002Eh	00012Eh	IFS0[13]	IEC0[13]	IPC3[6:4]
Reserved	Reserved	22-23	14-15	000030h- 000032h	000130h- 000132h	—	—	—
I2C1 Slave Event	_SI2C1Interrupt	24	16	000034h	000134h	IFS1[0]	IEC1[0]	IPC4[2:0]
I2C1 Master Event	_MI2C1Interrupt	25	17	000036h	000136h	IFS1[1]	IEC1[1]	IPC4[6:4]
Comparator Event	_CompInterrupt	26	18	000038h	000138h	IFS1[2]	IEC1[2]	IPC4[10:8]
Input Change Notification	_CNInterrupt	27	19	00003Ah	00013Ah	IFS1[3]	IEC1[3]	IPC4[14:12]
External Interrupt 1	_INT1Interrupt	28	20	00003Ch	00013Ch	IFS1[4]	IEC1[4]	IPC5[2:0]
Reserved	Reserved	29	21	00003Eh	00013Eh	—	—	—
Input Capture 7	_IC7Interrupt	30	22	000040h	000140h	IFS1[6]	IEC1[6]	IPC5[10:8]
Input Capture 8	_IC8Interrupt	31	23	000042h	000142h	IFS1[7]	IEC1[7]	IPC5[14:12]
Reserved	Reserved	32	24	000044h	000144h	—	—	—
Output Compare 3	_OC3Interrupt	33	25	000046h	000146h	IFS1[9]	IEC1[9]	IPC6[6:4]
Output Compare 4	_OC4Interrupt	34	26	000048h	000148h	IFS1[10]	IEC1[10]	IPC6[10:8]
Timer4	_T4Interrupt	35	27	00004Ah	00014Ah	IFS1[11]	IEC1[11]	IPC6[14:12]
Timer5	_T5Interrupt	36	28	00004Ch	00014Ch	IFS1[12]	IEC1[12]	IPC7[2:0]
External Interrupt 2	_INT2Interrupt	37	29	00004Eh	00014Eh	IFS1[13]	IEC1[13]	IPC7[6:4]
UART2 Receiver	_U2RXInterrupt	38	30	000050h	000150h	IFS1[14]	IEC1[14]	IPC7[10:8]
UART2 Transmitter	_U2TXInterrupt	39	31	000052h	000152h	IFS1[15]	IEC1[15]	IPC7[14:12]
SPI2 Error	_SPI2ErrInterrupt	40	32	000054h	000154h	IFS2[0]	IEC2[0]	IPC8[2:0]
SPI2 Event	_SPI2Interrupt	41	33	000056h	000156h	IFS2[1]	IEC2[1]	IPC8[6:4]
Reserved	Reserved	42-44	34-36	000058h- 00005Ch	000158h- 00015Ch	—	—	—
Input Capture 3	_IC3Interrupt	45	37	00005Eh	00015Eh	IFS2[5]	IEC2[5]	IPC9[6:4]
Input Capture 4	_IC4Interrupt	46	38	000060h	000160h	IFS2[6]	IEC2[6]	IPC9[10:8]
Input Capture 5	_IC5Interrupt	47	39	000062h	000162h	IFS2[7]	IEC2[7]	IPC9[14:12]
Input Capture 6	_IC6Interrupt	48	40	000064h	000164h	IFS2[8]	IEC2[8]	IPC10[2:0]
Output Compare 5	_OC5Interrupt	49	41	000066h	000166h	IFS2[9]	IEC2[9]	IPC10[6:4]
Output Compare 6	_OC6Interrupt	50	42	000068h	000168h	IFS2[10]	IEC2[10]	IPC10[10:8]
Output Compare 7	_OC7Interrupt	51	43	00006Ah	00016Ah	IFS2[11]	IEC2[11]	IPC10[14:12]
Output Compare 8	_OC8Interrupt	52	44	00006Ch	00016Ch	IFS2[12]	IEC2[12]	IPC11[2:0]
Parallel Master Port	_PMPInterrupt	53	45	00006Eh	00016Eh	IFS2[13]	IEC2[13]	IPC11[6:4]
Reserved	Reserved	54-56	46-48	000070h- 000074h	000170h- 000174h	—	—	—

# PIC24FJ256GA110 FAMILY

**TABLE 7-2: IMPLEMENTED INTERRUPT VECTORS (CONTINUED)**

Interrupt Source	MPLAB® XC16 ISR Name	Vector #	IRQ #	IVT Address	AIVT Address	Interrupt Bit Locations		
						Flag	Enable	Priority
I2C2 Slave Event	_SI2C2Interrupt	57	49	000076h	000176h	IFS3[1]	IEC3[1]	IPC12[6:4]
I2C2 Master Event	_MI2C2Interrupt	58	50	000078h	000178h	IFS3[2]	IEC3[2]	IPC12[10:8]
Reserved	Reserved	59-60	51-52	00007Ah- 00007Ch	00017Ah- 00017Ch	—	—	—
External Interrupt 3	_INT3Interrupt	61	53	00007Eh	00017Eh	IFS3[5]	IEC3[5]	IPC13[6:4]
External Interrupt 4	_INT4Interrupt	62	54	000080h	000180h	IFS3[6]	IEC3[6]	IPC13[10:8]
Reserved	Reserved	63-69	55-61	000082h- 00008Eh	000182h- 00018Eh	—	—	—
Real-Time Clock/Calendar	_RTCCInterrupt	70	62	000090h	000190h	IFS3[14]	IEC3[14]	IPC15[10:8]
Reserved	Reserved	71-72	63-64	000092h- 000094h	000192h- 000194h	—	—	—
UART1 Error	_U1ErrInterrupt	73	65	000096h	000196h	IFS4[1]	IEC4[1]	IPC16[6:4]
UART2 Error	_U2ErrInterrupt	74	66	000098h	000198h	IFS4[2]	IEC4[2]	IPC16[10:8]
CRC Generator	_CRCInterrupt	75	67	00009Ah	00019Ah	IFS4[3]	IEC4[3]	IPC16[14:12]
Reserved	Reserved	76-79	68-71	00009Ch- 0000A2h	00019Ch- 0001A2h	—	—	—
LVD Low-Voltage Detect	_LVDInterrupt	80	72	0000A4h	0001A4h	IFS4[8]	IEC4[8]	IPC18[2:0]
Reserved	Reserved	81-84	73-76	0000A6h- 0000ACh	0001A6h- 0001ACh	—	—	—
CTMU Event	_CTMUInterrupt	85	77	0000AEh	0001AEh	IFS4[13]	IEC4[13]	IPC19[6:4]
Reserved	Reserved	86-88	78-80	0000B0h- 0000B4h	0001B0h- 0001B4h	—	—	—
UART3 Error	_U3ErrInterrupt	89	81	0000B6h	0001B6h	IFS5[1]	IEC5[1]	IPC20[6:4]
UART3 Receiver	_U3RXInterrupt	90	82	0000B8h	0001B8h	IFS5[2]	IEC5[2]	IPC20[10:8]
UART3 Transmitter	_U3TXInterrupt	91	83	0000BAh	0001BAh	IFS5[3]	IEC5[3]	IPC20[14:12]
I2C3 Slave Event	_SI2C3Interrupt	92	84	0000BCh	0001BCh	IFS5[4]	IEC5[4]	IPC21[2:0]
I2C3 Master Event	_MI2C3Interrupt	93	85	0000BEh	0001BEh	IFS5[5]	IEC5[5]	IPC21[6:4]
Reserved	Reserved	94	86	0000C0h	0001C0h	—	—	—
UART4 Error	_U4ErrInterrupt	95	87	0000C2h	0001C2h	IFS5[7]	IEC5[7]	IPC21[14:12]
UART4 Receiver	_U4RXInterrupt	96	88	0000C4h	0001C4h	IFS5[8]	IEC5[8]	IPC22[2:0]
UART4 Transmitter	_U4TXInterrupt	97	89	0000C6h	0001C6h	IFS5[9]	IEC5[9]	IPC22[6:4]
SPI3 Error	_SPI3ErrInterrupt	98	90	0000C8h	0001C8h	IFS5[10]	IEC5[10]	IPC22[10:8]
SPI3 Event	_SPI3Interrupt	99	91	0000CAh	0001CAh	IFS5[11]	IEC5[11]	IPC22[14:12]
Output Compare 9	_OC9Interrupt	100	92	0000CCh	0001CCh	IFS5[12]	IEC5[12]	IPC23[2:0]
Input Capture 9	_IC9Interrupt	101	93	0000CEh	0001CEh	IFS5[13]	IEC5[13]	IPC23[6:4]

## 7.3 Interrupt Control and Status Registers

The PIC24FJ256GA110 family of devices implements a total of 37 registers for the interrupt controller:

- INTCON1
- INTCON2
- IFS0 through IFS5
- IEC0 through IEC5
- IPC0 through IPC23 (except IPC14 and IPC17)
- INTTREG

Global interrupt control functions are controlled from INTCON1 and INTCON2. INTCON1 contains the Interrupt Nesting Disable (NSTDIS) bit, as well as the control and status flags for the processor trap sources. The INTCON2 register controls the external interrupt request signal behavior and the use of the Alternate Interrupt Vector Table.

The IFSx registers maintain all of the interrupt request flags. Each source of interrupt has a status bit which is set by the respective peripherals, or an external signal, and is cleared via software.

The IECx registers maintain all of the interrupt enable bits. These control bits are used to individually enable interrupts from the peripherals or external signals.

The IPCx registers are used to set the Interrupt Priority Level (IPL) for each source of interrupt. Each user interrupt source can be assigned to one of eight priority levels.

The INTTREG register contains the associated interrupt vector number and the new CPU Interrupt Priority Level, which are latched into the Vector Number (VECNUM[6:0]) and the Interrupt Level (ILR[3:0]) bit fields in the INTTREG register. The new Interrupt Priority Level is the priority of the pending interrupt.

The interrupt sources are assigned to the IFSx, IECx and IPCx registers in the order of their vector numbers, as shown in [Table 7-2](#). For example, the INT0 (External Interrupt 0) is shown as having a vector number and a natural order priority of 0. Thus, the INT0IF status bit is found in IFS0[0], the INT0IE enable bit in IEC0[0] and the INT0IP[2:0] priority bits in the first position of IPC0 (IPC0[2:0]).

Although they are not specifically part of the interrupt control hardware, two of the CPU control registers contain bits that control interrupt functionality. The ALU STATUS Register (SR) contains the IPL[2:0] bits (SR[7:5]); these indicate the current CPU Interrupt Priority Level. The user may change the current CPU priority level by writing to the IPLx bits.

The CORCON register contains the IPL3 bit, which together with IPL[2:0], indicates the current CPU priority level. IPL3 is a read-only bit so that trap events cannot be masked by the user software.

All Interrupt registers are described in [Register 7-1](#) through [Register 7-38](#), on the following pages.

# PIC24FJ256GA110 FAMILY

## REGISTER 7-1: SR: ALU STATUS REGISTER (IN CPU)

U-0	U-0	U-0	U-0	U-0	U-0	U-0	R-0
—	—	—	—	—	—	—	DC <sup>(1)</sup>
bit 15							bit 8

R/W-0	R/W-0	R/W-0	R-0	R/W-0	R/W-0	R/W-0	R/W-0
IPL2 <sup>(2,3)</sup>	IPL1 <sup>(2,3)</sup>	IPL0 <sup>(2,3)</sup>	RA <sup>(1)</sup>	N <sup>(1)</sup>	OV <sup>(1)</sup>	Z <sup>(1)</sup>	C <sup>(1)</sup>
bit 7							bit 0

### Legend:

R = Readable bit                      W = Writable bit                      U = Unimplemented bit, read as '0'  
 -n = Value at POR                      '1' = Bit is set                      '0' = Bit is cleared                      x = Bit is unknown

bit 7-5                      **IPL[2:0]:** CPU Interrupt Priority Level Status bits<sup>(2,3)</sup>

111 = CPU Interrupt Priority Level is 7 (15). User interrupts disabled.  
 110 = CPU Interrupt Priority Level is 6 (14)  
 101 = CPU Interrupt Priority Level is 5 (13)  
 100 = CPU Interrupt Priority Level is 4 (12)  
 011 = CPU Interrupt Priority Level is 3 (11)  
 010 = CPU Interrupt Priority Level is 2 (10)  
 001 = CPU Interrupt Priority Level is 1 (9)  
 000 = CPU Interrupt Priority Level is 0 (8)

- Note 1:** See [Register 3-1](#) for the description of the remaining bit(s) that are not dedicated to interrupt control functions.
- 2:** The IPLx bits are concatenated with the IPL3 bit (CORCON[3]) to form the CPU Interrupt Priority Level. The value in parentheses indicates the Interrupt Priority Level if IPL3 = 1.
- 3:** The IPLx Status bits are read-only when NSTDIS (INTCON1[15]) = 1.

## REGISTER 7-2: CORCON: CPU CONTROL REGISTER

U-0	U-0	U-0	U-0	U-0	U-0	U-0	U-0
—	—	—	—	—	—	—	—
bit 15							bit 8

U-0	U-0	U-0	U-0	R/C-0	R/W-0	U-0	U-0
—	—	—	—	IPL3 <sup>(2)</sup>	PSV <sup>(1)</sup>	—	—
bit 7							bit 0

### Legend:

C = Clearable bit  
 R = Readable bit                      W = Writable bit                      U = Unimplemented bit, read as '0'  
 -n = Value at POR                      '1' = Bit is set                      '0' = Bit is cleared                      x = Bit is unknown

bit 3                      **IPL3:** CPU Interrupt Priority Level Status bit<sup>(2)</sup>

1 = CPU Interrupt Priority Level is greater than 7  
 0 = CPU Interrupt Priority Level is 7 or less

- Note 1:** See [Register 3-2](#) for the description of the remaining bit(s) that are not dedicated to interrupt control functions.
- 2:** The IPL3 bit is concatenated with the IPL[2:0] bits (SR[7:5]) to form the CPU Interrupt Priority Level.

# PIC24FJ256GA110 FAMILY

## REGISTER 7-3: INTCON1: INTERRUPT CONTROL REGISTER 1

R/W-0	U-0	U-0	U-0	U-0	U-0	U-0	U-0
NSTDIS	—	—	—	—	—	—	—
bit 15							bit 8

U-0	U-0	U-0	R/W-0	R/W-0	R/W-0	R/W-0	U-0
—	—	—	MATHERR	ADDRERR	STKERR	OSCFAIL	—
bit 7							bit 0

<b>Legend:</b>			
R = Readable bit	W = Writable bit	U = Unimplemented bit, read as '0'	
-n = Value at POR	'1' = Bit is set	'0' = Bit is cleared	x = Bit is unknown

- bit 15      **NSTDIS:** Interrupt Nesting Disable bit  
                  1 = Interrupt nesting is disabled  
                  0 = Interrupt nesting is enabled
- bit 14-5    **Unimplemented:** Read as '0'
- bit 4        **MATHERR:** Arithmetic Error Trap Status bit  
                  1 = Overflow trap has occurred  
                  0 = Overflow trap has not occurred
- bit 3        **ADDRERR:** Address Error Trap Status bit  
                  1 = Address error trap has occurred  
                  0 = Address error trap has not occurred
- bit 2        **STKERR:** Stack Error Trap Status bit  
                  1 = Stack error trap has occurred  
                  0 = Stack error trap has not occurred
- bit 1        **OSCFAIL:** Oscillator Failure Trap Status bit  
                  1 = Oscillator failure trap has occurred  
                  0 = Oscillator failure trap has not occurred
- bit 0        **Unimplemented:** Read as '0'

# PIC24FJ256GA110 FAMILY

## REGISTER 7-4: INTCON2: INTERRUPT CONTROL REGISTER 2

R/W-0	R-0	U-0	U-0	U-0	U-0	U-0	U-0
ALTIVT	DISI	—	—	—	—	—	—
bit 15							bit 8

U-0	U-0	U-0	R/W-0	R/W-0	R/W-0	R/W-0	R/W-0
—	—	—	INT4EP	INT3EP	INT2EP	INT1EP	INT0EP
bit 7							bit 0

### Legend:

R = Readable bit      W = Writable bit      U = Unimplemented bit, read as '0'  
 -n = Value at POR      '1' = Bit is set      '0' = Bit is cleared      x = Bit is unknown

- bit 15      **ALTIVT:** Enable Alternate Interrupt Vector Table bit  
             1 = Use Alternate Interrupt Vector Table  
             0 = Use standard (default) vector table
- bit 14      **DISI:** DISI Instruction Status bit  
             1 = DISI instruction is active  
             0 = DISI instruction is not active
- bit 13-5    **Unimplemented:** Read as '0'
- bit 4      **INT4EP:** External Interrupt 4 Edge Detect Polarity Select bit  
             1 = Interrupt on negative edge  
             0 = Interrupt on positive edge
- bit 3      **INT3EP:** External Interrupt 3 Edge Detect Polarity Select bit  
             1 = Interrupt on negative edge  
             0 = Interrupt on positive edge
- bit 2      **INT2EP:** External Interrupt 2 Edge Detect Polarity Select bit  
             1 = Interrupt on negative edge  
             0 = Interrupt on positive edge
- bit 1      **INT1EP:** External Interrupt 1 Edge Detect Polarity Select bit  
             1 = Interrupt on negative edge  
             0 = Interrupt on positive edge
- bit 0      **INT0EP:** External Interrupt 0 Edge Detect Polarity Select bit  
             1 = Interrupt on negative edge  
             0 = Interrupt on positive edge

# PIC24FJ256GA110 FAMILY

## REGISTER 7-5: IFS0: INTERRUPT FLAG STATUS REGISTER 0

U-0	U-0	R/W-0	R/W-0	R/W-0	R/W-0	R/W-0	R/W-0
—	—	AD1IF	U1TXIF	U1RXIF	SPI1IF	SPF1IF	T3IF
bit 15							bit 8
R/W-0	R/W-0	R/W-0	U-0	R/W-0	R/W-0	R/W-0	R/W-0
T2IF	OC2IF	IC2IF	—	T1IF	OC1IF	IC1IF	INT0IF
bit 7							bit 0

### Legend:

R = Readable bit	W = Writable bit	U = Unimplemented bit, read as '0'
-n = Value at POR	'1' = Bit is set	'0' = Bit is cleared
		x = Bit is unknown

- bit 15-14    **Unimplemented:** Read as '0'
- bit 13      **AD1IF:** A/D Conversion Complete Interrupt Flag Status bit  
1 = Interrupt request has occurred  
0 = Interrupt request has not occurred
- bit 12      **U1TXIF:** UART1 Transmitter Interrupt Flag Status bit  
1 = Interrupt request has occurred  
0 = Interrupt request has not occurred
- bit 11      **U1RXIF:** UART1 Receiver Interrupt Flag Status bit  
1 = Interrupt request has occurred  
0 = Interrupt request has not occurred
- bit 10      **SPI1IF:** SPI1 Event Interrupt Flag Status bit  
1 = Interrupt request has occurred  
0 = Interrupt request has not occurred
- bit 9        **SPF1IF:** SPI1 Fault Interrupt Flag Status bit  
1 = Interrupt request has occurred  
0 = Interrupt request has not occurred
- bit 8        **T3IF:** Timer3 Interrupt Flag Status bit  
1 = Interrupt request has occurred  
0 = Interrupt request has not occurred
- bit 7        **T2IF:** Timer2 Interrupt Flag Status bit  
1 = Interrupt request has occurred  
0 = Interrupt request has not occurred
- bit 6        **OC2IF:** Output Compare Channel 2 Interrupt Flag Status bit  
1 = Interrupt request has occurred  
0 = Interrupt request has not occurred
- bit 5        **IC2IF:** Input Capture Channel 2 Interrupt Flag Status bit  
1 = Interrupt request has occurred  
0 = Interrupt request has not occurred
- bit 4        **Unimplemented:** Read as '0'
- bit 3        **T1IF:** Timer1 Interrupt Flag Status bit  
1 = Interrupt request has occurred  
0 = Interrupt request has not occurred
- bit 2        **OC1IF:** Output Compare Channel 1 Interrupt Flag Status bit  
1 = Interrupt request has occurred  
0 = Interrupt request has not occurred
- bit 1        **IC1IF:** Input Capture Channel 1 Interrupt Flag Status bit  
1 = Interrupt request has occurred  
0 = Interrupt request has not occurred
- bit 0        **INT0IF:** External Interrupt 0 Flag Status bit  
1 = Interrupt request has occurred  
0 = Interrupt request has not occurred

# PIC24FJ256GA110 FAMILY

## REGISTER 7-6: IFS1: INTERRUPT FLAG STATUS REGISTER 1

R/W-0	R/W-0	R/W-0	R/W-0	R/W-0	R/W-0	R/W-0	U-0
U2TXIF	U2RXIF	INT2IF	T5IF	T4IF	OC4IF	OC3IF	—
bit 15							bit 8

R/W-0	R/W-0	U-0	R/W-0	R/W-0	R/W-0	R/W-0	R/W-0
IC8IF	IC7IF	—	INT1IF	CNIF	CMIF	MI2C1IF	SI2C1IF
bit 7							bit 0

### Legend:

R = Readable bit  
-n = Value at POR

W = Writable bit  
'1' = Bit is set

U = Unimplemented bit, read as '0'  
'0' = Bit is cleared  
x = Bit is unknown

- bit 15      **U2TXIF:** UART2 Transmitter Interrupt Flag Status bit  
1 = Interrupt request has occurred  
0 = Interrupt request has not occurred
- bit 14      **U2RXIF:** UART2 Receiver Interrupt Flag Status bit  
1 = Interrupt request has occurred  
0 = Interrupt request has not occurred
- bit 13      **INT2IF:** External Interrupt 2 Flag Status bit  
1 = Interrupt request has occurred  
0 = Interrupt request has not occurred
- bit 12      **T5IF:** Timer5 Interrupt Flag Status bit  
1 = Interrupt request has occurred  
0 = Interrupt request has not occurred
- bit 11      **T4IF:** Timer4 Interrupt Flag Status bit  
1 = Interrupt request has occurred  
0 = Interrupt request has not occurred
- bit 10      **OC4IF:** Output Compare Channel 4 Interrupt Flag Status bit  
1 = Interrupt request has occurred  
0 = Interrupt request has not occurred
- bit 9        **OC3IF:** Output Compare Channel 3 Interrupt Flag Status bit  
1 = Interrupt request has occurred  
0 = Interrupt request has not occurred
- bit 8        **Unimplemented:** Read as '0'
- bit 7        **IC8IF:** Input Capture Channel 8 Interrupt Flag Status bit  
1 = Interrupt request has occurred  
0 = Interrupt request has not occurred
- bit 6        **IC7IF:** Input Capture Channel 7 Interrupt Flag Status bit  
1 = Interrupt request has occurred  
0 = Interrupt request has not occurred
- bit 5        **Unimplemented:** Read as '0'
- bit 4        **INT1IF:** External Interrupt 1 Flag Status bit  
1 = Interrupt request has occurred  
0 = Interrupt request has not occurred
- bit 3        **CNIF:** Input Change Notification Interrupt Flag Status bit  
1 = Interrupt request has occurred  
0 = Interrupt request has not occurred
- bit 2        **CMIF:** Comparator Interrupt Flag Status bit  
1 = Interrupt request has occurred  
0 = Interrupt request has not occurred
- bit 1        **MI2C1IF:** Master I2C1 Event Interrupt Flag Status bit  
1 = Interrupt request has occurred  
0 = Interrupt request has not occurred
- bit 0        **SI2C1IF:** Slave I2C1 Event Interrupt Flag Status bit  
1 = Interrupt request has occurred  
0 = Interrupt request has not occurred

# PIC24FJ256GA110 FAMILY

## REGISTER 7-7: IFS2: INTERRUPT FLAG STATUS REGISTER 2

U-0	U-0	R/W-0	R/W-0	R/W-0	R/W-0	R/W-0	R/W-0
—	—	PMPiF	OC8iF	OC7iF	OC6iF	OC5iF	IC6iF
bit 15							bit 8

R/W-0	R/W-0	R/W-0	U-0	U-0	U-0	R/W-0	R/W-0
IC5iF	IC4iF	IC3iF	—	—	—	SPI2iF	SPF2iF
bit 7							bit 0

### Legend:

R = Readable bit                      W = Writable bit                      U = Unimplemented bit, read as '0'  
 -n = Value at POR                      '1' = Bit is set                      '0' = Bit is cleared                      x = Bit is unknown

- bit 15-14    **Unimplemented:** Read as '0'
- bit 13      **PMPiF:** Parallel Master Port Interrupt Flag Status bit  
               1 = Interrupt request has occurred  
               0 = Interrupt request has not occurred
- bit 12      **OC8iF:** Output Compare Channel 8 Interrupt Flag Status bit  
               1 = Interrupt request has occurred  
               0 = Interrupt request has not occurred
- bit 11      **OC7iF:** Output Compare Channel 7 Interrupt Flag Status bit  
               1 = Interrupt request has occurred  
               0 = Interrupt request has not occurred
- bit 10      **OC6iF:** Output Compare Channel 6 Interrupt Flag Status bit  
               1 = Interrupt request has occurred  
               0 = Interrupt request has not occurred
- bit 9        **OC5iF:** Output Compare Channel 5 Interrupt Flag Status bit  
               1 = Interrupt request has occurred  
               0 = Interrupt request has not occurred
- bit 8        **IC6iF:** Input Capture Channel 6 Interrupt Flag Status bit  
               1 = Interrupt request has occurred  
               0 = Interrupt request has not occurred
- bit 7        **IC5iF:** Input Capture Channel 5 Interrupt Flag Status bit  
               1 = Interrupt request has occurred  
               0 = Interrupt request has not occurred
- bit 6        **IC4iF:** Input Capture Channel 4 Interrupt Flag Status bit  
               1 = Interrupt request has occurred  
               0 = Interrupt request has not occurred
- bit 5        **IC3iF:** Input Capture Channel 3 Interrupt Flag Status bit  
               1 = Interrupt request has occurred  
               0 = Interrupt request has not occurred
- bit 4-2     **Unimplemented:** Read as '0'
- bit 1        **SPI2iF:** SPI2 Event Interrupt Flag Status bit  
               1 = Interrupt request has occurred  
               0 = Interrupt request has not occurred
- bit 0        **SPF2iF:** SPI2 Fault Interrupt Flag Status bit  
               1 = Interrupt request has occurred  
               0 = Interrupt request has not occurred

# PIC24FJ256GA110 FAMILY

## REGISTER 7-8: IFS3: INTERRUPT FLAG STATUS REGISTER 3

U-0	R/W-0	U-0	U-0	U-0	U-0	U-0	U-0
—	RTCIF	—	—	—	—	—	—
bit 15							bit 8

U-0	R/W-0	R/W-0	U-0	U-0	R/W-0	R/W-0	U-0
—	INT4IF	INT3IF	—	—	MI2C2IF	SI2C2IF	—
bit 7							bit 0

### Legend:

R = Readable bit

W = Writable bit

U = Unimplemented bit, read as '0'

-n = Value at POR

'1' = Bit is set

'0' = Bit is cleared

x = Bit is unknown

- bit 15      **Unimplemented:** Read as '0'
- bit 14      **RTCIF:** Real-Time Clock/Calendar Interrupt Flag Status bit  
             1 = Interrupt request has occurred  
             0 = Interrupt request has not occurred
- bit 13-7    **Unimplemented:** Read as '0'
- bit 6        **INT4IF:** External Interrupt 4 Flag Status bit  
             1 = Interrupt request has occurred  
             0 = Interrupt request has not occurred
- bit 5        **INT3IF:** External Interrupt 3 Flag Status bit  
             1 = Interrupt request has occurred  
             0 = Interrupt request has not occurred
- bit 4-3     **Unimplemented:** Read as '0'
- bit 2        **MI2C2IF:** Master I2C2 Event Interrupt Flag Status bit  
             1 = Interrupt request has occurred  
             0 = Interrupt request has not occurred
- bit 1        **SI2C2IF:** Slave I2C2 Event Interrupt Flag Status bit  
             1 = Interrupt request has occurred  
             0 = Interrupt request has not occurred
- bit 0        **Unimplemented:** Read as '0'

# PIC24FJ256GA110 FAMILY

## REGISTER 7-9: IFS4: INTERRUPT FLAG STATUS REGISTER 4

U-0	U-0	R/W-0	U-0	U-0	U-0	U-0	R/W-0
—	—	CTMUIF	—	—	—	—	LVDIF
bit 15							bit 8

U-0	U-0	U-0	U-0	R/W-0	R/W-0	R/W-0	U-0
—	—	—	—	CRCIF	U2ERIF	U1ERIF	—
bit 7							bit 0

### Legend:

R = Readable bit                      W = Writable bit                      U = Unimplemented bit, read as '0'  
 -n = Value at POR                      '1' = Bit is set                      '0' = Bit is cleared                      x = Bit is unknown

- bit 15-14    **Unimplemented:** Read as '0'
- bit 13      **CTMUIF:** CTMU Interrupt Flag Status bit  
                   1 = Interrupt request has occurred  
                   0 = Interrupt request has not occurred
- bit 12-9    **Unimplemented:** Read as '0'
- bit 8        **LVDIF:** Low-Voltage Detect Interrupt Flag Status bit  
                   1 = Interrupt request has occurred  
                   0 = Interrupt request has not occurred
- bit 7-4     **Unimplemented:** Read as '0'
- bit 3        **CRCIF:** CRC Generator Interrupt Flag Status bit  
                   1 = Interrupt request has occurred  
                   0 = Interrupt request has not occurred
- bit 2        **U2ERIF:** UART2 Error Interrupt Flag Status bit  
                   1 = Interrupt request has occurred  
                   0 = Interrupt request has not occurred
- bit 1        **U1ERIF:** UART1 Error Interrupt Flag Status bit  
                   1 = Interrupt request has occurred  
                   0 = Interrupt request has not occurred
- bit 0        **Unimplemented:** Read as '0'

# PIC24FJ256GA110 FAMILY

## REGISTER 7-10: IFS5: INTERRUPT FLAG STATUS REGISTER 5

U-0	U-0	R/W-0	R/W-0	R/W-0	R/W-0	R/W-0	R/W-0
—	—	IC9IF	OC9IF	SPI3IF	SPF3IF	U4TXIF	U4RXIF
bit 15							bit 8

R/W-0	U-0	R/W-0	R/W-0	R/W-0	R/W-0	R/W-0	U-0
U4ERIF	—	MI2C3IF	SI2C3IF	U3TXIF	U3RXIF	U3ERIF	—
bit 7							bit 0

### Legend:

R = Readable bit	W = Writable bit	U = Unimplemented bit, read as '0'
-n = Value at POR	'1' = Bit is set	'0' = Bit is cleared
		x = Bit is unknown

- bit 15-14 **Unimplemented:** Read as '0'
- bit 13 **IC9IF:** Input Capture Channel 9 Interrupt Flag Status bit
  - 1 = Interrupt request has occurred
  - 0 = Interrupt request has not occurred
- bit 12 **OC9IF:** Output Compare Channel 9 Interrupt Flag Status bit
  - 1 = Interrupt request has occurred
  - 0 = Interrupt request has not occurred
- bit 11 **SPI3IF:** SPI3 Event Interrupt Flag Status bit
  - 1 = Interrupt request has occurred
  - 0 = Interrupt request has not occurred
- bit 10 **SPF3IF:** SPI3 Fault Interrupt Flag Status bit
  - 1 = Interrupt request has occurred
  - 0 = Interrupt request has not occurred
- bit 9 **U4TXIF:** UART4 Transmitter Interrupt Flag Status bit
  - 1 = Interrupt request has occurred
  - 0 = Interrupt request has not occurred
- bit 8 **U4RXIF:** UART4 Receiver Interrupt Flag Status bit
  - 1 = Interrupt request has occurred
  - 0 = Interrupt request has not occurred
- bit 7 **U4ERIF:** UART4 Error Interrupt Flag Status bit
  - 1 = Interrupt request has occurred
  - 0 = Interrupt request has not occurred
- bit 6 **Unimplemented:** Read as '0'
- bit 5 **MI2C3IF:** Master I2C3 Event Interrupt Flag Status bit
  - 1 = Interrupt request has occurred
  - 0 = Interrupt request has not occurred
- bit 4 **SI2C3IF:** Slave I2C3 Event Interrupt Flag Status bit
  - 1 = Interrupt request has occurred
  - 0 = Interrupt request has not occurred
- bit 3 **U3TXIF:** UART3 Transmitter Interrupt Flag Status bit
  - 1 = Interrupt request has occurred
  - 0 = Interrupt request has not occurred
- bit 2 **U3RXIF:** UART3 Receiver Interrupt Flag Status bit
  - 1 = Interrupt request has occurred
  - 0 = Interrupt request has not occurred
- bit 1 **U3ERIF:** UART3 Error Interrupt Flag Status bit
  - 1 = Interrupt request has occurred
  - 0 = Interrupt request has not occurred
- bit 0 **Unimplemented:** Read as '0'

# PIC24FJ256GA110 FAMILY

## REGISTER 7-11: IEC0: INTERRUPT ENABLE CONTROL REGISTER 0

U-0	U-0	R/W-0	R/W-0	R/W-0	R/W-0	R/W-0	R/W-0
—	—	AD1IE	U1TXIE	U1RXIE	SPI1IE	SPF1IE	T3IE
bit 15							bit 8

R/W-0	R/W-0	R/W-0	U-0	R/W-0	R/W-0	R/W-0	R/W-0
T2IE	OC2IE	IC2IE	—	T1IE	OC1IE	IC1IE	INT0IE
bit 7							bit 0

### Legend:

R = Readable bit                      W = Writable bit                      U = Unimplemented bit, read as '0'  
 -n = Value at POR                      '1' = Bit is set                      '0' = Bit is cleared                      x = Bit is unknown

- bit 15-14    **Unimplemented:** Read as '0'
- bit 13      **AD1IE:** A/D Conversion Complete Interrupt Enable bit  
                  1 = Interrupt request enabled  
                  0 = Interrupt request not enabled
- bit 12      **U1TXIE:** UART1 Transmitter Interrupt Enable bit  
                  1 = Interrupt request enabled  
                  0 = Interrupt request not enabled
- bit 11      **U1RXIE:** UART1 Receiver Interrupt Enable bit  
                  1 = Interrupt request enabled  
                  0 = Interrupt request not enabled
- bit 10      **SPI1IE:** SPI1 Transfer Complete Interrupt Enable bit  
                  1 = Interrupt request enabled  
                  0 = Interrupt request not enabled
- bit 9        **SPF1IE:** SPI1 Fault Interrupt Enable bit  
                  1 = Interrupt request enabled  
                  0 = Interrupt request not enabled
- bit 8        **T3IE:** Timer3 Interrupt Enable bit  
                  1 = Interrupt request enabled  
                  0 = Interrupt request not enabled
- bit 7        **T2IE:** Timer2 Interrupt Enable bit  
                  1 = Interrupt request enabled  
                  0 = Interrupt request not enabled
- bit 6        **OC2IE:** Output Compare Channel 2 Interrupt Enable bit  
                  1 = Interrupt request enabled  
                  0 = Interrupt request not enabled
- bit 5        **IC2IE:** Input Capture Channel 2 Interrupt Enable bit  
                  1 = Interrupt request enabled  
                  0 = Interrupt request not enabled
- bit 4        **Unimplemented:** Read as '0'
- bit 3        **T1IE:** Timer1 Interrupt Enable bit  
                  1 = Interrupt request enabled  
                  0 = Interrupt request not enabled
- bit 2        **OC1IE:** Output Compare Channel 1 Interrupt Enable bit  
                  1 = Interrupt request enabled  
                  0 = Interrupt request not enabled
- bit 1        **IC1IE:** Input Capture Channel 1 Interrupt Enable bit  
                  1 = Interrupt request enabled  
                  0 = Interrupt request not enabled
- bit 0        **INT0IE:** External Interrupt 0 Enable bit  
                  1 = Interrupt request enabled  
                  0 = Interrupt request not enabled

# PIC24FJ256GA110 FAMILY

## REGISTER 7-12: IEC1: INTERRUPT ENABLE CONTROL REGISTER 1

R/W-0	R/W-0	R/W-0	R/W-0	R/W-0	R/W-0	R/W-0	U-0
U2TXIE	U2RXIE	INT2IE <sup>(1)</sup>	T5IE	T4IE	OC4IE	OC3IE	—
bit 15							bit 8

R/W-0	R/W-0	U-0	R/W-0	R/W-0	R/W-0	R/W-0	R/W-0
IC8IE	IC7IE	—	INT1IE <sup>(1)</sup>	CNIE	CMIE	MI2C1IE	SI2C1IE
bit 7							bit 0

### Legend:

R = Readable bit	W = Writable bit	U = Unimplemented bit, read as '0'
-n = Value at POR	'1' = Bit is set	'0' = Bit is cleared
		x = Bit is unknown

- bit 15      **U2TXIE:** UART2 Transmitter Interrupt Enable bit  
1 = Interrupt request enabled  
0 = Interrupt request not enabled
- bit 14      **U2RXIE:** UART2 Receiver Interrupt Enable bit  
1 = Interrupt request enabled  
0 = Interrupt request not enabled
- bit 13      **INT2IE:** External Interrupt 2 Enable bit<sup>(1)</sup>  
1 = Interrupt request enabled  
0 = Interrupt request not enabled
- bit 12      **T5IE:** Timer5 Interrupt Enable bit  
1 = Interrupt request enabled  
0 = Interrupt request not enabled
- bit 11      **T4IE:** Timer4 Interrupt Enable bit  
1 = Interrupt request enabled  
0 = Interrupt request not enabled
- bit 10      **OC4IE:** Output Compare Channel 4 Interrupt Enable bit  
1 = Interrupt request enabled  
0 = Interrupt request not enabled
- bit 9        **OC3IE:** Output Compare Channel 3 Interrupt Enable bit  
1 = Interrupt request enabled  
0 = Interrupt request not enabled
- bit 8        **Unimplemented:** Read as '0'
- bit 7        **IC8IE:** Input Capture Channel 8 Interrupt Enable bit  
1 = Interrupt request enabled  
0 = Interrupt request not enabled
- bit 6        **IC7IE:** Input Capture Channel 7 Interrupt Enable bit  
1 = Interrupt request enabled  
0 = Interrupt request not enabled
- bit 5        **Unimplemented:** Read as '0'
- bit 4        **INT1IE:** External Interrupt 1 Enable bit<sup>(1)</sup>  
1 = Interrupt request enabled  
0 = Interrupt request not enabled
- bit 3        **CNIE:** Input Change Notification Interrupt Enable bit  
1 = Interrupt request enabled  
0 = Interrupt request not enabled
- bit 2        **CMIE:** Comparator Interrupt Enable bit  
1 = Interrupt request enabled  
0 = Interrupt request not enabled

**Note 1:** If an external interrupt is enabled, the interrupt input must also be configured to an available RPN or RPI pin. See **Section 10.4 “Peripheral Pin Select (PPS)”** for more information.

# PIC24FJ256GA110 FAMILY

---

## REGISTER 7-12: IEC1: INTERRUPT ENABLE CONTROL REGISTER 1 (CONTINUED)

- bit 1      **MI2C1IE:** Master I2C1 Event Interrupt Enable bit  
            1 = Interrupt request enabled  
            0 = Interrupt request not enabled
- bit 0      **SI2C1IE:** Slave I2C1 Event Interrupt Enable bit  
            1 = Interrupt request enabled  
            0 = Interrupt request not enabled

**Note 1:** If an external interrupt is enabled, the interrupt input must also be configured to an available RPn or RPIn pin. See **Section 10.4 “Peripheral Pin Select (PPS)”** for more information.

# PIC24FJ256GA110 FAMILY

## REGISTER 7-13: IEC2: INTERRUPT ENABLE CONTROL REGISTER 2

U-0	U-0	R/W-0	R/W-0	R/W-0	R/W-0	R/W-0	R/W-0
—	—	PMPIE	OC8IE	OC7IE	OC6IE	OC5IE	IC6IE
bit 15							bit 8

R/W-0	R/W-0	R/W-0	U-0	U-0	U-0	R/W-0	R/W-0
IC5IE	IC4IE	IC3IE	—	—	—	SPI2IE	SPF2IE
bit 7							bit 0

### Legend:

R = Readable bit

W = Writable bit

U = Unimplemented bit, read as '0'

-n = Value at POR

'1' = Bit is set

'0' = Bit is cleared

x = Bit is unknown

- bit 15-14 **Unimplemented:** Read as '0'
- bit 13 **PMPIE:** Parallel Master Port Interrupt Enable bit  
 1 = Interrupt request enabled  
 0 = Interrupt request not enabled
- bit 12 **OC8IE:** Output Compare Channel 8 Interrupt Enable bit  
 1 = Interrupt request enabled  
 0 = Interrupt request not enabled
- bit 11 **OC7IE:** Output Compare Channel 7 Interrupt Enable bit  
 1 = Interrupt request enabled  
 0 = Interrupt request not enabled
- bit 10 **OC6IE:** Output Compare Channel 6 Interrupt Enable bit  
 1 = Interrupt request enabled  
 0 = Interrupt request not enabled
- bit 9 **OC5IE:** Output Compare Channel 5 Interrupt Enable bit  
 1 = Interrupt request enabled  
 0 = Interrupt request not enabled
- bit 8 **IC6IE:** Input Capture Channel 6 Interrupt Enable bit  
 1 = Interrupt request enabled  
 0 = Interrupt request not enabled
- bit 7 **IC5IE:** Input Capture Channel 5 Interrupt Enable bit  
 1 = Interrupt request enabled  
 0 = Interrupt request not enabled
- bit 6 **IC4IE:** Input Capture Channel 4 Interrupt Enable bit  
 1 = Interrupt request enabled  
 0 = Interrupt request not enabled
- bit 5 **IC3IE:** Input Capture Channel 3 Interrupt Enable bit  
 1 = Interrupt request enabled  
 0 = Interrupt request not enabled
- bit 4-2 **Unimplemented:** Read as '0'
- bit 1 **SPI2IE:** SPI2 Event Interrupt Enable bit  
 1 = Interrupt request enabled  
 0 = Interrupt request not enabled
- bit 0 **SPF2IE:** SPI2 Fault Interrupt Enable bit  
 1 = Interrupt request enabled  
 0 = Interrupt request not enabled

# PIC24FJ256GA110 FAMILY

## REGISTER 7-14: IEC3: INTERRUPT ENABLE CONTROL REGISTER 3

U-0	R/W-0	U-0	U-0	U-0	U-0	U-0	U-0
—	RTCIE	—	—	—	—	—	—
bit 15						bit 8	

U-0	R/W-0	R/W-0	U-0	U-0	R/W-0	R/W-0	U-0
—	INT4IE <sup>(1)</sup>	INT3IE <sup>(1)</sup>	—	—	MI2C2IE	SI2C2IE	—
bit 7						bit 0	

### Legend:

R = Readable bit                      W = Writable bit                      U = Unimplemented bit, read as '0'  
 -n = Value at POR                      '1' = Bit is set                      '0' = Bit is cleared                      x = Bit is unknown

- bit 15            **Unimplemented:** Read as '0'
- bit 14            **RTCIE:** Real-Time Clock/Calendar Interrupt Enable bit  
                   1 = Interrupt request enabled  
                   0 = Interrupt request not enabled
- bit 13-7        **Unimplemented:** Read as '0'
- bit 6            **INT4IE:** External Interrupt 4 Enable bit<sup>(1)</sup>  
                   1 = Interrupt request enabled  
                   0 = Interrupt request not enabled
- bit 5            **INT3IE:** External Interrupt 3 Enable bit<sup>(1)</sup>  
                   1 = Interrupt request enabled  
                   0 = Interrupt request not enabled
- bit 4-3         **Unimplemented:** Read as '0'
- bit 2            **MI2C2IE:** Master I2C2 Event Interrupt Enable bit  
                   1 = Interrupt request enabled  
                   0 = Interrupt request not enabled
- bit 1            **SI2C2IE:** Slave I2C2 Event Interrupt Enable bit  
                   1 = Interrupt request enabled  
                   0 = Interrupt request not enabled
- bit 0            **Unimplemented:** Read as '0'

**Note 1:** If an external interrupt is enabled, the interrupt input must also be configured to an available RPn or RPIn pin. See **Section 10.4 “Peripheral Pin Select (PPS)”** for more information.

# PIC24FJ256GA110 FAMILY

## REGISTER 7-15: IEC4: INTERRUPT ENABLE CONTROL REGISTER 4

U-0	U-0	R/W-0	U-0	U-0	U-0	U-0	R/W-0
—	—	CTMUIE	—	—	—	—	LVDIE
bit 15							bit 8

U-0	U-0	U-0	U-0	R/W-0	R/W-0	R/W-0	U-0
—	—	—	—	CRCIE	U2ERIE	U1ERIE	—
bit 7							bit 0

### Legend:

R = Readable bit

W = Writable bit

U = Unimplemented bit, read as '0'

-n = Value at POR

'1' = Bit is set

'0' = Bit is cleared

x = Bit is unknown

- bit 15-14     **Unimplemented:** Read as '0'
- bit 13       **CTMUIE:** CTMU Interrupt Enable bit  
               1 = Interrupt request enabled  
               0 = Interrupt request not enabled
- bit 12-9     **Unimplemented:** Read as '0'
- bit 8         **LVDIE:** Low-Voltage Detect Interrupt Enable bit  
               1 = Interrupt request enabled  
               0 = Interrupt request not enabled
- bit 7-4      **Unimplemented:** Read as '0'
- bit 3         **CRCIE:** CRC Generator Interrupt Enable bit  
               1 = Interrupt request enabled  
               0 = Interrupt request not enabled
- bit 2         **U2ERIE:** UART2 Error Interrupt Enable bit  
               1 = Interrupt request enabled  
               0 = Interrupt request not enabled
- bit 1         **U1ERIE:** UART1 Error Interrupt Enable bit  
               1 = Interrupt request enabled  
               0 = Interrupt request not enabled
- bit 0         **Unimplemented:** Read as '0'

# PIC24FJ256GA110 FAMILY

## REGISTER 7-16: IEC5: INTERRUPT ENABLE CONTROL REGISTER 5

U-0	U-0	R/W-0	R/W-0	R/W-0	R/W-0	R/W-0	R/W-0
—	—	IC9IE	OC9IE	SPI3IE	SPF3IE	U4TXIE	U4RXIE
bit 15						bit 8	

R/W-0	U-0	R/W-0	R/W-0	R/W-0	R/W-0	R/W-0	U-0
U4ERIE	—	MI2C3IE	SI2C3IE	U3TXIE	U3RXIE	U3ERIE	—
bit 7						bit 0	

### Legend:

R = Readable bit                      W = Writable bit                      U = Unimplemented bit, read as '0'  
 -n = Value at POR                      '1' = Bit is set                      '0' = Bit is cleared                      x = Bit is unknown

- bit 15-14    **Unimplemented:** Read as '0'
- bit 13      **IC9IE:** Input Capture Channel 9 Interrupt Enable bit  
                  1 = Interrupt request enabled  
                  0 = Interrupt request not enabled
- bit 12      **OC9IE:** Output Compare Channel 9 Interrupt Enable bit  
                  1 = Interrupt request enabled  
                  0 = Interrupt request not enabled
- bit 11      **SPI3IE:** SPI3 Event Interrupt Enable bit  
                  1 = Interrupt request enabled  
                  0 = Interrupt request not enabled
- bit 10      **SPF3IE:** SPI3 Fault Interrupt Enable bit  
                  1 = Interrupt request enabled  
                  0 = Interrupt request not enabled
- bit 9        **U4TXIE:** UART4 Transmitter Interrupt Enable bit  
                  1 = Interrupt request enabled  
                  0 = Interrupt request not enabled
- bit 8        **U4RXIE:** UART4 Receiver Interrupt Enable bit  
                  1 = Interrupt request enabled  
                  0 = Interrupt request not enabled
- bit 7        **U4ERIE:** UART4 Error Interrupt Enable bit  
                  1 = Interrupt request enabled  
                  0 = Interrupt request not enabled
- bit 6        **Unimplemented:** Read as '0'
- bit 5        **MI2C3IE:** Master I2C3 Event Interrupt Enable bit  
                  1 = Interrupt request enabled  
                  0 = Interrupt request not enabled
- bit 4        **SI2C3IE:** Slave I2C3 Event Interrupt Enable bit  
                  1 = Interrupt request enabled  
                  0 = Interrupt request not enabled
- bit 3        **U3TXIE:** UART3 Transmitter Interrupt Enable bit  
                  1 = Interrupt request enabled  
                  0 = Interrupt request not enabled
- bit 2        **U3RXIE:** UART3 Receiver Interrupt Enable bit  
                  1 = Interrupt request enabled  
                  0 = Interrupt request not enabled
- bit 1        **U3ERIE:** UART3 Error Interrupt Enable bit  
                  1 = Interrupt request enabled  
                  0 = Interrupt request not enabled
- bit 0        **Unimplemented:** Read as '0'

# PIC24FJ256GA110 FAMILY

## REGISTER 7-17: IPC0: INTERRUPT PRIORITY CONTROL REGISTER 0

U-0	R/W-1	R/W-0	R/W-0	U-0	R/W-1	R/W-0	R/W-0
—	T1IP2	T1IP1	T1IP0	—	OC1IP2	OC1IP1	OC1IP0
bit 15						bit 8	

U-0	R/W-1	R/W-0	R/W-0	U-0	R/W-1	R/W-0	R/W-0
—	IC1IP2	IC1IP1	IC1IP0	—	INT0IP2	INT0IP1	INT0IP0
bit 7						bit 0	

### Legend:

R = Readable bit                      W = Writable bit                      U = Unimplemented bit, read as '0'  
 -n = Value at POR                      '1' = Bit is set                      '0' = Bit is cleared                      x = Bit is unknown

- bit 15                      **Unimplemented:** Read as '0'
- bit 14-12                **T1IP[2:0]:** Timer1 Interrupt Priority bits
  - 111 = Interrupt is Priority 7 (highest priority interrupt)
  - 
  - 
  - 
  - 001 = Interrupt is Priority 1
  - 000 = Interrupt source is disabled
- bit 11                      **Unimplemented:** Read as '0'
- bit 10-8                **OC1IP[2:0]:** Output Compare Channel 1 Interrupt Priority bits
  - 111 = Interrupt is Priority 7 (highest priority interrupt)
  - 
  - 
  - 
  - 001 = Interrupt is Priority 1
  - 000 = Interrupt source is disabled
- bit 7                      **Unimplemented:** Read as '0'
- bit 6-4                **IC1IP[2:0]:** Input Capture Channel 1 Interrupt Priority bits
  - 111 = Interrupt is Priority 7 (highest priority interrupt)
  - 
  - 
  - 
  - 001 = Interrupt is Priority 1
  - 000 = Interrupt source is disabled
- bit 3                      **Unimplemented:** Read as '0'
- bit 2-0                **INT0IP[2:0]:** External Interrupt 0 Priority bits
  - 111 = Interrupt is Priority 7 (highest priority interrupt)
  - 
  - 
  - 
  - 001 = Interrupt is Priority 1
  - 000 = Interrupt source is disabled

# PIC24FJ256GA110 FAMILY

## REGISTER 7-18: IPC1: INTERRUPT PRIORITY CONTROL REGISTER 1

U-0	R/W-1	R/W-0	R/W-0	U-0	R/W-1	R/W-0	R/W-0
—	T2IP2	T2IP1	T2IP0	—	OC2IP2	OC2IP1	OC2IP0
bit 15						bit 8	

U-0	R/W-1	R/W-0	R/W-0	U-0	U-0	U-0	U-0
—	IC2IP2	IC2IP1	IC2IP0	—	—	—	—
bit 7						bit 0	

### Legend:

R = Readable bit

W = Writable bit

U = Unimplemented bit, read as '0'

-n = Value at POR

'1' = Bit is set

'0' = Bit is cleared

x = Bit is unknown

- bit 15      **Unimplemented:** Read as '0'
- bit 14-12    **T2IP[2:0]:** Timer2 Interrupt Priority bits  
               111 = Interrupt is Priority 7 (highest priority interrupt)  
               •  
               •  
               •  
               001 = Interrupt is Priority 1  
               000 = Interrupt source is disabled
- bit 11      **Unimplemented:** Read as '0'
- bit 10-8    **OC2IP[2:0]:** Output Compare Channel 2 Interrupt Priority bits  
               111 = Interrupt is Priority 7 (highest priority interrupt)  
               •  
               •  
               •  
               001 = Interrupt is Priority 1  
               000 = Interrupt source is disabled
- bit 7        **Unimplemented:** Read as '0'
- bit 6-4     **IC2IP[2:0]:** Input Capture Channel 2 Interrupt Priority bits  
               111 = Interrupt is Priority 7 (highest priority interrupt)  
               •  
               •  
               •  
               001 = Interrupt is Priority 1  
               000 = Interrupt source is disabled
- bit 3-0     **Unimplemented:** Read as '0'

# PIC24FJ256GA110 FAMILY

## REGISTER 7-19: IPC2: INTERRUPT PRIORITY CONTROL REGISTER 2

U-0	R/W-1	R/W-0	R/W-0	U-0	R/W-1	R/W-0	R/W-0
—	U1RXIP2	U1RXIP1	U1RXIP0	—	SPI1IP2	SPI1IP1	SPI1IP0
bit 15							bit 8

U-0	R/W-1	R/W-0	R/W-0	U-0	R/W-1	R/W-0	R/W-0
—	SPF1IP2	SPF1IP1	SPF1IP0	—	T3IP2	T3IP1	T3IP0
bit 7							bit 0

### Legend:

R = Readable bit                      W = Writable bit                      U = Unimplemented bit, read as '0'  
 -n = Value at POR                      '1' = Bit is set                      '0' = Bit is cleared                      x = Bit is unknown

- bit 15                      **Unimplemented:** Read as '0'
- bit 14-12                **U1RXIP[2:0]:** UART1 Receiver Interrupt Priority bits
  - 111 = Interrupt is Priority 7 (highest priority interrupt)
  - 
  - 
  - 
  - 001 = Interrupt is Priority 1
  - 000 = Interrupt source is disabled
- bit 11                    **Unimplemented:** Read as '0'
- bit 10-8                **SPI1IP[2:0]:** SPI1 Event Interrupt Priority bits
  - 111 = Interrupt is Priority 7 (highest priority interrupt)
  - 
  - 
  - 
  - 001 = Interrupt is Priority 1
  - 000 = Interrupt source is disabled
- bit 7                     **Unimplemented:** Read as '0'
- bit 6-4                 **SPF1IP[2:0]:** SPI1 Fault Interrupt Priority bits
  - 111 = Interrupt is Priority 7 (highest priority interrupt)
  - 
  - 
  - 
  - 001 = Interrupt is Priority 1
  - 000 = Interrupt source is disabled
- bit 3                    **Unimplemented:** Read as '0'
- bit 2-0                 **T3IP[2:0]:** Timer3 Interrupt Priority bits
  - 111 = Interrupt is Priority 7 (highest priority interrupt)
  - 
  - 
  - 
  - 001 = Interrupt is Priority 1
  - 000 = Interrupt source is disabled

# PIC24FJ256GA110 FAMILY

## REGISTER 7-20: IPC3: INTERRUPT PRIORITY CONTROL REGISTER 3

U-0	U-0	U-0	U-0	U-0	U-0	U-0	U-0
—	—	—	—	—	—	—	—
bit 15						bit 8	

U-0	R/W-1	R/W-0	R/W-0	U-0	R/W-1	R/W-0	R/W-0
—	AD1IP2	AD1IP1	AD1IP0	—	U1TXIP2	U1TXIP1	U1TXIP0
bit 7						bit 0	

### Legend:

R = Readable bit                      W = Writable bit                      U = Unimplemented bit, read as '0'  
 -n = Value at POR                      '1' = Bit is set                      '0' = Bit is cleared                      x = Bit is unknown

- bit 15-7        **Unimplemented:** Read as '0'
- bit 6-4        **AD1IP[2:0]:** A/D Conversion Complete Interrupt Priority bits
  - 111 = Interrupt is Priority 7 (highest priority interrupt)
  - 
  - 
  - 
  - 001 = Interrupt is Priority 1
  - 000 = Interrupt source is disabled
- bit 3            **Unimplemented:** Read as '0'
- bit 2-0        **U1TXIP[2:0]:** UART1 Transmitter Interrupt Priority bits
  - 111 = Interrupt is Priority 7 (highest priority interrupt)
  - 
  - 
  - 
  - 001 = Interrupt is Priority 1
  - 000 = Interrupt source is disabled

# PIC24FJ256GA110 FAMILY

## REGISTER 7-21: IPC4: INTERRUPT PRIORITY CONTROL REGISTER 4

U-0	R/W-1	R/W-0	R/W-0	U-0	R/W-1	R/W-0	R/W-0
—	CNIP2	CNIP1	CNIP0	—	CMIP2	CMIP1	CMIP0
bit 15							bit 8

U-0	R/W-1	R/W-0	R/W-0	U-0	R/W-1	R/W-0	R/W-0
—	MI2C1IP2	MI2C1IP1	MI2C1IP0	—	SI2C1IP2	SI2C1IP1	SI2C1IP0
bit 7							bit 0

### Legend:

R = Readable bit                      W = Writable bit                      U = Unimplemented bit, read as '0'  
 -n = Value at POR                      '1' = Bit is set                      '0' = Bit is cleared                      x = Bit is unknown

- bit 15                      **Unimplemented:** Read as '0'
- bit 14-12                **CNIP[2:0]:** Input Change Notification Interrupt Priority bits
  - 111 = Interrupt is Priority 7 (highest priority interrupt)
  - 
  - 
  - 001 = Interrupt is Priority 1
  - 000 = Interrupt source is disabled
- bit 11                      **Unimplemented:** Read as '0'
- bit 10-8                 **CMIP[2:0]:** Comparator Interrupt Priority bits
  - 111 = Interrupt is Priority 7 (highest priority interrupt)
  - 
  - 
  - 001 = Interrupt is Priority 1
  - 000 = Interrupt source is disabled
- bit 7                      **Unimplemented:** Read as '0'
- bit 6-4                    **MI2C1IP[2:0]:** Master I2C1 Event Interrupt Priority bits
  - 111 = Interrupt is Priority 7 (highest priority interrupt)
  - 
  - 
  - 001 = Interrupt is Priority 1
  - 000 = Interrupt source is disabled
- bit 3                      **Unimplemented:** Read as '0'
- bit 2-0                    **SI2C1IP[2:0]:** Slave I2C1 Event Interrupt Priority bits
  - 111 = Interrupt is Priority 7 (highest priority interrupt)
  - 
  - 
  - 001 = Interrupt is Priority 1
  - 000 = Interrupt source is disabled

# PIC24FJ256GA110 FAMILY

## REGISTER 7-22: IPC5: INTERRUPT PRIORITY CONTROL REGISTER 5

U-0	R/W-1	R/W-0	R/W-0	U-0	R/W-1	R/W-0	R/W-0
—	IC8IP2	IC8IP1	IC8IP0	—	IC7IP2	IC7IP1	IC7IP0
bit 15				bit 8			

U-0	U-0	U-0	U-0	U-0	R/W-1	R/W-0	R/W-0
—	—	—	—	—	INT1IP2	INT1IP1	INT1IP0
bit 7				bit 0			

<b>Legend:</b>			
R = Readable bit	W = Writable bit	U = Unimplemented bit, read as '0'	
-n = Value at POR	'1' = Bit is set	'0' = Bit is cleared	x = Bit is unknown

- bit 15        **Unimplemented:** Read as '0'
- bit 14-12    **IC8IP[2:0]:** Input Capture Channel 8 Interrupt Priority bits
  - 111 = Interrupt is Priority 7 (highest priority interrupt)
  - 
  - 
  - 
  - 001 = Interrupt is Priority 1
  - 000 = Interrupt source is disabled
- bit 11        **Unimplemented:** Read as '0'
- bit 10-8     **IC7IP[2:0]:** Input Capture Channel 7 Interrupt Priority bits
  - 111 = Interrupt is Priority 7 (highest priority interrupt)
  - 
  - 
  - 
  - 001 = Interrupt is Priority 1
  - 000 = Interrupt source is disabled
- bit 7-3      **Unimplemented:** Read as '0'
- bit 2-0      **INT1IP[2:0]:** External Interrupt 1 Priority bits
  - 111 = Interrupt is Priority 7 (highest priority interrupt)
  - 
  - 
  - 
  - 001 = Interrupt is Priority 1
  - 000 = Interrupt source is disabled

# PIC24FJ256GA110 FAMILY

## REGISTER 7-23: IPC6: INTERRUPT PRIORITY CONTROL REGISTER 6

U-0	R/W-1	R/W-0	R/W-0	U-0	R/W-1	R/W-0	R/W-0
—	T4IP2	T4IP1	T4IP0	—	OC4IP2	OC4IP1	OC4IP0
bit 15							bit 8

U-0	R/W-1	R/W-0	R/W-0	U-0	U-0	U-0	U-0
—	OC3IP2	OC3IP1	OC3IP0	—	—	—	—
bit 7							bit 0

### Legend:

R = Readable bit

W = Writable bit

U = Unimplemented bit, read as '0'

-n = Value at POR

'1' = Bit is set

'0' = Bit is cleared

x = Bit is unknown

bit 15 **Unimplemented:** Read as '0'

bit 14-12 **T4IP[2:0]:** Timer4 Interrupt Priority bits

111 = Interrupt is Priority 7 (highest priority interrupt)

•  
•  
•

001 = Interrupt is Priority 1

000 = Interrupt source is disabled

bit 11 **Unimplemented:** Read as '0'

bit 10-8 **OC4IP[2:0]:** Output Compare Channel 4 Interrupt Priority bits

111 = Interrupt is Priority 7 (highest priority interrupt)

•  
•  
•

001 = Interrupt is Priority 1

000 = Interrupt source is disabled

bit 7 **Unimplemented:** Read as '0'

bit 6-4 **OC3IP[2:0]:** Output Compare Channel 3 Interrupt Priority bits

111 = Interrupt is Priority 7 (highest priority interrupt)

•  
•  
•

001 = Interrupt is Priority 1

000 = Interrupt source is disabled

bit 3-0 **Unimplemented:** Read as '0'

# PIC24FJ256GA110 FAMILY

## REGISTER 7-24: IPC7: INTERRUPT PRIORITY CONTROL REGISTER 7

U-0	R/W-1	R/W-0	R/W-0	U-0	R/W-1	R/W-0	R/W-0
—	U2TXIP2	U2TXIP1	U2TXIP0	—	U2RXIP2	U2RXIP1	U2RXIP0
bit 15						bit 8	

U-0	R/W-1	R/W-0	R/W-0	U-0	R/W-1	R/W-0	R/W-0
—	INT2IP2	INT2IP1	INT2IP0	—	T5IP2	T5IP1	T5IP0
bit 7						bit 0	

### Legend:

R = Readable bit                      W = Writable bit                      U = Unimplemented bit, read as '0'  
 -n = Value at POR                      '1' = Bit is set                      '0' = Bit is cleared                      x = Bit is unknown

- bit 15                      **Unimplemented:** Read as '0'
- bit 14-12                **U2TXIP[2:0]:** UART2 Transmitter Interrupt Priority bits
  - 111 = Interrupt is Priority 7 (highest priority interrupt)
  - 
  - 
  - 
  - 001 = Interrupt is Priority 1
  - 000 = Interrupt source is disabled
- bit 11                      **Unimplemented:** Read as '0'
- bit 10-8                **U2RXIP[2:0]:** UART2 Receiver Interrupt Priority bits
  - 111 = Interrupt is Priority 7 (highest priority interrupt)
  - 
  - 
  - 
  - 001 = Interrupt is Priority 1
  - 000 = Interrupt source is disabled
- bit 7                      **Unimplemented:** Read as '0'
- bit 6-4                **INT2IP[2:0]:** External Interrupt 2 Priority bits
  - 111 = Interrupt is Priority 7 (highest priority interrupt)
  - 
  - 
  - 
  - 001 = Interrupt is Priority 1
  - 000 = Interrupt source is disabled
- bit 3                      **Unimplemented:** Read as '0'
- bit 2-0                **T5IP[2:0]:** Timer5 Interrupt Priority bits
  - 111 = Interrupt is Priority 7 (highest priority interrupt)
  - 
  - 
  - 
  - 001 = Interrupt is Priority 1
  - 000 = Interrupt source is disabled

# PIC24FJ256GA110 FAMILY

## REGISTER 7-25: IPC8: INTERRUPT PRIORITY CONTROL REGISTER 8

U-0	U-0	U-0	U-0	U-0	U-0	U-0	U-0
—	—	—	—	—	—	—	—
bit 15							bit 8

U-0	R/W-1	R/W-0	R/W-0	U-0	R/W-1	R/W-0	R/W-0
—	SPI2IP2	SPI2IP1	SPI2IP0	—	SPF2IP2	SPF2IP1	SPF2IP0
bit 7							bit 0

### Legend:

R = Readable bit

W = Writable bit

U = Unimplemented bit, read as '0'

-n = Value at POR

'1' = Bit is set

'0' = Bit is cleared

x = Bit is unknown

bit 15-7

**Unimplemented:** Read as '0'

bit 6-4

**SPI2IP[2:0]:** SPI2 Event Interrupt Priority bits

111 = Interrupt is Priority 7 (highest priority interrupt)

•  
•  
•

001 = Interrupt is Priority 1

000 = Interrupt source is disabled

bit 3

**Unimplemented:** Read as '0'

bit 2-0

**SPF2IP[2:0]:** SPI2 Fault Interrupt Priority bits

111 = Interrupt is Priority 7 (highest priority interrupt)

•  
•  
•

001 = Interrupt is Priority 1

000 = Interrupt source is disabled

# PIC24FJ256GA110 FAMILY

## REGISTER 7-26: IPC9: INTERRUPT PRIORITY CONTROL REGISTER 9

U-0	R/W-1	R/W-0	R/W-0	U-0	R/W-1	R/W-0	R/W-0
—	IC5IP2	IC5IP1	IC5IP0	—	IC4IP2	IC4IP1	IC4IP0
bit 15						bit 8	

U-0	R/W-1	R/W-0	R/W-0	U-0	U-0	U-0	U-0
—	IC3IP2	IC3IP1	IC3IP0	—	—	—	—
bit 7						bit 0	

### Legend:

R = Readable bit

W = Writable bit

U = Unimplemented bit, read as '0'

-n = Value at POR

'1' = Bit is set

'0' = Bit is cleared

x = Bit is unknown

- bit 15      **Unimplemented:** Read as '0'
- bit 14-12    **IC5IP[2:0]:** Input Capture Channel 5 Interrupt Priority bits  
               111 = Interrupt is Priority 7 (highest priority interrupt)  
               •  
               •  
               •  
               001 = Interrupt is Priority 1  
               000 = Interrupt source is disabled
- bit 11      **Unimplemented:** Read as '0'
- bit 10-8     **IC4IP[2:0]:** Input Capture Channel 4 Interrupt Priority bits  
               111 = Interrupt is Priority 7 (highest priority interrupt)  
               •  
               •  
               •  
               001 = Interrupt is Priority 1  
               000 = Interrupt source is disabled
- bit 7        **Unimplemented:** Read as '0'
- bit 6-4      **IC3IP[2:0]:** Input Capture Channel 3 Interrupt Priority bits  
               111 = Interrupt is Priority 7 (highest priority interrupt)  
               •  
               •  
               •  
               001 = Interrupt is Priority 1  
               000 = Interrupt source is disabled
- bit 3-0     **Unimplemented:** Read as '0'

# PIC24FJ256GA110 FAMILY

## REGISTER 7-27: IPC10: INTERRUPT PRIORITY CONTROL REGISTER 10

U-0	R/W-1	R/W-0	R/W-0	U-0	R/W-1	R/W-0	R/W-0
—	OC7IP2	OC7IP1	OC7IP0	—	OC6IP2	OC6IP1	OC6IP0
bit 15							bit 8

U-0	R/W-1	R/W-0	R/W-0	U-0	R/W-1	R/W-0	R/W-0
—	OC5IP2	OC5IP1	OC5IP0	—	IC6IP2	IC6IP1	IC6IP0
bit 7							bit 0

### Legend:

R = Readable bit                      W = Writable bit                      U = Unimplemented bit, read as '0'  
 -n = Value at POR                      '1' = Bit is set                      '0' = Bit is cleared                      x = Bit is unknown

- bit 15                      **Unimplemented:** Read as '0'
- bit 14-12                **OC7IP[2:0]:** Output Compare Channel 7 Interrupt Priority bits
  - 111 = Interrupt is Priority 7 (highest priority interrupt)
  - 
  - 
  - 
  - 001 = Interrupt is Priority 1
  - 000 = Interrupt source is disabled
- bit 11                      **Unimplemented:** Read as '0'
- bit 10-8                **OC6IP[2:0]:** Output Compare Channel 6 Interrupt Priority bits
  - 111 = Interrupt is Priority 7 (highest priority interrupt)
  - 
  - 
  - 
  - 001 = Interrupt is Priority 1
  - 000 = Interrupt source is disabled
- bit 7                      **Unimplemented:** Read as '0'
- bit 6-4                **OC5IP[2:0]:** Output Compare Channel 5 Interrupt Priority bits
  - 111 = Interrupt is Priority 7 (highest priority interrupt)
  - 
  - 
  - 
  - 001 = Interrupt is Priority 1
  - 000 = Interrupt source is disabled
- bit 3                      **Unimplemented:** Read as '0'
- bit 2-0                **IC6IP[2:0]:** Input Capture Channel 6 Interrupt Priority bits
  - 111 = Interrupt is Priority 7 (highest priority interrupt)
  - 
  - 
  - 
  - 001 = Interrupt is Priority 1
  - 000 = Interrupt source is disabled

# PIC24FJ256GA110 FAMILY

## REGISTER 7-28: IPC11: INTERRUPT PRIORITY CONTROL REGISTER 11

U-0	U-0	U-0	U-0	U-0	U-0	U-0	U-0
—	—	—	—	—	—	—	—
bit 15						bit 8	

U-0	R/W-1	R/W-0	R/W-0	U-0	R/W-1	R/W-0	R/W-0
—	PMPIP2	PMPIP1	PMPIP0	—	OC8IP2	OC8IP1	OC8IP0
bit 7						bit 0	

### Legend:

R = Readable bit                      W = Writable bit                      U = Unimplemented bit, read as '0'  
 -n = Value at POR                      '1' = Bit is set                      '0' = Bit is cleared                      x = Bit is unknown

- bit 15-7        **Unimplemented:** Read as '0'
- bit 6-4        **PMPIP[2:0]:** Parallel Master Port Interrupt Priority bits
  - 111 = Interrupt is Priority 7 (highest priority interrupt)
  - 
  - 
  - 
  - 001 = Interrupt is Priority 1
  - 000 = Interrupt source is disabled
- bit 3            **Unimplemented:** Read as '0'
- bit 2-0        **OC8IP[2:0]:** Output Compare Channel 8 Interrupt Priority bits
  - 111 = Interrupt is Priority 7 (highest priority interrupt)
  - 
  - 
  - 
  - 001 = Interrupt is Priority 1
  - 000 = Interrupt source is disabled

# PIC24FJ256GA110 FAMILY

## REGISTER 7-29: IPC12: INTERRUPT PRIORITY CONTROL REGISTER 12

U-0	U-0	U-0	U-0	U-0	R/W-1	R/W-0	R/W-0
—	—	—	—	—	MI2C2IP2	MI2C2IP1	MI2C2IP0
bit 15							bit 8

U-0	R/W-1	R/W-0	R/W-0	U-0	U-0	U-0	U-0
—	SI2C2IP2	SI2C2IP1	SI2C2IP0	—	—	—	—
bit 7							bit 0

### Legend:

R = Readable bit

W = Writable bit

U = Unimplemented bit, read as '0'

-n = Value at POR

'1' = Bit is set

'0' = Bit is cleared

x = Bit is unknown

- bit 15-11      **Unimplemented:** Read as '0'
- bit 10-8      **MI2C2IP[2:0]:** Master I2C2 Event Interrupt Priority bits  
                  111 = Interrupt is Priority 7 (highest priority interrupt)  
                  .  
                  .  
                  .  
                  001 = Interrupt is Priority 1  
                  000 = Interrupt source is disabled
- bit 7            **Unimplemented:** Read as '0'
- bit 6-4        **SI2C2IP[2:0]:** Slave I2C2 Event Interrupt Priority bits  
                  111 = Interrupt is Priority 7 (highest priority interrupt)  
                  .  
                  .  
                  .  
                  001 = Interrupt is Priority 1  
                  000 = Interrupt source is disabled
- bit 3-0        **Unimplemented:** Read as '0'

# PIC24FJ256GA110 FAMILY

## REGISTER 7-30: IPC13: INTERRUPT PRIORITY CONTROL REGISTER 13

U-0	U-0	U-0	U-0	U-0	R/W-1	R/W-0	R/W-0
—	—	—	—	—	INT4IP2	INT4IP1	INT4IP0
bit 15						bit 8	

U-0	R/W-1	R/W-0	R/W-0	U-0	U-0	U-0	U-0
—	INT3IP2	INT3IP1	INT3IP0	—	—	—	—
bit 7						bit 0	

### Legend:

R = Readable bit  
-n = Value at POR

W = Writable bit  
'1' = Bit is set

U = Unimplemented bit, read as '0'  
'0' = Bit is cleared  
x = Bit is unknown

- bit 15-11     **Unimplemented:** Read as '0'
- bit 10-8     **INT4IP[2:0]:** External Interrupt 4 Priority bits  
               111 = Interrupt is Priority 7 (highest priority interrupt)  
               •  
               •  
               •  
               001 = Interrupt is Priority 1  
               000 = Interrupt source is disabled
- bit 7         **Unimplemented:** Read as '0'
- bit 6-4     **INT3IP[2:0]:** External Interrupt 3 Priority bits  
               111 = Interrupt is Priority 7 (highest priority interrupt)  
               •  
               •  
               •  
               001 = Interrupt is Priority 1  
               000 = Interrupt source is disabled
- bit 3-0     **Unimplemented:** Read as '0'

# PIC24FJ256GA110 FAMILY

## REGISTER 7-31: IPC15: INTERRUPT PRIORITY CONTROL REGISTER 15

U-0	U-0	U-0	U-0	U-0	R/W-1	R/W-0	R/W-0
—	—	—	—	—	RTCIP2	RTCIP1	RTCIP0
bit 15					bit 8		

U-0	U-0	U-0	U-0	U-0	U-0	U-0	U-0
—	—	—	—	—	—	—	—
bit 7						bit 0	

### Legend:

R = Readable bit                      W = Writable bit                      U = Unimplemented bit, read as '0'  
 -n = Value at POR                      '1' = Bit is set                      '0' = Bit is cleared                      x = Bit is unknown

bit 15-11      **Unimplemented:** Read as '0'  
 bit 10-8      **RTCIP[2:0]:** Real-Time Clock/Calendar Interrupt Priority bits  
                   111 = Interrupt is Priority 7 (highest priority interrupt)  
                   •  
                   •  
                   •  
                   001 = Interrupt is Priority 1  
                   000 = Interrupt source is disabled  
 bit 7-0      **Unimplemented:** Read as '0'

# PIC24FJ256GA110 FAMILY

## REGISTER 7-32: IPC16: INTERRUPT PRIORITY CONTROL REGISTER 16

U-0	R/W-1	R/W-0	R/W-0	U-0	R/W-1	R/W-0	R/W-0
—	CRCIP2	CRCIP1	CRCIP0	—	U2ERIP2	U2ERIP1	U2ERIP0
bit 15							bit 8

U-0	R/W-1	R/W-0	R/W-0	U-0	U-0	U-0	U-0
—	U1ERIP2	U1ERIP1	U1ERIP0	—	—	—	—
bit 7							bit 0

### Legend:

R = Readable bit

W = Writable bit

U = Unimplemented bit, read as '0'

-n = Value at POR

'1' = Bit is set

'0' = Bit is cleared

x = Bit is unknown

bit 15 **Unimplemented:** Read as '0'

bit 14-12 **CRCIP[2:0]:** CRC Generator Error Interrupt Priority bits

111 = Interrupt is Priority 7 (highest priority interrupt)

•

•

•

001 = Interrupt is Priority 1

000 = Interrupt source is disabled

bit 11 **Unimplemented:** Read as '0'

bit 10-8 **U2ERIP[2:0]:** UART2 Error Interrupt Priority bits

111 = Interrupt is Priority 7 (highest priority interrupt)

•

•

•

001 = Interrupt is Priority 1

000 = Interrupt source is disabled

bit 7 **Unimplemented:** Read as '0'

bit 6-4 **U1ERIP[2:0]:** UART1 Error Interrupt Priority bits

111 = Interrupt is Priority 7 (highest priority interrupt)

•

•

•

001 = Interrupt is Priority 1

000 = Interrupt source is disabled

bit 3-0 **Unimplemented:** Read as '0'

# PIC24FJ256GA110 FAMILY

## REGISTER 7-33: IPC18: INTERRUPT PRIORITY CONTROL REGISTER 18

U-0	U-0	U-0	U-0	U-0	U-0	U-0	U-0
—	—	—	—	—	—	—	—
bit 15						bit 8	

U-0	U-0	U-0	U-0	U-0	R/W-1	R/W-0	R/W-0
—	—	—	—	—	LVDIP2	LVDIP1	LVDIP0
bit 7						bit 0	

### Legend:

R = Readable bit                      W = Writable bit                      U = Unimplemented bit, read as '0'  
 -n = Value at POR                      '1' = Bit is set                      '0' = Bit is cleared                      x = Bit is unknown

bit 15-3        **Unimplemented:** Read as '0'  
 bit 2-0        **LVDIP[2:0]:** Low-Voltage Detect Interrupt Priority bits  
                  111 = Interrupt is Priority 7 (highest priority interrupt)  
                  ·  
                  ·  
                  ·  
                  001 = Interrupt is Priority 1  
                  000 = Interrupt source is disabled

## REGISTER 7-34: IPC19: INTERRUPT PRIORITY CONTROL REGISTER 19

U-0	U-0	U-0	U-0	U-0	U-0	U-0	U-0
—	—	—	—	—	—	—	—
bit 15						bit 8	

U-0	R/W-1	R/W-0	R/W-0	U-0	U-0	U-0	U-0
—	CTMUIP2	CTMUIP1	CTMUIP0	—	—	—	—
bit 7						bit 0	

### Legend:

R = Readable bit                      W = Writable bit                      U = Unimplemented bit, read as '0'  
 -n = Value at POR                      '1' = Bit is set                      '0' = Bit is cleared                      x = Bit is unknown

bit 15-7        **Unimplemented:** Read as '0'  
 bit 6-4        **CTMUIP[2:0]:** CTMU Interrupt Priority bits  
                  111 = Interrupt is Priority 7 (highest priority interrupt)  
                  ·  
                  ·  
                  ·  
                  001 = Interrupt is Priority 1  
                  000 = Interrupt source is disabled  
 bit 3-0        **Unimplemented:** Read as '0'

# PIC24FJ256GA110 FAMILY

## REGISTER 7-35: IPC20: INTERRUPT PRIORITY CONTROL REGISTER 20

U-0	R/W-1	R/W-0	R/W-0	U-0	R/W-1	R/W-0	R/W-0
—	U3TXIP2	U3TXIP1	U3TXIP0	—	U3RXIP2	U3RXIP1	U3RXIP0
bit 15							bit 8

U-0	R/W-1	R/W-0	R/W-0	U-0	U-0	U-0	U-0
—	U3ERIP2	U3ERIP1	U3ERIP0	—	—	—	—
bit 7							bit 0

### Legend:

R = Readable bit

W = Writable bit

U = Unimplemented bit, read as '0'

-n = Value at POR

'1' = Bit is set

'0' = Bit is cleared

x = Bit is unknown

- bit 15      **Unimplemented:** Read as '0'
- bit 14-12    **U3TXIP[2:0]:** UART3 Transmitter Interrupt Priority bits  
               111 = Interrupt is Priority 7 (highest priority interrupt)  
               •  
               •  
               •  
               001 = Interrupt is Priority 1  
               000 = Interrupt source is disabled
- bit 11      **Unimplemented:** Read as '0'
- bit 10-8    **U3RXIP[2:0]:** UART3 Receiver Interrupt Priority bits  
               111 = Interrupt is Priority 7 (highest priority interrupt)  
               •  
               •  
               •  
               001 = Interrupt is Priority 1  
               000 = Interrupt source is disabled
- bit 7        **Unimplemented:** Read as '0'
- bit 6-4     **U3ERIP[2:0]:** UART3 Error Interrupt Priority bits  
               111 = Interrupt is Priority 7 (highest priority interrupt)  
               •  
               •  
               •  
               001 = Interrupt is Priority 1  
               000 = Interrupt source is disabled
- bit 3-0     **Unimplemented:** Read as '0'

# PIC24FJ256GA110 FAMILY

## REGISTER 7-36: IPC21: INTERRUPT PRIORITY CONTROL REGISTER 21

U-0	R/W-1	R/W-0	R/W-0	U-0	U-0	U-0	U-0
—	U4ERIP2	U4ERIP1	U4ERIP0	—	—	—	—
bit 15						bit 8	

U-0	R/W-1	R/W-0	R/W-0	U-0	R/W-1	R/W-0	R/W-0
—	MI2C3IP2	MI2C3IP1	MI2C3IP0	—	SI2C3IP2	SI2C3IP1	SI2C3IP0
bit 7						bit 0	

### Legend:

R = Readable bit

W = Writable bit

U = Unimplemented bit, read as '0'

-n = Value at POR

'1' = Bit is set

'0' = Bit is cleared

x = Bit is unknown

- bit 15      **Unimplemented:** Read as '0'
- bit 14-12    **U4ERIP[2:0]:** UART4 Error Interrupt Priority bits  
 111 = Interrupt is Priority 7 (highest priority interrupt)  
 •  
 •  
 •  
 001 = Interrupt is Priority 1  
 000 = Interrupt source is disabled
- bit 11-7    **Unimplemented:** Read as '0'
- bit 6-4      **MI2C3IP[2:0]:** Master I2C3 Event Interrupt Priority bits  
 111 = Interrupt is Priority 7 (highest priority interrupt)  
 •  
 •  
 •  
 001 = Interrupt is Priority 1  
 000 = Interrupt source is disabled
- bit 3        **Unimplemented:** Read as '0'
- bit 2-0      **SI2C3IP[2:0]:** Slave I2C3 Event Interrupt Priority bits  
 111 = Interrupt is Priority 7 (highest priority interrupt)  
 •  
 •  
 •  
 001 = Interrupt is Priority 1  
 000 = Interrupt source is disabled

# PIC24FJ256GA110 FAMILY

## REGISTER 7-37: IPC22: INTERRUPT PRIORITY CONTROL REGISTER 22

U-0	R/W-1	R/W-0	R/W-0	U-0	R/W-1	R/W-0	R/W-0
—	SPI3IP2	SPI3IP1	SPI3IP0	—	SPF3IP2	SPF3IP1	SPF3IP0
bit 15							bit 8

U-0	R/W-1	R/W-0	R/W-0	U-0	R/W-1	R/W-0	R/W-0
—	U4TXIP2	U4TXIP1	U4TXIP0	—	U4RXIP2	U4RXIP1	U4RXIP0
bit 7							bit 0

### Legend:

R = Readable bit                      W = Writable bit                      U = Unimplemented bit, read as '0'  
 -n = Value at POR                      '1' = Bit is set                      '0' = Bit is cleared                      x = Bit is unknown

- bit 15            **Unimplemented:** Read as '0'
- bit 14-12      **SPI3IP[2:0]:** SPI3 Event Interrupt Priority bits
  - 111 = Interrupt is Priority 7 (highest priority interrupt)
  - 
  - 
  - 
  - 001 = Interrupt is Priority 1
  - 000 = Interrupt source is disabled
- bit 11            **Unimplemented:** Read as '0'
- bit 10-8        **SPF3IP[2:0]:** SPI3 Fault Interrupt Priority bits
  - 111 = Interrupt is Priority 7 (highest priority interrupt)
  - 
  - 
  - 
  - 001 = Interrupt is Priority 1
  - 000 = Interrupt source is disabled
- bit 7            **Unimplemented:** Read as '0'
- bit 6-4         **U4TXIP[2:0]:** UART4 Transmitter Interrupt Priority bits
  - 111 = Interrupt is Priority 7 (highest priority interrupt)
  - 
  - 
  - 
  - 001 = Interrupt is Priority 1
  - 000 = Interrupt source is disabled
- bit 3            **Unimplemented:** Read as '0'
- bit 2-0         **U4RXIP[2:0]:** UART4 Receiver Interrupt Priority bits
  - 111 = Interrupt is Priority 7 (highest priority interrupt)
  - 
  - 
  - 
  - 001 = Interrupt is Priority 1
  - 000 = Interrupt source is disabled

# PIC24FJ256GA110 FAMILY

## REGISTER 7-38: IPC23: INTERRUPT PRIORITY CONTROL REGISTER 23

U-0	U-0	U-0	U-0	U-0	U-0	U-0	U-0
—	—	—	—	—	—	—	—
bit 15							bit 8

U-0	R/W-1	R/W-0	R/W-0	U-0	R/W-1	R/W-0	R/W-0
—	IC9IP2	IC9IP1	IC9IP0	—	OC9IP2	OC9IP1	OC9IP0
bit 7							bit 0

### Legend:

R = Readable bit

W = Writable bit

U = Unimplemented bit, read as '0'

-n = Value at POR

'1' = Bit is set

'0' = Bit is cleared

x = Bit is unknown

bit 15-7 **Unimplemented:** Read as '0'

bit 6-4 **IC9IP[2:0]:** Input Capture Channel 9 Interrupt Priority bits

111 = Interrupt is Priority 7 (highest priority interrupt)

•  
•  
•

001 = Interrupt is Priority 1

000 = Interrupt source is disabled

bit 3 **Unimplemented:** Read as '0'

bit 2-0 **OC9IP[2:0]:** Output Compare Channel 9 Interrupt Priority bits

111 = Interrupt is Priority 7 (highest priority interrupt)

•  
•  
•

001 = Interrupt is Priority 1

000 = Interrupt source is disabled

# PIC24FJ256GA110 FAMILY

## REGISTER 7-39: INTTREG: INTERRUPT CONTROL AND STATUS REGISTER

R-0	U-0	R/W-0	U-0	R-0	R-0	R-0	R-0
CPUIRQ	—	VHOLD	—	ILR3	ILR2	ILR1	ILR0
bit 15							bit 8

U-0	R-0	R-0	R-0	R-0	R-0	R-0	R-0
—	VECNUM6	VECNUM5	VECNUM4	VECNUM3	VECNUM2	VECNUM1	VECNUM0
bit 7							bit 0

### Legend:

R = Readable bit                      W = Writable bit                      U = Unimplemented bit, read as '0'  
 -n = Value at POR                      '1' = Bit is set                      '0' = Bit is cleared                      x = Bit is unknown

- bit 15        **CPUIRQ:** Interrupt Request from Interrupt Controller CPU bit  
 1 = An interrupt request has occurred but has not yet been Acknowledged by the CPU; this happens when the CPU priority is higher than the interrupt priority  
 0 = No interrupt request is unacknowledged
- bit 14        Unimplemented: Read as '0'
- bit 13        **VHOLD:** Vector Number Capture Configuration bit  
 1 = VECNUMx bits contain the value of the highest priority pending interrupt  
 0 = VECNUMx bits contain the value of the last Acknowledged interrupt (i.e., the last interrupt that has occurred with higher priority than the CPU, even if other interrupts are pending)
- bit 12        **Unimplemented:** Read as '0'
- bit 11-8      **ILR[3:0]:** New CPU Interrupt Priority Level bits  
 1111 = CPU Interrupt Priority Level is 15  
 •  
 •  
 •  
 0001 = CPU Interrupt Priority Level is 1  
 0000 = CPU Interrupt Priority Level is 0
- bit 7         Unimplemented: Read as '0'
- bit 6-0      **VECNUM[6:0]:** Pending Interrupt Vector ID bits (pending vector number is VECNUMx + 8)  
 01111111 = Interrupt vector pending is number 135  
 •  
 •  
 •  
 00000001 = Interrupt vector pending is number 9  
 00000000 = Interrupt vector pending is number 8

# PIC24FJ256GA110 FAMILY

---

## 7.4 Interrupt Setup Procedures

### 7.4.1 INITIALIZATION

To configure an interrupt source:

1. Set the NSTDIS control bit (INTCON1[15]) if nested interrupts are not desired.
2. Select the user-assigned priority level for the interrupt source by writing the control bits in the appropriate IPCx register. The priority level will depend on the specific application and type of interrupt source. If multiple priority levels are not desired, the IPCx register control bits for all enabled interrupt sources may be programmed to the same non-zero value.

**Note:** At a device Reset, the IPCx registers are initialized, such that all user interrupt sources are assigned to Priority Level 4.

3. Clear the interrupt status flag bit associated with the peripheral in the associated IFSx register.
4. Enable the interrupt source by setting the interrupt enable control bit associated with the source in the appropriate IECx register.

### 7.4.2 INTERRUPT SERVICE ROUTINE

The method that is used to declare an ISR and initialize the IVT with the correct vector address will depend on the programming language (i.e., 'C' or assembler) and the language development toolsuite that is used to develop the application. In general, the user must clear the interrupt flag in the appropriate IFSx register for the source of the interrupt that the ISR handles. Otherwise, the ISR will be re-entered immediately after exiting the routine. If the ISR is coded in assembly language, it must be terminated using a RETFIE instruction to unstack the saved PC value, SRL value and old CPU priority level.

### 7.4.3 TRAP SERVICE ROUTINE

A Trap Service Routine (TSR) is coded like an ISR, except that the appropriate trap status flag in the INTCON1 register must be cleared to avoid re-entry into the TSR.

### 7.4.4 INTERRUPT DISABLE

All user interrupts can be disabled using the following procedure:

1. Push the current SR value onto the software stack using the PUSH instruction.
2. Force the CPU to priority level 7 by inclusive ORing the value E0h with SRL.

To enable user interrupts, the POP instruction may be used to restore the previous SR value.

Note that only user interrupts with a priority level of 7 or less can be disabled. Trap sources (Level 8-15) cannot be disabled.

The DISI instruction provides a convenient way to disable interrupts of Priority Levels 1-6 for a fixed period of time. Level 7 interrupt sources are not disabled by the DISI instruction.

# PIC24FJ256GA110 FAMILY

## 8.0 OSCILLATOR CONFIGURATION

**Note:** This data sheet summarizes the features of this group of PIC24F devices. It is not intended to be a comprehensive reference source. For more information, refer to “Oscillator” ([www.microchip.com/DS39700](http://www.microchip.com/DS39700)) in the “dsPIC33/PIC24 Family Reference Manual”. The information in this data sheet supersedes the information in the FRM.

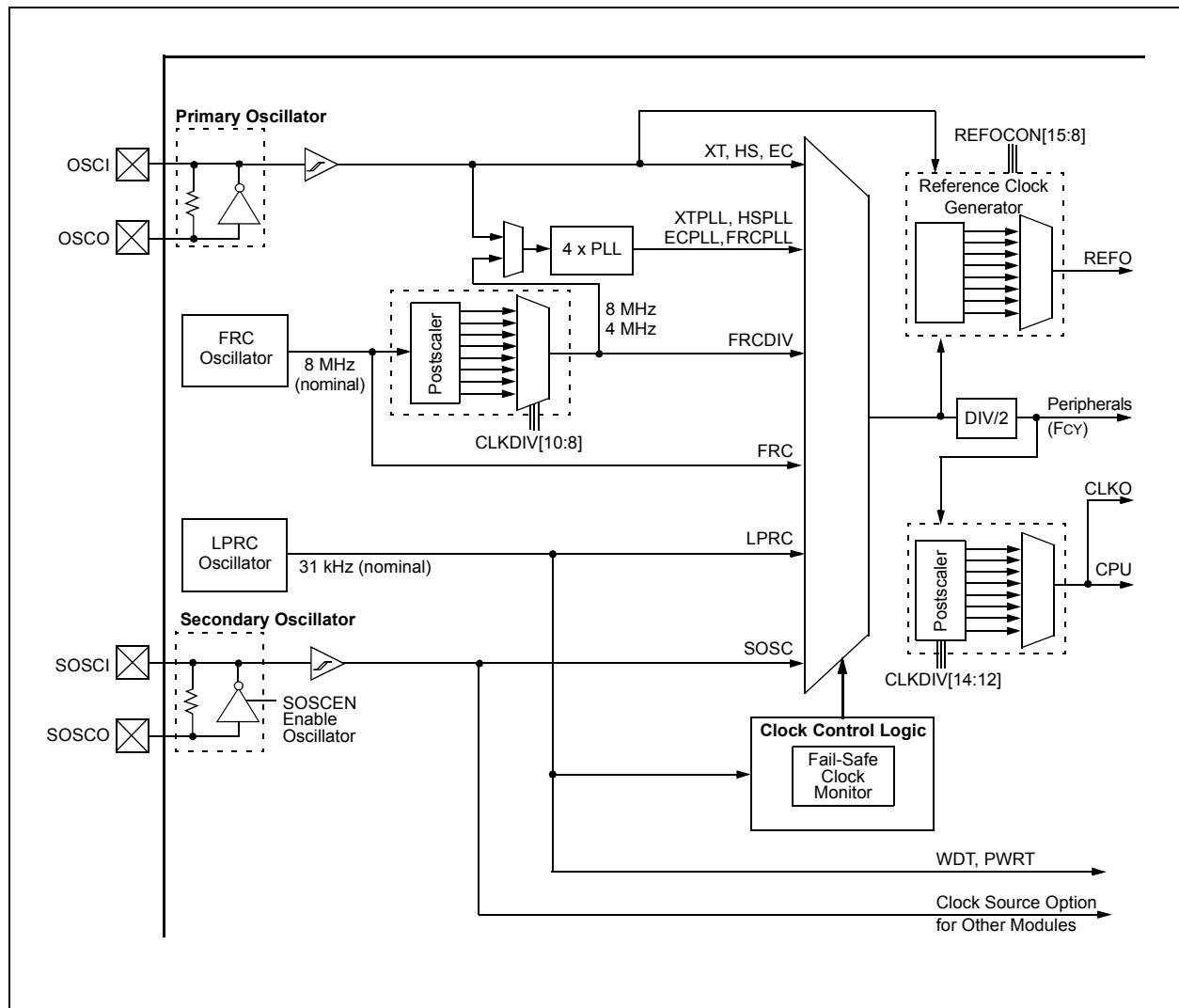
- On-Chip 4x PLL to Boost Internal Operating Frequency on Select Internal and External Oscillator Sources
- Software-Controllable Switching between Various Clock Sources
- Software-Controllable Postscaler for Selective CLOCKING of CPU for System Power Savings
- A Fail-Safe Clock Monitor (FSCM) that Detects Clock Failure and Permits Safe Application Recovery or Shutdown
- A Separate and Independently Configurable System Clock Output for Synchronizing External Hardware

The oscillator system for PIC24FJ256GA110 family devices has the following features:

- A Total of Four External and Internal Oscillator Options as Clock Sources, Providing 11 Different Clock modes

A simplified diagram of the oscillator system is shown in Figure 8-1.

**FIGURE 8-1: PIC24FJ256GA110 FAMILY CLOCK DIAGRAM**



# PIC24FJ256GA110 FAMILY

## 8.1 CPU Clocking Scheme

The system clock source can be provided by one of four sources:

- Primary Oscillator (POSC) on the OSCI and OSCO pins
- Secondary Oscillator (SOSC) on the SOSCI and SOSCO pins
- Fast Internal RC (FRC) Oscillator
- Low-Power Internal RC (LPRC) Oscillator

The Primary Oscillator and FRC sources have the option of using the internal 4x PLL. The frequency of the FRC clock source can optionally be reduced by the programmable clock divider. The selected clock source generates the processor and peripheral clock sources.

The processor clock source is divided by two to produce the internal instruction cycle clock, Fcy. In this document, the instruction cycle clock is also denoted by Fosc/2. The internal instruction cycle clock, Fosc/2, can be provided on the OSCO I/O pin for some operating modes of the Primary Oscillator.

## 8.2 Initial Configuration on POR

The oscillator source (and operating mode) that is used at a device Power-on Reset event is selected using Configuration bit settings. The oscillator Configuration bit settings are located in the Configuration registers in the program memory (refer to [Section 25.1 “Configuration Bits”](#) for further details). The Primary Oscillator Configuration bits, POSCMD[1:0] (Configuration Word 2[1:0]), and the Initial Oscillator Select Configuration bits, FNOSC[2:0] (Configuration Word 2[10:8]), select the oscillator source that is used at a Power-on Reset. The FRC Primary Oscillator with Postscaler (FRCDIV) is the default (unprogrammed) selection. The Secondary Oscillator, or one of the internal oscillators, may be chosen by programming these bit locations.

The Configuration bits allow users to choose between the various clock modes, shown in [Table 8-1](#).

### 8.2.1 CLOCK SWITCHING MODE CONFIGURATION BITS

The FCKSMx Configuration bits (Configuration Word 2[7:6]) are used to jointly configure device clock switching and the Fail-Safe Clock Monitor (FSCM). Clock switching is enabled only when FCKSM1 is programmed ('0'). The FSCM is enabled only when FCKSM[1:0] are both programmed ('00').

**TABLE 8-1: CONFIGURATION BIT VALUES FOR CLOCK SELECTION**

Oscillator Mode	Oscillator Source	POSCMD[1:0]	FNOSC[2:0]	Note
Fast RC Oscillator with Postscaler (FRCDIV)	Internal	11	111	<b>1, 2</b>
(Reserved)	Internal	xx	110	<b>1</b>
Low-Power RC Oscillator (LPRC)	Internal	11	101	<b>1</b>
Secondary (Timer1) Oscillator (SOSC)	Secondary	11	100	<b>1</b>
Primary Oscillator (XT) with PLL Module (XTPLL)	Primary	01	011	
Primary Oscillator (EC) with PLL Module (ECPLL)	Primary	00	011	
Primary Oscillator (HS)	Primary	10	010	
Primary Oscillator (XT)	Primary	01	010	
Primary Oscillator (EC)	Primary	00	010	
Fast RC Oscillator with PLL Module (FRCPLL)	Internal	11	001	<b>1</b>
Fast RC Oscillator (FRC)	Internal	11	000	<b>1</b>

**Note 1:** OSCO pin function is determined by the OSCIOFCN Configuration bit.

**2:** This is the default oscillator mode for an unprogrammed (erased) device.

# PIC24FJ256GA110 FAMILY

## 8.3 Control Registers

The operation of the oscillator is controlled by three Special Function Registers (SFRs):

- OSCCON
- CLKDIV
- OSCTUN

The OSCCON register (Register 8-1) is the main control register for the oscillator. It controls clock source switching and allows the monitoring of clock sources.

The CLKDIV register (Register 8-2) controls the features associated with Doze mode, as well as the postscaler for the FRC Oscillator.

The OSCTUN register (Register 8-3) allows the user to fine tune the FRC Oscillator over a range of approximately  $\pm 12\%$ .

### REGISTER 8-1: OSCCON: OSCILLATOR CONTROL REGISTER

U-0	R-0	R-0	R-0	U-0	R/W-x <sup>(1)</sup>	R/W-x <sup>(1)</sup>	R/W-x <sup>(1)</sup>
—	COSC2	COSC1	COSC0	—	NOSC2	NOSC1	NOSC0
bit 15				bit 8			

R/SO-0	R/W-0	R-0 <sup>(3)</sup>	U-0	R/CO-0	R/W-0	R/W-0	R/W-0
CLKLOCK	IOLOCK <sup>(2)</sup>	LOCK	—	CF	POSCEN	SOSCEN	OSWEN
bit 7				bit 0			

<b>Legend:</b>	CO = Clearable Only bit	SO = Settable Only bit
R = Readable bit	W = Writable bit	U = Unimplemented bit, read as '0'
-n = Value at POR	'1' = Bit is set	'0' = Bit is cleared
		x = Bit is unknown

bit 15 **Unimplemented:** Read as '0'

bit 14-12 **COSC[2:0]:** Current Oscillator Selection bits

- 111 = Fast RC Oscillator with Postscaler (FRCDIV)
- 110 = Reserved
- 101 = Low-Power RC Oscillator (LPRC)
- 100 = Secondary Oscillator (SOSC)
- 011 = Primary Oscillator with PLL module (XTPLL, HSPLL, ECPLL)
- 010 = Primary Oscillator (XT, HS, EC)
- 001 = Fast RC Oscillator with Postscaler and PLL module (FRCPLL)
- 000 = Fast RC Oscillator (FRC)

bit 11 **Unimplemented:** Read as '0'

bit 10-8 **NOSC[2:0]:** New Oscillator Selection bits<sup>(1)</sup>

- 111 = Fast RC Oscillator with Postscaler (FRCDIV)
- 110 = Reserved
- 101 = Low-Power RC Oscillator (LPRC)
- 100 = Secondary Oscillator (SOSC)
- 011 = Primary Oscillator with PLL module (XTPLL, HSPLL, ECPLL)
- 010 = Primary Oscillator (XT, HS, EC)
- 001 = Fast RC Oscillator with Postscaler and PLL module (FRCPLL)
- 000 = Fast RC Oscillator (FRC)

**Note 1:** Reset values for these bits are determined by the FNOSC Configuration bits.

**Note 2:** The state of the IOLOCK bit can only be changed once an unlocking sequence has been executed. In addition, if the IOL1WAY Configuration bit is '1' once the IOLOCK bit is set, it cannot be cleared.

**Note 3:** Also resets to '0' during any valid clock switch or whenever a non-PLL Clock mode is selected.

# PIC24FJ256GA110 FAMILY

---

## REGISTER 8-1: OSCCON: OSCILLATOR CONTROL REGISTER (CONTINUED)

bit 7	<b>CLKLOCK:</b> Clock Selection Lock Enabled bit <u>If FSCM is enabled (FCKSM1 = 1):</u> 1 = Clock and PLL selections are locked 0 = Clock and PLL selections are not locked and may be modified by setting the OSWEN bit <u>If FSCM is disabled (FCKSM1 = 0):</u> Clock and PLL selections are never locked and may be modified by setting the OSWEN bit.
bit 6	<b>IOLOCK:</b> I/O Lock Enable bit <sup>(2)</sup> 1 = I/O lock is active 0 = I/O lock is not active
bit 5	<b>LOCK:</b> PLL Lock Status bit <sup>(3)</sup> 1 = PLL module is in lock or PLL module start-up timer is satisfied 0 = PLL module is out of lock, PLL start-up timer is running or PLL is disabled
bit 4	<b>Unimplemented:</b> Read as '0'
bit 3	<b>CF:</b> Clock Fail Detect bit 1 = FSCM has detected a clock failure 0 = No clock failure has been detected
bit 2	<b>POSCEN:</b> Primary Oscillator Sleep Enable bit 1 = Primary Oscillator continues to operate during Sleep mode 0 = Primary Oscillator disabled during Sleep mode
bit 1	<b>SOSCEN:</b> 32 kHz Secondary Oscillator (SOSC) Enable bit 1 = Enables Secondary Oscillator 0 = Disables Secondary Oscillator
bit 0	<b>OSWEN:</b> Oscillator Switch Enable bit 1 = Initiates an oscillator switch to clock source specified by the NOSC[2:0] bits 0 = Oscillator switch is complete

- Note 1:** Reset values for these bits are determined by the FNOSC Configuration bits.
- 2:** The state of the IOLOCK bit can only be changed once an unlocking sequence has been executed. In addition, if the IOL1WAY Configuration bit is '1' once the IOLOCK bit is set, it cannot be cleared.
- 3:** Also resets to '0' during any valid clock switch or whenever a non-PLL Clock mode is selected.

# PIC24FJ256GA110 FAMILY

## REGISTER 8-2: CLKDIV: CLOCK DIVIDER REGISTER

R/W-0	R/W-0	R/W-0	R/W-0	R/W-0	R/W-0	R/W-0	R/W-1
ROI	DOZE2	DOZE1	DOZE0	DOZEN <sup>(1)</sup>	RCDIV2	RCDIV1	RCDIV0
bit 15							bit 8
U-0	U-0	U-0	U-0	U-0	U-0	U-0	U-0
—	—	—	—	—	—	—	—
bit 7							bit 0

### Legend:

R = Readable bit                      W = Writable bit                      U = Unimplemented bit, read as '0'  
 -n = Value at POR                      '1' = Bit is set                      '0' = Bit is cleared                      x = Bit is unknown

- bit 15            **ROI:** Recover on Interrupt bit  
 1 = Interrupts clear the DOZEN bit and reset the CPU peripheral clock ratio to 1:1  
 0 = Interrupts have no effect on the DOZEN bit
- bit 14-12        **DOZE[2:0]:** CPU Peripheral Clock Ratio Select bits  
 111 = 1:128  
 110 = 1:64  
 101 = 1:32  
 100 = 1:16  
 011 = 1:8  
 010 = 1:4  
 001 = 1:2  
 000 = 1:1
- bit 11            **DOZEN:** Doze Enable bit<sup>(1)</sup>  
 1 = DOZE[2:0] bits specify the CPU peripheral clock ratio  
 0 = CPU peripheral clock ratio is set to 1:1
- bit 10-8        **RCDIV[2:0]:** FRC Postscaler Select bits  
 111 = 31.25 kHz (divide-by-256)  
 110 = 125 kHz (divide-by-64)  
 101 = 250 kHz (divide-by-32)  
 100 = 500 kHz (divide-by-16)  
 011 = 1 MHz (divide-by-8)  
 010 = 2 MHz (divide-by-4)  
 001 = 4 MHz (divide-by-2)  
 000 = 8 MHz (divide-by-1)
- bit 7-0         **Unimplemented:** Read as '0'

**Note 1:** This bit is automatically cleared when the ROI bit is set and an interrupt occurs.

# PIC24FJ256GA110 FAMILY

## REGISTER 8-3: OSCTUN: FRC OSCILLATOR TUNE REGISTER

U-0	U-0	U-0	U-0	U-0	U-0	U-0	U-0
—	—	—	—	—	—	—	—
bit 15							bit 8

U-0	U-0	R/W-0	R/W-0	R/W-0	R/W-0	R/W-0	R/W-0
—	—	TUN[5:0] <sup>(1)</sup>					
bit 7							bit 0

### Legend:

R = Readable bit

W = Writable bit

U = Unimplemented bit, read as '0'

-n = Value at POR

'1' = Bit is set

'0' = Bit is cleared

x = Bit is unknown

bit 15-6

**Unimplemented:** Read as '0'

bit 5-0

**TUN[5:0]:** FRC Oscillator Tuning bits<sup>(1)</sup>

011111 = Maximum frequency deviation

011110 =

•

•

•

000001 =

000000 = Center frequency, oscillator is running at factory calibrated frequency

111111 =

•

•

•

100001 =

100000 = Minimum frequency deviation

**Note 1:** Increments or decrements of TUN[5:0] may not change the FRC frequency in equal steps over the FRC tuning range and may not be monotonic.

## 8.4 Clock Switching Operation

With few limitations, applications are free to switch between any of the four clock sources (POSC, SOS, FRC and LPRC) under software control and at any time. To limit the possible side effects that could result from this flexibility, PIC24F devices have a safeguard lock built into the switching process.

**Note:** The Primary Oscillator mode has three different submodes (XT, HS and EC) which are determined by the POSCMDx Configuration bits. While an application can switch to and from Primary Oscillator mode in software, it cannot switch between the different primary submodes without reprogramming the device.

### 8.4.1 ENABLING CLOCK SWITCHING

To enable clock switching, the FCKSM1 Configuration bit in CW2 must be programmed to '0'. (Refer to [Section 25.1 "Configuration Bits"](#) for further details.) If the FCKSM1 Configuration bit is unprogrammed ('1'), the clock switching function and Fail-Safe Clock Monitor function are disabled; this is the default setting.

The NOSCx control bits (OSCCON[10:8]) do not control the clock selection when clock switching is disabled. However, the COSCx bits (OSCCON[14:12]) will reflect the clock source selected by the FNOSCx Configuration bits.

The OSWEN control bit (OSCCON[0]) has no effect when clock switching is disabled; it is held at '0' at all times.

## 8.4.2 OSCILLATOR SWITCHING SEQUENCE

At a minimum, performing a clock switch requires this basic sequence:

1. If desired, read the COSCx bits (OSCCON[14:12]) to determine the current oscillator source.
2. Perform the unlock sequence to allow a write to the OSCCON register high byte.
3. Write the appropriate value to the NOSCx bits (OSCCON[10:8]) for the new oscillator source.
4. Perform the unlock sequence to allow a write to the OSCCON register low byte.
5. Set the OSWEN bit to initiate the oscillator switch.

Once the basic sequence is completed, the system clock hardware responds automatically as follows:

1. The clock switching hardware compares the COSCx bits with the new value of the NOSCx bits. If they are the same, then the clock switch is a redundant operation. In this case, the OSWEN bit is cleared automatically and the clock switch is aborted.
2. If a valid clock switch has been initiated, the LOCK (OSCCON[5]) and CF (OSCCON[3]) bits are cleared.
3. The new oscillator is turned on by the hardware if it is not currently running. If a crystal oscillator must be turned on, the hardware will wait until the OST expires. If the new source is using the PLL, then the hardware waits until a PLL lock is detected (LOCK = 1).
4. The hardware waits for ten clock cycles from the new clock source and then performs the clock switch.
5. The hardware clears the OSWEN bit to indicate a successful clock transition. In addition, the NOSCx bit values are transferred to the COSCx bits.
6. The old clock source is turned off at this time, with the exception of LPRC (if WDT or FSCM is enabled) or SOSC (if SOSSEN remains set).

**Note 1:** The processor will continue to execute code throughout the clock switching sequence. Timing-sensitive code should not be executed during this time.

- 2: Direct clock switches between any Primary Oscillator mode with PLL and FRCPLL mode are not permitted. This applies to clock switches in either direction. In these instances, the application must switch to FRC mode as a transition clock source between the two PLL modes.

A recommended code sequence for a clock switch includes the following:

1. Disable interrupts during the OSCCON register unlock and write sequence.
2. Execute the unlock sequence for the OSCCON high byte by writing 78h and 9Ah to OSCCON[15:8] in two back-to-back instructions.
3. Write new oscillator source to the NOSCx bits in the instruction immediately following the unlock sequence.
4. Execute the unlock sequence for the OSCCON low byte by writing 46h and 57h to OSCCON[7:0] in two back-to-back instructions.
5. Set the OSWEN bit in the instruction immediately following the unlock sequence.
6. Continue to execute code that is not clock-sensitive (optional).
7. Invoke an appropriate amount of software delay (cycle counting) to allow the selected oscillator and/or PLL to start and stabilize.
8. Check to see if OSWEN is '0'. If it is, the switch was successful. If OSWEN is still set, then check the LOCK bit to determine the cause of failure.

The core sequence for unlocking the OSCCON register and initiating a clock switch is shown in [Example 8-1](#).

### EXAMPLE 8-1: BASIC CODE SEQUENCE FOR CLOCK SWITCHING

```
;Place the new oscillator selection in W0
;OSCCONH (high byte) Unlock Sequence
MOV     #OSCCONH, w1
MOV     #0x78, w2
MOV     #0x9A, w3
MOV.b   w2, [w1]
MOV.b   w3, [w1]
;Set new oscillator selection
MOV.b   WREG, OSCCONH
;OSCCONL (low byte) unlock sequence
MOV     #OSCCONL, w1
MOV     #0x46, w2
MOV     #0x57, w3
MOV.b   w2, [w1]
MOV.b   w3, [w1]
;Start oscillator switch operation
BSET    OSCCON,#0
```

### EXAMPLE 8-2: BASIC CODE SEQUENCE FOR CLOCK SWITCHING

```
//Write new "value" to OSCCONH to
// set the new oscillator selection
__builtin_write_OSCCONH(value);

//Set the OSWEN bit to start the oscillator
// switch operation
__builtin_write_OSCCONL(OSCCON | 0x01);
```

# PIC24FJ256GA110 FAMILY

---

## 8.5 Reference Clock Output

In addition to the CLKO output ( $F_{OSC}/2$ ) available in certain oscillator modes, the device clock in the PIC24FJ256GA110 family devices can also be configured to provide a reference clock output signal to a port pin. This feature is available in all oscillator configurations and allows the user to select a greater range of clock submultiples to drive external devices in the application.

This reference clock output is controlled by the REFOCON register ([Register 8-4](#)). Setting the ROEN bit (REFOCON[15]) makes the clock signal available on the REFO pin. The RODIVx bits (REFOCON[11:8]) enable the selection of 16 different clock divider options.

The ROSSLP and ROSEL bits (REFOCON[13:12]) control the availability of the reference output during Sleep mode. The ROSEL bit determines if the oscillator on OSC1 and OSC2, or the current system clock source, is used for the reference clock output. The ROSSLP bit determines if the reference source is available on REFO when the device is in Sleep mode.

To use the reference clock output in Sleep mode, both the ROSSLP and ROSEL bits must be set. The device clock must also be configured for one of the Primary Oscillator modes (EC, HS or XT); otherwise, if the POSCEN bit is also not set, the oscillator on OSC1 and OSC2 will be powered down when the device enters Sleep mode. Clearing the ROSEL bit allows the reference output frequency to change as the system clock changes during any clock switches.

# PIC24FJ256GA110 FAMILY

## REGISTER 8-4: REFOCON: REFERENCE OSCILLATOR CONTROL REGISTER

R/W-0	U-0	R/W-0	R/W-0	R/W-0	R/W-0	R/W-0	R/W-0
ROEN	—	ROSSLP	ROSEL	RODIV3	RODIV2	RODIV1	RODIV0
bit 15							bit 8
U-0	U-0	U-0	U-0	U-0	U-0	U-0	U-0
—	—	—	—	—	—	—	—
bit 7							bit 0

### Legend:

R = Readable bit                      W = Writable bit                      U = Unimplemented bit, read as '0'  
 -n = Value at POR                      '1' = Bit is set                      '0' = Bit is cleared                      x = Bit is unknown

- bit 15      **ROEN:** Reference Oscillator Output Enable bit  
             1 = Reference oscillator enabled on REFO pin  
             0 = Reference oscillator disabled
- bit 14      **Unimplemented:** Read as '0'
- bit 13      **ROSSLP:** Reference Oscillator Output Stop in Sleep bit  
             1 = Reference oscillator continues to run in Sleep  
             0 = Reference oscillator is disabled in Sleep
- bit 12      **ROSEL:** Reference Oscillator Source Select bit  
             1 = Primary Oscillator used as the base clock. Note that the crystal oscillator must be enabled using the FOSC[2:0] bits; crystal maintains the operation in Sleep mode.  
             0 = System clock used as the base clock; base clock reflects any clock switching of the device
- bit 11-8    **RODIV[3:0]:** Reference Oscillator Divisor Select bits  
             1111 = Base clock value divided by 32,768  
             1110 = Base clock value divided by 16,384  
             1101 = Base clock value divided by 8,192  
             1100 = Base clock value divided by 4,096  
             1011 = Base clock value divided by 2,048  
             1010 = Base clock value divided by 1,024  
             1001 = Base clock value divided by 512  
             1000 = Base clock value divided by 256  
             0111 = Base clock value divided by 128  
             0110 = Base clock value divided by 64  
             0101 = Base clock value divided by 32  
             0100 = Base clock value divided by 16  
             0011 = Base clock value divided by 8  
             0010 = Base clock value divided by 4  
             0001 = Base clock value divided by 2  
             0000 = Base clock value
- bit 7-0     **Unimplemented:** Read as '0'

# PIC24FJ256GA110 FAMILY

---

NOTES:

# PIC24FJ256GA110 FAMILY

## 9.0 POWER-SAVING FEATURES

**Note:** This data sheet summarizes the features of this group of PIC24F devices. It is not intended to be a comprehensive reference source. For more information, refer to “**Power-Saving Features**” ([www.microchip.com/DS39698](http://www.microchip.com/DS39698)) in the “*dsPIC33/PIC24 Family Reference Manual*”. The information in this data sheet supersedes the information in the FRM.

The PIC24FJ256GA110 family of devices provides the ability to manage power consumption by selectively managing clocking to the CPU and the peripherals. In general, a lower clock frequency and a reduction in the number of circuits being clocked constitutes lower consumed power. All PIC24F devices manage power consumption in four different ways:

- Clock Frequency
- Instruction-Based Sleep and Idle modes
- Software Controlled Doze mode
- Selective Peripheral Control in Software

Combinations of these methods can be used to selectively tailor an application’s power consumption, while still maintaining critical application features, such as timing-sensitive communications.

### 9.1 Clock Frequency and Clock Switching

PIC24F devices allow for a wide range of clock frequencies to be selected under application control. If the system clock configuration is not locked, users can choose low-power or high-precision oscillators by simply changing the NOSCx bits. The process of changing a system clock during operation, as well as limitations to the process, are discussed in more detail in [Section 8.0 “Oscillator Configuration”](#).

### 9.2 Instruction-Based Power-Saving Modes

PIC24F devices have two special power-saving modes that are entered through the execution of a special `PWRSVAV` instruction. Sleep mode stops clock operation and halts all code execution; Idle mode halts the CPU

and code execution, but allows peripheral modules to continue operation. The assembly syntax of the `PWRSVAV` instruction is shown in [Example 9-1](#).

Sleep and Idle modes can be exited as a result of an enabled interrupt, WDT time-out or a device Reset. When the device exits these modes, it is said to “wake-up”.

#### 9.2.1 SLEEP MODE

Sleep mode has these features:

- The system clock source is shut down. If an on-chip oscillator is used, it is turned off.
- The device current consumption will be reduced to a minimum provided that no I/O pin is sourcing current.
- The Fail-Safe Clock Monitor does not operate during Sleep mode since the system clock source is disabled.
- The LPRC clock will continue to run in Sleep mode if the WDT is enabled.
- The WDT, if enabled, is automatically cleared prior to entering Sleep mode.
- Some device features or peripherals may continue to operate in Sleep mode. This includes items such as the Input Change Notification (ICN) on the I/O ports, or peripherals that use an external clock input. Any peripheral that requires the system clock source for its operation will be disabled in Sleep mode.

Additional power reductions can be achieved by disabling the on-chip voltage regulator whenever Sleep mode is invoked. This is done by clearing the PMSLP bit (RCON[8]). Disabling the regulator adds an additional delay of about 190  $\mu$ s to the device wake-up time. It is recommended that applications not using the voltage regulator leave the PMSLP bit set. For additional details on the regulator and Sleep mode, see [Section 25.2.5 “Voltage Regulator Standby Mode”](#).

The device will wake-up from Sleep mode on any of these events:

- On any interrupt source that is individually enabled
- On any form of device Reset
- On a WDT time-out

#### EXAMPLE 9-1: `PWRSVAV` INSTRUCTION SYNTAX

```
PWRSVAV    #0                ; Put the device into SLEEP mode
PWRSVAV    #1                ; Put the device into IDLE mode
```

# PIC24FJ256GA110 FAMILY

---

## 9.2.2 IDLE MODE

Idle mode has these features:

- The CPU will stop executing instructions.
- The WDT is automatically cleared.
- The system clock source remains active. By default, all peripheral modules continue to operate normally from the system clock source, but can also be selectively disabled (see [Section 9.4 “Selective Peripheral Module Control”](#)).
- If the WDT or FSCM is enabled, the LPRC will also remain active.

The device will wake from Idle mode on any of these events:

- Any interrupt that is individually enabled
- Any device Reset
- A WDT time-out

On wake-up from Idle, the clock is reapplied to the CPU and instruction execution begins immediately, starting with the instruction following the `PWRSV` instruction or the first instruction in the ISR.

## 9.2.3 INTERRUPTS COINCIDENT WITH POWER SAVE INSTRUCTIONS

Any interrupt that coincides with the execution of a `PWRSV` instruction will be held off until entry into Sleep or Idle mode has completed. The device will then wake-up from Sleep or Idle mode.

## 9.3 Doze Mode

Generally, changing clock speed and invoking one of the power-saving modes are the preferred strategies for reducing power consumption. There may be circumstances, however, where this is not practical. For example, it may be necessary for an application to maintain uninterrupted synchronous communication, even while it is doing nothing else. Reducing system clock speed may introduce communication errors, while using a power-saving mode may stop communications completely.

Doze mode is a simple and effective alternative method to reduce power consumption while the device is still executing code. In this mode, the system clock continues to operate from the same source and at the same speed. Peripheral modules continue to be clocked at the same speed while the CPU clock speed is reduced. Synchronization between the two clock domains is maintained, allowing the peripherals to access the SFRs while the CPU executes code at a slower rate.

Doze mode is enabled by setting the `DOZEN` bit (`CLKDIV[11]`). The ratio between peripheral and core clock speed is determined by the `DOZE[2:0]` bits (`CLKDIV[14:12]`). There are eight possible configurations, from 1:1 to 1:128, with 1:1 being the default.

It is also possible to use Doze mode to selectively reduce power consumption in event driven applications. This allows clock-sensitive functions, such as synchronous communications, to continue without interruption while the CPU Idles, waiting for something to invoke an interrupt routine. Enabling the automatic return to full-speed CPU operation on interrupts is enabled by setting the `ROI` bit (`CLKDIV[15]`). By default, interrupt events have no effect on Doze mode operation.

## 9.4 Selective Peripheral Module Control

Idle and Doze modes allow users to substantially reduce power consumption by slowing or stopping the CPU clock. Even so, peripheral modules still remain clocked and thus consume power. There may be cases where the application needs what these modes do not provide: the allocation of power resources to CPU processing with minimal power consumption from the peripherals.

PIC24F devices address this requirement by allowing peripheral modules to be selectively disabled, reducing or eliminating their power consumption. This can be done with two control bits:

- The Peripheral Enable bit, generically named, “`XXXEN`”, located in the module’s main control SFR.
- The Peripheral Module Disable (PMD) bit, generically named, “`XXXMD`”, located in one of the PMD Control registers.

Both bits have similar functions in enabling or disabling its associated module. Setting the PMD bit for a module disables all clock sources to that module, reducing its power consumption to an absolute minimum. In this state, the control and status registers associated with the peripheral will also be disabled, so writes to those registers will have no effect and read values will be invalid. Many peripheral modules have a corresponding PMD bit.

In contrast, disabling a module by clearing its `XXXEN` bit disables its functionality, but leaves its registers available to be read and written to. This reduces power consumption, but not by as much as setting the PMD bit does. Most peripheral modules have an enable bit; exceptions include input capture, output compare and RTCC.

To achieve more selective power savings, peripheral modules can also be selectively disabled when the device enters Idle mode. This is done through the control bit of the generic name format, “`XXXIDL`”. By default, all modules that can operate during Idle mode will do so. Using the disable on Idle feature allows further reduction of power consumption during Idle mode, enhancing power savings for extremely critical power applications.

# PIC24FJ256GA110 FAMILY

## 10.0 I/O PORTS

**Note:** This data sheet summarizes the features of this group of PIC24F devices. It is not intended to be a comprehensive reference source. For more information, refer to “I/O Ports with Peripheral Pin Select (PPS)” ([www.microchip.com/DS30009711](http://www.microchip.com/DS30009711)) in the “dsPIC33/PIC24 Family Reference Manual”. The information in this data sheet supersedes the information in the FRM.

All of the device pins (except  $V_{DD}$ ,  $V_{SS}$ ,  $\overline{MCLR}$  and  $OSC1/CLK1$ ) are shared between the peripherals and the parallel I/O ports. All I/O input ports feature Schmitt Trigger inputs for improved noise immunity.

### 10.1 Parallel I/O (PIO) Ports

A parallel I/O port that shares a pin with a peripheral is, in general, subservient to the peripheral. The peripheral's output buffer data and control signals are provided to a pair of multiplexers. The multiplexers select whether the peripheral or the associated port has ownership of the output data and control signals of the I/O pin. The logic also prevents “loop through”, in which a port's digital output can drive the input of a peripheral that shares the same pin. Figure 10-1 shows how ports are shared with other peripherals and the associated I/O pin to which they are connected.

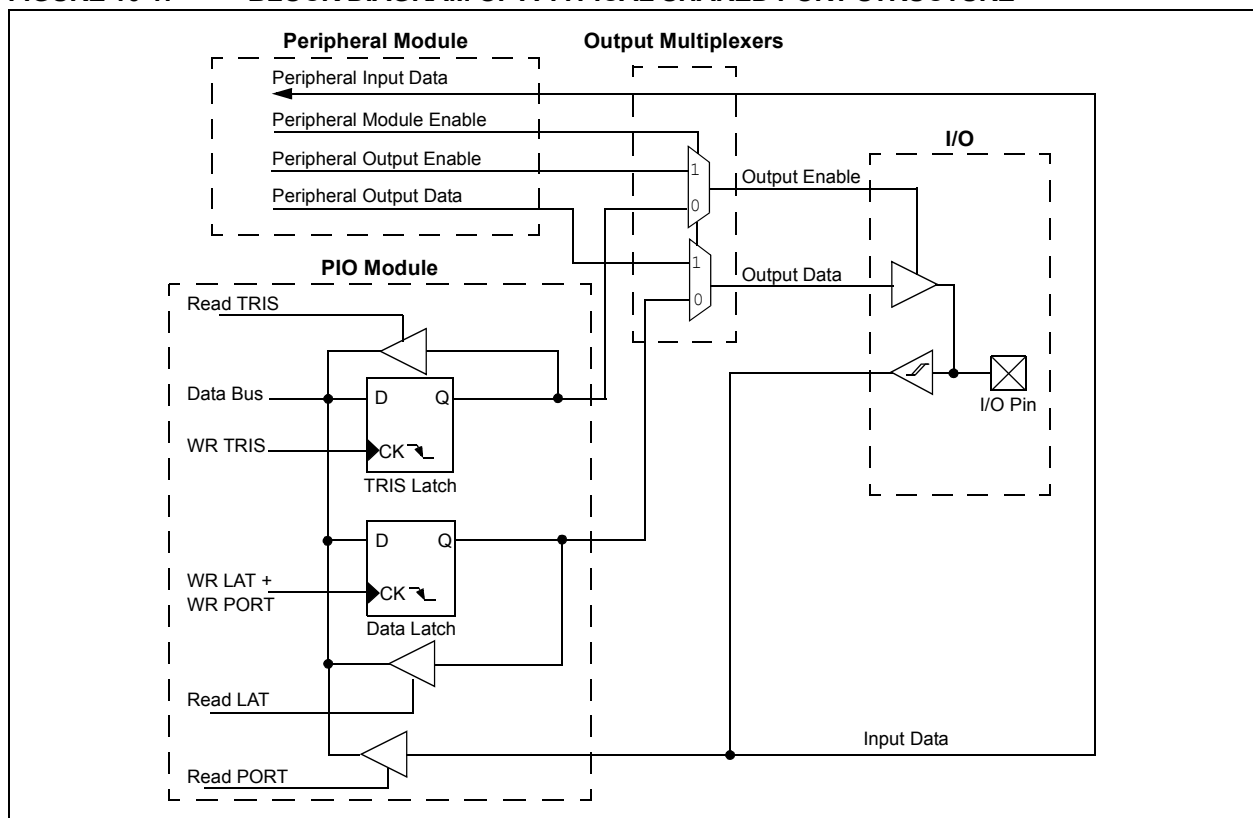
When a peripheral is enabled and the peripheral is actively driving an associated pin, the use of the pin as a general purpose output pin is disabled. The I/O pin may be read, but the output driver for the parallel port bit will be disabled. If a peripheral is enabled, but the peripheral is not actively driving a pin, that pin may be driven by a port.

All port pins have three registers directly associated with their operation as digital I/O. The Data Direction register (TRIS) determines whether the pin is an input or an output. If the data direction bit is a ‘1’, then the pin is an input. All port pins are defined as inputs after a Reset. Reads from the Output Latch register (LAT), read the latch. Writes to the latch, write the latch. Reads from the port (PORT), read the port pins, while writes to the port pins, write the latch.

Any bit and its associated data and control registers that are not valid for a particular device will be disabled. That means the corresponding LAT and TRIS registers and the port pin will read as zeros.

When a pin is shared with another peripheral or function that is defined as an input only, it is regarded as a dedicated port because there is no other competing source of outputs.

**FIGURE 10-1: BLOCK DIAGRAM OF A TYPICAL SHARED PORT STRUCTURE**



# PIC24FJ256GA110 FAMILY

## 10.1.1 OPEN-DRAIN CONFIGURATION

In addition to the PORT, LAT and TRIS registers for data control, each port pin can also be individually configured for either digital or open-drain output. This is controlled by the Open-Drain Control register, ODCx, associated with each port. Setting any of the bits configures the corresponding pin to act as an open-drain output.

The open-drain feature allows the generation of outputs higher than VDD (e.g., 5V) on any desired digital only pins by using external pull-up resistors. The maximum open-drain voltage allowed is the same as the maximum VIH specification.

## 10.2 Configuring Analog Port Pins

The AD1PCFGL and TRIS registers control the operation of the A/D port pins. Setting a port pin as an analog input also requires that the corresponding TRIS bit be set. If the TRIS bit is cleared (output), the digital output level (VOH or VOL) will be converted.

When reading the PORT register, all pins configured as analog input channels will read as cleared (a low level).

Pins configured as digital inputs will not convert an analog input. Analog levels on any pin that is defined as a digital input (including the ANx pins) may cause the input buffer to consume current that exceeds the device specifications.

### 10.2.1 I/O PORT WRITE/READ TIMING

One instruction cycle is required between a port direction change or port write operation and a read operation of the same port. Typically, this instruction would be a NOP.

## 10.2.2 ANALOG INPUT PINS AND VOLTAGE CONSIDERATIONS

The voltage tolerance of pins used as device inputs is dependent on the pin's input function. Pins that are used as digital only inputs are able to handle DC voltages up to 5.5V, a level typical for digital logic circuits. In contrast, pins that also have analog input functions of any kind can only tolerate voltages up to VDD. Voltage excursions beyond VDD on these pins are always to be avoided. Table 10-1 summarizes the input capabilities. Refer to Section 28.1 "DC Characteristics" for more details.

**Note:** For easy identification, the pin diagrams at the beginning of this data sheet also indicate 5.5V tolerant pins with dark grey shading.

TABLE 10-1: INPUT VOLTAGE LEVELS<sup>(1)</sup>

Port or Pin	Tolerated Input	Description
PORTA[10:9]	VDD	Only VDD input levels tolerated.
PORTB[15:0]		
PORTC[15:12]		
PORTD[7:6]		
PORTF[0]		
PORTG[9:6]		
PORTA[15:14], PORTA[7:0]	5.5V	Tolerates input levels above VDD, useful for most standard logic.
PORTC[4:1]		
PORTD[15:8], PORTD[5:0]		
PORTE[9:0]		
PORTF[13:12], PORTF[8:1]		
PORTG[15:12], PORTG[3:0]		

**Note 1:** Not all port pins shown here are implemented on 64-pin and 80-pin devices. Refer to Section 1.0 "Device Overview" to confirm which ports are available in specific devices.

### EXAMPLE 10-1: PORT WRITE/READ EXAMPLE

```
MOV    0xFF00, W0          ; Configure PORTB<15:8> as inputs
MOV    W0, TRISB           ; and PORTB<7:0> as outputs
NOP                    ; Delay 1 cycle
BTSS   PORTB, #13         ; Next Instruction
```

# PIC24FJ256GA110 FAMILY

## 10.3 Input Change Notification

The Input Change Notification (ICN) function of the I/O ports allows the PIC24FJ256GA110 family of devices to generate interrupt requests to the processor in response to a change of state on selected input pins. This feature is capable of detecting input change of states even in Sleep mode, when the clocks are disabled. Depending on the device pin count, there are up to 81 external inputs that may be selected (enabled) for generating an interrupt request on a change of state.

Registers, CNEN1 through CNEN6, contain the interrupt enable control bits for each of the CN input pins. Setting any of these bits enables a CN interrupt for the corresponding pins.

Each CN pin has both a weak pull-up and a weak pull-down connected to it. The pull-up acts as a current source that is connected to the pin, while the pull-down acts as a current sink that is connected to the pin. These eliminate the need for external resistors when push button or keypad devices are connected. The pull-ups and pull-downs are separately enabled using the CNPU1 through CNPU6 registers (for pull-ups) and the CNPD1 through CNPD6 registers (for pull-downs). Each CN pin has individual control bits for its pull-up and pull-down. Setting a control bit enables the weak pull-up or pull-down for the corresponding pin.

When the internal pull-up is selected, the pin pulls up to  $V_{DD} - 0.7V$  (typical). Make certain that there is no external pull-up source when the internal pull-ups are enabled, as the voltage difference can cause a current path.

<b>Note:</b> Pull-ups on Change Notification (CN) pins should always be disabled whenever the port pin is configured as a digital output.
---

## 10.4 Peripheral Pin Select (PPS)

A major challenge in general purpose devices is providing the largest possible set of peripheral features while minimizing the conflict of features on I/O pins. In an application that needs to use more than one peripheral multiplexed on a single pin, inconvenient work arounds in application code or a complete redesign may be the only option.

The Peripheral Pin Select feature provides an alternative to these choices by enabling the user's peripheral set selection and their placement on a wide range of I/O pins. By increasing the pinout options available on a particular device, users can better tailor the microcontroller to their entire application, rather than trimming the application to fit the device.

The Peripheral Pin Select feature operates over a fixed subset of digital I/O pins. Users may independently map the input and/or output of any one of many digital peripherals to any one of these I/O pins. Peripheral Pin Select is performed in software and generally does not require the device to be reprogrammed. Hardware safeguards are included that prevent accidental or spurious changes to the peripheral mapping once it has been established.

### 10.4.1 AVAILABLE PINS

The Peripheral Pin Select feature is used with a range of up to 46 pins, depending on the particular device and its pin count. Pins that support the Peripheral Pin Select feature include the designation "RPn" or "RPI n" in their full pin designation, where "n" is the remappable pin number. "RP" is used to designate pins that support both remappable input and output functions, while "RPI" indicates pins that support remappable input functions only.

In this device family, there are up to 32 remappable input/output pins, depending on the pin count of the particular device selected; these are numbered, RP0 through RP31. Remappable input only pins are numbered above this range, from RPI32 to RPI45 (or the upper limit for that particular device).

See [Table 1-4](#) for a summary of pinout options in each package offering.

# PIC24FJ256GA110 FAMILY

---

## 10.4.2 AVAILABLE PERIPHERALS

The peripherals managed by the Peripheral Pin Select are all digital only peripherals. These include general serial communications (UART and SPI), general purpose timer clock inputs, timer related peripherals (input capture and output compare) and external interrupt inputs. Also included are the outputs of the comparator module, since these are discrete digital signals.

Peripheral Pin Select is not available for I<sup>2</sup>C, Change Notification inputs, RTCC alarm outputs or peripherals with analog inputs.

A key difference between pin select and non pin select peripherals is that pin select peripherals are not associated with a default I/O pin. The peripheral must always be assigned to a specific I/O pin before it can be used. In contrast, non pin select peripherals are always available on a default pin, assuming that the peripheral is active and not conflicting with another peripheral.

### 10.4.2.1 Peripheral Pin Select Function Priority

Pin-selectable peripheral outputs (e.g. OC, UART Transmit) take priority over general purpose digital functions on a pin, such as PMP and port I/O. Specialized digital outputs, such as USB functionality, will take priority over PPS outputs on the same pin. The pin diagrams provided at the beginning of this data sheet list peripheral outputs in order of priority. Refer to them for priority concerns on a particular pin.

Unlike PIC24F devices with fixed peripherals, pin-selectable peripheral inputs never take ownership of a pin. The pin's output buffer is controlled by the TRISx setting or by a fixed peripheral on the pin. If the pin is configured in Digital mode, the PPS input will operate correctly. If an analog function is enabled on the pin, the PPS input will be disabled.

## 10.4.3 CONTROLLING PERIPHERAL PIN SELECT

Peripheral Pin Select features are controlled through two sets of Special Function Registers: one to map peripheral inputs and one to map outputs. Because they are separately controlled, a particular peripheral's input and output (if the peripheral has both) can be placed on any selectable function pin without constraint.

The association of a peripheral to a peripheral-selectable pin is handled in two different ways, depending on if an input or an output is being mapped.

### 10.4.3.1 Input Mapping

The inputs of the Peripheral Pin Select options are mapped on the basis of the peripheral; that is, a control register associated with a peripheral dictates the pin it will be mapped to. The RPINRx registers are used to configure peripheral input mapping (see [Register 10-1](#) through [Register 10-21](#)). Each register contains two sets of 6-bit fields, with each set associated with one of the pin-selectable peripherals. Programming a given peripheral's bit field with an appropriate 6-bit value maps the RPn pin with that value to that peripheral. For any given device, the valid range of values for any of the bit fields corresponds to the maximum number of Peripheral Pin Select options supported by the device.

### 10.4.3.2 Output Mapping

In contrast to inputs, the outputs of the Peripheral Pin Select options are mapped on the basis of the pin. In this case, a control register associated with a particular pin dictates the peripheral output to be mapped. The RPORx registers are used to control output mapping. Each register contains two 6-bit fields, with each field being associated with one RPn pin (see [Register 10-22](#) through [Register 10-37](#)). The value of the bit field corresponds to one of the peripherals and that peripheral's output is mapped to the pin (see [Table 10-3](#)).

Because of the mapping technique, the list of peripherals for output mapping also includes a null value of '000000'. This permits any given pin to remain disconnected from the output of any of the pin-selectable peripherals.

### 10.4.3.3 Alternate Fixed Pin Mapping

To provide a migration option from earlier high pin count PIC24F devices, PIC24FJ256GA110 family devices implement an additional option for mapping the clock output (SCK) of SPI1. This option permits users to map SCK1OUT specifically to the fixed pin function, ASCK1. The SCK1CM bit (ALTRP[0]) controls this mapping; setting the bit maps SCK1OUT to ASCK1.

The SCK1CM bit must be set (= 1) before enabling the SPI module. It must remain set while transactions using SPI1 are in progress, in order to prevent transmission errors; when the module is disabled, the bit must be cleared. Additionally, no other RPOUT register should be configured to output the SCK1OUT function while SCK1CM is set.

# PIC24FJ256GA110 FAMILY

**TABLE 10-2: SELECTABLE INPUT SOURCES (MAPS INPUT TO FUNCTION)<sup>(1)</sup>**

Input Name	Function Name	Register	Function Mapping Bits
External Interrupt 1	INT1	RPINR0	INT1R[5:0]
External Interrupt 2	INT2	RPINR1	INT2R[5:0]
External Interrupt 3	INT3	RPINR1	INT3R[5:0]
External Interrupt 4	INT4	RPINR2	INT4R[5:0]
Input Capture 1	IC1	RPINR7	IC1R[5:0]
Input Capture 2	IC2	RPINR7	IC2R[5:0]
Input Capture 3	IC3	RPINR8	IC3R[5:0]
Input Capture 4	IC4	RPINR8	IC4R[5:0]
Input Capture 5	IC5	RPINR9	IC5R[5:0]
Input Capture 6	IC6	RPINR9	IC6R[5:0]
Input Capture 7	IC7	RPINR10	IC7R[5:0]
Input Capture 8	IC8	RPINR10	IC8R[5:0]
Input Capture 9	IC9	RPINR15	IC9R[5:0]
Output Compare Fault A	OCFA	RPINR11	OCFAR[5:0]
Output Compare Fault B	OCFB	RPINR11	OCFBR[5:0]
SPI1 Clock Input	SCK1IN	RPINR20	SCK1R[5:0]
SPI1 Data Input	SDI1	RPINR20	SDI1R[5:0]
SPI1 Slave Select Input	SS1IN	RPINR21	SS1R[5:0]
SPI2 Clock Input	SCK2IN	RPINR22	SCK2R[5:0]
SPI2 Data Input	SDI2	RPINR22	SDI2R[5:0]
SPI2 Slave Select Input	SS2IN	RPINR23	SS2R[5:0]
SPI3 Clock Input	SCK3IN	RPINR28	SCK3R[5:0]
SPI3 Data Input	SDI3	RPINR28	SDI3R[5:0]
SPI3 Slave Select Input	SS3IN	RPINR29	SS3R[5:0]
Timer2 External Clock	T2CK	RPINR3	T2CKR[5:0]
Timer3 External Clock	T3CK	RPINR3	T3CKR[5:0]
Timer4 External Clock	T4CK	RPINR4	T4CKR[5:0]
Timer5 External Clock	T5CK	RPINR4	T5CKR[5:0]
UART1 Clear-to-Send	$\overline{U1CTS}$	RPINR18	U1CTSR[5:0]
UART1 Receive	U1RX	RPINR18	U1RXR[5:0]
UART2 Clear-to-Send	$\overline{U2CTS}$	RPINR19	U2CTSR[5:0]
UART2 Receive	U2RX	RPINR19	U2RXR[5:0]
UART3 Clear-to-Send	$\overline{U3CTS}$	RPINR21	U3CTSR[5:0]
UART3 Receive	U3RX	RPINR17	U3RXR[5:0]
UART4 Clear-to-Send	$\overline{U4CTS}$	RPINR27	U4CTSR[5:0]
UART4 Receive	U4RX	RPINR27	U4RXR[5:0]

**Note 1:** Unless otherwise noted, all inputs use the Schmitt Trigger input buffers.

# PIC24FJ256GA110 FAMILY

**TABLE 10-3: SELECTABLE OUTPUT SOURCES (MAPS FUNCTION TO OUTPUT)**

Output Function Number <sup>(1)</sup>	Function	Output Name
0	NULL <sup>(2)</sup>	Null
1	C1OUT	Comparator 1 Output
2	C2OUT	Comparator 2 Output
3	U1TX	UART1 Transmit
4	$\overline{\text{U1RTS}}$ <sup>(3)</sup>	UART1 Request-to-Send
5	U2TX	UART2 Transmit
6	$\overline{\text{U2RTS}}$ <sup>(3)</sup>	UART2 Request-to-Send
7	SDO1	SPI1 Data Output
8	SCK1OUT <sup>(4)</sup>	SPI1 Clock Output
9	SS1OUT	SPI1 Slave Select Output
10	SDO2	SPI2 Data Output
11	SCK2OUT	SPI2 Clock Output
12	SS2OUT	SPI2 Slave Select Output
18	OC1	Output Compare 1
19	OC2	Output Compare 2
20	OC3	Output Compare 3
21	OC4	Output Compare 4
22	OC5	Output Compare 5
23	OC6	Output Compare 6
24	OC7	Output Compare 7
25	OC8	Output Compare 8
28	U3TX	UART3 Transmit
29	$\overline{\text{U3RTS}}$ <sup>(3)</sup>	UART3 Request-to-Send
30	U4TX	UART4 Transmit
31	$\overline{\text{U4RTS}}$ <sup>(3)</sup>	UART4 Request-to-Send
32	SDO3	SPI3 Data Output
33	SCK3OUT	SPI3 Clock Output
34	SS3OUT	SPI3 Slave Select Output
35	OC9	Output Compare 9
36	C3OUT	Comparator 3 Output
37-63	(unused)	NC

- Note 1:** Setting the RPORx register with the listed value assigns that output function to the associated RPn pin.
- Note 2:** The NULL function is assigned to all RPn outputs at device Reset and disables the RPn output function.
- Note 3:** IrDA<sup>®</sup> BCLK functionality uses this output.
- Note 4:** SCK1OUT can also be specifically mapped to the ASCK1 pin by setting the SCK1CM bit (ALTRP[0]). See [Section 10.4.3.3 “Alternate Fixed Pin Mapping”](#) for more information.

# PIC24FJ256GA110 FAMILY

## 10.4.3.4 Mapping Limitations

The control schema of the Peripheral Pin Select is extremely flexible. Other than systematic blocks that prevent signal contention caused by two physical pins being configured as the same functional input or two functional outputs configured as the same pin, there are no hardware enforced lock outs. The flexibility extends to the point of allowing a single input to drive multiple peripherals or a single functional output to drive multiple output pins.

## 10.4.3.5 Mapping Exceptions for PIC24FJ256GA110 Family Devices

Although the PPS registers theoretically allow for up to 64 remappable I/O pins, not all of these are implemented in all devices. For PIC24FJ256GA110 family devices, the maximum number of remappable pins available are 46, which includes 14 input only pins. In addition, some pins in the RPn and RPI n sequences are unimplemented in lower pin count devices. The differences in available remappable pins are summarized in [Table 10-4](#).

When developing applications that use remappable pins, users should also keep these things in mind:

- For the RPINRx registers, bit combinations corresponding to an unimplemented pin for a particular device are treated as invalid; the corresponding module will not have an input mapped to it. For all PIC24FJ256GA110 family devices, this includes all values greater than 45 ('101101').
- For RPORx registers, the bit fields corresponding to an unimplemented pin will also be unimplemented. Writing to these fields will have no effect.

## 10.4.4 CONTROLLING CONFIGURATION CHANGES

Because peripheral remapping can be changed during run time, some restrictions on peripheral remapping are needed to prevent accidental configuration changes. PIC24F devices include three features to prevent alterations to the peripheral map:

- Control register lock sequence
- Continuous state monitoring
- Configuration bit remapping lock

## 10.4.4.1 Control Register Lock

Under normal operation, writes to the RPINRx and RPORx registers are not allowed. Attempted writes will appear to execute normally, but the contents of the registers will remain unchanged. To change these registers, they must be unlocked in hardware. The register lock is controlled by the IOLOCK bit (OSCCON[6]). Setting IOLOCK prevents writes to the control registers; clearing IOLOCK allows writes.

To set or clear IOLOCK, a specific command sequence must be executed:

1. Write 46h to OSCCON[7:0].
2. Write 57h to OSCCON[7:0].
3. Clear (or set) IOLOCK as a single operation.

Unlike the similar sequence with the oscillator's LOCK bit, IOLOCK remains in one state until changed. This allows all of the Peripheral Pin Selects to be configured with a single unlock sequence, followed by an update to all control registers, then locked with a second lock sequence.

## 10.4.4.2 Continuous State Monitoring

In addition to being protected from direct writes, the contents of the RPINRx and RPORx registers are constantly monitored in hardware by shadow registers. If an unexpected change in any of the registers occurs (such as cell disturbances caused by ESD or other external events), a Configuration Mismatch Reset will be triggered.

## 10.4.4.3 Configuration Bit Pin Select Lock

As an additional level of safety, the device can be configured to prevent more than one write session to the RPINRx and RPORx registers. The IOL1WAY (CW2[4]) Configuration bit blocks the IOLOCK bit from being cleared after it has been set once. If IOLOCK remains set, the register unlock procedure will not execute and the Peripheral Pin Select Control registers cannot be written to. The only way to clear the bit and re-enable peripheral remapping is to perform a device Reset.

In the default (unprogrammed) state, IOL1WAY is set, restricting users to one write session. Programming IOL1WAY allows users unlimited access (with the proper use of the unlock sequence) to the Peripheral Pin Select registers.

**TABLE 10-4: REMAPPABLE PIN EXCEPTIONS FOR PIC24FJ256GA110 FAMILY DEVICES**

Device Pin Count	RP Pins (I/O)		RPI Pins	
	Total	Unimplemented	Total	Unimplemented
64-pin	29	RP5, RP15, RP31	2	RPI32-36, RPI38-44
80-pin	31	RP31	11	RPI32, RPI39, RPI41
100-pin	32	—	14	—

# PIC24FJ256GA110 FAMILY

## 10.4.5 CONSIDERATIONS FOR PERIPHERAL PIN SELECTION

The ability to control Peripheral Pin Select options introduces several considerations into application design that could be overlooked. This is particularly true for several common peripherals that are available only as remappable peripherals.

The main consideration is that the Peripheral Pin Selects are not available on default pins in the device's default (Reset) state. Since all RPINRx registers reset to '111111' and all RPORx registers reset to '000000', all Peripheral Pin Select inputs are tied to Vss and all Peripheral Pin Select outputs are disconnected.

**Note:** In tying Peripheral Pin Select inputs to RP63, RP63 does not have to exist on a device for the registers to be reset to it.

This situation requires the user to initialize the device with the proper peripheral configuration before any other application code is executed. Since the IOLOCK bit resets in the unlocked state, it is not necessary to execute the unlock sequence after the device has come out of Reset. For application safety, however, it is best to set IOLOCK and lock the configuration after writing to the control registers.

Because the unlock sequence is timing critical, it must be executed as an assembly language routine in the same manner as changes to the oscillator configuration. If the bulk of the application is written in C or another high-level language, the unlock sequence should be performed by writing in-line assembly.

Choosing the configuration requires the review of all Peripheral Pin Selects and their pin assignments, especially those that will not be used in the application. In all cases, unused pin-selectable peripherals should be disabled completely. Unused peripherals should have their inputs assigned to an unused RPn pin function. I/O pins with unused RPn functions should be configured with the null peripheral output.

The assignment of a peripheral to a particular pin does not automatically perform any other configuration of the pin's I/O circuitry. In theory, this means adding a pin-selectable output to a pin may mean inadvertently driving an existing peripheral input when the output is driven. Users must be familiar with the behavior of other fixed peripherals that share a remappable pin and know when to enable or disable them. To be safe, fixed digital peripherals that share the same pin should be disabled when not in use.

Along these lines, configuring a remappable pin for a specific peripheral does not automatically turn that feature on. The peripheral must be specifically configured for operation and enabled, as if it were tied to a fixed pin. Where this happens in the application code (immediately following device Reset and peripheral configuration or inside the main application routine) depends on the peripheral and its use in the application.

A final consideration is that Peripheral Pin Select functions neither override analog inputs, nor reconfigure pins with analog functions for digital I/Os. If a pin is configured as an analog input on device Reset, it must be explicitly reconfigured as a digital I/O when used with a Peripheral Pin Select.

**Example 10-2** shows a configuration for bidirectional communication with flow control using UART1. The following input and output functions are used:

- Input Functions: U1RX,  $\overline{U1CTS}$
- Output Functions: U1TX,  $\overline{U1RTS}$

### EXAMPLE 10-2: CONFIGURING UART1 INPUT AND OUTPUT FUNCTIONS

```
// Unlock Registers
__builtin_write_OSCCONL(OSCCON & 0xBF);

// Configure Input Functions (Table 9-1)
// Assign U1RX To Pin RP0
RPINR18bits.U1RXR = 0;

// Assign U1CTS To Pin RP1
RPINR18bits.U1CTSR = 1;

// Configure Output Functions (Table 9-2)
// Assign U1TX To Pin RP2
RPOR1bits.RP2R = 3;

// Assign U1RTS To Pin RP3
RPOR1bits.RP3R = 4;

// Lock Registers
__builtin_write_OSCCONL(OSCCON | 0x40);
```

# PIC24FJ256GA110 FAMILY

## 10.4.6 PERIPHERAL PIN SELECT REGISTERS

The PIC24FJ256GA110 family of devices implements a total of 37 registers for remappable peripheral configuration:

- Input Remappable Peripheral Registers (21)
- Output Remappable Peripheral Registers (16)

**Note:** Input and output register values can only be changed if IOLOCK (OSCCON[6]) = 0. See [Section 10.4.4.1 “Control Register Lock”](#) for a specific command sequence.

### REGISTER 10-1: RPINR0: PERIPHERAL PIN SELECT INPUT REGISTER 0

U-0	U-0	R/W-1	R/W-1	R/W-1	R/W-1	R/W-1	R/W-1
—	—	INT1R5	INT1R4	INT1R3	INT1R2	INT1R1	INT1R0
bit 15							bit 8

U-0	U-0	U-0	U-0	U-0	U-0	U-0	U-0
—	—	—	—	—	—	—	—
bit 7							bit 0

**Legend:**

R = Readable bit                      W = Writable bit                      U = Unimplemented bit, read as '0'  
 -n = Value at POR                      '1' = Bit is set                      '0' = Bit is cleared                      x = Bit is unknown

- bit 15-14    **Unimplemented:** Read as '0'
- bit 13-8    **INT1R[5:0]:** Assign External Interrupt 1 (INT1) to Corresponding RPN or RPN Pin bits
- bit 7-0     **Unimplemented:** Read as '0'

### REGISTER 10-2: RPINR1: PERIPHERAL PIN SELECT INPUT REGISTER 1

U-0	U-0	R/W-1	R/W-1	R/W-1	R/W-1	R/W-1	R/W-1
—	—	INT3R5	INT3R4	INT3R3	INT3R2	INT3R1	INT3R0
bit 15							bit 8

U-0	U-0	R/W-1	R/W-1	R/W-1	R/W-1	R/W-1	R/W-1
—	—	INT2R5	INT2R4	INT2R3	INT2R2	INT2R1	INT2R0
bit 7							bit 0

**Legend:**

R = Readable bit                      W = Writable bit                      U = Unimplemented bit, read as '0'  
 -n = Value at POR                      '1' = Bit is set                      '0' = Bit is cleared                      x = Bit is unknown

- bit 15-14    **Unimplemented:** Read as '0'
- bit 13-8    **INT3R[5:0]:** Assign External Interrupt 3 (INT3) to Corresponding RPN or RPN Pin bits
- bit 7-6     **Unimplemented:** Read as '0'
- bit 5-0     **INT2R[5:0]:** Assign External Interrupt 2 (INT2) to Corresponding RPN or RPN Pin bits

# PIC24FJ256GA110 FAMILY

## REGISTER 10-3: RPINR2: PERIPHERAL PIN SELECT INPUT REGISTER 2

U-0	U-0	U-0	U-0	U-0	U-0	U-0	U-0
—	—	—	—	—	—	—	—
bit 15							bit 8

U-0	U-0	R/W-1	R/W-1	R/W-1	R/W-1	R/W-1	R/W-1
—	—	INT4R5	INT4R4	INT4R3	INT4R2	INT4R1	INT4R0
bit 7							bit 0

### Legend:

R = Readable bit      W = Writable bit      U = Unimplemented bit, read as '0'  
 -n = Value at POR      '1' = Bit is set      '0' = Bit is cleared      x = Bit is unknown

bit 15-6      **Unimplemented:** Read as '0'  
 bit 5-0      **INT4R[5:0]:** Assign External Interrupt 4 (INT4) to Corresponding RPn or RPIIn Pin bits

## REGISTER 10-4: RPINR3: PERIPHERAL PIN SELECT INPUT REGISTER 3

U-0	U-0	R/W-1	R/W-1	R/W-1	R/W-1	R/W-1	R/W-1
—	—	T3CKR5	T3CKR4	T3CKR3	T3CKR2	T3CKR1	T3CKR0
bit 15							bit 8

U-0	U-0	R/W-1	R/W-1	R/W-1	R/W-1	R/W-1	R/W-1
—	—	T2CKR5	T2CKR4	T2CKR3	T2CKR2	T2CKR1	T2CKR0
bit 7							bit 0

### Legend:

R = Readable bit      W = Writable bit      U = Unimplemented bit, read as '0'  
 -n = Value at POR      '1' = Bit is set      '0' = Bit is cleared      x = Bit is unknown

bit 15-14      **Unimplemented:** Read as '0'  
 bit 13-8      **T3CKR[5:0]:** Assign Timer3 External Clock (T3CK) to Corresponding RPn or RPIIn Pin bits  
 bit 7-6      **Unimplemented:** Read as '0'  
 bit 5-0      **T2CKR[5:0]:** Assign Timer2 External Clock (T2CK) to Corresponding RPn or RPIIn Pin bits

# PIC24FJ256GA110 FAMILY

## REGISTER 10-5: RPINR4: PERIPHERAL PIN SELECT INPUT REGISTER 4

U-0	U-0	R/W-1	R/W-1	R/W-1	R/W-1	R/W-1	R/W-1
—	—	T5CKR5	T5CKR4	T5CKR3	T5CKR2	T5CKR1	T5CKR0
bit 15							bit 8

U-0	U-0	R/W-1	R/W-1	R/W-1	R/W-1	R/W-1	R/W-1
—	—	T4CKR5	T4CKR4	T4CKR3	T4CKR2	T4CKR1	T4CKR0
bit 7							bit 0

### Legend:

R = Readable bit                      W = Writable bit                      U = Unimplemented bit, read as '0'  
 -n = Value at POR                      '1' = Bit is set                      '0' = Bit is cleared                      x = Bit is unknown

- bit 15-14     **Unimplemented:** Read as '0'
- bit 13-8     **T5CKR[5:0]:** Assign Timer5 External Clock (T5CK) to Corresponding RPn or RPIn Pin bits
- bit 7-6      **Unimplemented:** Read as '0'
- bit 5-0      **T4CKR[5:0]:** Assign Timer4 External Clock (T4CK) to Corresponding RPn or RPIn Pin bits

## REGISTER 10-6: RPINR7: PERIPHERAL PIN SELECT INPUT REGISTER 7

U-0	U-0	R/W-1	R/W-1	R/W-1	R/W-1	R/W-1	R/W-1
—	—	IC2R5	IC2R4	IC2R3	IC2R2	IC2R1	IC2R0
bit 15							bit 8

U-0	U-0	R/W-1	R/W-1	R/W-1	R/W-1	R/W-1	R/W-1
—	—	IC1R5	IC1R4	IC1R3	IC1R2	IC1R1	IC1R0
bit 7							bit 0

### Legend:

R = Readable bit                      W = Writable bit                      U = Unimplemented bit, read as '0'  
 -n = Value at POR                      '1' = Bit is set                      '0' = Bit is cleared                      x = Bit is unknown

- bit 15-14     **Unimplemented:** Read as '0'
- bit 13-8     **IC2R[5:0]:** Assign Input Capture 2 (IC2) to Corresponding RPn or RPIn Pin bits
- bit 7-6      **Unimplemented:** Read as '0'
- bit 5-0      **IC1R[5:0]:** Assign Input Capture 1 (IC1) to Corresponding RPn or RPIn Pin bits

# PIC24FJ256GA110 FAMILY

## REGISTER 10-7: RPINR8: PERIPHERAL PIN SELECT INPUT REGISTER 8

U-0	U-0	R/W-1	R/W-1	R/W-1	R/W-1	R/W-1	R/W-1
—	—	IC4R5	IC4R4	IC4R3	IC4R2	IC4R1	IC4R0
bit 15							bit 8

U-0	U-0	R/W-1	R/W-1	R/W-1	R/W-1	R/W-1	R/W-1
—	—	IC3R5	IC3R4	IC3R3	IC3R2	IC3R1	IC3R0
bit 7							bit 0

### Legend:

R = Readable bit                      W = Writable bit                      U = Unimplemented bit, read as '0'  
 -n = Value at POR                      '1' = Bit is set                      '0' = Bit is cleared                      x = Bit is unknown

- bit 15-14      **Unimplemented:** Read as '0'
- bit 13-8      **IC4R[5:0]:** Assign Input Capture 4 (IC4) to Corresponding RPn or RPIIn Pin bits
- bit 7-6      **Unimplemented:** Read as '0'
- bit 5-0      **IC3R[5:0]:** Assign Input Capture 3 (IC3) to Corresponding RPn or RPIIn Pin bits

## REGISTER 10-8: RPINR9: PERIPHERAL PIN SELECT INPUT REGISTER 9

U-0	U-0	R/W-1	R/W-1	R/W-1	R/W-1	R/W-1	R/W-1
—	—	IC6R5	IC6R4	IC6R3	IC6R2	IC6R1	IC6R0
bit 15							bit 8

U-0	U-0	R/W-1	R/W-1	R/W-1	R/W-1	R/W-1	R/W-1
—	—	IC5R5	IC5R4	IC5R3	IC5R2	IC5R1	IC5R0
bit 7							bit 0

### Legend:

R = Readable bit                      W = Writable bit                      U = Unimplemented bit, read as '0'  
 -n = Value at POR                      '1' = Bit is set                      '0' = Bit is cleared                      x = Bit is unknown

- bit 15-14      **Unimplemented:** Read as '0'
- bit 13-8      **IC6R[5:0]:** Assign Input Capture 6 (IC6) to Corresponding RPn or RPIIn Pin bits
- bit 7-6      **Unimplemented:** Read as '0'
- bit 5-0      **IC5R[5:0]:** Assign Input Capture 5 (IC5) to Corresponding RPn or RPIIn Pin bits

# PIC24FJ256GA110 FAMILY

## REGISTER 10-9: RPINR10: PERIPHERAL PIN SELECT INPUT REGISTER 10

U-0	U-0	R/W-1	R/W-1	R/W-1	R/W-1	R/W-1	R/W-1
—	—	IC8R5	IC8R4	IC8R3	IC8R2	IC8R1	IC8R0
bit 15							bit 8

U-0	U-0	R/W-1	R/W-1	R/W-1	R/W-1	R/W-1	R/W-1
—	—	IC7R5	IC7R4	IC7R3	IC7R2	IC7R1	IC7R0
bit 7							bit 0

### Legend:

R = Readable bit                      W = Writable bit                      U = Unimplemented bit, read as '0'  
 -n = Value at POR                      '1' = Bit is set                      '0' = Bit is cleared                      x = Bit is unknown

- bit 15-14     **Unimplemented:** Read as '0'
- bit 13-8     **IC8R[5:0]:** Assign Input Capture 8 (IC8) to Corresponding RPn or RPIIn Pin bits
- bit 7-6     **Unimplemented:** Read as '0'
- bit 5-0     **IC7R[5:0]:** Assign Input Capture 7 (IC7) to Corresponding RPn or RPIIn Pin bits

## REGISTER 10-10: RPINR11: PERIPHERAL PIN SELECT INPUT REGISTER 11

U-0	U-0	R/W-1	R/W-1	R/W-1	R/W-1	R/W-1	R/W-1
—	—	OCFBR5	OCFBR4	OCFBR3	OCFBR2	OCFBR1	OCFBR0
bit 15							bit 8

U-0	U-0	R/W-1	R/W-1	R/W-1	R/W-1	R/W-1	R/W-1
—	—	OCFAR5	OCFAR4	OCFAR3	OCFAR2	OCFAR1	OCFAR0
bit 7							bit 0

### Legend:

R = Readable bit                      W = Writable bit                      U = Unimplemented bit, read as '0'  
 -n = Value at POR                      '1' = Bit is set                      '0' = Bit is cleared                      x = Bit is unknown

- bit 15-14     **Unimplemented:** Read as '0'
- bit 13-8     **OCFBR[5:0]:** Assign Output Compare Fault B (OCFB) to Corresponding RPn or RPIIn Pin bits
- bit 7-6     **Unimplemented:** Read as '0'
- bit 5-0     **OCFAR[5:0]:** Assign Output Compare Fault A (OCFA) to Corresponding RPn or RPIIn Pin bits

# PIC24FJ256GA110 FAMILY

## REGISTER 10-11: RPINR15: PERIPHERAL PIN SELECT INPUT REGISTER 15

U-0	U-0	R/W-1	R/W-1	R/W-1	R/W-1	R/W-1	R/W-1
—	—	IC9R5	IC9R4	IC9R3	IC9R2	IC9R1	IC9R0
bit 15							bit 8

U-0	U-0	U-0	U-0	U-0	U-0	U-0	U-0
—	—	—	—	—	—	—	—
bit 7							bit 0

**Legend:**

R = Readable bit                      W = Writable bit                      U = Unimplemented bit, read as '0'  
 -n = Value at POR                      '1' = Bit is set                      '0' = Bit is cleared                      x = Bit is unknown

- bit 15-14      **Unimplemented:** Read as '0'
- bit 13-8      **IC9R[5:0]:** Assign Input Capture 9 (IC9) to Corresponding RPn or RPIn Pin bits
- bit 7-0        **Unimplemented:** Read as '0'

## REGISTER 10-12: RPINR17: PERIPHERAL PIN SELECT INPUT REGISTER 17

U-0	U-0	R/W-1	R/W-1	R/W-1	R/W-1	R/W-1	R/W-1
—	—	U3RXR5	U3RXR4	U3RXR3	U3RXR2	U3RXR1	U3RXR0
bit 15							bit 8

U-0	U-0	U-0	U-0	U-0	U-0	U-0	U-0
—	—	—	—	—	—	—	—
bit 7							bit 0

**Legend:**

R = Readable bit                      W = Writable bit                      U = Unimplemented bit, read as '0'  
 -n = Value at POR                      '1' = Bit is set                      '0' = Bit is cleared                      x = Bit is unknown

- bit 15-14      **Unimplemented:** Read as '0'
- bit 13-8      **U3RXR[5:0]:** Assign UART3 Receive (U3RX) to Corresponding RPn or RPIn Pin bits
- bit 7-0        **Unimplemented:** Read as '0'

# PIC24FJ256GA110 FAMILY

## REGISTER 10-13: RPINR18: PERIPHERAL PIN SELECT INPUT REGISTER 18

U-0	U-0	R/W-1	R/W-1	R/W-1	R/W-1	R/W-1	R/W-1
—	—	U1CTSR5	U1CTSR4	U1CTSR3	U1CTSR2	U1CTSR1	U1CTSR0
bit 15							bit 8

U-0	U-0	R/W-1	R/W-1	R/W-1	R/W-1	R/W-1	R/W-1
—	—	U1RXR5	U1RXR4	U1RXR3	U1RXR2	U1RXR1	U1RXR0
bit 7							bit 0

### Legend:

R = Readable bit                      W = Writable bit                      U = Unimplemented bit, read as '0'  
 -n = Value at POR                      '1' = Bit is set                      '0' = Bit is cleared                      x = Bit is unknown

- bit 15-14    **Unimplemented:** Read as '0'
- bit 13-8    **U1CTSR[5:0]:** Assign UART1 Clear-to-Send ( $\overline{U1CTS}$ ) to Corresponding RPn or RPIn Pin bits
- bit 7-6     **Unimplemented:** Read as '0'
- bit 5-0     **U1RXR[5:0]:** Assign UART1 Receive (U1RX) to Corresponding RPn or RPIn Pin bits

## REGISTER 10-14: RPINR19: PERIPHERAL PIN SELECT INPUT REGISTER 19

U-0	U-0	R/W-1	R/W-1	R/W-1	R/W-1	R/W-1	R/W-1
—	—	U2CTSR5	U2CTSR4	U2CTSR3	U2CTSR2	U2CTSR1	U2CTSR0
bit 15							bit 8

U-0	U-0	R/W-1	R/W-1	R/W-1	R/W-1	R/W-1	R/W-1
—	—	U2RXR5	U2RXR4	U2RXR3	U2RXR2	U2RXR1	U2RXR0
bit 7							bit 0

### Legend:

R = Readable bit                      W = Writable bit                      U = Unimplemented bit, read as '0'  
 -n = Value at POR                      '1' = Bit is set                      '0' = Bit is cleared                      x = Bit is unknown

- bit 15-14    **Unimplemented:** Read as '0'
- bit 13-8    **U2CTSR[5:0]:** Assign UART2 Clear-to-Send ( $\overline{U2CTS}$ ) to Corresponding RPn or RPIn Pin bits
- bit 7-6     **Unimplemented:** Read as '0'
- bit 5-0     **U2RXR[5:0]:** Assign UART2 Receive (U2RX) to Corresponding RPn or RPIn Pin bits

# PIC24FJ256GA110 FAMILY

## REGISTER 10-15: RPINR20: PERIPHERAL PIN SELECT INPUT REGISTER 20

U-0	U-0	R/W-1	R/W-1	R/W-1	R/W-1	R/W-1	R/W-1
—	—	SCK1R5	SCK1R4	SCK1R3	SCK1R2	SCK1R1	SCK1R0
bit 15							bit 8

U-0	U-0	R/W-1	R/W-1	R/W-1	R/W-1	R/W-1	R/W-1
—	—	SDI1R5	SDI1R4	SDI1R3	SDI1R2	SDI1R1	SDI1R0
bit 7							bit 0

### Legend:

R = Readable bit                      W = Writable bit                      U = Unimplemented bit, read as '0'  
 -n = Value at POR                      '1' = Bit is set                      '0' = Bit is cleared                      x = Bit is unknown

- bit 15-14      **Unimplemented:** Read as '0'
- bit 13-8      **SCK1R[5:0]:** Assign SPI1 Clock Input (SCK1IN) to Corresponding RPn or RPIIn Pin bits
- bit 7-6      **Unimplemented:** Read as '0'
- bit 5-0      **SDI1R[5:0]:** Assign SPI1 Data Input (SDI1) to Corresponding RPn or RPIIn Pin bits

## REGISTER 10-16: RPINR21: PERIPHERAL PIN SELECT INPUT REGISTER 21

U-0	U-0	R/W-1	R/W-1	R/W-1	R/W-1	R/W-1	R/W-1
—	—	U3CTSR5	U3CTSR4	U3CTSR3	U3CTSR2	U3CTSR1	U3CTSR0
bit 15							bit 8

U-0	U-0	R/W-1	R/W-1	R/W-1	R/W-1	R/W-1	R/W-1
—	—	SS1R5	SS1R4	SS1R3	SS1R2	SS1R1	SS1R0
bit 7							bit 0

### Legend:

R = Readable bit                      W = Writable bit                      U = Unimplemented bit, read as '0'  
 -n = Value at POR                      '1' = Bit is set                      '0' = Bit is cleared                      x = Bit is unknown

- bit 15-14      **Unimplemented:** Read as '0'
- bit 13-8      **U3CTSR[5:0]:** Assign UART3 Clear-to-Send ( $\overline{U3CTS}$ ) to Corresponding RPn or RPIIn Pin bits
- bit 7-6      **Unimplemented:** Read as '0'
- bit 5-0      **SS1R[5:0]:** Assign SPI1 Slave Select Input (SS1IN) to Corresponding RPn or RPIIn Pin bits

# PIC24FJ256GA110 FAMILY

## REGISTER 10-17: RPINR22: PERIPHERAL PIN SELECT INPUT REGISTER 22

U-0	U-0	R/W-1	R/W-1	R/W-1	R/W-1	R/W-1	R/W-1
—	—	SCK2R5	SCK2R4	SCK2R3	SCK2R2	SCK2R1	SCK2R0
bit 15							bit 8

U-0	U-0	R/W-1	R/W-1	R/W-1	R/W-1	R/W-1	R/W-1
—	—	SDI2R5	SDI2R4	SDI2R3	SDI2R2	SDI2R1	SDI2R0
bit 7							bit 0

### Legend:

R = Readable bit                      W = Writable bit                      U = Unimplemented bit, read as '0'  
 -n = Value at POR                      '1' = Bit is set                      '0' = Bit is cleared                      x = Bit is unknown

- bit 15-14     **Unimplemented:** Read as '0'
- bit 13-8     **SCK2R[5:0]:** Assign SPI2 Clock Input (SCK2IN) to Corresponding RPn or RPIIn Pin bits
- bit 7-6      **Unimplemented:** Read as '0'
- bit 5-0      **SDI2R[5:0]:** Assign SPI2 Data Input (SDI2) to Corresponding RPn or RPIIn Pin bits

## REGISTER 10-18: RPINR23: PERIPHERAL PIN SELECT INPUT REGISTER 23

U-0	U-0	U-0	U-0	U-0	U-0	U-0	U-0
—	—	—	—	—	—	—	—
bit 15							bit 8

U-0	U-0	R/W-1	R/W-1	R/W-1	R/W-1	R/W-1	R/W-1
—	—	SS2R5	SS2R4	SS2R3	SS2R2	SS2R1	SS2R0
bit 7							bit 0

### Legend:

R = Readable bit                      W = Writable bit                      U = Unimplemented bit, read as '0'  
 -n = Value at POR                      '1' = Bit is set                      '0' = Bit is cleared                      x = Bit is unknown

- bit 15-6     **Unimplemented:** Read as '0'
- bit 5-0      **SS2R[5:0]:** Assign SPI2 Slave Select Input (SS2IN) to Corresponding RPn or RPIIn Pin bits

# PIC24FJ256GA110 FAMILY

## REGISTER 10-19: RPINR27: PERIPHERAL PIN SELECT INPUT REGISTER 27

U-0	U-0	R/W-1	R/W-1	R/W-1	R/W-1	R/W-1	R/W-1
—	—	U4CTSR5	U4CTSR4	U4CTSR3	U4CTSR2	U4CTSR1	U4CTSR0
bit 15							bit 8

U-0	U-0	R/W-1	R/W-1	R/W-1	R/W-1	R/W-1	R/W-1
—	—	U4RXR5	U4RXR4	U4RXR3	U4RXR2	U4RXR1	U4RXR0
bit 7							bit 0

### Legend:

R = Readable bit                      W = Writable bit                      U = Unimplemented bit, read as '0'  
 -n = Value at POR                      '1' = Bit is set                      '0' = Bit is cleared                      x = Bit is unknown

- bit 15-14      **Unimplemented:** Read as '0'
- bit 13-8      **U4CTSR[5:0]:** Assign UART4 Clear-to-Send ( $\overline{U4CTS}$ ) to Corresponding RPn or RPIIn Pin bits
- bit 7-6        **Unimplemented:** Read as '0'
- bit 5-0        **U4RXR[5:0]:** Assign UART4 Receive (U4RX) to Corresponding RPn or RPIIn Pin bits

## REGISTER 10-20: RPINR28: PERIPHERAL PIN SELECT INPUT REGISTER 28

U-0	U-0	R/W-1	R/W-1	R/W-1	R/W-1	R/W-1	R/W-1
—	—	SCK3R5	SCK3R4	SCK3R3	SCK3R2	SCK3R1	SCK3R0
bit 15							bit 8

U-0	U-0	R/W-1	R/W-1	R/W-1	R/W-1	R/W-1	R/W-1
—	—	SDI3R5	SDI3R4	SDI3R3	SDI3R2	SDI3R1	SDI3R0
bit 7							bit 0

### Legend:

R = Readable bit                      W = Writable bit                      U = Unimplemented bit, read as '0'  
 -n = Value at POR                      '1' = Bit is set                      '0' = Bit is cleared                      x = Bit is unknown

- bit 15-14      **Unimplemented:** Read as '0'
- bit 13-8      **SCK3R[5:0]:** Assign SPI3 Clock Input (SCK3IN) to Corresponding RPn or RPIIn Pin bits
- bit 7-6        **Unimplemented:** Read as '0'
- bit 5-0        **SDI3R[5:0]:** Assign SPI3 Data Input (SDI3) to Corresponding RPn or RPIIn Pin bits

# PIC24FJ256GA110 FAMILY

## REGISTER 10-21: RPINR29: PERIPHERAL PIN SELECT INPUT REGISTER 29

U-0	U-0	U-0	U-0	U-0	U-0	U-0	U-0
—	—	—	—	—	—	—	—
bit 15							bit 8

U-0	U-0	R/W-1	R/W-1	R/W-1	R/W-1	R/W-1	R/W-1
—	—	SS3R5	SS3R4	SS3R3	SS3R2	SS3R1	SS3R0
bit 7							bit 0

### Legend:

R = Readable bit

W = Writable bit

U = Unimplemented bit, read as '0'

-n = Value at POR

'1' = Bit is set

'0' = Bit is cleared

x = Bit is unknown

bit 15-6      **Unimplemented:** Read as '0'

bit 5-0      **SS3R[5:0]:** Assign SPI3 Slave Select Input (SS31IN) to Corresponding RPN or RPN Pin bits

# PIC24FJ256GA110 FAMILY

## REGISTER 10-22: RPOR0: PERIPHERAL PIN SELECT OUTPUT REGISTER 0

U-0	U-0	R/W-0	R/W-0	R/W-0	R/W-0	R/W-0	R/W-0
—	—	RP1R5	RP1R4	RP1R3	RP1R2	RP1R1	RP1R0
bit 15							bit 8

U-0	U-0	R/W-0	R/W-0	R/W-0	R/W-0	R/W-0	R/W-0
—	—	RP0R5	RP0R4	RP0R3	RP0R2	RP0R1	RP0R0
bit 7							bit 0

### Legend:

R = Readable bit                      W = Writable bit                      U = Unimplemented bit, read as '0'  
 -n = Value at POR                      '1' = Bit is set                      '0' = Bit is cleared                      x = Bit is unknown

- bit 15-14      **Unimplemented:** Read as '0'
- bit 13-8      **RP1R[5:0]:** RP1 Output Pin Mapping bits  
Peripheral output number n is assigned to pin, RP1 (see [Table 10-3](#) for peripheral function numbers).
- bit 7-6        **Unimplemented:** Read as '0'
- bit 5-0        **RP0R[5:0]:** RP0 Output Pin Mapping bits  
Peripheral output number n is assigned to pin, RP0 (see [Table 10-3](#) for peripheral function numbers).

## REGISTER 10-23: RPOR1: PERIPHERAL PIN SELECT OUTPUT REGISTER 1

U-0	U-0	R/W-0	R/W-0	R/W-0	R/W-0	R/W-0	R/W-0
—	—	RP3R5	RP3R4	RP3R3	RP3R2	RP3R1	RP3R0
bit 15							bit 8

U-0	U-0	R/W-0	R/W-0	R/W-0	R/W-0	R/W-0	R/W-0
—	—	RP2R5	RP2R4	RP2R3	RP2R2	RP2R1	RP2R0
bit 7							bit 0

### Legend:

R = Readable bit                      W = Writable bit                      U = Unimplemented bit, read as '0'  
 -n = Value at POR                      '1' = Bit is set                      '0' = Bit is cleared                      x = Bit is unknown

- bit 15-14      **Unimplemented:** Read as '0'
- bit 13-8      **RP3R[5:0]:** RP3 Output Pin Mapping bits  
Peripheral output number n is assigned to pin, RP3 (see [Table 10-3](#) for peripheral function numbers).
- bit 7-6        **Unimplemented:** Read as '0'
- bit 5-0        **RP2R[5:0]:** RP2 Output Pin Mapping bits  
Peripheral output number n is assigned to pin, RP2 (see [Table 10-3](#) for peripheral function numbers).

# PIC24FJ256GA110 FAMILY

## REGISTER 10-24: RPOR2: PERIPHERAL PIN SELECT OUTPUT REGISTER 2

U-0	U-0	R/W-0	R/W-0	R/W-0	R/W-0	R/W-0	R/W-0
—	—	RP5R5 <sup>(1)</sup>	RP5R4 <sup>(1)</sup>	RP5R3 <sup>(1)</sup>	RP5R2 <sup>(1)</sup>	RP5R1 <sup>(1)</sup>	RP5R0 <sup>(1)</sup>
bit 15							bit 8

U-0	U-0	R/W-0	R/W-0	R/W-0	R/W-0	R/W-0	R/W-0
—	—	RP4R5	RP4R4	RP4R3	RP4R2	RP4R1	RP4R0
bit 7							bit 0

### Legend:

R = Readable bit  
-n = Value at POR

W = Writable bit  
'1' = Bit is set

U = Unimplemented bit, read as '0'  
'0' = Bit is cleared  
x = Bit is unknown

bit 15-14 **Unimplemented:** Read as '0'

bit 13-8 **RP5R[5:0]:** RP5 Output Pin Mapping bits<sup>(1)</sup>  
Peripheral output number n is assigned to pin, RP5 (see [Table 10-3](#) for peripheral function numbers).

bit 7-6 **Unimplemented:** Read as '0'

bit 5-0 **RP4R[5:0]:** RP4 Output Pin Mapping bits  
Peripheral output number n is assigned to pin, RP4 (see [Table 10-3](#) for peripheral function numbers).

**Note 1:** Unimplemented in 64-pin devices; read as '0'.

## REGISTER 10-25: RPOR3: PERIPHERAL PIN SELECT OUTPUT REGISTER 3

U-0	U-0	R/W-0	R/W-0	R/W-0	R/W-0	R/W-0	R/W-0
—	—	RP7R5	RP7R4	RP7R3	RP7R2	RP7R1	RP7R0
bit 15							bit 8

U-0	U-0	R/W-0	R/W-0	R/W-0	R/W-0	R/W-0	R/W-0
—	—	RP6R5	RP6R4	RP6R3	RP6R2	RP6R1	RP6R0
bit 7							bit 0

### Legend:

R = Readable bit  
-n = Value at POR

W = Writable bit  
'1' = Bit is set

U = Unimplemented bit, read as '0'  
'0' = Bit is cleared  
x = Bit is unknown

bit 15-14 **Unimplemented:** Read as '0'

bit 13-8 **RP7R[5:0]:** RP7 Output Pin Mapping bits  
Peripheral output number n is assigned to pin, RP7 (see [Table 10-3](#) for peripheral function numbers).

bit 7-6 **Unimplemented:** Read as '0'

bit 5-0 **RP6R[5:0]:** RP6 Output Pin Mapping bits  
Peripheral output number n is assigned to pin, RP6 (see [Table 10-3](#) for peripheral function numbers).

# PIC24FJ256GA110 FAMILY

## REGISTER 10-26: RPOR4: PERIPHERAL PIN SELECT OUTPUT REGISTER 4

U-0	U-0	R/W-0	R/W-0	R/W-0	R/W-0	R/W-0	R/W-0
—	—	RP9R5	RP9R4	RP9R3	RP9R2	RP9R1	RP9R0
bit 15							bit 8

U-0	U-0	R/W-0	R/W-0	R/W-0	R/W-0	R/W-0	R/W-0
—	—	RP8R5	RP8R4	RP8R3	RP8R2	RP8R1	RP8R0
bit 7							bit 0

### Legend:

R = Readable bit      W = Writable bit      U = Unimplemented bit, read as '0'  
 -n = Value at POR      '1' = Bit is set      '0' = Bit is cleared      x = Bit is unknown

- bit 15-14      **Unimplemented:** Read as '0'
- bit 13-8      **RP9R[5:0]:** RP9 Output Pin Mapping bits  
 Peripheral output number n is assigned to pin, RP9 (see [Table 10-3](#) for peripheral function numbers).
- bit 7-6      **Unimplemented:** Read as '0'
- bit 5-0      **RP8R[5:0]:** RP8 Output Pin Mapping bits  
 Peripheral output number n is assigned to pin, RP8 (see [Table 10-3](#) for peripheral function numbers).

## REGISTER 10-27: RPOR5: PERIPHERAL PIN SELECT OUTPUT REGISTER 5

U-0	U-0	R/W-0	R/W-0	R/W-0	R/W-0	R/W-0	R/W-0
—	—	RP11R5	RP11R4	RP11R3	RP11R2	RP11R1	RP11R0
bit 15							bit 8

U-0	U-0	R/W-0	R/W-0	R/W-0	R/W-0	R/W-0	R/W-0
—	—	RP10R5	RP10R4	RP10R3	RP10R2	RP10R1	RP10R0
bit 7							bit 0

### Legend:

R = Readable bit      W = Writable bit      U = Unimplemented bit, read as '0'  
 -n = Value at POR      '1' = Bit is set      '0' = Bit is cleared      x = Bit is unknown

- bit 15-14      **Unimplemented:** Read as '0'
- bit 13-8      **RP11R[5:0]:** RP11 Output Pin Mapping bits  
 Peripheral output number n is assigned to pin, RP11 (see [Table 10-3](#) for peripheral function numbers).
- bit 7-6      **Unimplemented:** Read as '0'
- bit 5-0      **RP10R[5:0]:** RP10 Output Pin Mapping bits  
 Peripheral output number n is assigned to pin, RP10 (see [Table 10-3](#) for peripheral function numbers).

# PIC24FJ256GA110 FAMILY

## REGISTER 10-28: RPOR6: PERIPHERAL PIN SELECT OUTPUT REGISTER 6

U-0	U-0	R/W-0	R/W-0	R/W-0	R/W-0	R/W-0	R/W-0
—	—	RP13R5	RP13R4	RP13R3	RP13R2	RP13R1	RP13R0
bit 15							bit 8

U-0	U-0	R/W-0	R/W-0	R/W-0	R/W-0	R/W-0	R/W-0
—	—	RP12R5	RP12R4	RP12R3	RP12R2	RP12R1	RP12R0
bit 7							bit 0

### Legend:

R = Readable bit                      W = Writable bit                      U = Unimplemented bit, read as '0'  
 -n = Value at POR                      '1' = Bit is set                      '0' = Bit is cleared                      x = Bit is unknown

- bit 15-14    **Unimplemented:** Read as '0'
- bit 13-8    **RP13R[5:0]:** RP13 Output Pin Mapping bits  
Peripheral output number n is assigned to pin, RP13 (see [Table 10-3](#) for peripheral function numbers).
- bit 7-6     **Unimplemented:** Read as '0'
- bit 5-0     **RP12R[5:0]:** RP12 Output Pin Mapping bits  
Peripheral output number n is assigned to pin, RP12 (see [Table 10-3](#) for peripheral function numbers).

## REGISTER 10-29: RPOR7: PERIPHERAL PIN SELECT OUTPUT REGISTER 7

U-0	U-0	R/W-0	R/W-0	R/W-0	R/W-0	R/W-0	R/W-0
—	—	RP15R5 <sup>(1)</sup>	RP15R4 <sup>(1)</sup>	RP15R3 <sup>(1)</sup>	RP15R2 <sup>(1)</sup>	RP15R1 <sup>(1)</sup>	RP15R0 <sup>(1)</sup>
bit 15							bit 8

U-0	U-0	R/W-0	R/W-0	R/W-0	R/W-0	R/W-0	R/W-0
—	—	RP14R5	RP14R4	RP14R3	RP14R2	RP14R1	RP14R0
bit 7							bit 0

### Legend:

R = Readable bit                      W = Writable bit                      U = Unimplemented bit, read as '0'  
 -n = Value at POR                      '1' = Bit is set                      '0' = Bit is cleared                      x = Bit is unknown

- bit 15-14    **Unimplemented:** Read as '0'
- bit 13-8    **RP15R[5:0]:** RP15 Output Pin Mapping bits<sup>(1)</sup>  
Peripheral output number n is assigned to pin, RP15 (see [Table 10-3](#) for peripheral function numbers).
- bit 7-6     **Unimplemented:** Read as '0'
- bit 5-0     **RP14R[5:0]:** RP14 Output Pin Mapping bits  
Peripheral output number n is assigned to pin, RP14 (see [Table 10-3](#) for peripheral function numbers).

**Note 1:** Unimplemented in 64-pin devices; read as '0'.

# PIC24FJ256GA110 FAMILY

## REGISTER 10-30: RPOR8: PERIPHERAL PIN SELECT OUTPUT REGISTER 8

U-0	U-0	R/W-0	R/W-0	R/W-0	R/W-0	R/W-0	R/W-0
—	—	RP17R5	RP17R4	RP17R3	RP17R2	RP17R1	RP17R0
bit 15							bit 8

U-0	U-0	R/W-0	R/W-0	R/W-0	R/W-0	R/W-0	R/W-0
—	—	RP16R5	RP16R4	RP16R3	RP16R2	RP16R1	RP16R0
bit 7							bit 0

### Legend:

R = Readable bit                      W = Writable bit                      U = Unimplemented bit, read as '0'  
 -n = Value at POR                      '1' = Bit is set                      '0' = Bit is cleared                      x = Bit is unknown

- bit 15-14      **Unimplemented:** Read as '0'
- bit 13-8      **RP17R[5:0]:** RP17 Output Pin Mapping bits  
                   Peripheral output number n is assigned to pin, RP17 (see [Table 10-3](#) for peripheral function numbers).
- bit 7-6        **Unimplemented:** Read as '0'
- bit 5-0        **RP16R[5:0]:** RP16 Output Pin Mapping bits  
                   Peripheral output number n is assigned to pin, RP16 (see [Table 10-3](#) for peripheral function numbers).

## REGISTER 10-31: RPOR9: PERIPHERAL PIN SELECT OUTPUT REGISTER 9

U-0	U-0	R/W-0	R/W-0	R/W-0	R/W-0	R/W-0	R/W-0
—	—	RP19R5	RP19R4	RP19R3	RP19R2	RP19R1	RP19R0
bit 15							bit 8

U-0	U-0	R/W-0	R/W-0	R/W-0	R/W-0	R/W-0	R/W-0
—	—	RP18R5	RP18R4	RP18R3	RP18R2	RP18R1	RP18R0
bit 7							bit 0

### Legend:

R = Readable bit                      W = Writable bit                      U = Unimplemented bit, read as '0'  
 -n = Value at POR                      '1' = Bit is set                      '0' = Bit is cleared                      x = Bit is unknown

- bit 15-14      **Unimplemented:** Read as '0'
- bit 13-8      **RP19R[5:0]:** RP19 Output Pin Mapping bits  
                   Peripheral output number n is assigned to pin, RP19 (see [Table 10-3](#) for peripheral function numbers).
- bit 7-6        **Unimplemented:** Read as '0'
- bit 5-0        **RP18R[5:0]:** RP18 Output Pin Mapping bits  
                   Peripheral output number n is assigned to pin, RP18 (see [Table 10-3](#) for peripheral function numbers).

# PIC24FJ256GA110 FAMILY

## REGISTER 10-32: RPOR10: PERIPHERAL PIN SELECT OUTPUT REGISTER 10

U-0	U-0	R/W-0	R/W-0	R/W-0	R/W-0	R/W-0	R/W-0
—	—	RP21R5	RP21R4	RP21R3	RP21R2	RP21R1	RP21R0
bit 15							bit 8

U-0	U-0	R/W-0	R/W-0	R/W-0	R/W-0	R/W-0	R/W-0
—	—	RP20R5	RP20R4	RP20R3	RP20R2	RP20R1	RP20R0
bit 7							bit 0

### Legend:

R = Readable bit  
-n = Value at POR

W = Writable bit  
'1' = Bit is set

U = Unimplemented bit, read as '0'  
'0' = Bit is cleared  
x = Bit is unknown

bit 15-14 **Unimplemented:** Read as '0'

bit 13-8 **RP21R[5:0]:** RP21 Output Pin Mapping bits  
Peripheral output number n is assigned to pin, RP21 (see [Table 10-3](#) for peripheral function numbers).

bit 7-6 **Unimplemented:** Read as '0'

bit 5-0 **RP20R[5:0]:** RP20 Output Pin Mapping bits  
Peripheral output number n is assigned to pin, RP20 (see [Table 10-3](#) for peripheral function numbers).

## REGISTER 10-33: RPOR11: PERIPHERAL PIN SELECT OUTPUT REGISTER 11

U-0	U-0	R/W-0	R/W-0	R/W-0	R/W-0	R/W-0	R/W-0
—	—	RP23R5	RP23R4	RP23R3	RP23R2	RP23R1	RP23R0
bit 15							bit 8

U-0	U-0	R/W-0	R/W-0	R/W-0	R/W-0	R/W-0	R/W-0
—	—	RP22R5	RP22R4	RP22R3	RP22R2	RP22R1	RP22R0
bit 7							bit 0

### Legend:

R = Readable bit  
-n = Value at POR

W = Writable bit  
'1' = Bit is set

U = Unimplemented bit, read as '0'  
'0' = Bit is cleared  
x = Bit is unknown

bit 15-14 **Unimplemented:** Read as '0'

bit 13-8 **RP23R[5:0]:** RP23 Output Pin Mapping bits  
Peripheral output number n is assigned to pin, RP23 (see [Table 10-3](#) for peripheral function numbers).

bit 7-6 **Unimplemented:** Read as '0'

bit 5-0 **RP22R[5:0]:** RP22 Output Pin Mapping bits  
Peripheral output number n is assigned to pin, RP22 (see [Table 10-3](#) for peripheral function numbers).

# PIC24FJ256GA110 FAMILY

## REGISTER 10-34: RPOR12: PERIPHERAL PIN SELECT OUTPUT REGISTER 12

U-0	U-0	R/W-0	R/W-0	R/W-0	R/W-0	R/W-0	R/W-0
—	—	RP25R5	RP25R4	RP25R3	RP25R2	RP25R1	RP25R0
bit 15							bit 8

U-0	U-0	R/W-0	R/W-0	R/W-0	R/W-0	R/W-0	R/W-0
—	—	RP24R5	RP24R4	RP24R3	RP24R2	RP24R1	RP24R0
bit 7							bit 0

### Legend:

R = Readable bit  
-n = Value at POR

W = Writable bit  
'1' = Bit is set

U = Unimplemented bit, read as '0'  
'0' = Bit is cleared  
x = Bit is unknown

bit 15-14 **Unimplemented:** Read as '0'

bit 13-8 **RP25R[5:0]:** RP25 Output Pin Mapping bits  
Peripheral output number n is assigned to pin, RP25 (see [Table 10-3](#) for peripheral function numbers).

bit 7-6 **Unimplemented:** Read as '0'

bit 5-0 **RP24R[5:0]:** RP24 Output Pin Mapping bits  
Peripheral output number n is assigned to pin, RP24 (see [Table 10-3](#) for peripheral function numbers).

## REGISTER 10-35: RPOR13: PERIPHERAL PIN SELECT OUTPUT REGISTER 13

U-0	U-0	R/W-0	R/W-0	R/W-0	R/W-0	R/W-0	R/W-0
—	—	RP27R5	RP27R4	RP27R3	RP27R2	RP27R1	RP27R0
bit 15							bit 8

U-0	U-0	R/W-0	R/W-0	R/W-0	R/W-0	R/W-0	R/W-0
—	—	RP26R5	RP26R4	RP26R3	RP26R2	RP26R1	RP26R0
bit 7							bit 0

### Legend:

R = Readable bit  
-n = Value at POR

W = Writable bit  
'1' = Bit is set

U = Unimplemented bit, read as '0'  
'0' = Bit is cleared  
x = Bit is unknown

bit 15-14 **Unimplemented:** Read as '0'

bit 13-8 **RP27R[5:0]:** RP27 Output Pin Mapping bits  
Peripheral output number n is assigned to pin, RP27 (see [Table 10-3](#) for peripheral function numbers).

bit 7-6 **Unimplemented:** Read as '0'

bit 5-0 **RP26R[5:0]:** RP26 Output Pin Mapping bits  
Peripheral output number n is assigned to pin, RP26 (see [Table 10-3](#) for peripheral function numbers).

# PIC24FJ256GA110 FAMILY

## REGISTER 10-36: RPOR14: PERIPHERAL PIN SELECT OUTPUT REGISTER 14

U-0	U-0	R/W-0	R/W-0	R/W-0	R/W-0	R/W-0	R/W-0
—	—	RP29R5	RP29R4	RP29R3	RP29R2	RP29R1	RP29R0
bit 15							bit 8

U-0	U-0	R/W-0	R/W-0	R/W-0	R/W-0	R/W-0	R/W-0
—	—	RP28R5	RP28R4	RP28R3	RP28R2	RP28R1	RP28R0
bit 7							bit 0

### Legend:

R = Readable bit                      W = Writable bit                      U = Unimplemented bit, read as '0'  
 -n = Value at POR                      '1' = Bit is set                      '0' = Bit is cleared                      x = Bit is unknown

- bit 15-14    **Unimplemented:** Read as '0'
- bit 13-8    **RP29R[5:0]:** RP29 Output Pin Mapping bits  
Peripheral output number n is assigned to pin, RP29 (see [Table 10-3](#) for peripheral function numbers).
- bit 7-6     **Unimplemented:** Read as '0'
- bit 5-0     **RP28R[5:0]:** RP28 Output Pin Mapping bits  
Peripheral output number n is assigned to pin, RP28 (see [Table 10-3](#) for peripheral function numbers).

## REGISTER 10-37: RPOR15: PERIPHERAL PIN SELECT OUTPUT REGISTER 15

U-0	U-0	R/W-0	R/W-0	R/W-0	R/W-0	R/W-0	R/W-0
—	—	RP31R5 <sup>(1)</sup>	RP31R4 <sup>(1)</sup>	RP31R3 <sup>(1)</sup>	RP31R2 <sup>(1)</sup>	RP31R1 <sup>(1)</sup>	RP31R0 <sup>(1)</sup>
bit 15							bit 8

U-0	U-0	R/W-0	R/W-0	R/W-0	R/W-0	R/W-0	R/W-0
—	—	RP30R5	RP30R4	RP30R3	RP30R2	RP30R1	RP30R0
bit 7							bit 0

### Legend:

R = Readable bit                      W = Writable bit                      U = Unimplemented bit, read as '0'  
 -n = Value at POR                      '1' = Bit is set                      '0' = Bit is cleared                      x = Bit is unknown

- bit 15-14    **Unimplemented:** Read as '0'
- bit 13-8    **RP31R[5:0]:** RP31 Output Pin Mapping bits<sup>(1)</sup>  
Peripheral output number n is assigned to pin, RP31 (see [Table 10-3](#) for peripheral function numbers).
- bit 7-6     **Unimplemented:** Read as '0'
- bit 5-0     **RP30R[5:0]:** RP30 Output Pin Mapping bits  
Peripheral output number n is assigned to pin, RP30 (see [Table 10-3](#) for peripheral function numbers).

**Note 1:** Unimplemented in 64-pin and 80-pin devices; read as '0'.

# PIC24FJ256GA110 FAMILY

## REGISTER 10-38: ALTRP: ALTERNATE PERIPHERAL PIN MAPPING REGISTER

U-0	U-0	U-0	U-0	U-0	U-0	U-0	U-0
—	—	—	—	—	—	—	—
bit 15							bit 8

U-0	U-0	U-0	U-0	U-0	U-0	U-0	R/W-0
—	—	—	—	—	—	—	SCK1CM
bit 7							bit 0

### Legend:

R = Readable bit	W = Writable bit	U = Unimplemented bit, read as '0'
-n = Value at POR	'1' = Bit is set	'0' = Bit is cleared
		x = Bit is unknown

bit 15-1

**Unimplemented:** Read as '0'

bit 0

**SCK1CM:** SCK1 Output Mapping Select bit

1 = SCK1 output function is mapped to the ASCK1 pin only

0 = SCK1 output function is mapped according to the RPORx registers

# PIC24FJ256GA110 FAMILY

## 11.0 TIMER1

**Note:** This data sheet summarizes the features of this group of PIC24F devices. It is not intended to be a comprehensive reference source. For more information, refer to “Timers” ([www.microchip.com/DS39704](http://www.microchip.com/DS39704)) in the “dsPIC33/PIC24 Family Reference Manual”. The information in this data sheet supersedes the information in the FRM.

The Timer1 module is a 16-bit timer which can serve as the time counter for the Real-Time Clock (RTC), or operate as a free-running, interval timer/counter. Timer1 can operate in three modes:

- 16-Bit Timer
- 16-Bit Synchronous Counter
- 16-Bit Asynchronous Counter

Timer1 also supports these features:

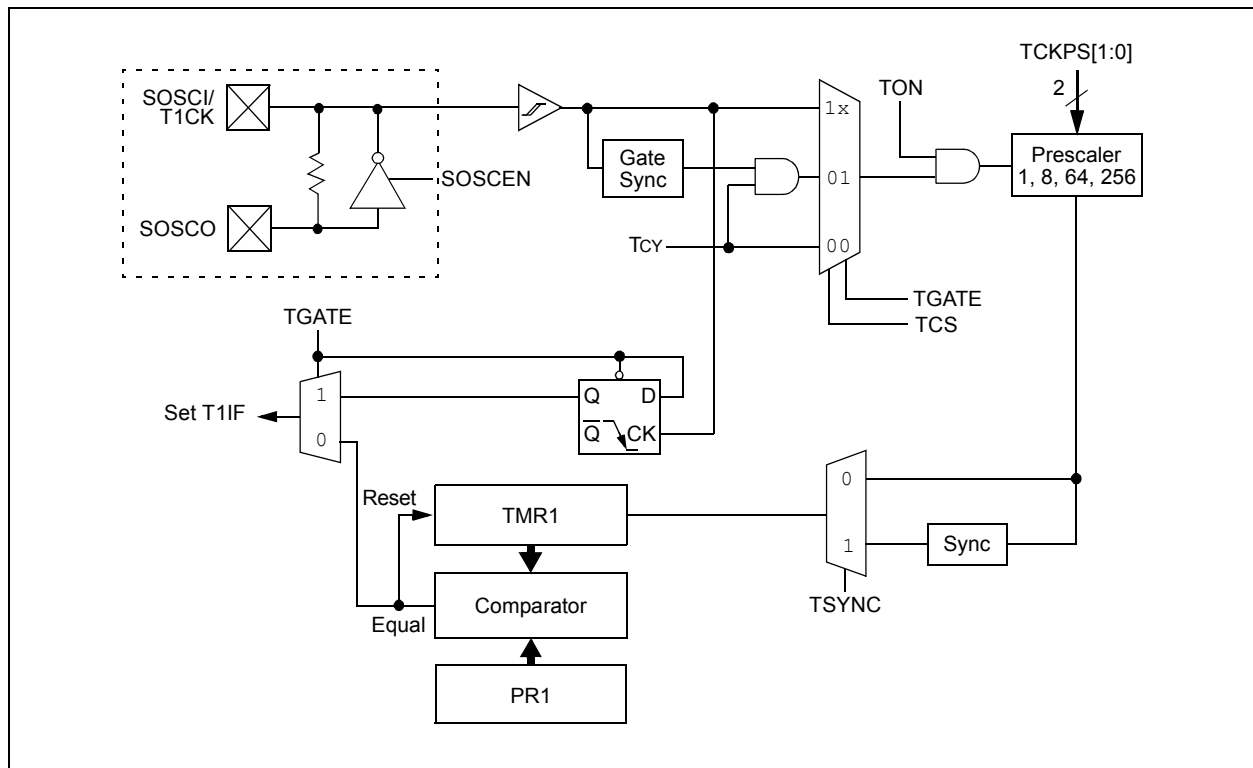
- Timer Gate Operation
- Selectable Prescaler Settings
- Timer Operation during CPU Idle mode
- Interrupt on 16-Bit Period Register Match or Falling Edge of External Gate Signal

Figure 11-1 presents a block diagram of the 16-bit timer module.

To configure Timer1 for operation:

1. Set the TON bit (= 1).
2. Select the timer prescaler ratio using the TCKPS[1:0] bits.
3. Set the Clock and Gating modes using the TCS and TGATE bits.
4. Set or clear the TSYNC bit to configure synchronous or asynchronous operation.
5. Load the timer period value into the PR1 register.
6. If interrupts are required, set the interrupt enable bit, T1IE. Use the priority bits, T1IP[2:0], to set the interrupt priority.

**FIGURE 11-1: 16-BIT TIMER1 MODULE BLOCK DIAGRAM**



# PIC24FJ256GA110 FAMILY

## REGISTER 11-1: T1CON: TIMER1 CONTROL REGISTER<sup>(1)</sup>

R/W-0	U-0	R/W-0	U-0	U-0	U-0	U-0	U-0
TON	—	TSIDL	—	—	—	—	—
bit 15						bit 8	

U-0	R/W-0	R/W-0	R/W-0	U-0	R/W-0	R/W-0	U-0
—	TGATE	TCKPS1	TCKPS0	—	TSYNC	TCS	—
bit 7						bit 0	

### Legend:

R = Readable bit                      W = Writable bit                      U = Unimplemented bit, read as '0'  
 -n = Value at POR                      '1' = Bit is set                      '0' = Bit is cleared                      x = Bit is unknown

- bit 15            **TON:** Timer1 On bit  
                   1 = Starts 16-bit Timer1  
                   0 = Stops 16-bit Timer1
- bit 14            **Unimplemented:** Read as '0'
- bit 13            **TSIDL:** Stop in Idle Mode bit  
                   1 = Discontinues module operation when device enters Idle mode  
                   0 = Continues module operation in Idle mode
- bit 12-7        **Unimplemented:** Read as '0'
- bit 6            **TGATE:** Timer1 Gated Time Accumulation Enable bit  
                   When TCS = 1:  
                   This bit is ignored.  
                   When TCS = 0:  
                   1 = Gated time accumulation enabled  
                   0 = Gated time accumulation disabled
- bit 5-4        **TCKPS[1:0]:** Timer1 Input Clock Prescale Select bits  
                   11 = 1:256  
                   10 = 1:64  
                   01 = 1:8  
                   00 = 1:1
- bit 3            **Unimplemented:** Read as '0'
- bit 2            **TSYNC:** Timer1 External Clock Input Synchronization Select bit  
                   When TCS = 1:  
                   1 = Synchronizes external clock input  
                   0 = Does not synchronize external clock input  
                   When TCS = 0:  
                   This bit is ignored.
- bit 1            **TCS:** Timer1 Clock Source Select bit  
                   1 = External clock from T1CK pin (on the rising edge)  
                   0 = Internal clock (Fosc/2)
- bit 0            **Unimplemented:** Read as '0'

**Note 1:** Changing the value of TxCON while the timer is running (TON = 1) causes the timer prescale counter to reset and is not recommended.

## 12.0 TIMER2/3 AND TIMER4/5

**Note:** This data sheet summarizes the features of this group of PIC24F devices. It is not intended to be a comprehensive reference source. For more information, refer to “**Timers**” ([www.microchip.com/DS39704](http://www.microchip.com/DS39704)) in the “*dsPIC33/PIC24 Family Reference Manual*”. The information in this data sheet supersedes the information in the FRM.

The Timer2/3 and Timer4/5 modules are 32-bit timers, which can also be configured as four independent 16-bit timers with selectable operating modes.

As 32-bit timers, Timer2/3 and Timer4/5 can each operate in three modes:

- Two Independent 16-Bit Timers with All 16-Bit Operating modes (except Asynchronous Counter mode)
- Single 32-Bit Timer
- Single 32-Bit Synchronous Counter

They also support these features:

- Timer Gate Operation
- Selectable Prescaler Settings
- Timer Operation during Idle mode
- Interrupt on a 32-Bit Period Register Match
- ADC Event Trigger (Timer2/3 only)

Individually, all four of the 16-bit timers can function as synchronous timers or counters. They also offer the features listed above, except for the ADC event trigger; this is implemented only with Timer3. The operating modes and enabled features are determined by setting the appropriate bit(s) in the T2CON, T3CON, T4CON and T5CON registers. T2CON and T4CON are shown in generic form in [Register 12-1](#); T3CON and T5CON are shown in [Register 12-2](#).

For 32-bit timer/counter operation, Timer2 and Timer4 are the least significant word; Timer3 and Timer4 are the most significant word of the 32-bit timers.

**Note:** For 32-bit operation, T3CON and T5CON control bits are ignored. Only T2CON and T4CON control bits are used for setup and control. Timer2 and Timer4 clock and gate inputs are utilized for the 32-bit timer modules, but an interrupt is generated with the Timer3 or Timer5 interrupt flags.

To configure Timer2/3 or Timer4/5 for 32-bit operation:

1. Set the T32 bit (T2CON[3] or T4CON[3] = 1).
2. Select the prescaler ratio for Timer2 or Timer4 using the TCKPS[1:0] bits.
3. Set the Clock and Gating modes using the TCS and TGATE bits. If TCS is set to external clock, RPINRx (TxCK) must be configured to an available RPn pin. See [Section 10.4 “Peripheral Pin Select \(PPS\)”](#) for more information.
4. Load the timer period value. PR3 (or PR5) will contain the most significant word of the value while PR2 (or PR4) contains the least significant word.
5. If interrupts are required, set the interrupt enable bit, T3IE or T5IE; use the priority bits, T3IP[2:0] or T5IP[2:0], to set the interrupt priority. Note that while Timer2 or Timer4 controls the timer, the interrupt appears as a Timer3 or Timer5 interrupt.
6. Set the TON bit (= 1).

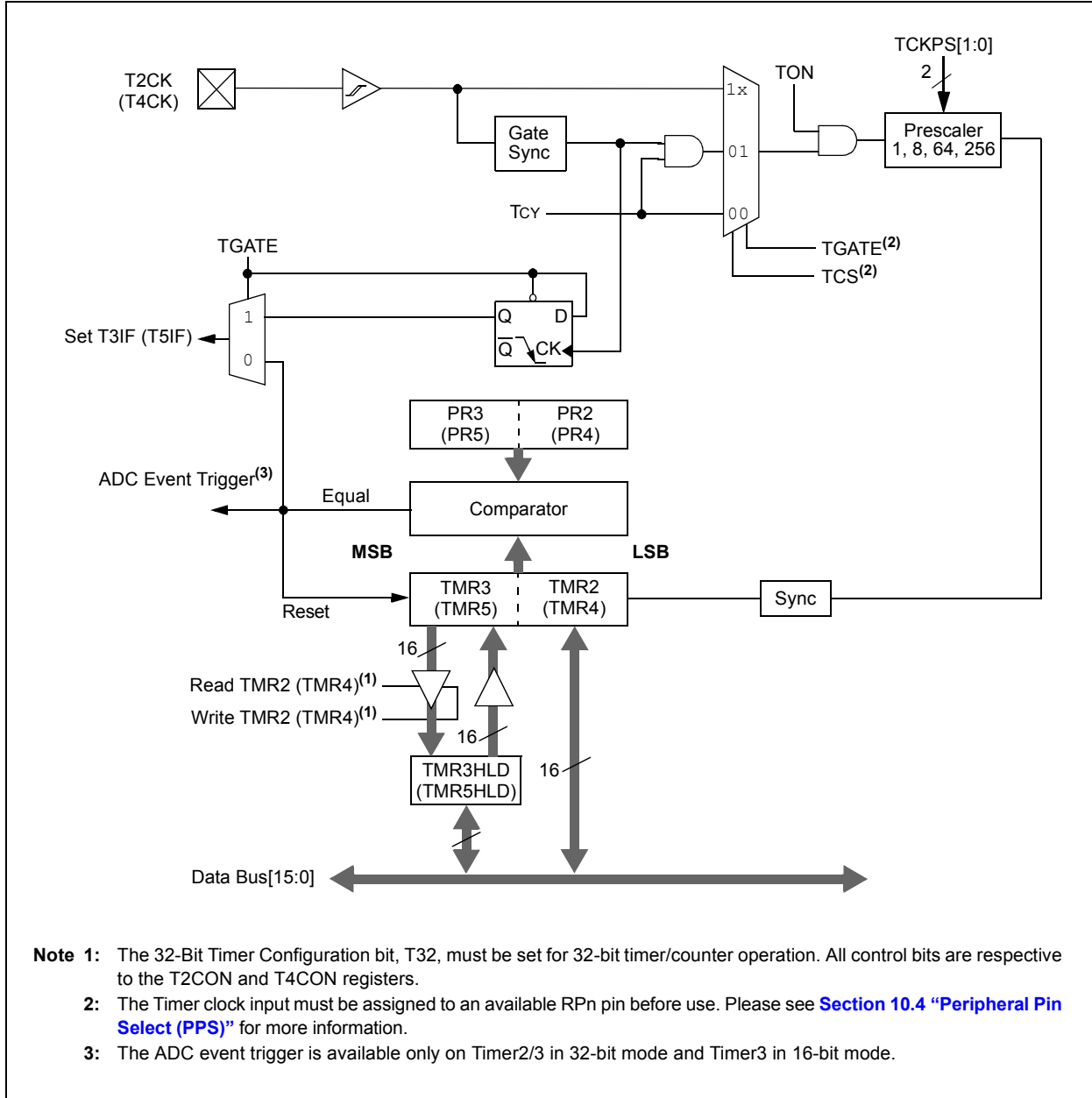
The timer value, at any point, is stored in the register pair: TMR3:TMR2 (or TMR5:TMR4). TMR3 (TMR5) always contains the most significant word of the count, while TMR2 (TMR4) contains the least significant word.

To configure any of the timers for individual 16-bit operation:

1. Clear the T32 bit corresponding to that timer (T2CON[3] for Timer2 and Timer3 or T4CON[3] for Timer4 and Timer5).
2. Select the timer prescaler ratio using the TCKPS[1:0] bits.
3. Set the Clock and Gating modes using the TCS and TGATE bits. See [Section 10.4 “Peripheral Pin Select \(PPS\)”](#) for more information.
4. Load the timer period value into the PRx register.
5. If interrupts are required, set the interrupt enable bit, TxIE; use the priority bits, TxIP[2:0], to set the interrupt priority.
6. Set the TON bit (TxCON[15] = 1).

# PIC24FJ256GA110 FAMILY

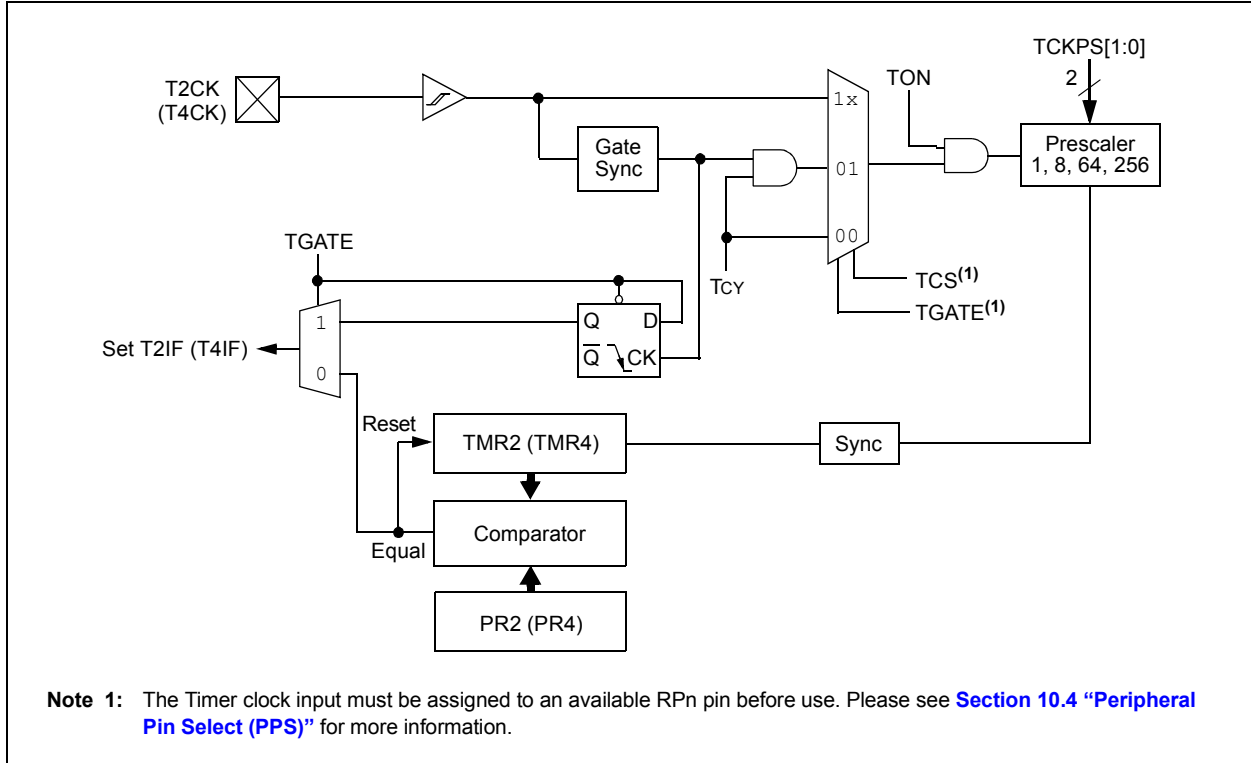
**FIGURE 12-1: TIMER2/3 AND TIMER4/5 (32-BIT) BLOCK DIAGRAM**



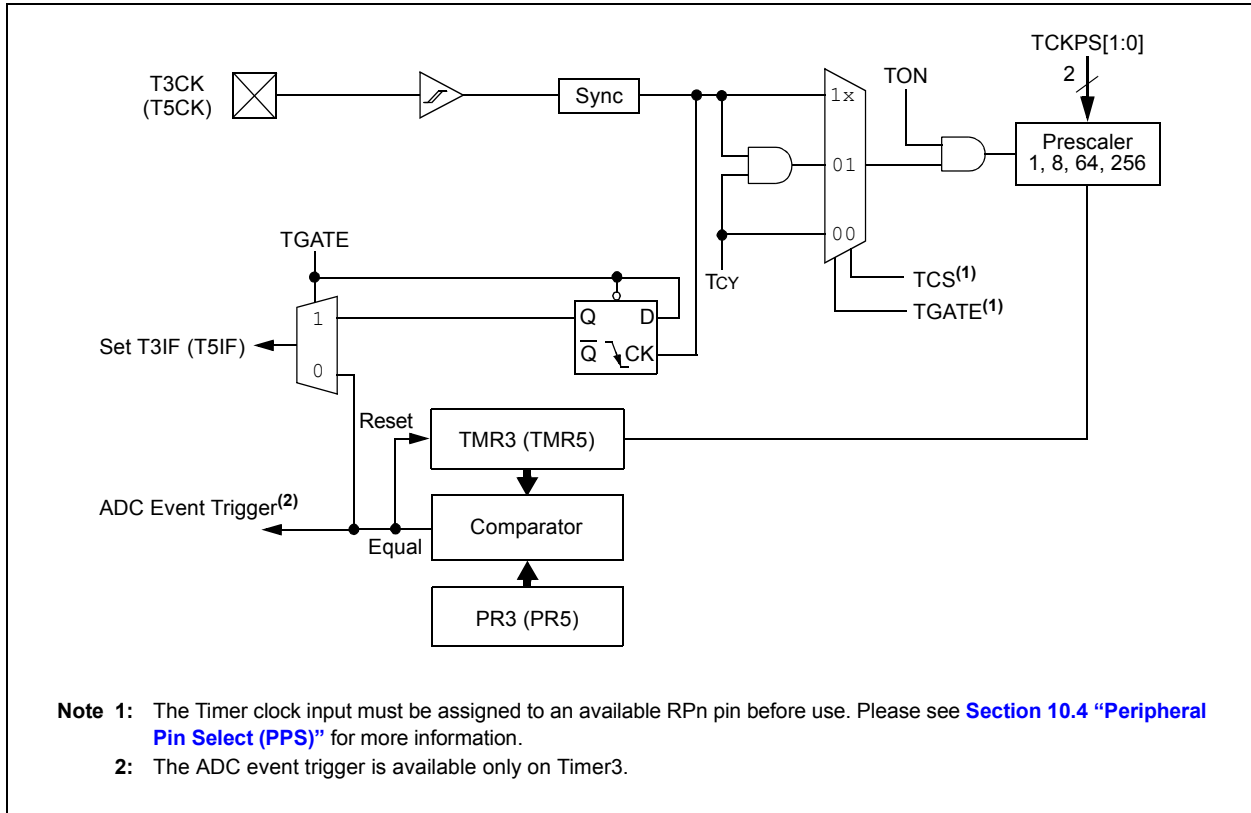
- Note 1:** The 32-Bit Timer Configuration bit, T32, must be set for 32-bit timer/counter operation. All control bits are respective to the T2CON and T4CON registers.
- 2:** The Timer clock input must be assigned to an available RPN pin before use. Please see [Section 10.4 “Peripheral Pin Select \(PPS\)”](#) for more information.
- 3:** The ADC event trigger is available only on Timer2/3 in 32-bit mode and Timer3 in 16-bit mode.

# PIC24FJ256GA110 FAMILY

**FIGURE 12-2: TIMER2 AND TIMER4 (16-BIT SYNCHRONOUS) BLOCK DIAGRAM**



**FIGURE 12-3: TIMER3 AND TIMER5 (16-BIT ASYNCHRONOUS) BLOCK DIAGRAM**



# PIC24FJ256GA110 FAMILY

**REGISTER 12-1: TxCON: TIMER2 AND TIMER4 CONTROL REGISTER<sup>(3)</sup>**

R/W-0	U-0	R/W-0	U-0	U-0	U-0	U-0	U-0
TON	—	TSIDL	—	—	—	—	—
bit 15						bit 8	

U-0	R/W-0	R/W-0	R/W-0	R/W-0	U-0	R/W-0	U-0
—	TGATE	TCKPS1	TCKPS0	T32 <sup>(1)</sup>	—	TCS <sup>(2)</sup>	—
bit 7						bit 0	

**Legend:**

R = Readable bit	W = Writable bit	U = Unimplemented bit, read as '0'
-n = Value at POR	'1' = Bit is set	'0' = Bit is cleared      x = Bit is unknown

- bit 15      **TON:** Timerx On bit  
When TxCON[3] = 1:  
 1 = Starts 32-bit Timerx/y  
 0 = Stops 32-bit Timerx/y  
When TxCON[3] = 0:  
 1 = Starts 16-bit Timerx  
 0 = Stops 16-bit Timerx
- bit 14      **Unimplemented:** Read as '0'
- bit 13      **TSIDL:** Stop in Idle Mode bit  
 1 = Discontinues module operation when device enters Idle mode  
 0 = Continues module operation in Idle mode
- bit 12-7    **Unimplemented:** Read as '0'
- bit 6      **TGATE:** Timerx Gated Time Accumulation Enable bit  
When TCS = 1:  
 This bit is ignored.  
When TCS = 0:  
 1 = Gated time accumulation enabled  
 0 = Gated time accumulation disabled
- bit 5-4     **TCKPS[1:0]:** Timerx Input Clock Prescale Select bits  
 11 = 1:256  
 10 = 1:64  
 01 = 1:8  
 00 = 1:1
- bit 3      **T32:** 32-Bit Timer Mode Select bit<sup>(1)</sup>  
 1 = Timerx and Timery form a single 32-bit timer  
 0 = Timerx and Timery act as two 16-bit timers  
 In 32-bit mode, T3CON control bits do not affect 32-bit timer operation.
- bit 2      **Unimplemented:** Read as '0'
- bit 1      **TCS:** Timerx Clock Source Select bit<sup>(2)</sup>  
 1 = External clock from pin, TxCK (on the rising edge)  
 0 = Internal clock (Fosc/2)
- bit 0      **Unimplemented:** Read as '0'

- Note 1:** In 32-bit mode, the T3CON or T5CON control bits do not affect 32-bit timer operation.
- 2:** If TCS = 1, RPINRx (TxCK) must be configured to an available RPN pin. For more information, see [Section 10.4 "Peripheral Pin Select \(PPS\)"](#).
- 3:** Changing the value of TxCON while the timer is running (TON = 1) causes the timer prescale counter to reset and is not recommended.

# PIC24FJ256GA110 FAMILY

**REGISTER 12-2: TyCON: TIMER3 AND TIMER5 CONTROL REGISTER<sup>(3)</sup>**

R/W-0	U-0	R/W-0	U-0	U-0	U-0	U-0	U-0
TON <sup>(1)</sup>	—	TSIDL <sup>(1)</sup>	—	—	—	—	—
bit 15						bit 8	

U-0	R/W-0	R/W-0	R/W-0	U-0	U-0	R/W-0	U-0
—	TGATE <sup>(1)</sup>	TCKPS1 <sup>(1)</sup>	TCKPS0 <sup>(1)</sup>	—	—	TCS <sup>(1,2)</sup>	—
bit 7						bit 0	

<b>Legend:</b>			
R = Readable bit	W = Writable bit	U = Unimplemented bit, read as '0'	
-n = Value at POR	'1' = Bit is set	'0' = Bit is cleared	x = Bit is unknown

- bit 15      **TON:** Timery On bit<sup>(1)</sup>  
               1 = Starts 16-bit Timery  
               0 = Stops 16-bit Timery
- bit 14      **Unimplemented:** Read as '0'
- bit 13      **TSIDL:** Stop in Idle Mode bit<sup>(1)</sup>  
               1 = Discontinues module operation when device enters Idle mode  
               0 = Continues module operation in Idle mode
- bit 12-7    **Unimplemented:** Read as '0'
- bit 6        **TGATE:** Timery Gated Time Accumulation Enable bit<sup>(1)</sup>  
               When TCS = 1:  
               This bit is ignored.  
               When TCS = 0:  
               1 = Gated time accumulation enabled  
               0 = Gated time accumulation disabled
- bit 5-4     **TCKPS[1:0]:** Timery Input Clock Prescale Select bits<sup>(1)</sup>  
               11 = 1:256  
               10 = 1:64  
               01 = 1:8  
               00 = 1:1
- bit 3-2     **Unimplemented:** Read as '0'
- bit 1        **TCS:** Timery Clock Source Select bit<sup>(1,2)</sup>  
               1 = External clock from pin, TyCK (on the rising edge)  
               0 = Internal clock (Fosc/2)
- bit 0        **Unimplemented:** Read as '0'

- Note 1:** When 32-bit operation is enabled (T2CON[3] or T4CON[3] = 1), these bits have no effect on Timery operation; all timer functions are set through T2CON and T4CON.
- 2:** If TCS = 1, RPINRx (TyCK) must be configured to an available RPn pin. See [Section 10.4 “Peripheral Pin Select \(PPS\)”](#) for more information.
- 3:** Changing the value of TyCON while the timer is running (TON = 1) causes the timer prescale counter to reset and is not recommended.

# PIC24FJ256GA110 FAMILY

---

NOTES:

# PIC24FJ256GA110 FAMILY

## 13.0 INPUT CAPTURE WITH DEDICATED TIMER

**Note:** This data sheet summarizes the features of this group of PIC24F devices. It is not intended to be a comprehensive reference source. For more information, refer to “Input Capture with Dedicated Timer” ([www.microchip.com/DS70000352](http://www.microchip.com/DS70000352)) in the “dsPIC33/PIC24 Family Reference Manual”. The information in this data sheet supersedes the information in the FRM.

Devices in the PIC24FJ256GA110 family all feature 9 independent enhanced input capture modules. Each of the modules offers a wide range of configuration and operating options for capturing external pulse events and generating interrupts.

Key features of the enhanced output module include:

- Hardware-Configurable for 32-Bit Operation in All modes by Cascading Two Adjacent Modules
- Synchronous and Trigger modes of Output compare Operation, with Up to 30 User-Selectable Trigger/Sync Sources Available
- A 4-Level FIFO Buffer for Capturing and Holding Timer Values for Several Events
- Configurable Interrupt Generation
- Up to Six Clock Sources Available for Each Module, Driving a Separate Internal 16-Bit Counter

The module is controlled through two registers: ICxCON1 (Register 13-1) and ICxCON2 (Register 13-2). A general block diagram of the module is shown in Figure 13-1.

## 13.1 General Operating Modes

### 13.1.1 SYNCHRONOUS AND TRIGGER MODES

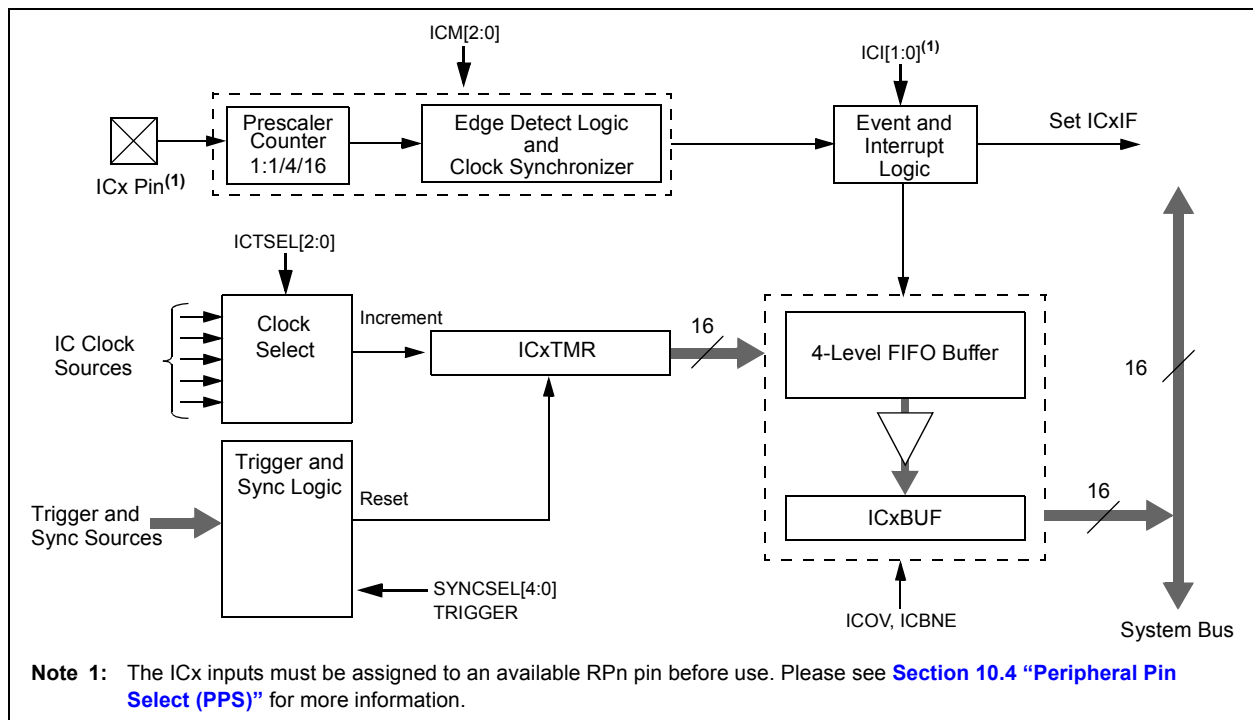
By default, the enhanced input capture module operates in a free-running mode. The internal 16-bit counter ICxTMR counts up continuously, wrapping around from FFFFh to 0000h on each overflow, with its period synchronized to the selected external clock source. When a capture event occurs, the current 16-bit value of the internal counter is written to the FIFO buffer.

In Synchronous mode, the module begins capturing events on the ICx pin as soon as its selected clock source is enabled. Whenever an event occurs on the selected sync source, the internal counter is reset. In Trigger mode, the module waits for a Sync event from another internal module to occur before allowing the internal counter to run.

Standard, free-running operation is selected by setting the SYNCSELx bits to ‘00000’ and clearing the ICTRIG bit (ICxCON2[7]). Synchronous and Trigger modes are selected any time the SYNCSELx bits are set to any value except ‘00000’. The ICTRIG bit selects either Synchronous or Trigger mode; setting the bit selects Trigger mode operation. In both modes, the SYNCSELx bits determine the sync/trigger source.

When the SYNCSELx bits are set to ‘00000’ and ICTRIG is set, the module operates in Software Trigger mode. In this case, capture operations are started by manually setting the TRIGSTAT bit (ICxCON2[6]).

**FIGURE 13-1: INPUT CAPTURE BLOCK DIAGRAM**



# PIC24FJ256GA110 FAMILY

## 13.1.2 CASCADED (32-BIT) MODE

By default, each module operates independently with its own 16-bit timer. To increase resolution, adjacent even and odd modules can be configured to function as a single 32-bit module. (For example, Modules 1 and 2 are paired, as are Modules 3 and 4, and so on.) The odd numbered module (ICx) provides the Least Significant 16 bits of the 32-bit register pairs and the even module (ICy) provides the Most Significant 16 bits. Wraparounds of the ICx registers cause an increment of their corresponding ICy registers.

Cascaded operation is configured in hardware by setting the IC32 bits (ICxCON2[8]) for both modules.

## 13.2 Capture Operations

The enhanced input capture module can be configured to capture timer values and generate interrupts on rising edges on ICx, or all transitions on ICx. Captures can be configured to occur on all rising edges or just some (every 4th or 16th). Interrupts can be independently configured to generate on each event or a subset of events.

To set up the module for capture operations:

1. Configure the ICx input for one of the available Peripheral Pin Select pins.
2. If Synchronous mode is to be used, disable the sync source before proceeding.
3. Make sure that any previous data have been removed from the FIFO by reading ICxBUF until the ICBNE bit (ICxCON1[3]) is cleared.
4. Set the SYNCSELx bits (ICxCON2[4:0]) to the desired sync/trigger source.
5. Set the ICTSELx bits (ICxCON1[12:10]) for the desired clock source.
6. Set the ICIX bits (ICxCON1[6:5]) to the desired interrupt frequency.
7. Select Synchronous or Trigger mode operation:
  - a) Check that the SYNCSELx bits are not set to '00000'.
  - b) For Synchronous mode, clear the ICTRIG bit (ICxCON2[7]).
  - c) For Trigger mode, set ICTRIG and clear the TRIGSTAT bit (ICxCON2[6]).
8. Set the ICMx bits (ICxCON1[2:0]) to the desired operational mode.
9. Enable the selected trigger/sync source.

For 32-bit cascaded operations, the setup procedure is slightly different:

1. Set the IC32 bits for both modules (ICyCON2[8] and (ICxCON2[8]), enabling the even numbered module first. This ensures the modules will start functioning in unison.
2. Set the ICTSELx and SYNCSELx bits for both modules to select the same sync/trigger and time base source. Set the even module first, then the odd module. Both modules must use the same ICTSELx and SYNCSELx settings.
3. Clear the ICTRIG bit of the even module (ICyCON2[7]); this forces the module to run in Synchronous mode with the odd module, regardless of its trigger setting.
4. Use the odd module's ICIX bits (ICxCON1[6:5]) to the desired interrupt frequency.
5. Use the ICTRIG bit of the odd module (ICxCON2[7]) to configure Trigger or Synchronous mode operation.

**Note:** For Synchronous mode operation, enable the sync source as the last step. Both input capture modules are held in Reset until the sync source is enabled.

6. Use the ICMx bits of the odd module (ICxCON1[2:0]) to set the desired capture mode.

The module is ready to capture events when the time base and the trigger/sync source are enabled. When the ICBNE bit (ICxCON1[3]) becomes set, at least one capture value is available in the FIFO. Read input capture values from the FIFO until the ICBNE clears to '0'.

For 32-bit operation, read both the ICxBUF and ICyBUF for the full 32-bit timer value (ICxBUF for the lsw, ICyBUF for the msw). At least one capture value is available in the FIFO buffer when the odd module's ICBNE bit (ICxCON1[3]) becomes set. Continue to read the buffer registers until ICBNE is cleared (perform automatically by hardware).

# PIC24FJ256GA110 FAMILY

**REGISTER 13-1: ICxCON1: INPUT CAPTURE x CONTROL REGISTER 1**

U-0	U-0	R/W-0	R/W-0	R/W-0	R/W-0	U-0	U-0
—	—	ICSIDL	ICTSEL2	ICTSEL1	ICTSEL0	—	—
bit 15						bit 8	

U-0	R/W-0	R/W-0	HCS/R-0	HCS/R-0	R/W-0	R/W-0	R/W-0
—	ICI1	ICI0	ICOV	ICBNE	ICM2 <sup>(1)</sup>	ICM1 <sup>(1)</sup>	ICM0 <sup>(1)</sup>
bit 7						bit 0	

<b>Legend:</b>	HCS = Hardware Clearable/Settable bit		
R = Readable bit	W = Writable bit	U = Unimplemented bit, read as '0'	
-n = Value at POR	'1' = Bit is set	'0' = Bit is cleared	x = Bit is unknown

bit 15-14 **Unimplemented:** Read as '0'

bit 13 **ICSIDL:** Input Capture x Module Stop in Idle Control bit  
 1 = Input capture module halts in CPU Idle mode  
 0 = Input capture module continues to operate in CPU Idle mode

bit 12-10 **ICTSEL[2:0]:** Input Capture Timer Select bits  
 111 = System clock ( $F_{OSC}/2$ )  
 110 = Reserved  
 101 = Reserved  
 100 = Timer1  
 011 = Timer5  
 010 = Timer4  
 001 = Timer2  
 000 = Timer3

bit 9-7 **Unimplemented:** Read as '0'

bit 6-5 **ICI[1:0]:** Select Number of Captures per Interrupt bits  
 11 = Interrupt on every fourth capture event  
 10 = Interrupt on every third capture event  
 01 = Interrupt on every second capture event  
 00 = Interrupt on every capture event

bit 4 **ICOV:** Input Capture x Overflow Status Flag bit (read-only)  
 1 = Input capture overflow occurred  
 0 = No input capture overflow occurred

bit 3 **ICBNE:** Input Capture x Buffer Empty Status bit (read-only)  
 1 = Input capture buffer is not empty, at least one more capture value can be read  
 0 = Input capture buffer is empty

bit 2-0 **ICM[2:0]:** Input Capture Mode Select bits<sup>(1)</sup>  
 111 = Interrupt mode: Input capture functions as interrupt pin only when device is in Sleep or Idle mode (rising edge detect only, all other control bits are not applicable)  
 110 = Unused (module disabled)  
 101 = Prescaler Capture mode: Capture on every 16th rising edge  
 100 = Prescaler Capture mode: Capture on every 4th rising edge  
 011 = Simple Capture mode: Capture on every rising edge  
 010 = Simple Capture mode: Capture on every falling edge  
 001 = Edge Detect Capture mode: Capture on every edge (rising and falling), ICI[1:0] bits do not control interrupt generation for this mode  
 000 = Input capture module turned off

**Note 1:** The ICx input must also be configured to an available RPN pin. For more information, see [Section 10.4 "Peripheral Pin Select \(PPS\)"](#).

# PIC24FJ256GA110 FAMILY

## REGISTER 13-2: ICxCON2: INPUT CAPTURE x CONTROL REGISTER 2

U-0	U-0	U-0	U-0	U-0	U-0	U-0	R/W-0
—	—	—	—	—	—	—	IC32
bit 15							bit 8

R/W-0	HS/R/W-0	U-0	R/W-0	R/W-1	R/W-1	R/W-0	R/W-1
ICTRIG	TRIGSTAT	—	SYNCSEL4	SYNCSEL3	SYNCSEL2	SYNCSEL1	SYNCSEL0
bit 7							bit 0

<b>Legend:</b>	HS = Hardware Settable bit
R = Readable bit	W = Writable bit
-n = Value at POR	'1' = Bit is set
	U = Unimplemented bit, read as '0'
	'0' = Bit is cleared
	x = Bit is unknown

- bit 15-9 **Unimplemented:** Read as '0'
- bit 8 **IC32:** Cascade Two IC Modules Enable bit (32-bit operation)
  - 1 = ICx and ICy operate in cascade as a 32-bit module (this bit must be set in both modules)
  - 0 = ICx functions independently as a 16-bit module
- bit 7 **ICTRIG:** ICx Trigger/Sync Select bit
  - 1 = Triggers ICx from source designated by SYNCSELx bits
  - 0 = Synchronizes ICx with source designated by SYNCSELx bits
- bit 6 **TRIGSTAT:** Timer Trigger Status bit
  - 1 = Timer source has been triggered and is running (set in hardware, can be set in software)
  - 0 = Timer source has not been triggered and is being held clear
- bit 5 **Unimplemented:** Read as '0'
- bit 4-0 **SYNCSEL[4:0]:** Trigger/Synchronization Source Selection bits
  - 11111 = Reserved
  - 11110 = Input Capture 9
  - 11101 = Input Capture 6
  - 11100 = CTMU<sup>(1)</sup>
  - 11011 = A/D<sup>(1)</sup>
  - 11010 = Comparator 3<sup>(1)</sup>
  - 11001 = Comparator 2<sup>(1)</sup>
  - 11000 = Comparator 1<sup>(1)</sup>
  - 10111 = Input Capture 4
  - 10110 = Input Capture 3
  - 10101 = Input Capture 2
  - 10100 = Input Capture 1
  - 10011 = Input Capture 8
  - 10010 = Input Capture 7
  - 1000x = reserved
  - 01111 = Timer5
  - 01110 = Timer4
  - 01101 = Timer3
  - 01100 = Timer2
  - 01011 = Timer1
  - 01010 = Input Capture 5
  - 01001 = Output Compare 9
  - 01000 = Output Compare 8
  - 00111 = Output Compare 7
  - 00110 = Output Compare 6
  - 00101 = Output Compare 5
  - 00100 = Output Compare 4
  - 00011 = Output Compare 3
  - 00010 = Output Compare 2
  - 00001 = Output Compare 1
  - 00000 = Not synchronized to any other module

**Note 1:** Use these inputs as trigger sources only and never as sync sources.

## 14.0 OUTPUT COMPARE WITH DEDICATED TIMER

**Note:** This data sheet summarizes the features of this group of PIC24F devices. It is not intended to be a comprehensive reference source. For more information, refer to “**Output Compare with Dedicated Timer**” ([www.microchip.com/DS70005159](http://www.microchip.com/DS70005159)) in the “*dsPIC33/PIC24 Family Reference Manual*”. The information in this data sheet supersedes the information in the FRM.

Devices in the PIC24FJ256GA110 family all feature nine independent enhanced output compare modules. Each of these modules offers a wide range of configuration and operating options for generating pulse trains on internal device events, and can produce Pulse-Width Modulated (PWM) waveforms for driving power applications.

Key features of the enhanced output compare module include:

- Hardware-Configurable for 32-Bit Operation in All modes by cAscading Two Adjacent Modules
- Synchronous and Trigger modes of Output Compare Operation, with Up to 30 User-Selectable Trigger/Sync Sources Available
- Two Separate Period Registers (a main register, OCxR, and a secondary register, OCxRS) for Greater Flexibility in Generating Pulses of Varying Widths
- Configurable for Single Pulse or Continuous Pulse Generation on an Output Event, or Continuous PWM Waveform Generation
- Up to Six Clock Sources Available for Each Module, Driving a Separate Internal 16-Bit Counter

## 14.1 General Operating Modes

### 14.1.1 SYNCHRONOUS AND TRIGGER MODES

By default, the enhanced output compare module operates in a Free-Running mode. The internal, 16-bit counter, OCxTMR, counts up continuously, wrapping around from FFFFh to 0000h on each overflow, with its period synchronized to the selected external clock source. Compare or PWM events are generated each time a match between the internal counter and one of the Period registers occurs.

In Synchronous mode, the module begins performing its compare or PWM operation as soon as its selected clock source is enabled. Whenever an event occurs on the selected sync source, the module's internal counter is reset. In Trigger mode, the module waits for a sync event from another internal module to occur before allowing the counter to run.

Free-running mode is selected by default, or any time that the SYNCSELx bits (OCxCON2[4:0]) are set to '00000'. Synchronous or Trigger modes are selected any time the SYNCSELx bits are set to any value except '00000'. The OCTRIG bit (OCxCON2[7]) selects either Synchronous or Trigger mode; setting the bit selects Trigger mode operation. In both modes, the SYNCSELx bits determine the sync/trigger source.

### 14.1.2 CASCADED (32-BIT) MODE

By default, each module operates independently with its own set of 16-Bit Timer and Duty Cycle registers. To increase resolution, adjacent even and odd modules can be configured to function as a single 32-bit module. (For example, Modules 1 and 2 are paired, as are Modules 3 and 4, and so on.) The odd numbered module (OCx) provides the Least Significant 16 bits of the 32-bit register pairs, and the even module (OCy) provides the Most Significant 16 bits. Wraparounds of the OCx registers cause an increment of their corresponding OCy registers.

Cascaded operation is configured in hardware by setting the OC32 bits (OCxCON2[8]) for both modules.

# PIC24FJ256GA110 FAMILY

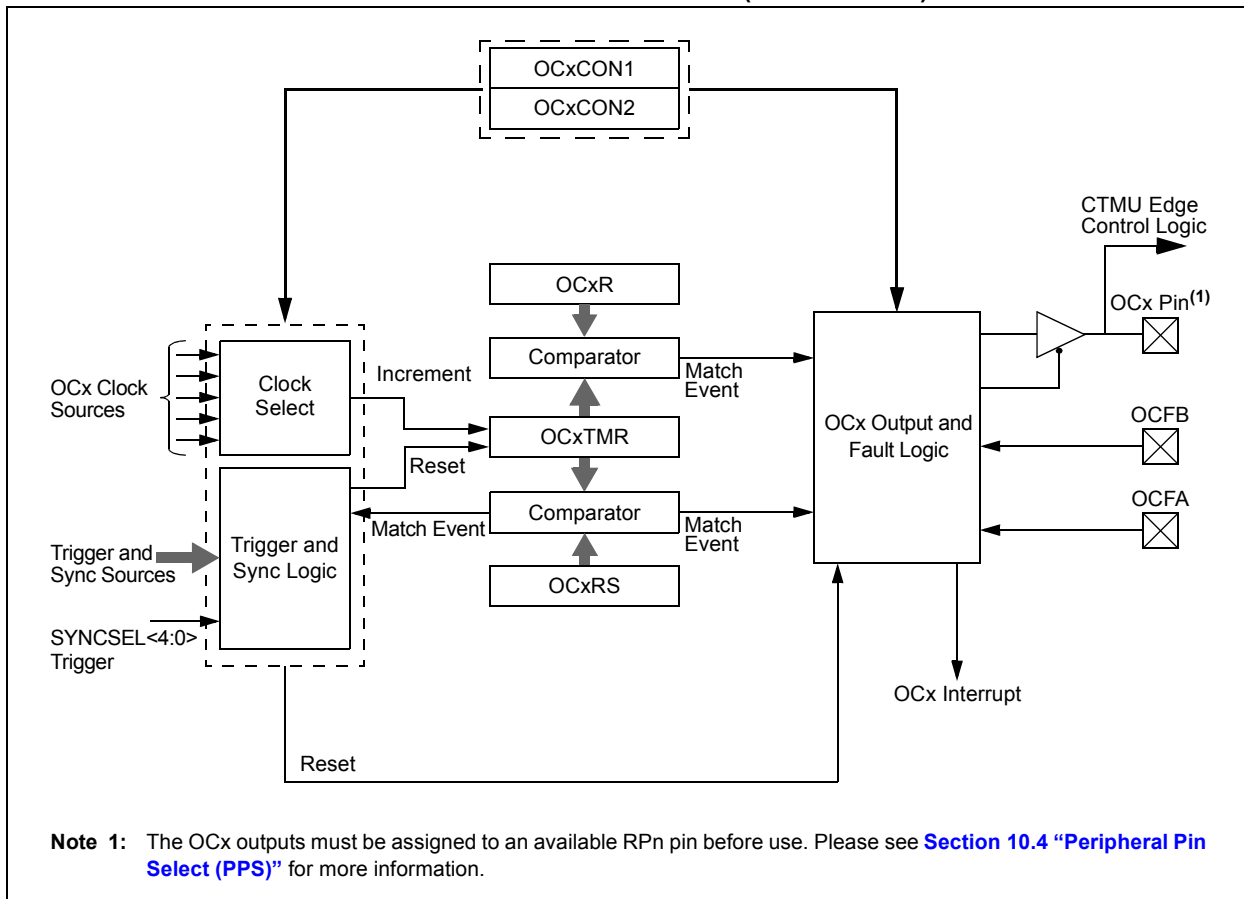
## 14.2 Compare Operations

In Compare mode (Figure 14-1), the enhanced output compare module can be configured for single-shot or continuous pulse generation; it can also repeatedly toggle an output pin on each timer event.

To set up the module for compare operations:

1. Configure the OCx output for one of the available Peripheral Pin Select pins.
2. Calculate the required values for the OCxR and (for Double Compare modes) OCxRS duty cycle registers:
  - a) Determine the instruction clock cycle time. Take into account the frequency of the external clock to the timer source (if one is used) and the timer prescaler settings.
  - b) Calculate time to the rising edge of the output pulse relative to the timer start value (0000h).
  - c) Calculate the time to the falling edge of the pulse based on the desired pulse width and the time to the rising edge of the pulse.
3. Write the rising edge value to OCxR, and the falling edge value to OCxRS.
4. Set the Timer Period register, PRy, to a value equal to or greater than the value in OCxRS.
5. Set the OCM[2:0] bits for the appropriate compare operation (= 0xx).
6. For Trigger mode operations, set OCTRIG to enable Trigger mode. Set or clear TRIGMODE to configure trigger operation, and TRIGSTAT to select a hardware or software trigger. For Synchronous mode, clear OCTRIG.
7. Set the SYNCSEL[4:0] bits to configure the trigger or synchronization source. If free-running timer operation is required, set the SYNCSELx bits to '00000' (no sync/trigger source).
8. Select the time base source with the OCTSEL[2:0] bits. If necessary, set the TON bit for the selected timer which enables the compare time base to count. Synchronous mode operation starts as soon as the time base is enabled; Trigger mode operation starts after a trigger source event occurs.

**FIGURE 14-1: OUTPUT COMPARE BLOCK DIAGRAM (16-BIT MODE)**



# PIC24FJ256GA110 FAMILY

For 32-bit cascaded operation, these steps are also necessary:

1. Set the OC32 bits for both registers (OCyCON2[8] and OCxCON2[8]). Enable the even numbered module first to ensure the modules will start functioning in unison.
2. Clear the OCTRIG bit of the even module (OCyCON2[7]), so the module will run in Synchronous mode.
3. Configure the desired output and Fault settings for OCyCON2.
4. Force the output pin for OCx to the output state by clearing the OCTRIS bit.
5. If Trigger mode operation is required, configure the trigger options in OCx by using the OCTRIG (OCxCON2[7]), TRIGSTAT (OCxCON2[6]) and SYNCSELx (OCxCON2[4:0]) bits.
6. Configure the desired Compare or PWM mode of operation (OCM[2:0]) for OCyCON1 first, then for OCxCON1.

Depending on the output mode selected, the module holds the OCx pin in its default state and forces a transition to the opposite state when OCxR matches the timer. In Double Compare modes, OCx is forced back to its default state when a match with OCxRS occurs. The OCxIF interrupt flag is set after an OCxR match in Single Compare modes, and after each OCxRS match in Double Compare modes.

Single-shot pulse events only occur once, but may be repeated by simply rewriting the value of the OCxCON1 register. Continuous pulse events continue indefinitely until terminated.

## 14.3 Pulse-Width Modulation (PWM) Mode

In PWM mode, the enhanced output compare module can be configured for edge-aligned or center-aligned pulse waveform generation. All PWM operations are double-buffered (buffer registers are internal to the module and are not mapped into SFR space).

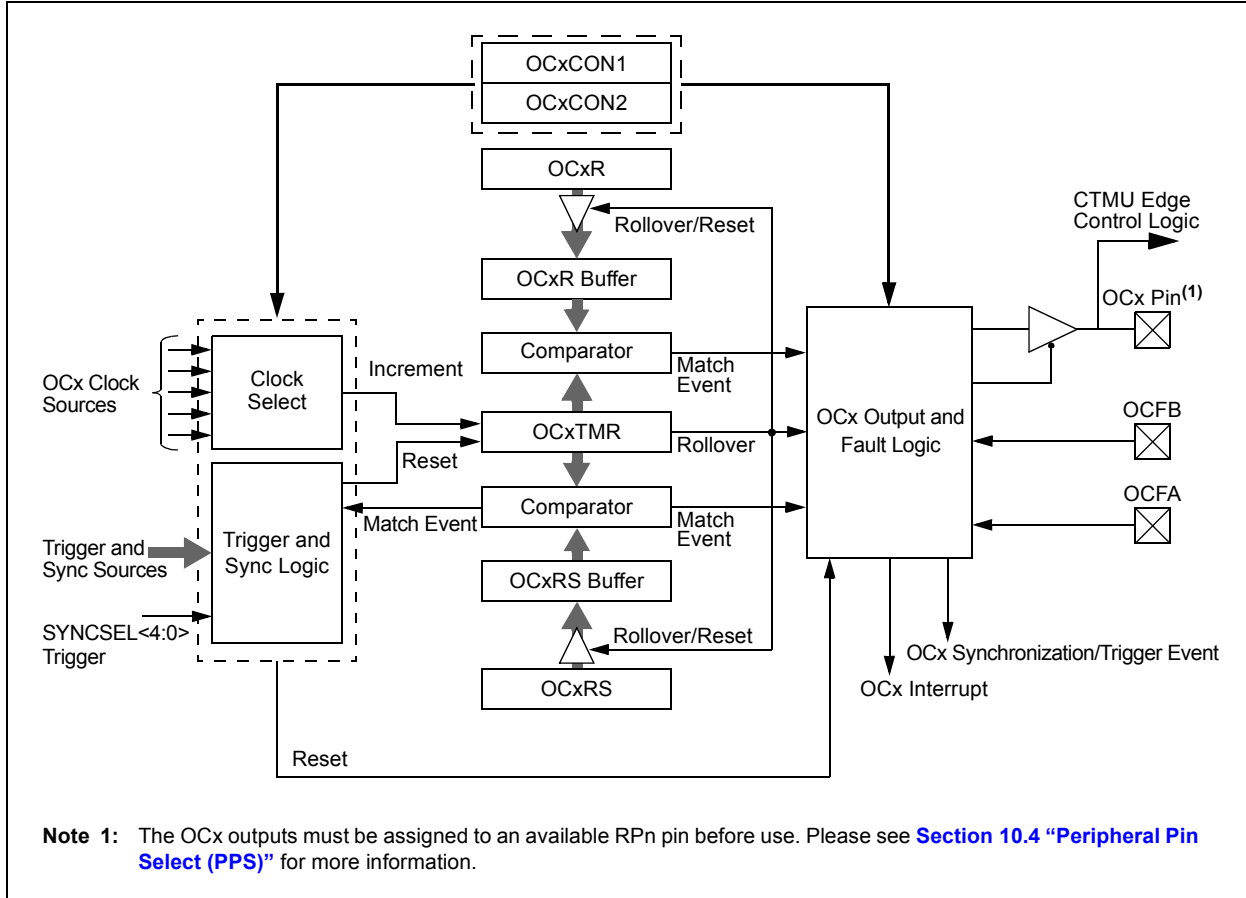
To set up the module for PWM operations:

1. Configure the OCx output for one of the available Peripheral Pin Select pins.
2. Calculate the desired duty cycles and load them into the OCxR register.
3. Calculate the desired period and load it into the OCxRS register.
4. Select the current OCx as the synchronization source by writing 0x1F to SYNCSEL[4:0] (OCxCON2[4:0]) and clearing OCTRIG (OCxCON2[7]).
5. Select a clock source by writing to the OCTSEL2[2:0] (OCxCON[12:10]) bits.
6. Enable interrupts, if required, for the timer and output compare modules. The output compare interrupt is required for PWM Fault pin utilization.
7. Select the desired PWM mode in the OCM[2:0] (OCxCON1[2:0]) bits.
8. If a timer is selected as a clock source, set the TMRy prescale value and enable the time base by setting the TON (TxCON[15]) bit.

**Note:** This peripheral contains input and output functions that may need to be configured by the Peripheral Pin Select. See [Section 10.4 “Peripheral Pin Select \(PPS\)”](#) for more information.

# PIC24FJ256GA110 FAMILY

FIGURE 14-2: OUTPUT COMPARE BLOCK DIAGRAM (DOUBLE-BUFFERED, 16-BIT PWM MODE)



## 14.3.1 PWM PERIOD

The PWM period is specified by writing to PRy, the Timer Period register. The PWM period can be calculated using [Equation 14-1](#).

### EQUATION 14-1: CALCULATING THE PWM PERIOD<sup>(1)</sup>

$$\text{PWM Period} = [(PRy) + 1] \cdot T_{CY} \cdot (\text{Timer Prescale Value})$$

where: PWM Frequency = 1/[PWM Period]

**Note 1:** Based on  $T_{CY} = T_{OSC} \cdot 2$ ; Doze mode and PLL are disabled.

**Note:** A PRy value of N will produce a PWM period of N + 1 time base count cycles. For example, a value of 7 written into the PRy register will yield a period consisting of 8 time base cycles.

## 14.3.2 PWM DUTY CYCLE

The PWM duty cycle is specified by writing to the OCxRS and OCxR registers. The OCxRS and OCxR registers can be written to at any time, but the duty cycle value is not latched until a match between PRy and TMRy occurs (i.e., the period is complete). This provides a double buffer for the PWM duty cycle and is essential for glitchless PWM operation.

Some important boundary parameters of the PWM duty cycle include:

- If OCxR, OCxRS and PRy are all loaded with 0000h, the OCx pin will remain low (0% duty cycle).
- If OCxRS is greater than PRy, the pin will remain high (100% duty cycle).

See [Example 14-1](#) for PWM mode timing details. [Table 14-1](#) and [Table 14-2](#) show example PWM frequencies and resolutions for a device operating at 4 MIPS and 10 MIPS, respectively.

# PIC24FJ256GA110 FAMILY

## EQUATION 14-2: CALCULATION FOR MAXIMUM PWM RESOLUTION<sup>(1)</sup>

$$\text{Maximum PWM Resolution (bits)} = \frac{\log_{10}\left(\frac{F_{CY}}{F_{PWM} \cdot (\text{Timer Prescale Value})}\right)}{\log_{10}(2)} \text{ bits}$$

**Note 1:** Based on  $F_{CY} = F_{OSC}/2$ ; Doze mode and PLL are disabled.

## EXAMPLE 14-1: PWM PERIOD AND DUTY CYCLE CALCULATIONS<sup>(1)</sup>

- Find the Timer Period register value for a desired PWM frequency of 52.08 kHz, where  $F_{OSC} = 8$  MHz with PLL (32 MHz device clock rate) and a Timer2 prescaler setting of 1:1.
  - $T_{CY} = 2 * T_{OSC} = 62.5$  ns
  - PWM Period =  $1/\text{PWM Frequency} = 1/52.08$  kHz = 19.2  $\mu$ s
  - PWM Period =  $(PR2 + 1) \cdot T_{CY} \cdot (\text{Timer2 Prescale Value})$
  - 19.2  $\mu$ s =  $(PR2 + 1) \cdot 62.5$  ns  $\cdot$  1
  - PR2 = 306
- Find the maximum resolution of the duty cycle that can be used with a 52.08 kHz frequency and a 32 MHz device clock rate:
  - PWM Resolution =  $\log_{10}(F_{CY}/F_{PWM})/\log_{10}(2)$  bits
  - =  $(\log_{10}(16$  MHz/52.08 kHz)/ $\log_{10}(2))$  bits
  - = 8.3 bits

**Note 1:** Based on  $T_{CY} = 2 * T_{OSC}$ ; Doze mode and PLL are disabled.

**TABLE 14-1: EXAMPLE PWM FREQUENCIES AND RESOLUTIONS AT 4 MIPS ( $F_{CY} = 4$  MHz)<sup>(1)</sup>**

PWM Frequency	7.6 Hz	61 Hz	122 Hz	977 Hz	3.9 kHz	31.3 kHz	125 kHz
Timer Prescaler Ratio	8	1	1	1	1	1	1
Period Register Value	FFFFh	FFFFh	7FFFh	0FFFh	03FFh	007Fh	001Fh
Resolution (bits)	16	16	15	12	10	7	5

**Note 1:** Based on  $F_{CY} = F_{OSC}/2$ ; Doze mode and PLL are disabled.

**TABLE 14-2: EXAMPLE PWM FREQUENCIES AND RESOLUTIONS AT 16 MIPS ( $F_{CY} = 16$  MHz)<sup>(1)</sup>**

PWM Frequency	30.5 Hz	244 Hz	488 Hz	3.9 kHz	15.6 kHz	125 kHz	500 kHz
Timer Prescaler Ratio	8	1	1	1	1	1	1
Period Register Value	FFFFh	FFFFh	7FFFh	0FFFh	03FFh	007Fh	001Fh
Resolution (bits)	16	16	15	12	10	7	5

**Note 1:** Based on  $F_{CY} = F_{OSC}/2$ ; Doze mode and PLL are disabled.

# PIC24FJ256GA110 FAMILY

## REGISTER 14-1: OCxCON1: OUTPUT COMPARE x CONTROL 1 REGISTER

U-0	U-0	R/W-0	R/W-0	R/W-0	R/W-0	U-0	U-0
—	—	OCSIDL	OCTSEL2	OCTSEL1	OCTSEL0	—	—
bit 15						bit 8	

R/W-0	U-0	U-0	HCS/R/W-0	R/W-0	R/W-0	R/W-0	R/W-0
ENFLT0	—	—	OCFLT0	TRIGMODE	OCM2 <sup>(1)</sup>	OCM1 <sup>(1)</sup>	OCM0 <sup>(1)</sup>
bit 7						bit 0	

<b>Legend:</b>	HCS = Hardware Clearable/Settable bit						
R = Readable bit	W = Writable bit		U = Unimplemented bit, read as '0'				
-n = Value at POR	'1' = Bit is set		'0' = Bit is cleared		x = Bit is unknown		

bit 15-14 **Unimplemented:** Read as '0'

bit 13 **OCSIDL:** Stop Output Compare x in Idle Mode Control bit  
 1 = Output Compare x halts in CPU Idle mode  
 0 = Output Compare x continues to operate in CPU Idle mode

bit 12-10 **OCTSEL[2:0]:** Output Compare x Timer Select bits  
 111 = Peripheral clock (FCY)  
 110 = Reserved  
 101 = Reserved  
 100 = Timer1  
 011 = Timer5  
 010 = Timer4  
 001 = Timer3  
 000 = Timer2

bit 9-8 **Unimplemented:** Read as '0'

bit 7 **ENFLT0:** Fault 0 Input Enable bit  
 1 = Fault 0 input is enabled  
 0 = Fault 0 input is disabled

bit 6-5 **Unimplemented:** Read as '0'

bit 4 **OCFLT0:** PWM Fault Condition Status bit  
 1 = PWM Fault condition has occurred (cleared in HW only)  
 0 = No PWM Fault condition has occurred (this bit is only used when OCM[2:0] = 111)

bit 3 **TRIGMODE:** Trigger Status Mode Select bit  
 1 = TRIGSTAT (OCxCON2[6]) is cleared when OCxRS = OCxTMR or in software  
 0 = TRIGSTAT is only cleared by software

bit 2-0 **OCM[2:0]:** Output Compare x Mode Select bits<sup>(1)</sup>  
 111 = Center-Aligned PWM mode on OCx<sup>(2)</sup>  
 110 = Edge-Aligned PWM mode on OCx<sup>(2)</sup>  
 101 = Double Compare Continuous Pulse mode: initialize OCx pin low, toggle OCx state continuously on alternate matches of OCxR and OCxRS  
 100 = Double Compare Single-Shot mode: initialize OCx pin low, toggle OCx state on matches of OCxR and OCxRS for one cycle  
 011 = Single Compare Continuous Pulse mode: compare events continuously toggle OCx pin  
 010 = Single Compare Single-Shot mode: initialize OCx pin high, compare event forces OCx pin low  
 001 = Single Compare Single-Shot mode: initialize OCx pin low, compare event forces OCx pin high  
 000 = Output compare channel is disabled

**Note 1:** The OCx output must also be configured to an available RPN pin. For more information, see [Section 10.4 "Peripheral Pin Select \(PPS\)"](#).

**2:** OCFA pin controls OC1-OC4 channels; OCFB pin controls the OC5-OC9 channels. OCxR and OCxRS are double-buffered only in PWM modes.

# PIC24FJ256GA110 FAMILY

## REGISTER 14-2: OCxCON2: OUTPUT COMPARE x CONTROL 2 REGISTER

R/W-0	R/W-0	R/W-0	R/W-0	U-0	U-0	U-0	R/W-0
FLTMD	FLTOUT	FLTTRIEN	OCINV	—	—	—	OC32
bit 15							bit 8

R/W-0	HS/R/W-0	R/W-0	R/W-0	R/W-1	R/W-1	R/W-0	R/W-0
OCTRIG	TRIGSTAT	OCTRIS	SYNCSEL4	SYNCSEL3	SYNCSEL2	SYNCSEL1	SYNCSEL0
bit 7							bit 0

<b>Legend:</b>	HS = Hardware Settable bit
R = Readable bit	W = Writable bit
-n = Value at POR	'1' = Bit is set
	U = Unimplemented bit, read as '0'
	'0' = Bit is cleared
	x = Bit is unknown

- bit 15     **FLTMD:** Fault Mode Select bit  
 1 = Fault mode is maintained until the Fault source is removed and the corresponding OCFLT0 bit is cleared in software  
 0 = Fault mode is maintained until the Fault source is removed and a new PWM period starts
- bit 14     **FLTOUT:** Fault Out bit  
 1 = PWM output is driven high on a Fault  
 0 = PWM output is driven low on a Fault
- bit 13     **FLTTRIEN:** Fault Output State Select bit  
 1 = Pin is forced to an output on a Fault condition  
 0 = Pin I/O condition is unaffected by a Fault
- bit 12     **OCINV:** OCMP Invert bit  
 1 = OCx output is inverted  
 0 = OCx output is not inverted
- bit 11-9   **Unimplemented:** Read as '0'
- bit 8       **OC32:** Cascade Two OC Modules Enable bit (32-bit operation)  
 1 = Cascade module operation enabled  
 0 = Cascade module operation disabled
- bit 7       **OCTRIG:** OCx Trigger/Sync Select bit  
 1 = Triggers OCx from source designated by SYNCSELx bits  
 0 = Synchronizes OCx with source designated by SYNCSELx bits
- bit 6       **TRIGSTAT:** Timer Trigger Status bit  
 1 = Timer source has been triggered and is running  
 0 = Timer source has not been triggered and is being held clear
- bit 5       **OCTRIS:** OCx Output Pin Direction Select bit  
 1 = OCx pin is tri-stated  
 0 = Output Compare Peripheral x connected to the OCx pin

- Note 1:** Never use an OC module as its own trigger source, either by selecting this mode or another equivalent SYNCSELx setting.
- 2:** Use these inputs as trigger sources only and never as sync sources.

# PIC24FJ256GA110 FAMILY

---

## REGISTER 14-2: OCxCON2: OUTPUT COMPARE x CONTROL 2 REGISTER (CONTINUED)

bit 4-0      **SYNCSEL[4:0]:** Trigger/Synchronization Source Selection bits

11111 = This OC module<sup>(1)</sup>  
11110 = Input Capture 9<sup>(2)</sup>  
11101 = Input Capture 6<sup>(2)</sup>  
11100 = CTMU<sup>(2)</sup>  
11011 = A/D<sup>(2)</sup>  
11010 = Comparator 3<sup>(2)</sup>  
11001 = Comparator 2<sup>(2)</sup>  
11000 = Comparator 1<sup>(2)</sup>  
10111 = Input Capture 4<sup>(2)</sup>  
10110 = Input Capture 3<sup>(2)</sup>  
10101 = Input Capture 2<sup>(2)</sup>  
10100 = Input Capture 1<sup>(2)</sup>  
10011 = Input Capture 8<sup>(2)</sup>  
10010 = Input Capture 7<sup>(2)</sup>  
1000x = reserved  
01111 = Timer5  
01110 = Timer4  
01101 = Timer3  
01100 = Timer2  
01011 = Timer1  
01010 = Input Capture 5<sup>(2)</sup>  
01001 = Output Compare 9<sup>(1)</sup>  
01000 = Output Compare 8<sup>(1)</sup>  
00111 = Output Compare 7<sup>(1)</sup>  
00110 = Output Compare 6<sup>(1)</sup>  
00101 = Output Compare 5<sup>(1)</sup>  
00100 = Output Compare 4<sup>(1)</sup>  
00011 = Output Compare 3<sup>(1)</sup>  
00010 = Output Compare 2<sup>(1)</sup>  
00001 = Output Compare 1<sup>(1)</sup>  
00000 = Not synchronized to any other module

- Note 1:** Never use an OC module as its own trigger source, either by selecting this mode or another equivalent SYNCSELx setting.
- 2:** Use these inputs as trigger sources only and never as sync sources.

## 15.0 SERIAL PERIPHERAL INTERFACE (SPI)

**Note:** This data sheet summarizes the features of this group of PIC24F devices. It is not intended to be a comprehensive reference source. For more information, refer to “Serial Peripheral Interface (SPI)” ([www.microchip.com/DS70005185](http://www.microchip.com/DS70005185)) in the “dsPIC33/PIC24 Family Reference Manual”. The information in this data sheet supersedes the information in the FRM.

The Serial Peripheral Interface (SPI) module is a synchronous serial interface useful for communicating with other peripheral or microcontroller devices. These peripheral devices may be serial EEPROMs, shift registers, display drivers, A/D Converters, etc. The SPI module is compatible with Motorola® SPI and SIOP interfaces. All devices of the PIC24FJ256GA110 family include three SPI modules.

The module supports operation in two buffer modes. In Standard mode, data are shifted through a single serial buffer. In Enhanced Buffer mode, data are shifted through an 8-level FIFO buffer.

**Note:** Do not perform Read-Modify-Write (RMW) operations (such as bit-oriented instructions) on the SPIxBUF register in either Standard or Enhanced Buffer mode.

The module also supports a basic framed SPI protocol while operating in either Master or Slave mode. A total of four framed SPI configurations are supported.

The SPI serial interface consists of four pins:

- SDIx: Serial Data Input
- SDOx: Serial Data Output
- SCKx: Shift Clock Input or Output
- $\overline{\text{SSx}}$ : Active-Low Slave Select or Frame Synchronization I/O Pulse

The SPI module can be configured to operate using two, three or four pins. In the 3-pin mode,  $\overline{\text{SSx}}$  is not used. In the 2-pin mode, both SDOx and  $\overline{\text{SSx}}$  are not used.

Block diagrams of the module in Standard and Enhanced modes are shown in [Figure 15-1](#) and [Figure 15-2](#).

**Note:** In this section, the SPI modules are referred to together as SPIx or separately as SPI1, SPI2 or SPI3. Special Function Registers will follow a similar notation. For example, SPIxCON1 and SPIxCON2 refer to the control registers for any of the three SPI modules.

# PIC24FJ256GA110 FAMILY

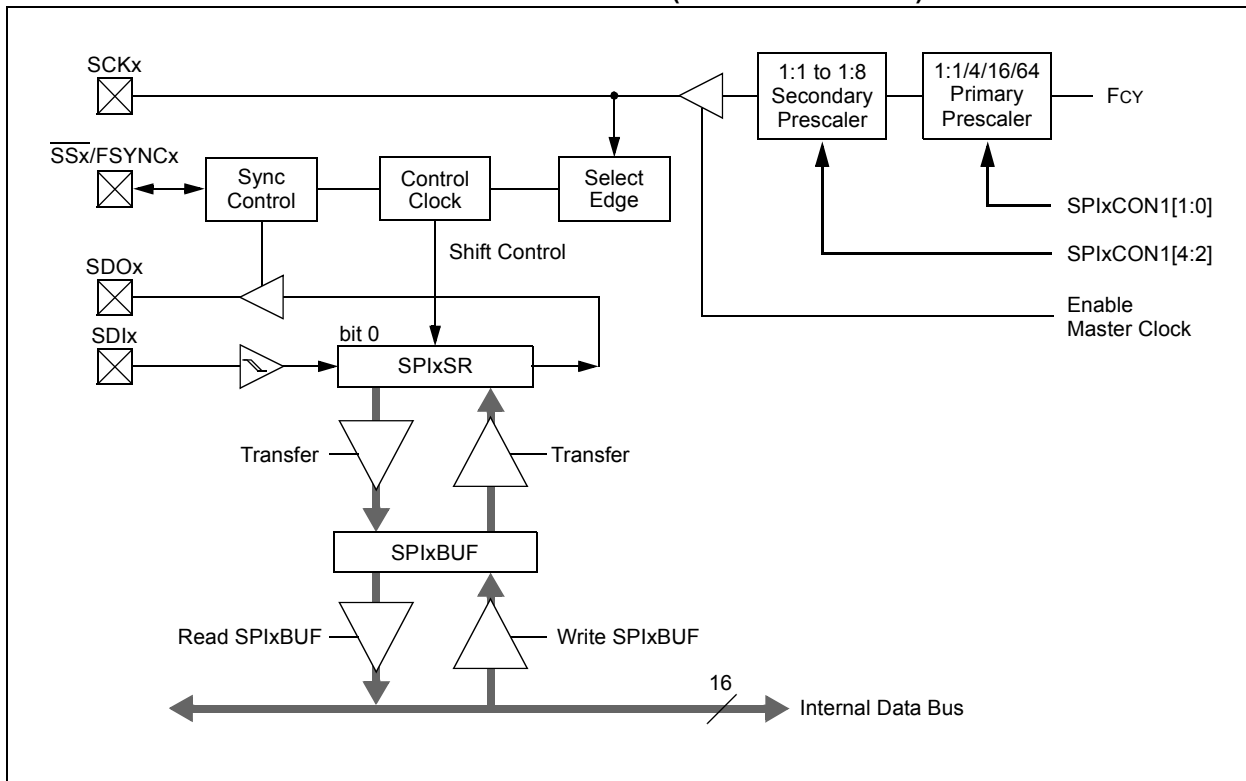
To set up the SPI module for the Standard Master mode of operation:

1. If using interrupts:
  - a) Clear the SPIxIF bit in the respective IFSx register.
  - b) Set the SPIxIE bit in the respective IECx register.
  - c) Write the SPIxIP bits in the respective IPCx register to set the interrupt priority.
2. Write the desired settings to the SPIxCON1 and SPIxCON2 registers with the MSTEN bit (SPIxCON1[5]) = 1.
3. Clear the SPIROV bit (SPIxSTAT[6]).
4. Enable SPI operation by setting the SPIEN bit (SPIxSTAT[15]).
5. Write the data to be transmitted to the SPIxBUF register. Transmission (and reception) will start as soon as data are written to the SPIxBUF register.

To set up the SPI module for the Standard Slave mode of operation:

1. Clear the SPIxBUF register.
2. If using interrupts:
  - a) Clear the SPIxIF bit in the respective IFSx register.
  - b) Set the SPIxIE bit in the respective IECx register.
  - c) Write the SPIxIP bits in the respective IPCx register to set the interrupt priority.
3. Write the desired settings to the SPIxCON1 and SPIxCON2 registers with the MSTEN bit (SPIxCON1[5]) = 0.
4. Clear the SMP bit.
5. If the CKE bit is set, then the SSEN bit (SPIxCON1[8]) must be set to enable the SSx pin.
6. Clear the SPIROV bit (SPIxSTAT[6]).
7. Enable SPI operation by setting the SPIEN bit (SPIxSTAT[15]).

**FIGURE 15-1: SPIx MODULE BLOCK DIAGRAM (STANDARD MODE)**



# PIC24FJ256GA110 FAMILY

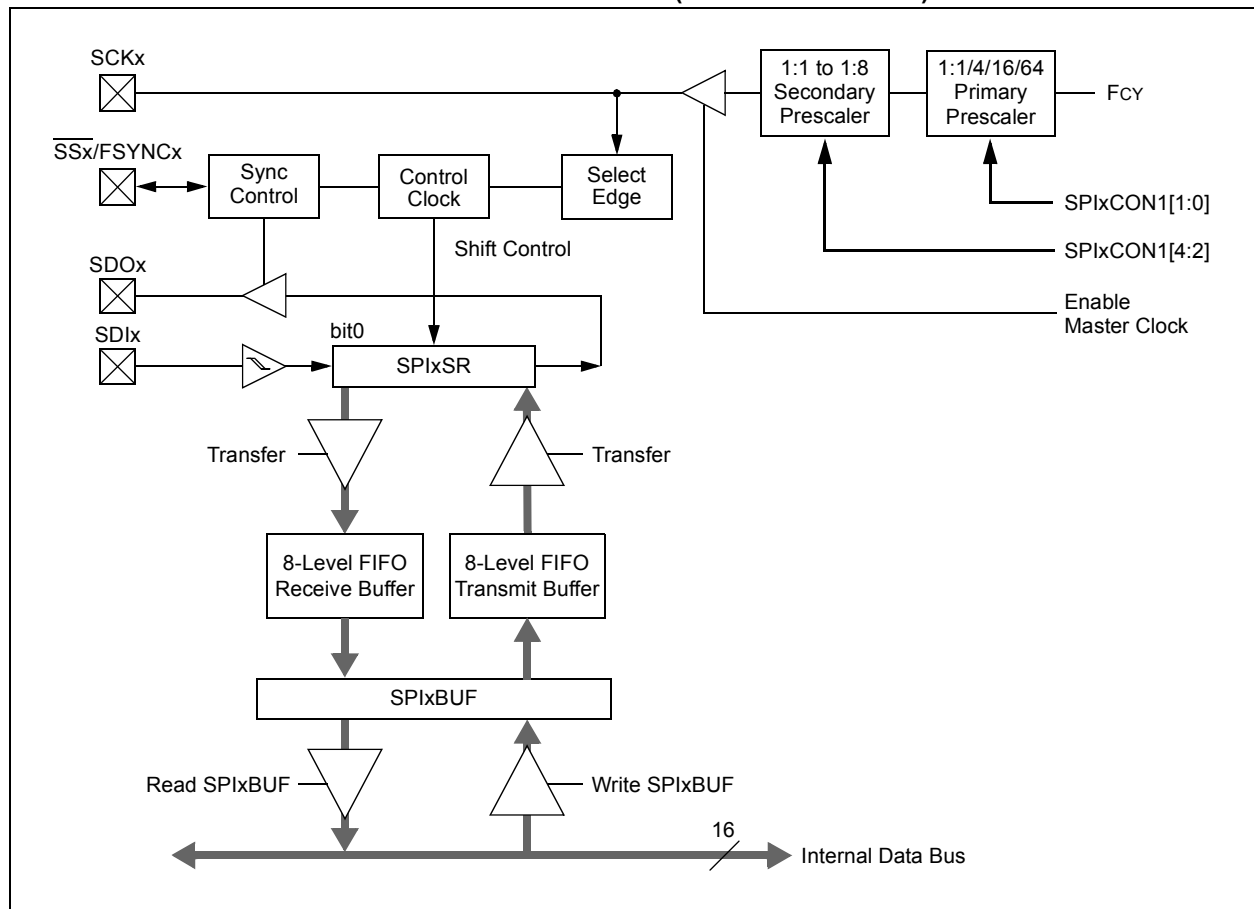
To set up the SPI module for the Enhanced Buffer Master mode of operation:

1. If using interrupts:
  - a) Clear the SPIxIF bit in the respective IFSx register.
  - b) Set the SPIxIE bit in the respective IECx register.
  - c) Write the SPIxIP bits in the respective IPCx register.
2. Write the desired settings to the SPIxCON1 and SPIxCON2 registers with the MSTEN bit (SPIxCON1[5]) = 1.
3. Clear the SPIROV bit (SPIxSTAT[6]).
4. Select Enhanced Buffer mode by setting the SPIBEN bit (SPIxCON2[0]).
5. Enable SPI operation by setting the SPIEN bit (SPIxSTAT[15]).
6. Write the data to be transmitted to the SPIxBUF register. Transmission (and reception) will start as soon as data are written to the SPIxBUF register.

To set up the SPI module for the Enhanced Buffer Slave mode of operation:

1. Clear the SPIxBUF register.
2. If using interrupts:
  - a) Clear the SPIxIF bit in the respective IFSx register.
  - b) Set the SPIxIE bit in the respective IECx register.
  - c) Write the SPIxIP bits in the respective IPCx register to set the interrupt priority.
3. Write the desired settings to the SPIxCON1 and SPIxCON2 registers with the MSTEN bit (SPIxCON1[5]) = 0.
4. Clear the SMP bit.
5. If the CKE bit is set, then the SSx pin must be set, thus enabling the SSx pin.
6. Clear the SPIROV bit (SPIxSTAT[6]).
7. Select Enhanced Buffer mode by setting the SPIBEN bit (SPIxCON2[0]).
8. Enable SPI operation by setting the SPIEN bit (SPIxSTAT[15]).

**FIGURE 15-2: SPIx MODULE BLOCK DIAGRAM (ENHANCED MODE)**



# PIC24FJ256GA110 FAMILY

## REGISTER 15-1: SPIxSTAT: SPIx STATUS AND CONTROL REGISTER

R/W-0	U-0	R/W-0	U-0	U-0	R-0	R-0	R-0
SPIEN <sup>(1)</sup>	—	SPISIDL	—	—	SPIBEC2	SPIBEC1	SPIBEC0
bit 15					bit 8		

R-0	HS/R/C-0	R-0	R/W-0	R/W-0	R/W-0	R-0	R-0
SRMPT	SPIROV	SRXMPT	SISEL2	SISEL1	SISEL0	SPITBF	SPIRBF
bit 7						bit 0	

<b>Legend:</b>	C = Clearable bit	HS = Hardware Settable bit
R = Readable bit	W = Writable bit	U = Unimplemented bit, read as '0'
-n = Value at POR	'1' = Bit is set	'0' = Bit is cleared      x = Bit is unknown

- bit 15      **SPIEN:** SPIx Enable bit<sup>(1)</sup>  
 1 = Enables module and configures SCKx, SDOx, SDIx and  $\overline{SSx}$  as serial port pins  
 0 = Disables module
- bit 14      **Unimplemented:** Read as '0'
- bit 13      **SPISIDL:** Stop in Idle Mode bit  
 1 = Discontinues module operation when device enters Idle mode  
 0 = Continues module operation in Idle mode
- bit 12-11      **Unimplemented:** Read as '0'
- bit 10-8      **SPIBEC[2:0]:** SPIx Buffer Element Count bits (valid in Enhanced Buffer mode)  
Master mode:  
 Number of SPI transfers pending.  
Slave mode:  
 Number of SPI transfers unread.
- bit 7      **SRMPT:** Shift Register (SPIxSR) Empty bit (valid in Enhanced Buffer mode)  
 1 = SPIx Shift register is empty and ready to send or receive  
 0 = SPIx Shift register is not empty
- bit 6      **SPIROV:** Receive Overflow Flag bit  
 1 = A new byte/word is completely received and discarded. The user software has not read the previous data in the SPIxBUF register.  
 0 = No overflow has occurred
- bit 5      **SRXMPT:** Receive FIFO Empty bit (valid in Enhanced Buffer mode)  
 1 = Receive FIFO is empty  
 0 = Receive FIFO is not empty
- bit 4-2      **SISEL[2:0]:** SPIx Buffer Interrupt Mode bits (valid in Enhanced Buffer mode)  
 111 = Interrupt when SPIx transmit buffer is full (SPITBF bit is set)  
 110 = Interrupt when last bit is shifted into SPIxSR; as a result, the TX FIFO is empty  
 101 = Interrupt when the last bit is shifted out of SPIxSR; now the transmit is complete  
 100 = Interrupt when one datum is shifted into the SPIxSR; as a result, the TX FIFO has one open spot  
 011 = Interrupt when SPIx receive buffer is full (SPIRBF bit set)  
 010 = Interrupt when SPIx receive buffer is 3/4 or more full  
 001 = Interrupt when data are available in receive buffer (SRMPT bit is set)  
 000 = Interrupt when the last data in the receive buffer are read; as a result, the buffer is empty (SRXMPT bit set)

**Note 1:** If SPIEN = 1, these functions must be assigned to available RPN pins (or to ASCK1 for the SCK1 output) before use. See [Section 10.4 “Peripheral Pin Select \(PPS\)”](#) for more information.

# PIC24FJ256GA110 FAMILY

---

## REGISTER 15-1: SPIxSTAT: SPIx STATUS AND CONTROL REGISTER (CONTINUED)

- bit 1      **SPITBF:** SPIx Transmit Buffer Full Status bit  
1 = Transmit not yet started, SPIxTXB is full  
0 = Transmit started, SPIxTXB is empty  
In Standard Buffer mode:  
Automatically set in hardware when CPU writes SPIxBUF location, loading SPIxTXB. Automatically cleared in hardware when SPIx module transfers data from SPIxTXB to SPIxSR.  
In Enhanced Buffer mode:  
Automatically set in hardware when CPU writes SPIxBUF location, loading the last available buffer location. Automatically cleared in hardware when a buffer location is available for a CPU write.
- bit 0      **SPIRBF:** SPIx Receive Buffer Full Status bit  
1 = Receive complete, SPIxRXB is full  
0 = Receive is not complete, SPIxRXB is empty  
In Standard Buffer mode:  
Automatically set in hardware when SPIx transfers data from SPIxSR to SPIxRXB. Automatically cleared in hardware when core reads SPIxBUF location, reading SPIxRXB.  
In Enhanced Buffer mode:  
Automatically set in hardware when SPIx transfers data from SPIxSR to buffer, filling the last unread buffer location. Automatically cleared in hardware when a buffer location is available for a transfer from SPIxSR.

**Note 1:** If SPIEN = 1, these functions must be assigned to available RPn pins (or to ASCK1 for the SCK1 output) before use. See [Section 10.4 “Peripheral Pin Select \(PPS\)”](#) for more information.

# PIC24FJ256GA110 FAMILY

## REGISTER 15-2: SPIxCON1: SPIx CONTROL REGISTER 1

U-0	U-0	U-0	R/W-0	R/W-0	R/W-0	R/W-0	R/W-0
—	—	—	DISSCK <sup>(1)</sup>	DISSDO <sup>(2)</sup>	MODE16	SMP	CKE <sup>(3)</sup>
bit 15							bit 8

R/W-0	R/W-0	R/W-0	R/W-0	R/W-0	R/W-0	R/W-0	R/W-0
SSEN <sup>(4)</sup>	CKP	MSTEN	SPRE2	SPRE1	SPRE0	PPRE1	PPRE0
bit 7							bit 0

### Legend:

R = Readable bit                      W = Writable bit                      U = Unimplemented bit, read as '0'  
 -n = Value at POR                      '1' = Bit is set                      '0' = Bit is cleared                      x = Bit is unknown

- bit 15-13      **Unimplemented:** Read as '0'
- bit 12      **DISSCK:** Disable SCKx pin bit (SPI Master modes only)<sup>(1)</sup>  
 1 = Internal SPI clock is disabled; pin functions as I/O  
 0 = Internal SPI clock is enabled
- bit 11      **DISSDO:** Disable SDOx pin bit<sup>(2)</sup>  
 1 = SDOx pin is not used by module; pin functions as I/O  
 0 = SDOx pin is controlled by the module
- bit 10      **MODE16:** Word/Byte Communication Select bit  
 1 = Communication is word-wide (16 bits)  
 0 = Communication is byte-wide (8 bits)
- bit 9      **SMP:** SPIx Data Input Sample Phase bit  
Master mode:  
 1 = Input data sampled at end of data output time  
 0 = Input data sampled at middle of data output time  
Slave mode:  
 SMP must be cleared when SPIx is used in Slave mode.
- bit 8      **CKE:** SPIx Clock Edge Select bit<sup>(3)</sup>  
 1 = Serial output data change on transition from active clock state to Idle clock state (see bit 6)  
 0 = Serial output data change on transition from Idle clock state to active clock state (see bit 6)
- bit 7      **SSEN:** Slave Select Enable (Slave mode) bit<sup>(4)</sup>  
 1 =  $\overline{SSx}$  pin used for Slave mode  
 0 =  $\overline{SSx}$  pin not used by module; pin controlled by port function
- bit 6      **CKP:** Clock Polarity Select bit  
 1 = Idle state for clock is a high level; active state is a low level  
 0 = Idle state for clock is a low level; active state is a high level
- bit 5      **MSTEN:** Master Mode Enable bit  
 1 = Master mode  
 0 = Slave mode

- Note 1:** If DISSCK = 0, SCKx must be configured to an available RPN pin (or to ASCK1 for SPI1). See [Section 10.4 “Peripheral Pin Select \(PPS\)”](#) for more information.
- Note 2:** If DISSDO = 0, SDOx must be configured to an available RPN pin. See [Section 10.4 “Peripheral Pin Select \(PPS\)”](#) for more information.
- Note 3:** The CKE bit is not used in the Framed SPI modes. The user should program this bit to '0' for the Framed SPI modes (FRMEN = 1).
- Note 4:** If SSEN = 1,  $\overline{SSx}$  must be configured to an available RPN pin. See [Section 10.4 “Peripheral Pin Select \(PPS\)”](#) for more information.

# PIC24FJ256GA110 FAMILY

## REGISTER 15-2: SPIxCON1: SPIx CONTROL REGISTER 1 (CONTINUED)

bit 4-2 **SPRE[2:0]:** Secondary Prescale bits (Master mode)

111 = Secondary prescale 1:1  
 110 = Secondary prescale 2:1  
 ...  
 000 = Secondary prescale 8:1

bit 1-0 **PPRE[1:0]:** Primary Prescale bits (Master mode)

11 = Primary prescale 1:1  
 10 = Primary prescale 4:1  
 01 = Primary prescale 16:1  
 00 = Primary prescale 64:1

- Note 1:** If DISSCK = 0, SCKx must be configured to an available RPN pin (or to ASCK1 for SPI1). See [Section 10.4 “Peripheral Pin Select \(PPS\)”](#) for more information.
- 2:** If DISSDO = 0, SDOx must be configured to an available RPN pin. See [Section 10.4 “Peripheral Pin Select \(PPS\)”](#) for more information.
- 3:** The CKE bit is not used in the Framed SPI modes. The user should program this bit to ‘0’ for the Framed SPI modes (FRMEN = 1).
- 4:** If SSEN = 1, SSx must be configured to an available RPN pin. See [Section 10.4 “Peripheral Pin Select \(PPS\)”](#) for more information.

## REGISTER 15-3: SPIxCON2: SPIx CONTROL REGISTER 2

R/W-0	R/W-0	R/W-0	U-0	U-0	U-0	U-0	U-0
FRMEN	SPIFSD	SPIFPOL	—	—	—	—	—
bit 15							bit 8

U-0	U-0	U-0	U-0	U-0	U-0	R/W-0	R/W-0
—	—	—	—	—	—	SPIFE	SPIBEN
bit 7						bit 0	

### Legend:

R = Readable bit                      W = Writable bit                      U = Unimplemented bit, read as ‘0’  
 -n = Value at POR                      ‘1’ = Bit is set                      ‘0’ = Bit is cleared                      x = Bit is unknown

bit 15 **FRMEN:** Framed SPIx Support bit

1 = Framed SPIx support enabled  
 0 = Framed SPIx support disabled

bit 14 **SPIFSD:** Frame Sync Pulse Direction Control on SSx Pin bit

1 = Frame sync pulse input (slave)  
 0 = Frame sync pulse output (master)

bit 13 **SPIFPOL:** Frame Sync Pulse Polarity bit (Frame mode only)

1 = Frame sync pulse is active-high  
 0 = Frame sync pulse is active-low

bit 12-2 **Unimplemented:** Read as ‘0’

bit 1 **SPIFE:** Frame Sync Pulse Edge Select bit

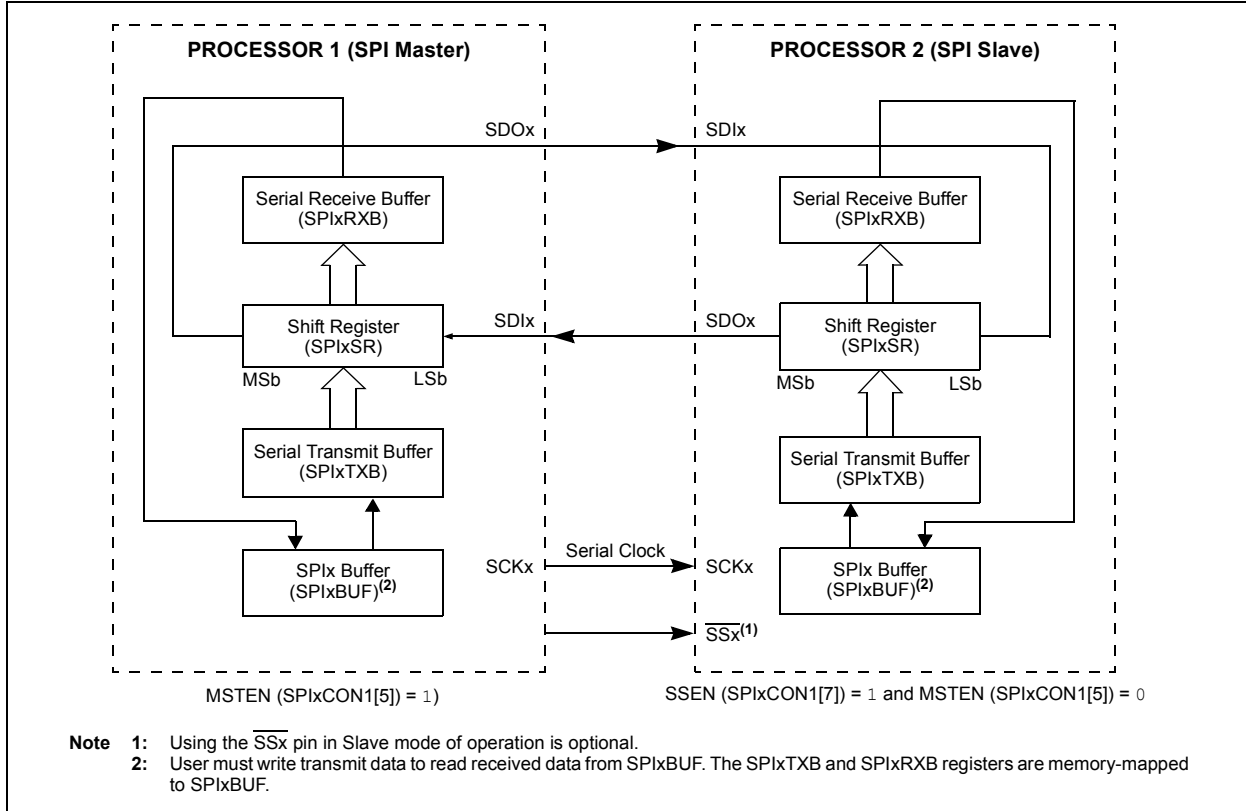
1 = Frame sync pulse coincides with first bit clock  
 0 = Frame sync pulse precedes first bit clock

bit 0 **SPIBEN:** Enhanced Buffer Enable bit

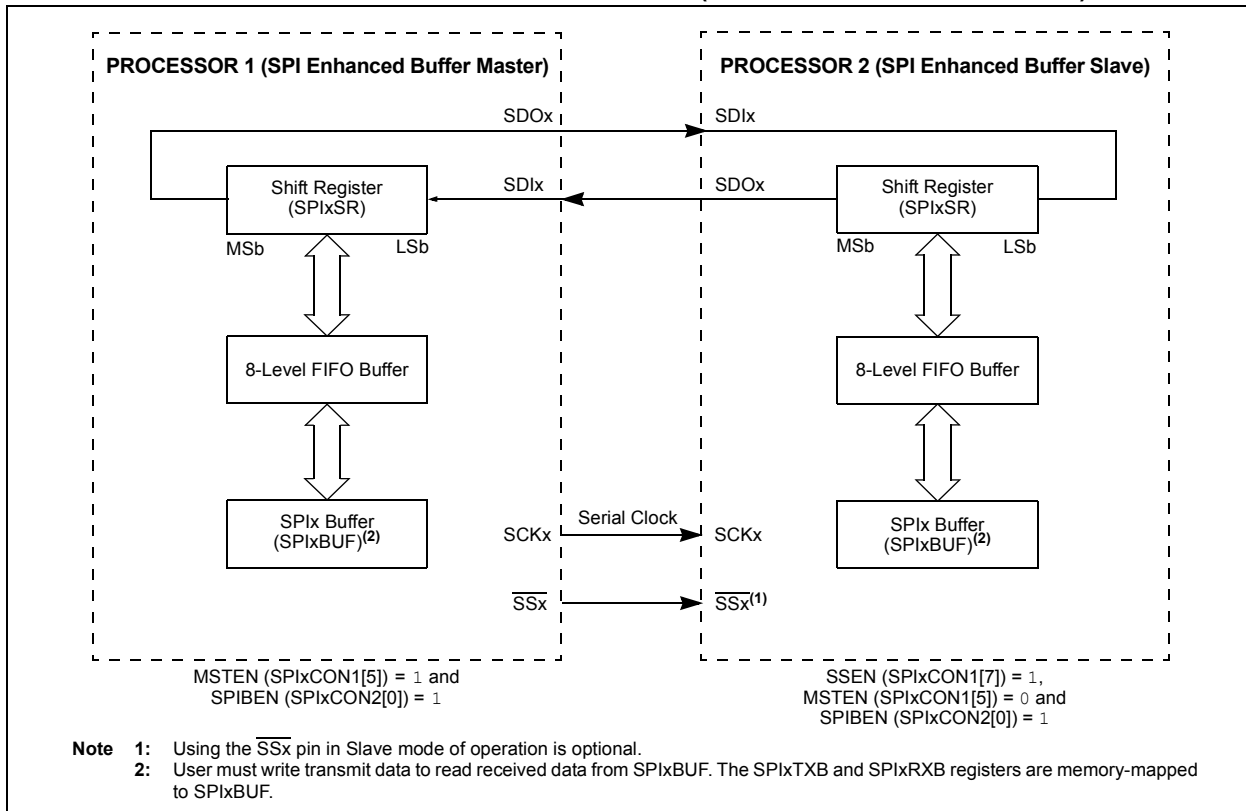
1 = Enhanced Buffer enabled  
 0 = Enhanced Buffer disabled (Legacy mode)

# PIC24FJ256GA110 FAMILY

**FIGURE 15-3: SPI MASTER/SLAVE CONNECTION (STANDARD MODE)**

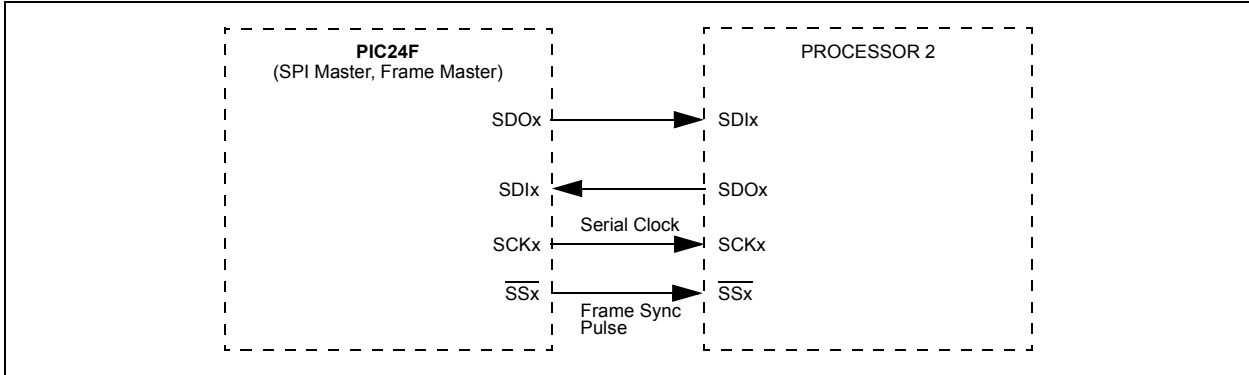


**FIGURE 15-4: SPI MASTER/SLAVE CONNECTION (ENHANCED BUFFER MODES)**

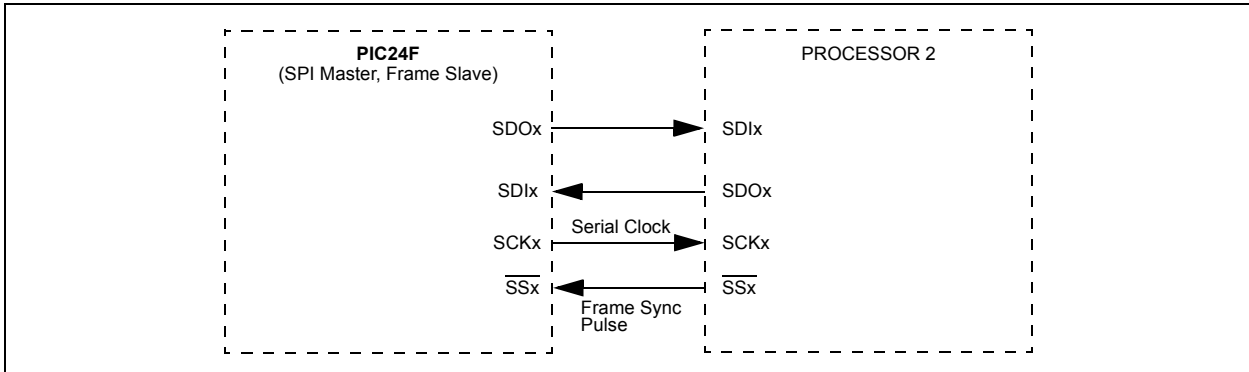


# PIC24FJ256GA110 FAMILY

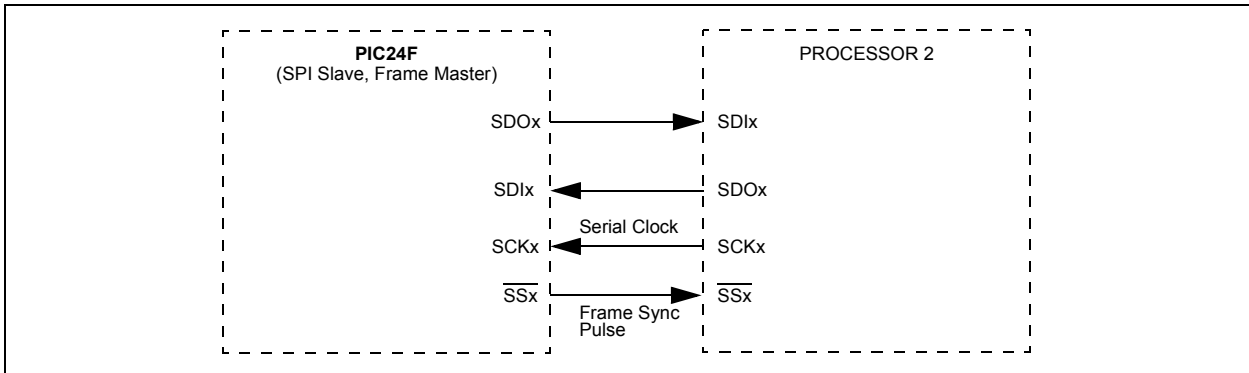
**FIGURE 15-5: SPI MASTER, FRAME MASTER CONNECTION DIAGRAM**



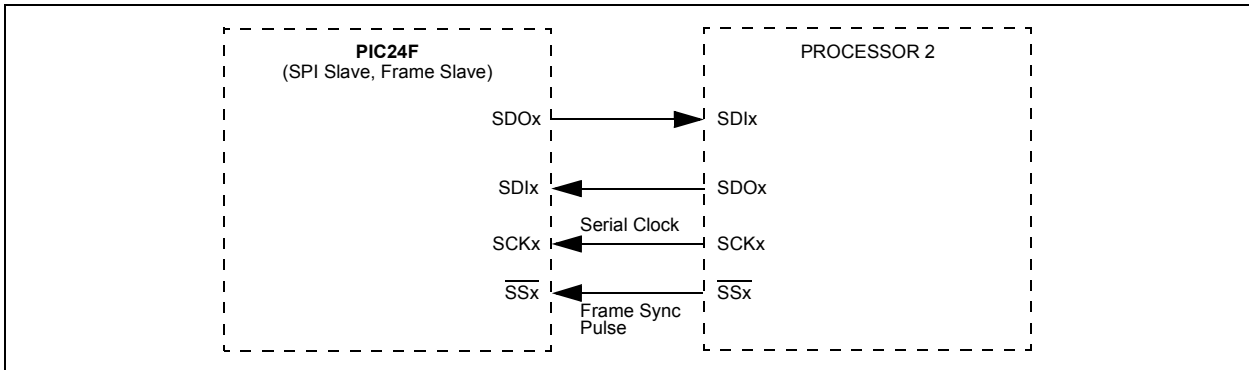
**FIGURE 15-6: SPI MASTER, FRAME SLAVE CONNECTION DIAGRAM**



**FIGURE 15-7: SPI SLAVE, FRAME MASTER CONNECTION DIAGRAM**



**FIGURE 15-8: SPI SLAVE, FRAME SLAVE CONNECTION DIAGRAM**



# PIC24FJ256GA110 FAMILY

**EQUATION 15-1: RELATIONSHIP BETWEEN DEVICE AND SPI CLOCK SPEED<sup>(1)</sup>**

$$F_{SCK} = \frac{F_{CY}}{\text{Primary Prescaler} * \text{Secondary Prescaler}}$$

**Note 1:** Based on  $F_{CY} = F_{OSC}/2$ ; Doze mode and PLL are disabled.

**TABLE 15-1: SAMPLE SCK FREQUENCIES<sup>(1,2)</sup>**

F <sub>cy</sub> = 16 MHz		Secondary Prescaler Settings				
		1:1	2:1	4:1	6:1	8:1
Primary Prescaler Settings	1:1	Invalid	8000	4000	2667	2000
	4:1	4000	2000	1000	667	500
	16:1	1000	500	250	167	125
	64:1	250	125	63	42	31
F <sub>cy</sub> = 5 MHz						
Primary Prescaler Settings	1:1	5000	2500	1250	833	625
	4:1	1250	625	313	208	156
	16:1	313	156	78	52	39
	64:1	78	39	20	13	10

**Note 1:** Based on  $F_{CY} = F_{OSC}/2$ ; Doze mode and PLL are disabled.

**Note 2:** SCKx frequencies shown in kHz.

## 16.0 INTER-INTEGRATED CIRCUIT (I<sup>2</sup>C)

**Note:** This data sheet summarizes the features of this group of PIC24F devices. It is not intended to be a comprehensive reference source. For more information, refer to “**Inter-Integrated Circuit (I<sup>2</sup>C)**” ([www.microchip.com/DS70000195](http://www.microchip.com/DS70000195)) in the “*dsPIC33/PIC24 Family Reference Manual*”. The information in this data sheet supersedes the information in the FRM.

The Inter-Integrated Circuit (I<sup>2</sup>C) module is a serial interface useful for communicating with other peripheral or microcontroller devices. These peripheral devices may be serial EEPROMs, display drivers, A/D Converters, etc.

The I<sup>2</sup>C module supports these features:

- Independent Master and Slave Logic
- 7-Bit and 10-Bit Device Addresses
- General Call Address, as Defined in the I<sup>2</sup>C Protocol
- Clock Stretching to Provide Delays for the Processor to Respond to a Slave Data Request
- Both 100 kHz and 400 kHz Bus Specifications
- Configurable Address Masking
- Multi-Master modes to Prevent Loss of Messages in Arbitration
- Bus Repeater mode, Allowing the Acceptance of All Messages as a Slave Regardless of the Address
- Automatic SCL

A block diagram of the module is shown in [Figure 16-1](#).

### 16.1 Peripheral Remapping Options

The I<sup>2</sup>C modules are tied to fixed pin assignments and cannot be reassigned to alternate pins using Peripheral Pin Select. To allow some flexibility with peripheral multiplexing, the I2C2 module in 100-pin devices can be reassigned to the alternate pins designated as ASCL2 and ASDA2 during device configuration.

Pin assignment is controlled by the I2C2SEL Configuration bit; programming this bit (= 0) multiplexes the module to the ASCL2 and ASDA2 pins.

## 16.2 Communicating as a Master in a Single Master Environment

The details of sending a message in Master mode depends on the communications protocol for the device being communicated with. Typically, the sequence of events is as follows:

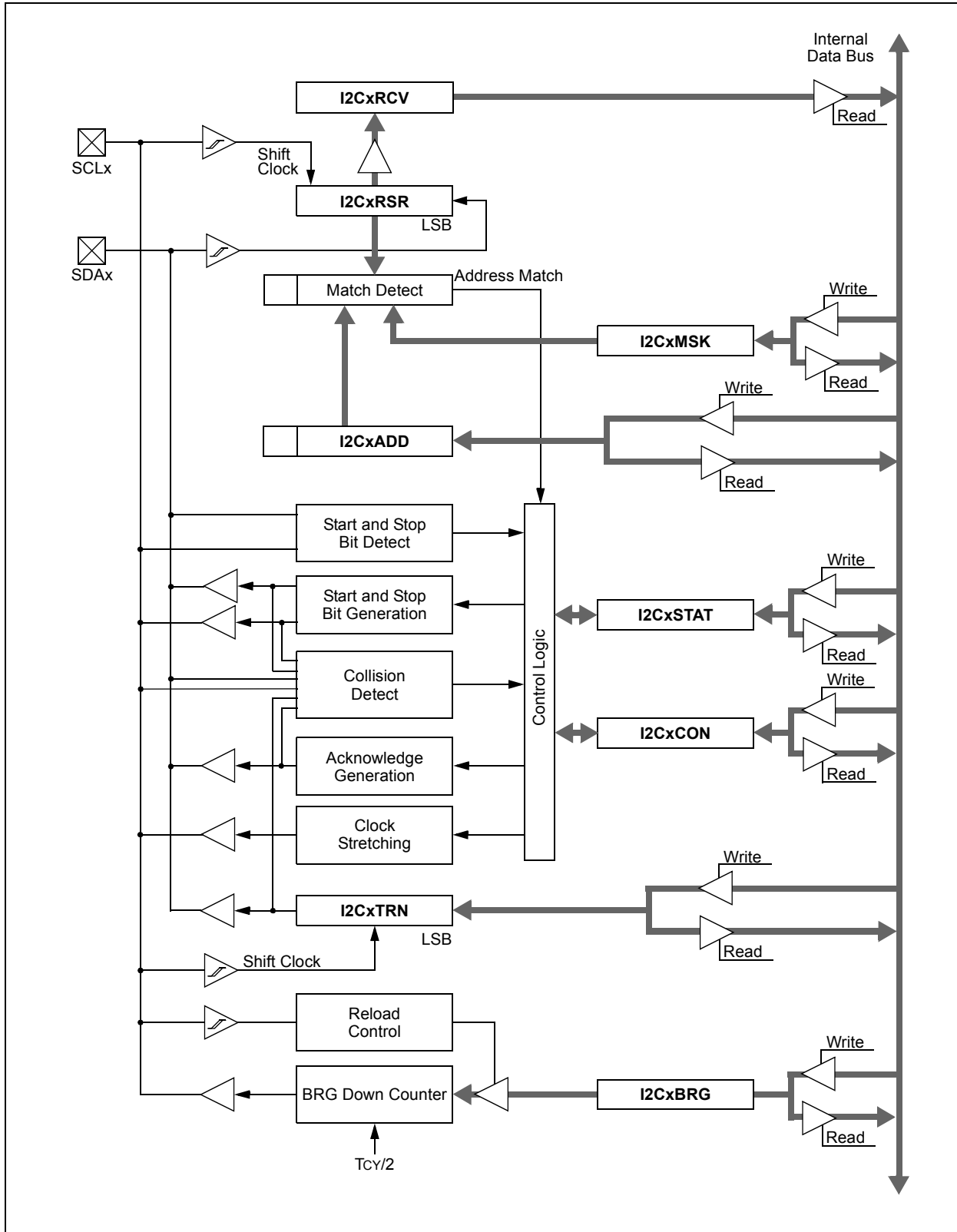
1. Assert a Start condition on SDAx and SCLx.
2. Send the I<sup>2</sup>C device address byte to the slave with a write indication.
3. Wait for and verify an Acknowledge from the slave.
4. Send the first data byte (sometimes known as the command) to the slave.
5. Wait for and verify an Acknowledge from the slave.
6. Send the serial memory address low byte to the slave.
7. Repeat Steps 4 and 5 until all data bytes are sent.
8. Assert a Repeated Start condition on SDAx and SCLx.
9. Send the device address byte to the slave with a read indication.
10. Wait for and verify an Acknowledge from the slave.
11. Enable master reception to receive serial memory data.
12. Generate an ACK or NACK condition at the end of a received byte of data.
13. Generate a Stop condition on SDAx and SCLx.

### 16.3 Clock Stretching

When clock stretching is enabled (STREN = 1) in Slave mode, it will not occur during the address detect phase. As a result, the SCLREL bit will not be cleared upon address reception when the R/W bit is '0'. User software should read the Acknowledged address from the receive buffer before the data byte is received. This can be achieved by configuring the slave interrupt priority so that the interrupt latency is less time than to receive the next byte.

# PIC24FJ256GA110 FAMILY

FIGURE 16-1: I<sup>2</sup>C BLOCK DIAGRAM



# PIC24FJ256GA110 FAMILY

## 16.4 Setting Baud Rate When Operating as a Bus Master

To compute the Baud Rate Generator reload value, use Equation 16-1.

**EQUATION 16-1: COMPUTING BAUD RATE RELOAD VALUE<sup>(1,2)</sup>**

$$F_{SCL} = \frac{F_{CY}}{I2CxBRG + 1 + \frac{F_{CY}}{10,000,000}}$$

or

$$I2CxBRG = \left( \frac{F_{CY}}{F_{SCL}} - \frac{F_{CY}}{10,000,000} \right) - 1$$

**Note 1:** Based on  $F_{CY} = F_{OSC}/2$ ; Doze mode and PLL are disabled.

**2:** These clock rate values are for guidance only. The actual clock rate can be affected by various system-level parameters. The actual clock rate should be measured in its intended application.

## 16.5 Slave Address Masking

The I2CxMSK register (Register 16-3) designates address bit positions as “don’t care” for both 7-Bit and 10-Bit Addressing modes. Setting a particular bit location (= 1) in the I2CxMSK register causes the slave module to respond whether the corresponding address bit value is a ‘0’ or a ‘1’. For example, when I2CxMSK is set to ‘00010000’, the slave module will detect both addresses: ‘00000000’ and ‘00100000’.

To enable address masking, the IPMI (Intelligent Peripheral Management Interface) must be disabled by clearing the IPMIEN bit (I2CxCON[11]).

**Note:** As a result of changes in the I<sup>2</sup>C protocol, the addresses in Table 16-2 are reserved and will not be Acknowledged in Slave mode. This includes any address mask settings that include any of these addresses.

**TABLE 16-1: I<sup>2</sup>C CLOCK RATES<sup>(1,2)</sup>**

Required System F <sub>SCL</sub>	F <sub>CY</sub>	I2CxBRG Value		Actual F <sub>SCL</sub>
		(Decimal)	(Hexadecimal)	
100 kHz	16 MHz	157	9D	100 kHz
100 kHz	8 MHz	78	4E	100 kHz
100 kHz	4 MHz	39	27	99 kHz
400 kHz	16 MHz	37	25	404 kHz
400 kHz	8 MHz	18	12	404 kHz
400 kHz	4 MHz	9	9	385 kHz
400 kHz	2 MHz	4	4	385 kHz
1 MHz	16 MHz	13	D	1.026 MHz
1 MHz	8 MHz	6	6	1.026 MHz
1 MHz	4 MHz	3	3	0.909 MHz

**Note 1:** Based on  $F_{CY} = F_{OSC}/2$ ; Doze mode and PLL are disabled.

**2:** These clock rate values are for guidance only. The actual clock rate can be affected by various system-level parameters. The actual clock rate should be measured in its intended application.

**TABLE 16-2: I<sup>2</sup>C RESERVED ADDRESSES<sup>(1)</sup>**

Slave Address	R/W Bit	Description
0000 000	0	General Call Address <sup>(2)</sup>
0000 000	1	Start Byte
0000 001	x	Cbus Address
0000 010	x	Reserved
0000 011	x	Reserved
0000 1xx	x	HS Mode Master Code
1111 1xx	x	Reserved
1111 0xx	x	10-Bit Slave Upper Byte <sup>(3)</sup>

**Note 1:** The address bits listed here will never cause an address match, independent of address mask settings.

**2:** The address will be Acknowledged only if GCEN = 1.

**3:** Match on this address can only occur on the upper byte in 10-Bit Addressing mode.

# PIC24FJ256GA110 FAMILY

## REGISTER 16-1: I2CxCON: I2Cx CONTROL REGISTER

R/W-0	U-0	R/W-0	HC/R/W-1	R/W-0	R/W-0	R/W-0	R/W-0
I2CEN	—	I2CSIDL	SCLREL	IPMIEN	A10M	DISSLW	SMEN
bit 15							bit 8

R/W-0	R/W-0	R/W-0	HC/R/W-0	HC/R/W-0	HC/R/W-0	HC/R/W-0	HC/R/W-0
GCEN	STREN	ACKDT	ACKEN	RCEN	PEN	RSEN	SEN
bit 7							bit 0

<b>Legend:</b>	HC = Hardware Clearable bit		
R = Readable bit	W = Writable bit	U = Unimplemented bit, read as '0'	
-n = Value at POR	'1' = Bit is set	'0' = Bit is cleared	x = Bit is unknown

- bit 15      **I2CEN:** I2Cx Enable bit  
 1 = Enables the I2Cx module and configures the SDAx and SCLx pins as serial port pins  
 0 = Disables I2Cx module; all I<sup>2</sup>C pins are controlled by port functions
- bit 14      **Unimplemented:** Read as '0'
- bit 13      **I2CSIDL:** Stop in Idle Mode bit  
 1 = Discontinues module operation when device enters an Idle mode  
 0 = Continues module operation in Idle mode
- bit 12      **SCLREL:** SCLx Release Control bit (when operating as I<sup>2</sup>C Slave)  
 1 = Releases SCLx clock  
 0 = Holds SCLx clock low (clock stretch)  
If STREN = 1:  
 Bit is R/W (i.e., software may write '0' to initiate stretch and write '1' to release clock); hardware clear at beginning of slave transmission, hardware clear at end of slave reception  
If STREN = 0:  
 Bit is R/S (i.e., software may only write '1' to release clock); hardware clear at beginning of slave transmission
- bit 11      **IPMIEN:** Intelligent Peripheral Management Interface (IPMI) Enable bit  
 1 = IPMI Support mode is enabled; all addresses Acknowledged  
 0 = IPMI mode disabled
- bit 10      **A10M:** 10-Bit Slave Addressing bit  
 1 = I2CxADD is a 10-bit slave address  
 0 = I2CxADD is a 7-bit slave address
- bit 9        **DISSLW:** Disable Slew Rate Control bit  
 1 = Slew rate control disabled  
 0 = Slew rate control enabled
- bit 8        **SMEN:** SMBus Input Levels bit  
 1 = Enables I/O pin thresholds compliant with SMBus specification  
 0 = Disables SMBus input thresholds
- bit 7        **GCEN:** General Call Enable bit (when operating as I<sup>2</sup>C slave)  
 1 = Enables interrupt when a general call address is received in the I2CxRSR (module is enabled for reception)  
 0 = General call address disabled
- bit 6        **STREN:** SCLx Clock Stretch Enable bit (when operating as I<sup>2</sup>C slave)  
 Used in conjunction with the SCLREL bit.  
 1 = Enables software or receive clock stretching  
 0 = Disables software or receive clock stretching

# PIC24FJ256GA110 FAMILY

---

## REGISTER 16-1: I2CxCON: I2Cx CONTROL REGISTER (CONTINUED)

- bit 5      **ACKDT:** Acknowledge Data bit (When operating as I<sup>2</sup>C master. Applicable during master receive.)  
Value that will be transmitted when the software initiates an Acknowledge sequence.  
1 = Sends NACK during Acknowledge  
0 = Sends ACK during Acknowledge
- bit 4      **ACKEN:** Acknowledge Sequence Enable bit (When operating as I<sup>2</sup>C master. Applicable during master receive.)  
1 = Initiates Acknowledge sequence on SDAx and SCLx pins and transmits ACKDT data bit; hardware clear at end of master Acknowledge sequence  
0 = Acknowledge sequence not in progress
- bit 3      **RCEN:** Receive Enable bit (when operating as I<sup>2</sup>C master)  
1 = Enables Receive mode for I<sup>2</sup>C; hardware clear at end of eighth bit of master receive data byte  
0 = Receive sequence not in progress
- bit 2      **PEN:** Stop Condition Enable bit (when operating as I<sup>2</sup>C master)  
1 = Initiates Stop condition on SDAx and SCLx pins; hardware clear at end of master Stop sequence  
0 = Stop condition not in progress
- bit 1      **RSEN:** Repeated Start Condition Enabled bit (when operating as I<sup>2</sup>C master)  
1 = Initiates Repeated Start condition on SDAx and SCLx pins; hardware clear at end of master Repeated Start sequence  
0 = Repeated Start condition not in progress
- bit 0      **SEN:** Start Condition Enabled bit (when operating as I<sup>2</sup>C master)  
1 = Initiates Start condition on SDAx and SCLx pins; hardware clear at end of master Start sequence  
0 = Start condition not in progress

# PIC24FJ256GA110 FAMILY

## REGISTER 16-2: I2CxSTAT: I2Cx STATUS REGISTER

HSC/R-0	HSC/R-0	U-0	U-0	U-0	HS/R/C-0	HSC/R-0	HSC/R-0
ACKSTAT	TRSTAT	—	—	—	BCL	GCSTAT	ADD10
bit 15							bit 8

HS/R/C-0	HS/R/C-0	HSC/R-0	HSC/R/C-0	HSC/R/C-0	HSC/R-0	HSC/R-0	HSC/R-0
IWCOL	I2COV	D $\bar{A}$	P	S	R $\bar{W}$	RBF	TBF
bit 7							bit 0

<b>Legend:</b>	C = Clearable bit	HS = Hardware Settable bit	HSC = Hardware Settable/Clearable bit
R = Readable bit	W = Writable bit	U = Unimplemented bit, read as '0'	
-n = Value at POR	'1' = Bit is set	'0' = Bit is cleared	x = Bit is unknown

- bit 15     **ACKSTAT:** Acknowledge Status bit  
1 = NACK was detected last  
0 = ACK was detected last  
Hardware set or clear at end of Acknowledge.
- bit 14     **TRSTAT:** Transmit Status bit  
(When operating as I<sup>2</sup>C master. Applicable to master transmit operation.)  
1 = Master transmit is in progress (8 bits + ACK)  
0 = Master transmit is not in progress  
Hardware set at beginning of master transmission. Hardware clear at end of slave Acknowledge.
- bit 13-11   **Unimplemented:** Read as '0'
- bit 10     **BCL:** Master Bus Collision Detect bit  
1 = A bus collision has been detected during a master operation  
0 = No collision  
Hardware set at detection of bus collision.
- bit 9     **GCSTAT:** General Call Status bit  
1 = General call address was received  
0 = General call address was not received  
Hardware set when address matches general call address. Hardware clear at Stop detection.
- bit 8     **ADD10:** 10-Bit Address Status bit  
1 = 10-bit address was matched  
0 = 10-bit address was not matched  
Hardware set at match of 2nd byte of matched 10-bit address. Hardware clear at Stop detection.
- bit 7     **IWCOL:** Write Collision Detect bit  
1 = An attempt to write to the I2CxTRN register failed because the I<sup>2</sup>C module is busy  
0 = No collision  
Hardware set at occurrence of write to I2CxTRN while busy (cleared by software).
- bit 6     **I2COV:** Receive Overflow Flag bit  
1 = A byte was received while the I2CxRCV register is still holding the previous byte  
0 = No overflow  
Hardware set at attempt to transfer I2CxRSR to I2CxRCV (cleared by software).
- bit 5     **D $\bar{A}$ :** Data/Address bit (when operating as I<sup>2</sup>C slave)  
1 = Indicates that the last byte received were data  
0 = Indicates that the last byte received was A device address  
Hardware clear at device address match. Hardware set after a transmission finishes or by reception of the slave byte.

# PIC24FJ256GA110 FAMILY

---

## REGISTER 16-2: I2CxSTAT: I2Cx STATUS REGISTER (CONTINUED)

- bit 4     **P:** Stop bit  
1 = Indicates that a Stop bit has been detected last  
0 = Stop bit was not detected last  
Hardware set or clear when Start, Repeated Start or Stop detected.
- bit 3     **S:** Start bit  
1 = Indicates that a Start (or Repeated Start) bit has been detected last  
0 = Start bit was not detected last  
Hardware set or clear when Start, Repeated Start or Stop detected.
- bit 2     **R/W:** Read/Write Information bit (when operating as I<sup>2</sup>C slave)  
1 = Read – indicates data transfer is output from slave  
0 = Write – indicates data transfer is input to slave  
Hardware set or clear after reception of I<sup>2</sup>C device address byte.
- bit 1     **RBF:** Receive Buffer Full Status bit  
1 = Receive complete, I2CxRCV is full  
0 = Receive not complete, I2CxRCV is empty  
Hardware set when I2CxRCV is written with received byte. Hardware clear when software reads I2CxRCV.
- bit 0     **TBF:** Transmit Buffer Full Status bit  
1 = Transmit in progress, I2CxTRN is full  
0 = Transmit complete, I2CxTRN is empty  
Hardware set when software writes I2CxTRN. Hardware clear at completion of data transmission.

# PIC24FJ256GA110 FAMILY

## REGISTER 16-3: I2CxMSK: I2Cx SLAVE MODE ADDRESS MASK REGISTER

U-0	U-0	U-0	U-0	U-0	U-0	R/W-0	R/W-0
—	—	—	—	—	—	AMSK[9:8]	
bit 15							bit 8

R/W-0	R/W-0	R/W-0	R/W-0	R/W-0	R/W-0	R/W-0	R/W-0
AMSK[7:0]							
bit 7							bit 0

### Legend:

R = Readable bit	W = Writable bit	U = Unimplemented bit, read as '0'
-n = Value at POR	'1' = Bit is set	'0' = Bit is cleared
		x = Bit is unknown

bit 15-10     **Unimplemented:** Read as '0'

bit 9-0       **AMSK[9:0]:** Mask for Address Bit x Select bits

1 = Enables masking for bit x of incoming message address; bit match not required in this position

0 = Disables masking for bit x; bit match required in this position

# PIC24FJ256GA110 FAMILY

## 17.0 UNIVERSAL ASYNCHRONOUS RECEIVER TRANSMITTER (UART)

**Note:** This data sheet summarizes the features of this group of PIC24F devices. It is not intended to be a comprehensive reference source. For more information, refer to “Universal Asynchronous Receiver Transmitter (UART)” ([www.microchip.com/DS70000582](http://www.microchip.com/DS70000582)) in the “dsPIC33/PIC24 Family Reference Manual”. The information in this data sheet supersedes the information in the FRM.

The Universal Asynchronous Receiver Transmitter (UART) module is one of the serial I/O modules available in the PIC24F device family. The UART is a full-duplex asynchronous system that can communicate with peripheral devices, such as personal computers, LIN/J2602, RS-232 and RS-485 interfaces. The module also supports a hardware flow control option with the  $\overline{UxCTS}$  and  $\overline{UxRTS}$  pins, and also includes an IrDA® encoder and decoder.

The primary features of the UART module are:

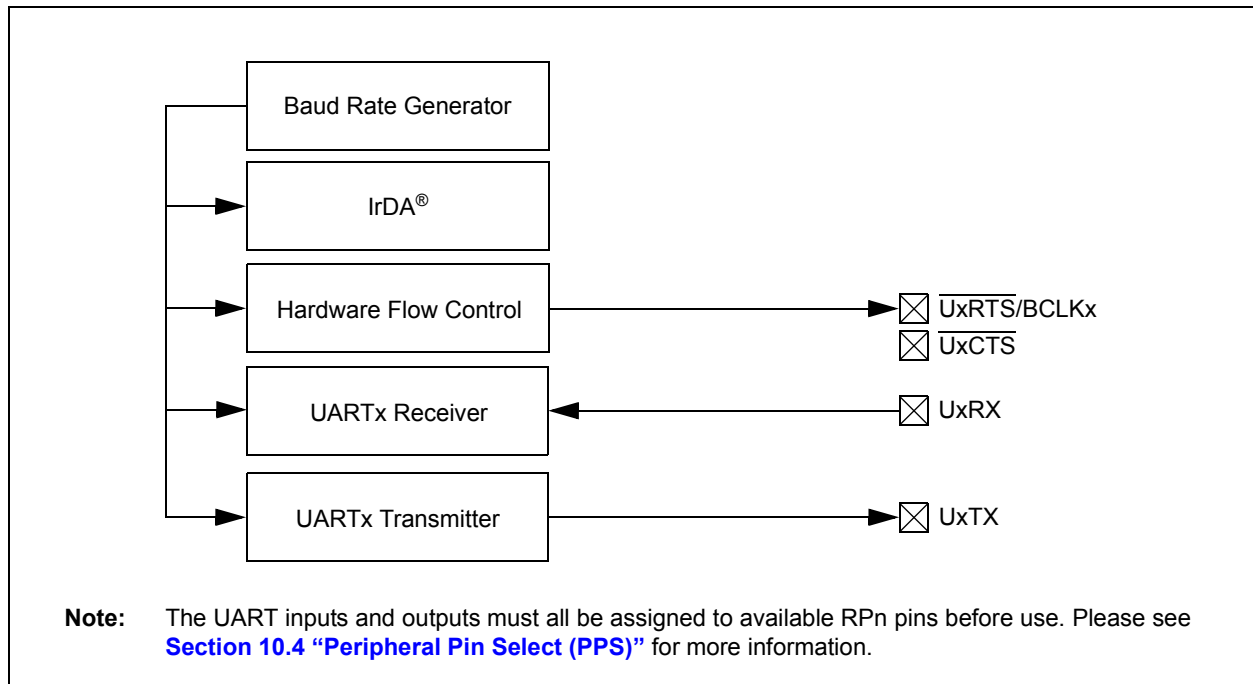
- Full-Duplex, 8 or 9-Bit Data Transmission through the  $UxTX$  and  $UxRX$  Pins
- Even, Odd or No Parity Options (for 8-bit data)
- One or Two Stop Bits

- Hardware Flow Control Option with  $\overline{UxCTS}$  and  $\overline{UxRTS}$  Pins
- Fully Integrated Baud Rate Generator with 16-Bit Prescaler
- Baud Rates Ranging from 1 Mbps to 15 bps at 16 MIPS
- 4-Deep, First-In First-Out (FIFO) Transmit Data Buffer
- 4-Deep FIFO Receive Data Buffer
- Parity, Framing and Buffer Overrun Error Detection
- Support for 9-Bit mode with Address Detect (9th bit = 1)
- Transmit and Receive Interrupts
- Loopback mode for Diagnostic Support
- Support for Sync and Break Characters
- Supports Automatic Baud Rate Detection
- IrDA Encoder and Decoder Logic
- 16x Baud Clock Output for IrDA Support

A simplified block diagram of the UART is shown in Figure 17-1. The UART module consists of these key important hardware elements:

- Baud Rate Generator
- Asynchronous Transmitter
- Asynchronous Receiver

**FIGURE 17-1: UART SIMPLIFIED BLOCK DIAGRAM**



# PIC24FJ256GA110 FAMILY

## 17.1 UART Baud Rate Generator (BRG)

The UART module includes a dedicated 16-bit Baud Rate Generator. The UxBRG register controls the period of a free-running, 16-bit timer. Equation 17-1 shows the formula for computation of the baud rate with BRGH = 0.

### EQUATION 17-1: UART BAUD RATE WITH BRGH = 0<sup>(1,2)</sup>

$$\text{Baud Rate} = \frac{\text{FCY}}{16 \cdot (\text{UxBRG} + 1)}$$

$$\text{UxBRG} = \frac{\text{FCY}}{16 \cdot \text{Baud Rate}} - 1$$

- Note 1:** FCY denotes the instruction cycle clock frequency (FOSC/2).
- 2:** Based on FCY = FOSC/2; Doze mode and PLL are disabled.

Example 17-1 shows the calculation of the baud rate error for the following conditions:

- FCY = 4 MHz
- Desired Baud Rate = 9600

### EXAMPLE 17-1: BAUD RATE ERROR CALCULATION (BRGH = 0)<sup>(1)</sup>

$$\text{Desired Baud Rate} = \text{FCY}/(16 (\text{UxBRG} + 1))$$

Solving for UxBRG value:

$$\text{UxBRG} = ((\text{FCY}/\text{Desired Baud Rate})/16) - 1$$

$$\text{UxBRG} = ((4000000/9600)/16) - 1$$

$$\text{UxBRG} = 25$$

$$\begin{aligned} \text{Calculated Baud Rate} &= 4000000/(16 (25 + 1)) \\ &= 9615 \end{aligned}$$

$$\begin{aligned} \text{Error} &= (\text{Calculated Baud Rate} - \text{Desired Baud Rate}) / \text{Desired Baud Rate} \\ &= (9615 - 9600)/9600 \\ &= 0.16\% \end{aligned}$$

- Note 1:** Based on FCY = FOSC/2; Doze mode and PLL are disabled.

The maximum baud rate (BRGH = 0) possible is FCY/16 (for UxBRG = 0) and the minimum baud rate possible is FCY/(16 \* 65536).

Equation 17-2 shows the formula for computation of the baud rate with BRGH = 1.

### EQUATION 17-2: UART BAUD RATE WITH BRGH = 1<sup>(1,2)</sup>

$$\text{Baud Rate} = \frac{\text{FCY}}{4 \cdot (\text{UxBRG} + 1)}$$

$$\text{UxBRG} = \frac{\text{FCY}}{4 \cdot \text{Baud Rate}} - 1$$

- Note 1:** FCY denotes the instruction cycle clock frequency.
- 2:** Based on FCY = FOSC/2; Doze mode and PLL are disabled.

The maximum baud rate (BRGH = 1) possible is FCY/4 (for UxBRG = 0) and the minimum baud rate possible is FCY/(4 \* 65536).

Writing a new value to the UxBRG register causes the BRG timer to be reset (cleared). This ensures the BRG does not wait for a timer overflow before generating the new baud rate.

## 17.2 Transmitting in 8-Bit Data Mode

1. Set up the UART:
  - a) Write appropriate values for data, parity and Stop bits.
  - b) Write appropriate baud rate value to the UxBRG register.
  - c) Set up transmit and receive interrupt enable and priority bits.
2. Enable the UART.
3. Set the UTXEN bit (causes a transmit interrupt two cycles after being set).
4. Write data byte to lower byte of UxTXREG word. The value will be immediately transferred to the Transmit Shift Register (TSR) and the serial bit stream will start shifting out with the next rising edge of the baud clock.
5. Alternately, the data byte may be transferred while UTXEN = 0, and then the user may set UTXEN. This will cause the serial bit stream to begin immediately because the baud clock will start from a cleared state.
6. A transmit interrupt will be generated as per interrupt control bit, UTXISELx.

## 17.3 Transmitting in 9-Bit Data Mode

1. Set up the UART (as described in [Section 17.2 “Transmitting in 8-Bit Data Mode”](#)).
2. Enable the UART.
3. Set the UTXEN bit (causes a transmit interrupt).
4. Write UxTXREG as a 16-bit value only.
5. A word write to UxTXREG triggers the transfer of the 9-bit data to the TSR. The serial bit stream will start shifting out with the first rising edge of the baud clock.
6. A transmit interrupt will be generated as per the setting of control bit, UTXISELx.

## 17.4 Break and Sync Transmit Sequence

The following sequence will send a message frame header made up of a Break, followed by an Auto-Baud Sync byte.

1. Configure the UART for the desired mode.
2. Set UTXEN and UTXBRK to set up the Break character.
3. Load the UxTXREG with a dummy character to initiate transmission (value is ignored).
4. Write '55h' to UxTXREG; this loads the Sync character into the transmit FIFO.
5. After the Break has been sent, the UTXBRK bit is reset by hardware. The Sync character now transmits.

## 17.5 Receiving in 8-Bit or 9-Bit Data Mode

1. Set up the UART (as described in [Section 17.2 “Transmitting in 8-Bit Data Mode”](#)).
2. Enable the UART.
3. A receive interrupt will be generated when one or more data characters have been received as per interrupt control bit, URXISELx.
4. Read the OERR bit to determine if an overrun error has occurred. The OERR bit must be reset in software.
5. Read UxRXREG.

The act of reading the UxRXREG character will move the next character to the top of the receive FIFO, including a new set of PERR and FERR values.

## 17.6 Operation of $\overline{\text{UxCTS}}$ and $\overline{\text{UxRTS}}$ Control Pins

UARTx Clear-to-Send ( $\overline{\text{UxCTS}}$ ) and Request-to-Send ( $\overline{\text{UxRTS}}$ ) are the two hardware-controlled pins that are associated with the UART module. These two pins allow the UART to operate in Simplex and Flow Control mode. They are implemented to control the transmission and reception between the Data Terminal Equipment (DTE). The UEN[1:0] bits in the UxMODE register configure these pins.

## 17.7 Infrared Support

The UART module provides two types of infrared UART support: one is the IrDA clock output to support external IrDA encoder and decoder device (legacy module support), and the other is the full implementation of the IrDA encoder and decoder. Note that because the IrDA modes require a 16x baud clock, they will only work when the BRGH bit (UxMODE[3]) is '0'.

### 17.7.1 IrDA CLOCK OUTPUT FOR EXTERNAL IrDA SUPPORT

To support external IrDA encoder and decoder devices, the BCLKx pin (same as the UxRTS pin) can be configured to generate the 16x baud clock. When UEN[1:0] = 11, the BCLKx pin will output the 16x baud clock if the UART module is enabled. It can be used to support the IrDA codec chip.

### 17.7.2 BUILT-IN IrDA ENCODER AND DECODER

The UART has full implementation of the IrDA encoder and decoder as part of the UART module. The built-in IrDA encoder and decoder functionality is enabled using the IREN bit (UxMODE[12]). When enabled (IREN = 1), the receive pin (UxRX) acts as the input from the infrared receiver. The transmit pin (UxTX) acts as the output to the infrared transmitter.

# PIC24FJ256GA110 FAMILY

## REGISTER 17-1: UxMODE: UARTx MODE REGISTER

R/W-0	U-0	R/W-0	R/W-0	R/W-0	U-0	R/W-0	R/W-0
UARTEN <sup>(1)</sup>	—	USIDL	IREN <sup>(2)</sup>	RTSMD	—	UEN1	UEN0
bit 15						bit 8	

HC/R/C-0	R/W-0	HC/R/W-0	R/W-0	R/W-0	R/W-0	R/W-0	R/W-0
WAKE	LPBACK	ABAUD	RXINV	BRGH	PDSEL1	PDSEL0	STSEL
bit 7						bit 0	

<b>Legend:</b>	C = Clearable bit	HC = Hardware Clearable bit
R = Readable bit	W = Writable bit	U = Unimplemented bit, read as '0'
-n = Value at POR	'1' = Bit is set	'0' = Bit is cleared      x = Bit is unknown

- bit 15      **UARTEN:** UARTx Enable bit<sup>(1)</sup>  
 1 = UARTx is enabled; all UARTx pins are controlled by UARTx as defined by UEN[1:0]  
 0 = UARTx is disabled; all UARTx pins are controlled by port latches, UARTx power consumption is minimal
- bit 14      **Unimplemented:** Read as '0'
- bit 13      **USIDL:** Stop in Idle Mode bit  
 1 = Discontinues module operation when the device enters Idle mode  
 0 = Continues module operation in Idle mode
- bit 12      **IREN:** IrDA<sup>®</sup> Encoder and Decoder Enable bit<sup>(2)</sup>  
 1 = IrDA encoder and decoder are enabled  
 0 = IrDA encoder and decoder are disabled
- bit 11      **RTSMD:** Mode Selection for  $\overline{\text{UxRTS}}$  Pin bit  
 1 =  $\overline{\text{UxRTS}}$  pin in Simplex mode  
 0 =  $\overline{\text{UxRTS}}$  pin in Flow Control mode
- bit 10      **Unimplemented:** Read as '0'
- bit 9-8      **UEN[1:0]:** UARTx Enable bits  
 11 = UxTX, UxRX and BCLKx pins are enabled and used;  $\overline{\text{UxCTS}}$  pin is controlled by port latches  
 10 = UxTX, UxRX,  $\overline{\text{UxCTS}}$  and  $\overline{\text{UxRTS}}$  pins are enabled and used  
 01 = UxTX, UxRX and  $\overline{\text{UxRTS}}$  pins are enabled and used;  $\overline{\text{UxCTS}}$  pin is controlled by port latches  
 00 = UxTX and UxRX pins are enabled and used;  $\overline{\text{UxCTS}}$  and  $\overline{\text{UxRTS}}$ /BCLKx pins are controlled by port latches
- bit 7      **WAKE:** Wake-up on Start Bit Detect During Sleep Mode Enable bit  
 1 = UARTx will continue to sample the UxRX pin; interrupt generated on falling edge, bit cleared in hardware on following rising edge  
 0 = No wake-up enabled
- bit 6      **LPBACK:** UARTx Loopback Mode Select bit  
 1 = Enables Loopback mode  
 0 = Loopback mode is disabled
- bit 5      **ABAUD:** Auto-Baud Enable bit  
 1 = Enables baud rate measurement on the next character – requires reception of a Sync field (55h); cleared in hardware upon completion  
 0 = Baud rate measurement is disabled or completed

**Note 1:** If UARTEN = 1, the peripheral inputs and outputs must be configured to an available RPN pin. See [Section 10.4 “Peripheral Pin Select \(PPS\)”](#) for more information.

**2:** This feature is only available for the 16x BRG mode (BRGH = 0).

# PIC24FJ256GA110 FAMILY

---

## REGISTER 17-1: UxMODE: UARTx MODE REGISTER (CONTINUED)

- bit 4        **RXINV:** Receive Polarity Inversion bit  
            1 = UxRX Idle state is '0'  
            0 = UxRX Idle state is '1'
- bit 3        **BRGH:** High Baud Rate Enable bit  
            1 = High-Speed mode (baud clock generated from  $F_{CY}/4$ )  
            0 = Standard mode (baud clock generated from  $F_{CY}/16$ )
- bit 2-1     **PDSEL[1:0]:** Parity and Data Selection bits  
            11 = 9-bit data, no parity  
            10 = 8-bit data, odd parity  
            01 = 8-bit data, even parity  
            00 = 8-bit data, no parity
- bit 0        **STSEL:** Stop Bit Selection bit  
            1 = Two Stop bits  
            0 = One Stop bit

- Note 1:** If `UARTEN = 1`, the peripheral inputs and outputs must be configured to an available RPN pin. See [Section 10.4 "Peripheral Pin Select \(PPS\)"](#) for more information.
- 2:** This feature is only available for the 16x BRG mode (`BRGH = 0`).

# PIC24FJ256GA110 FAMILY

## REGISTER 17-2: UxSTA: UARTx STATUS AND CONTROL REGISTER

R/W-0	R/W-0	R/W-0	U-0	HC/R/W-0	R/W-0	R-0	R-1
UTXISEL1	UTXINV <sup>(1)</sup>	UTXISEL0	—	UTXBRK	UTXEN <sup>(2)</sup>	UTXBF	TRMT
bit 15							bit 8

R/W-0	R/W-0	R/W-0	R-1	R-0	R-0	R/C-0	R-0
URXISEL1	URXISEL0	ADDEN	RIDLE	PERR	FERR	OERR	URXDA
bit 7							bit 0

<b>Legend:</b>	C = Clearable bit	HC = Hardware Clearable bit
R = Readable bit	W = Writable bit	U = Unimplemented bit, read as '0'
-n = Value at POR	'1' = Bit is set	'0' = Bit is cleared      x = Bit is unknown

- bit 15,13      **UTXISEL[1:0]:** Transmission Interrupt Mode Selection bits  
 11 = Reserved; do not use  
 10 = Interrupt when a character is transferred to the Transmit Shift Register (TSR), and as a result, the transmit buffer becomes empty  
 01 = Interrupt when the last character is shifted out of the Transmit Shift Register; all transmit operations are completed  
 00 = Interrupt when a character is transferred to the Transmit Shift Register (this implies there is at least one character open in the transmit buffer)
- bit 14      **UTXINV:** IrDA<sup>®</sup> Encoder Transmit Polarity Inversion bit<sup>(2)</sup>  
IREN = 0:  
 1 = UxTX Idle '0'  
 0 = UxTX Idle '1'  
IREN = 1:  
 1 = UxTX Idle '1'  
 0 = UxTX Idle '0'
- bit 12      **Unimplemented:** Read as '0'
- bit 11      **UTXBRK:** Transmit Break bit  
 1 = Sends Sync Break on next transmission – Start bit, followed by twelve '0' bits, followed by Stop bit; cleared by hardware upon completion  
 0 = Sync Break transmission is disabled or completed
- bit 10      **UTXEN:** Transmit Enable bit<sup>(2)</sup>  
 1 = Transmit enabled; UxTX pin is controlled by UARTx  
 0 = Transmit disabled; any pending transmission is aborted and the buffer is reset, UxTX pin is controlled by port
- bit 9      **UTXBF:** Transmit Buffer Full Status bit (read-only)  
 1 = Transmit buffer is full  
 0 = Transmit buffer is not full; at least one more character can be written
- bit 8      **TRMT:** Transmit Shift Register Empty bit (read-only)  
 1 = Transmit Shift Register is empty and transmit buffer is empty (the last transmission has completed)  
 0 = Transmit Shift Register is not empty, a transmission is in progress or queued
- bit 7-6      **URXISEL[1:0]:** Receive Interrupt Mode Selection bits  
 11 = Interrupt is set on RSR transfer, making the receive buffer full (i.e., has four data characters)  
 10 = Interrupt is set on RSR transfer, making the receive buffer 3/4 full (i.e., has three data characters)  
 0x = Interrupt is set when any character is received and transferred from the RSR to the receive buffer; receive buffer has one or more characters

- Note 1:** Value of bit only affects the transmit properties of the module when the IrDA<sup>®</sup> encoder is enabled (IREN = 1).  
**Note 2:** If UARTEN = 1, the peripheral inputs and outputs must be configured to an available RPN pin. See [Section 10.4 “Peripheral Pin Select \(PPS\)”](#) for more information.

# PIC24FJ256GA110 FAMILY

---

## REGISTER 17-2: UxSTA: UARTx STATUS AND CONTROL REGISTER (CONTINUED)

- bit 5      **ADDEN:** Address Character Detect bit (bit 8 of received data = 1)  
1 = Address Detect mode enabled; if 9-bit mode is not selected, this does not take effect  
0 = Address Detect mode disabled
- bit 4      **RIDLE:** Receiver Idle bit (read-only)  
1 = Receiver is Idle  
0 = Receiver is active
- bit 3      **PERR:** Parity Error Status bit (read-only)  
1 = Parity error has been detected for the current character (character at the top of the receive FIFO)  
0 = Parity error has not been detected
- bit 2      **FERR:** Framing Error Status bit (read-only)  
1 = Framing error has been detected for the current character (character at the top of the receive FIFO)  
0 = Framing error has not been detected
- bit 1      **OERR:** Receive Buffer Overrun Error Status bit (clear/read-only)  
1 = Receive buffer has overflowed  
0 = Receive buffer has not overflowed (clearing a previously set OERR bit (1 → 0 transition) will reset the receiver buffer and the RSR to the empty state)
- bit 0      **URXDA:** Receive Buffer Data Available bit (read-only)  
1 = Receive buffer has data; at least one more character can be read  
0 = Receive buffer is empty

- Note 1:** Value of bit only affects the transmit properties of the module when the IrDA<sup>®</sup> encoder is enabled (IREN = 1).
- Note 2:** If UARTEN = 1, the peripheral inputs and outputs must be configured to an available RPN pin. See [Section 10.4 “Peripheral Pin Select \(PPS\)”](#) for more information.

# PIC24FJ256GA110 FAMILY

---

NOTES:

## 18.0 PARALLEL MASTER PORT (PMP)

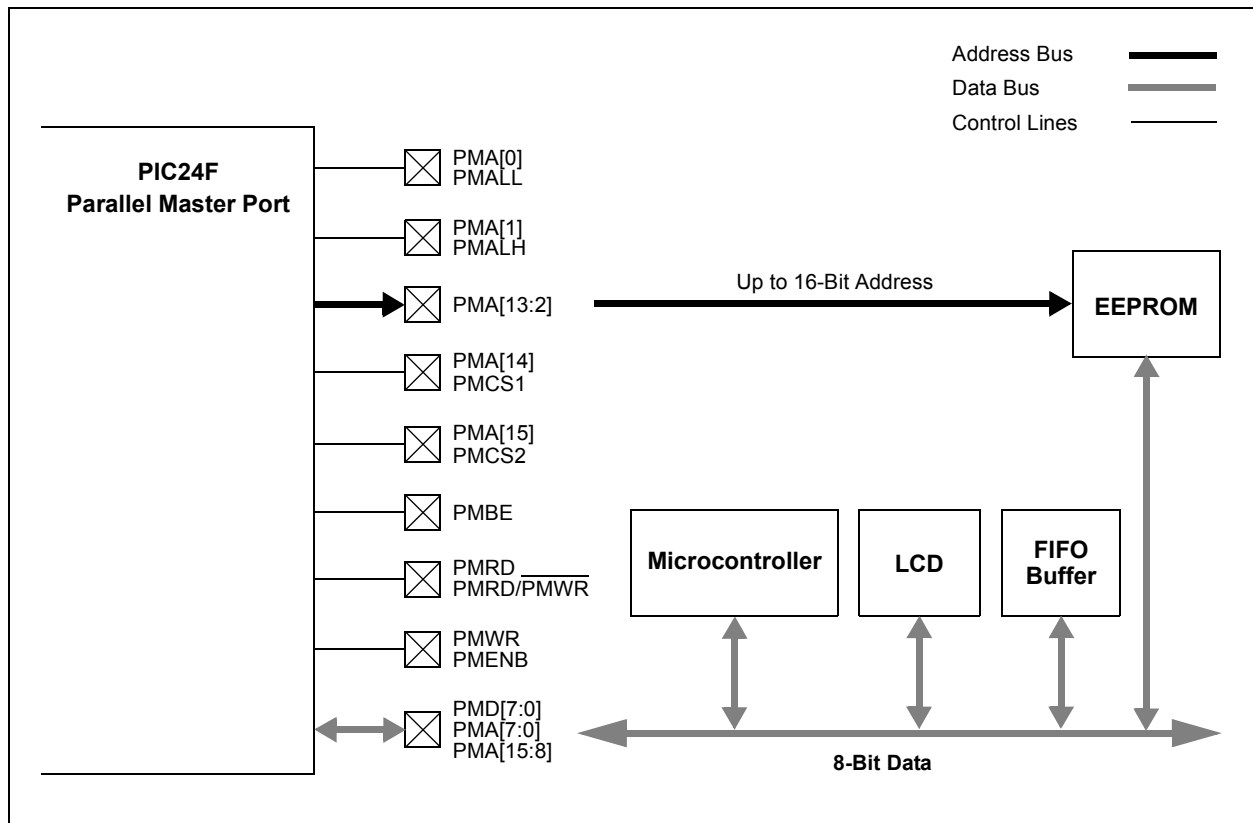
**Note:** This data sheet summarizes the features of this group of PIC24F devices. It is not intended to be a comprehensive reference source. For more information, refer to “Parallel Master Port (PMP)” ([www.microchip.com/DS70005344](http://www.microchip.com/DS70005344)) in the “dsPIC33/PIC24 Family Reference Manual”. The information in this data sheet supersedes the information in the FRM.

The Parallel Master Port (PMP) module is a parallel, 8-bit I/O module, specifically designed to communicate with a wide variety of parallel devices, such as communication peripherals, LCDs, external memory devices and microcontrollers. Because the interface to parallel peripherals varies significantly, the PMP is highly configurable.

Key features of the PMP module include:

- Up to 16 Programmable Address Lines
- Up to Two Chip Select Lines
- Programmable Strobe Options:
  - Individual read and write strobes or;
  - Read/Write strobe with enable strobe
- Address Auto-Increment/Auto-Decrement
- Programmable Address/Data Multiplexing
- Programmable Polarity on Control Signals
- Legacy Parallel Slave Port Support
- Enhanced Parallel Slave Support:
  - Address support
  - 4-byte deep auto-incrementing buffer
- Programmable Wait States
- Selectable Input Voltage Levels

**FIGURE 18-1: PMP MODULE OVERVIEW**



# PIC24FJ256GA110 FAMILY

## REGISTER 18-1: PMCON: PARALLEL MASTER PORT CONTROL REGISTER

R/W-0	U-0	R/W-0	R/W-0	R/W-0	R/W-0	R/W-0	R/W-0
PMPEN	—	PSIDL	ADRMUX1	ADRMUX0	PTBEEN	PTWREN	PTRDEN
bit 15							bit 8

R/W-0	R/W-0	R/W-0 <sup>(1)</sup>	R/W-0 <sup>(1)</sup>	R/W-0 <sup>(1)</sup>	R/W-0	R/W-0	R/W-0
CSF1	CSF0	ALP	CS2P	CS1P	BEP	WRSP	RDSP
bit 7							bit 0

### Legend:

R = Readable bit                      W = Writable bit                      U = Unimplemented bit, read as '0'  
 -n = Value at POR                      '1' = Bit is set                      '0' = Bit is cleared                      x = Bit is unknown

- bit 15        **PMPEN:** Parallel Master Port Enable bit  
                  1 = PMP enabled  
                  0 = PMP disabled, no off-chip access performed
- bit 14        **Unimplemented:** Read as '0'
- bit 13        **PSIDL:** Stop in Idle Mode bit  
                  1 = Discontinues module operation when device enters Idle mode  
                  0 = Continues module operation in Idle mode
- bit 12-11    **ADRMUX[1:0]:** Address/Data Multiplexing Selection bits  
                  11 = Reserved  
                  10 = All 16 bits of address are multiplexed on PMD[7:0] pins  
                  01 = Lower eight bits of address are multiplexed on PMD[7:0] pins; upper three bits are multiplexed on PMA[10:8]  
                  00 = Address and data appear on separate pins
- bit 10        **PTBEEN:** Byte Enable Port Enable bit (16-Bit Master mode)  
                  1 = PMBE port enabled  
                  0 = PMBE port disabled
- bit 9         **PTWREN:** Write Enable Strobe Port Enable bit  
                  1 = PMWR/PMENB port enabled  
                  0 = PMWR/PMENB port disabled
- bit 8         **PTRDEN:** Read/Write Strobe Port Enable bit  
                  1 = PMRD/PMWR port enabled  
                  0 = PMRD/PMWR port disabled
- bit 7-6      **CSF[1:0]:** Chip Select Function bits  
                  11 = Reserved  
                  10 = PMCS1 and PMCS2 function as chip select  
                  01 = PMCS2 functions as chip select, PMCS1 functions as Address Bit 14  
                  00 = PMCS1 and PMCS2 function as Address Bits 15 and 14
- bit 5         **ALP:** Address Latch Polarity bit<sup>(1)</sup>  
                  1 = Active-high (PMALL and PMALH)  
                  0 = Active-low (PMALL and PMALH)
- bit 4         **CS2P:** Chip Select 2 Polarity bit<sup>(1)</sup>  
                  1 = Active-high (PMCS2/PMCS2)  
                  0 = Active-low (PMCS2/PMCS2)

**Note 1:** These bits have no effect when their corresponding pins are used as address lines.

# PIC24FJ256GA110 FAMILY

---

## REGISTER 18-1: PMCON: PARALLEL MASTER PORT CONTROL REGISTER (CONTINUED)

bit 3	<b>CS1P:</b> Chip Select 1 Polarity bit <sup>(1)</sup> 1 = Active-high (PMCS1/PMCS1) 0 = Active-low (PMCS1/PMCS1)
bit 2	<b>BEP:</b> Byte Enable Polarity bit 1 = Byte enable active-high (PMBE) 0 = Byte enable active-low (PMBE)
bit 1	<b>WRSP:</b> Write Strobe Polarity bit <u>For Slave Modes and Master Mode 2 (PMMODE[9:8] = 00, 01, 10):</u> 1 = Write strobe active-high (PMWR) 0 = Write strobe active-low (PMWR) <u>For Master Mode 1 (PMMODE[9:8] = 11):</u> 1 = Enable strobe active-high (PMENB) 0 = Enable strobe active-low (PMENB)
bit 0	<b>RDSP:</b> Read Strobe Polarity bit <u>For Slave Modes and Master Mode 2 (PMMODE[9:8] = 00, 01, 10):</u> 1 = Read strobe active-high (PMRD) 0 = Read strobe active-low (PMRD) <u>For Master Mode 1 (PMMODE[9:8] = 11):</u> 1 = Read/write strobe active-high (PMRD/PMWR) 0 = Read/write strobe active-low (PMRD/PMWR)

**Note 1:** These bits have no effect when their corresponding pins are used as address lines.

# PIC24FJ256GA110 FAMILY

## REGISTER 18-2: PMMODE: PARALLEL MASTER PORT MODE REGISTER

R-0	R/W-0	R/W-0	R/W-0	R/W-0	R/W-0	R/W-0	R/W-0
BUSY	IRQM1	IRQM0	INCM1	INCM0	MODE16	MODE1	MODE0
bit 15							bit 8

R/W-0	R/W-0	R/W-0	R/W-0	R/W-0	R/W-0	R/W-0	R/W-0
WAITB1 <sup>(1)</sup>	WAITB0 <sup>(1)</sup>	WAITM3	WAITM2	WAITM1	WAITM0	WAITE1 <sup>(1)</sup>	WAITE0 <sup>(1)</sup>
bit 7							bit 0

### Legend:

R = Readable bit                      W = Writable bit                      U = Unimplemented bit, read as '0'  
 -n = Value at POR                      '1' = Bit is set                      '0' = Bit is cleared                      x = Bit is unknown

- bit 15            **BUSY:** Busy bit (Master mode only)  
 1 = Port is busy (not useful when the processor Stall is active)  
 0 = Port is not busy
- bit 14-13       **IRQM[1:0]:** Interrupt Request Mode bits  
 11 = Interrupt generated when Read Buffer 3 is read or Write Buffer 3 is written (Buffered PSP mode),  
       or on a read or write operation when PMA[1:0] = 11 (Addressable PSP mode only)  
 10 = No interrupt generated, processor Stall activated  
 01 = Interrupt generated at the end of the read/write cycle  
 00 = No interrupt generated
- bit 12-11       **INCM[1:0]:** Increment Mode bits  
 11 = PSP read and write buffers auto-increment (Legacy PSP mode only)  
 10 = Decrement ADDR[10:0] by one every read/write cycle  
 01 = Increment ADDR[10:0] by one every read/write cycle  
 00 = No increment or decrement of address
- bit 10           **MODE16:** 8/16-Bit Mode bit  
 1 = 16-Bit Mode: Data register is 16 bits; a read or write to the Data register invokes two 8-bit transfers  
 0 = 8-bit mode: Data register is 8 bits; a read or write to the Data register invokes one 8-bit transfer
- bit 9-8          **MODE[1:0]:** Parallel Port Mode Select bits  
 11 = Master Mode 1 (PMCS1, PMRD/PMWR, PMENB, PMBE, PMA[x:0] and PMD[7:0])  
 10 = Master Mode 2 (PMCS1, PMRD, PMWR, PMBE, PMA[x:0] and PMD[7:0])  
 01 = Enhanced PSP, control signals (PMRD, PMWR, PMCS1, PMD[7:0] and PMA[1:0])  
 00 = Legacy Parallel Slave Port, control signals (PMRD, PMWR, PMCS1 and PMD[7:0])
- bit 7-6          **WAITB[1:0]:** Data Setup to Read/Write Wait State Configuration bits<sup>(1)</sup>  
 11 = Data Wait of 4 T<sub>cy</sub>; multiplexed address phase of 4 T<sub>cy</sub>  
 10 = Data Wait of 3 T<sub>cy</sub>; multiplexed address phase of 3 T<sub>cy</sub>  
 01 = Data Wait of 2 T<sub>cy</sub>; multiplexed address phase of 2 T<sub>cy</sub>  
 00 = Data Wait of 1 T<sub>cy</sub>; multiplexed address phase of 1 T<sub>cy</sub>
- bit 5-2          **WAITM[3:0]:** Read to Byte Enable Strobe Wait State Configuration bits  
 1111 = Wait of additional 15 T<sub>cy</sub>  
 ...  
 0001 = Wait of additional 1 T<sub>cy</sub>  
 0000 = No additional Wait cycles (operation forced into one T<sub>cy</sub>)<sup>(2)</sup>
- bit 1-0          **WAITE[1:0]:** Data Hold After Strobe Wait State Configuration bits<sup>(1)</sup>  
 11 = Wait of 4 T<sub>cy</sub>  
 10 = Wait of 3 T<sub>cy</sub>  
 01 = Wait of 2 T<sub>cy</sub>  
 00 = Wait of 1 T<sub>cy</sub>

**Note 1:** WAITBx and WAITE<sub>x</sub> bits are ignored whenever WAITM[3:0] = 0000.

**2:** A single cycle delay is required between consecutive read and/or write operations.

# PIC24FJ256GA110 FAMILY

## REGISTER 18-3: PMADDR: PARALLEL MASTER PORT ADDRESS REGISTER

R/W-0	R/W-0	R/W-0	R/W-0	R/W-0	R/W-0	R/W-0	R/W-0
CS2	CS1	ADDR[13:8]					
bit 15							bit 8

R/W-0	R/W-0	R/W-0	R/W-0	R/W-0	R/W-0	R/W-0	R/W-0
ADDR[7:0]							
bit 7							bit 0

### Legend:

R = Readable bit                      W = Writable bit                      U = Unimplemented bit, read as '0'  
 -n = Value at POR                      '1' = Bit is set                      '0' = Bit is cleared                      x = Bit is unknown

- bit 15            **CS2:** Chip Select 2 bit  
                   1 = Chip Select 2 is active  
                   0 = Chip Select 2 is inactive
- bit 14            **CS1:** Chip Select 1 bit  
                   1 = Chip Select 1 is active  
                   0 = Chip Select 1 is inactive
- bit 13-0        **ADDR[13:0]:** Parallel Port Destination Address bits

## REGISTER 18-4: PMAEN: PARALLEL MASTER PORT ENABLE REGISTER

R/W-0	R/W-0	R/W-0	R/W-0	R/W-0	R/W-0	R/W-0	R/W-0
PTEN[15:14]		PTEN[13:8]					
bit 15							bit 8

R/W-0	R/W-0	R/W-0	R/W-0	R/W-0	R/W-0	R/W-0	R/W-0
PTEN[7:2]					PTEN[1:0]		
bit 7							bit 0

### Legend:

R = Readable bit                      W = Writable bit                      U = Unimplemented bit, read as '0'  
 -n = Value at POR                      '1' = Bit is set                      '0' = Bit is cleared                      x = Bit is unknown

- bit 15-14        **PTEN[15:14]:** PMCSx Strobe Enable bits  
                   1 = PMA15 and PMA14 function as either PMA[15:14] or PMCS2 and PMCS1  
                   0 = PMA15 and PMA14 function as port I/Os
- bit 13-2        **PTEN[13:2]:** PMP Address Port Enable bits  
                   1 = PMA[13:2] function as PMP address lines  
                   0 = PMA[13:2] function as port I/Os
- bit 1-0         **PTEN[1:0]:** PMALH/PMALL Strobe Enable bits  
                   1 = PMA1 and PMA0 function as either PMA[1:0] or PMALH and PMALL  
                   0 = PMA1 and PMA0 pads functions as port I/Os

# PIC24FJ256GA110 FAMILY

## REGISTER 18-5: PMSTAT: PARALLEL MASTER PORT STATUS REGISTER

R-0	R/W-0, HS	U-0	U-0	R-0	R-0	R-0	R-0
IBF	IBOV	—	—	IB3F	IB2F	IB1F	IB0F
bit 15							bit 8

R-1	HS/R/W-0	U-0	U-0	R-1	R-1	R-1	R-1
OBE	OBUF	—	—	OB3E	OB2E	OB1E	OB0E
bit 7							bit 0

<b>Legend:</b>	HS = Hardware Settable bit		
R = Readable bit	W = Writable bit	U = Unimplemented bit, read as '0'	
-n = Value at POR	'1' = Bit is set	'0' = Bit is cleared	x = Bit is unknown

- bit 15      **IBF:** Input Buffer Full Status bit  
 1 = All writable Input Buffer registers are full  
 0 = Some or all of the writable Input Buffer registers are empty
- bit 14      **IBOV:** Input Buffer Overflow Status bit  
 1 = A write attempt to a full Input Byte register occurred (must be cleared in software)  
 0 = No overflow occurred
- bit 13-12    **Unimplemented:** Read as '0'
- bit 11-8     **IB3F:IB0F** Input Buffer x Status Full bits  
 1 = Input buffer contains data that have not been read (reading buffer will clear this bit)  
 0 = Input buffer does not contain any unread data
- bit 7        **OBE:** Output Buffer Empty Status bit  
 1 = All readable Output Buffer registers are empty  
 0 = Some or all of the readable Output Buffer registers are full
- bit 6        **OBUF:** Output Buffer Underflow Status bit  
 1 = A read occurred from an empty Output Byte register (must be cleared in software)  
 0 = No underflow occurred
- bit 5-4      **Unimplemented:** Read as '0'
- bit 3-0      **OB3E:OB0E** Output Buffer x Status Empty bits  
 1 = Output buffer is empty (writing data to the buffer will clear this bit)  
 0 = Output buffer contains data that have not been transmitted

# PIC24FJ256GA110 FAMILY

## REGISTER 18-6: PADCFG1: PAD CONFIGURATION CONTROL REGISTER

U-0	U-0	U-0	U-0	U-0	U-0	U-0	U-0
—	—	—	—	—	—	—	—
bit 15							bit 8

U-0	U-0	U-0	U-0	U-0	U-0	R/W-0	R/W-0
—	—	—	—	—	—	RTSECSEL <sup>(1)</sup>	PMPTTL
bit 7							bit 0

### Legend:

R = Readable bit                      W = Writable bit                      U = Unimplemented bit, read as '0'  
 -n = Value at POR                      '1' = Bit is set                      '0' = Bit is cleared                      x = Bit is unknown

bit 15-2                      **Unimplemented:** Read as '0'

bit 1                      **RTSECSEL:** RTCC Seconds Clock Output Select bit<sup>(1)</sup>

- 1 = RTCC seconds clock is selected for the RTCC pin
- 0 = RTCC alarm pulse is selected for the RTCC pin

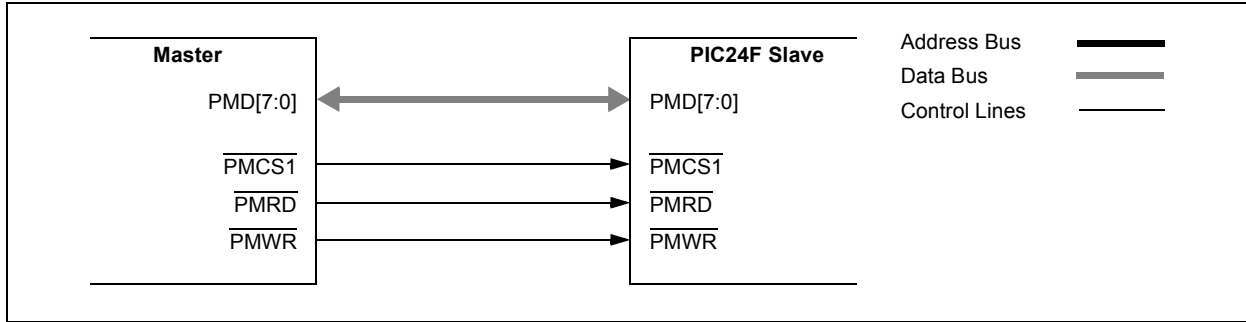
bit 0                      **PMPTTL:** PMP Module TTL Input Buffer Select bit

- 1 = PMP module inputs (PMDx, PMCS1) use TTL input buffers
- 0 = PMP module inputs use Schmitt Trigger input buffers

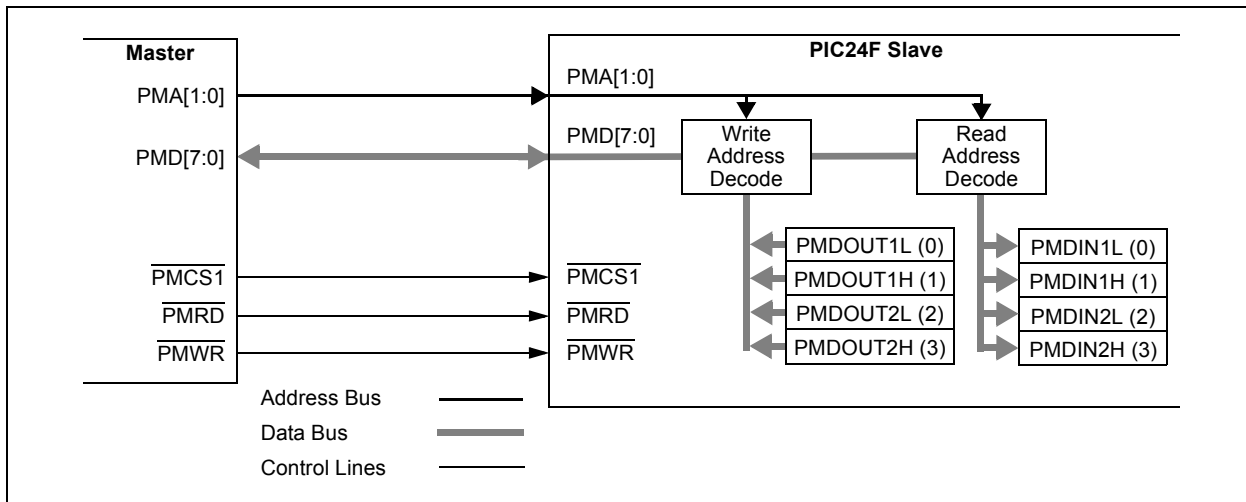
**Note 1:** To enable the actual RTCC output, the RTCOE (RCFGCAL[10]) bit must also be set.

# PIC24FJ256GA110 FAMILY

**FIGURE 18-2: LEGACY PARALLEL SLAVE PORT EXAMPLE**



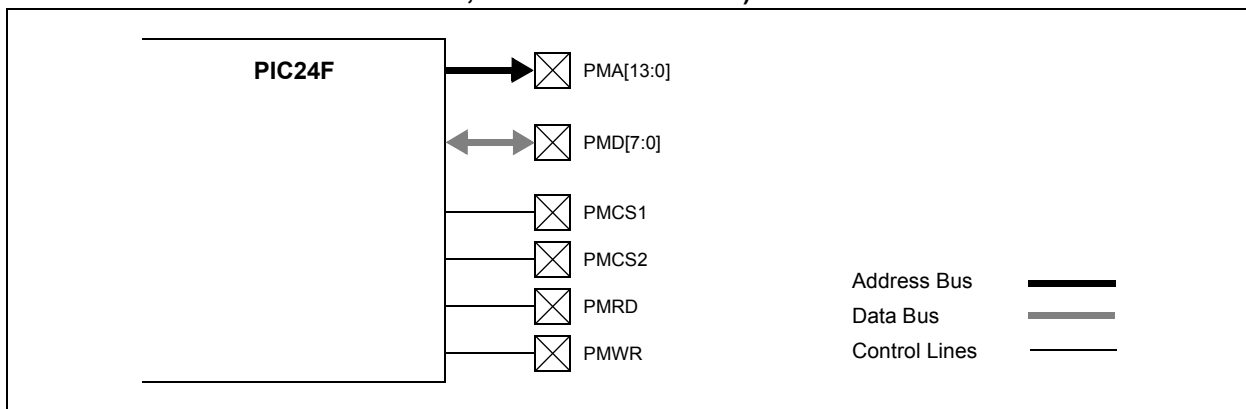
**FIGURE 18-3: ADDRESSABLE PARALLEL SLAVE PORT EXAMPLE**



**TABLE 18-1: SLAVE MODE ADDRESS RESOLUTION**

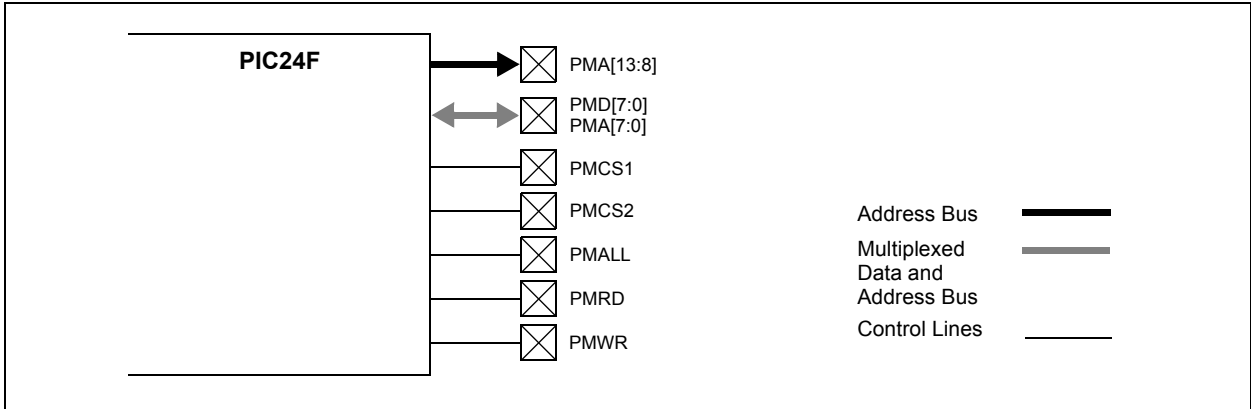
PMA[1:0]	Output Register (Buffer)	Input Register (Buffer)
00	PMDOUT1[7:0] (0)	PMDIN1[7:0] (0)
01	PMDOUT1[15:8] (1)	PMDIN1[15:8] (1)
10	PMDOUT2[7:0] (2)	PMDIN2[7:0] (2)
11	PMDOUT2[15:8] (3)	PMDIN2[15:8] (3)

**FIGURE 18-4: MASTER MODE, DEMULTIPLEXED ADDRESSING (SEPARATE READ AND WRITE STROBES, TWO CHIP SELECTS)**

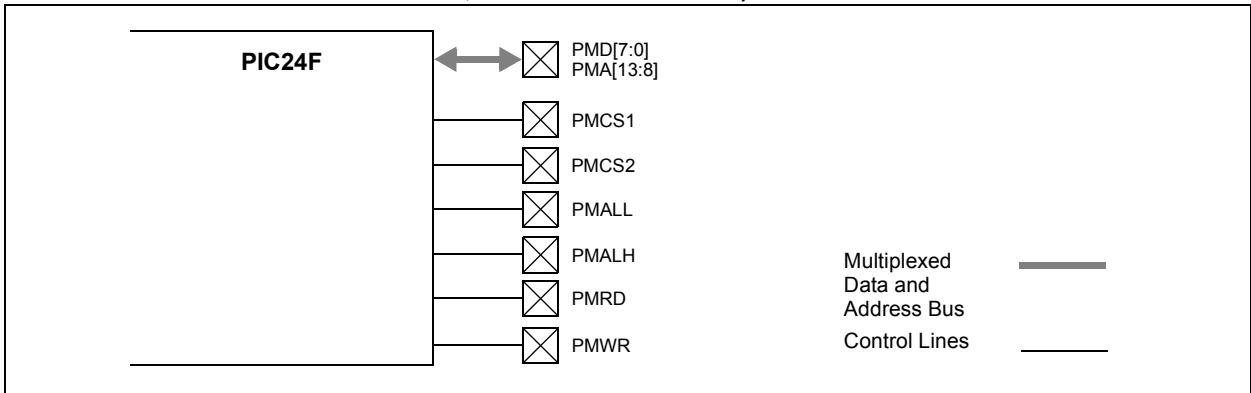


# PIC24FJ256GA110 FAMILY

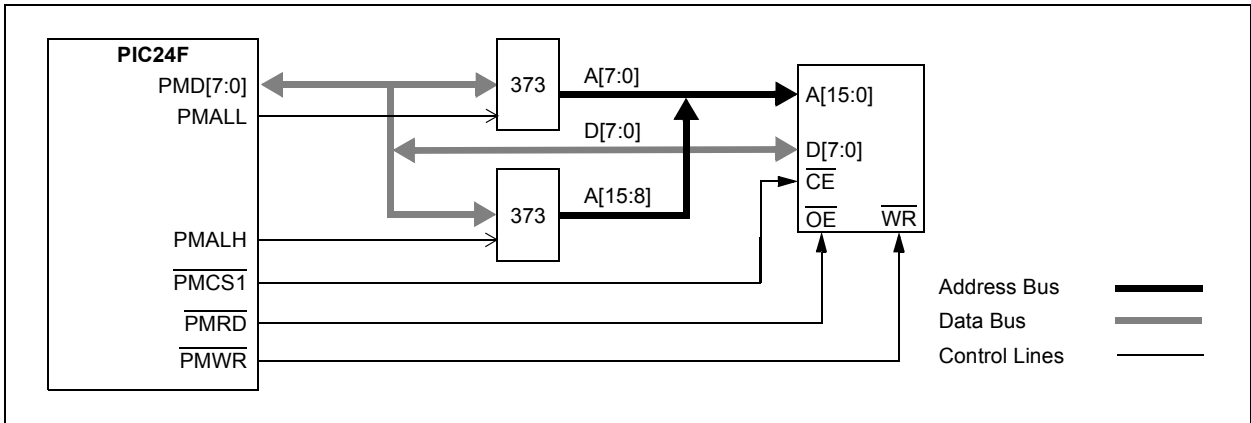
**FIGURE 18-5: MASTER MODE, PARTIALLY MULTIPLEXED ADDRESSING (SEPARATE READ AND WRITE STROBES, TWO CHIP SELECTS)**



**FIGURE 18-6: MASTER MODE, FULLY MULTIPLEXED ADDRESSING (SEPARATE READ AND WRITE STROBES, TWO CHIP SELECTS)**

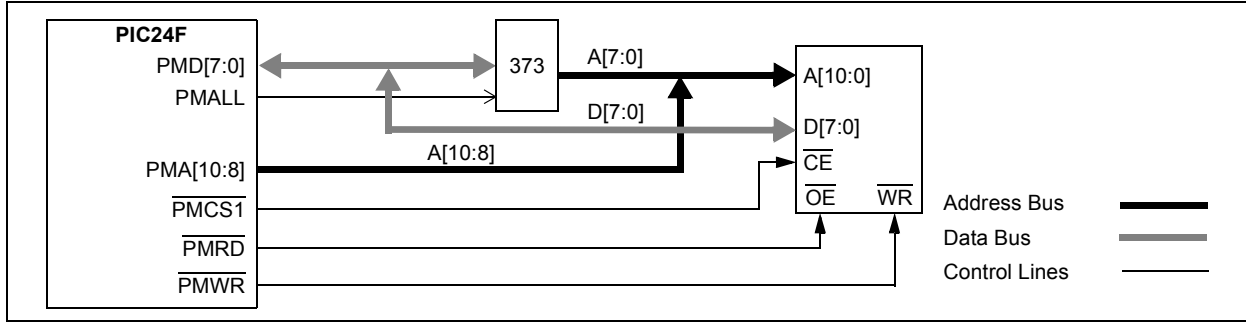


**FIGURE 18-7: EXAMPLE OF A MULTIPLEXED ADDRESSING APPLICATION**

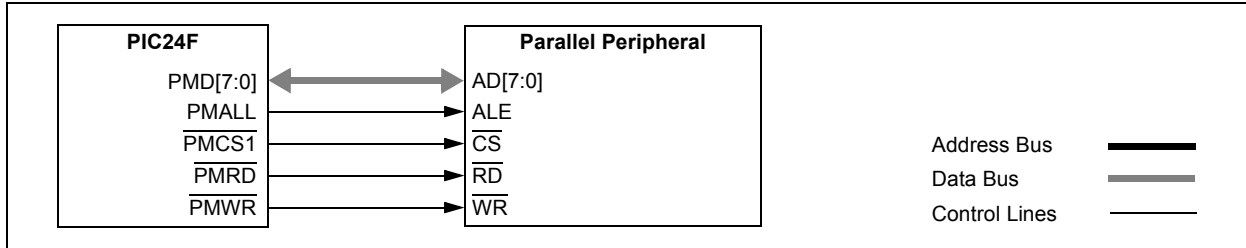


# PIC24FJ256GA110 FAMILY

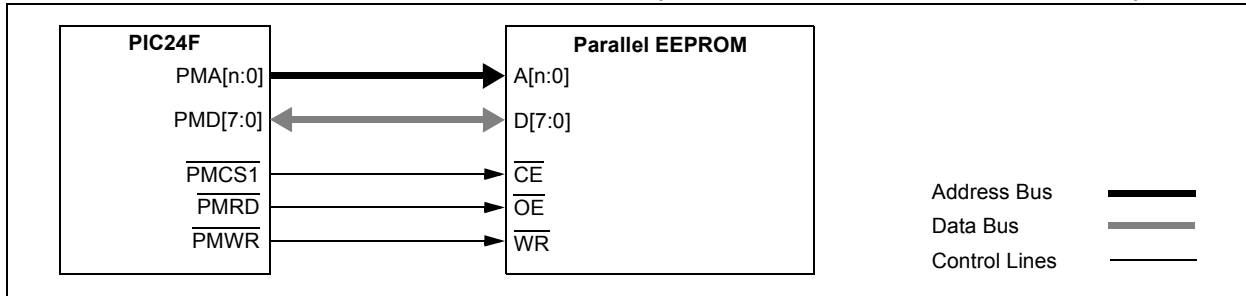
**FIGURE 18-8: EXAMPLE OF A PARTIALLY MULTIPLEXED ADDRESSING APPLICATION**



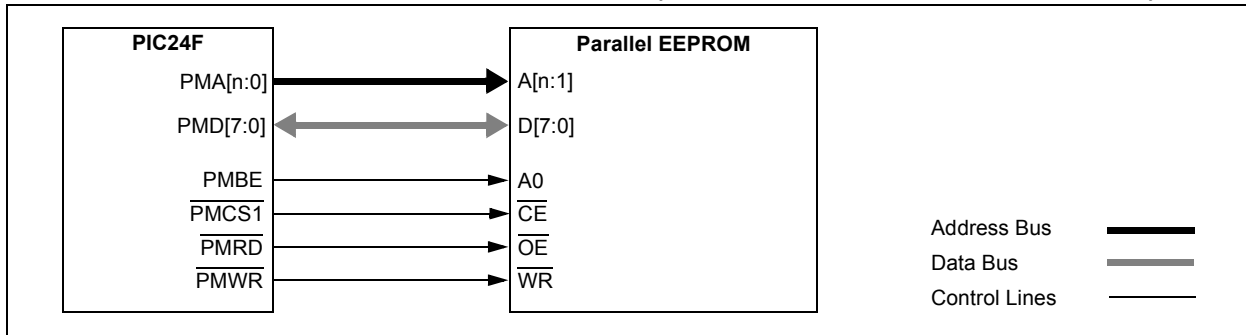
**FIGURE 18-9: EXAMPLE OF AN 8-BIT MULTIPLEXED ADDRESS AND DATA APPLICATION**



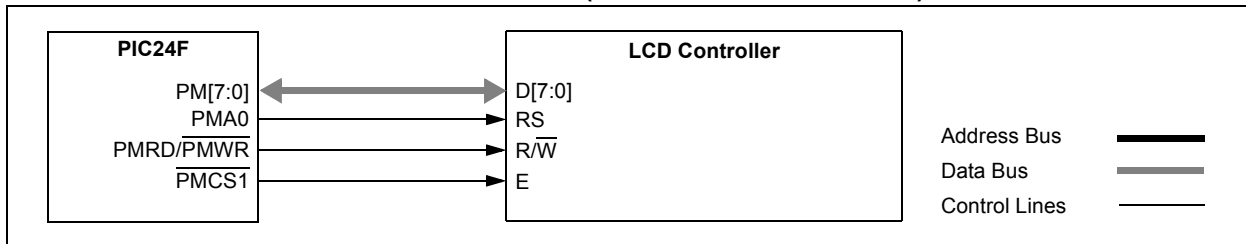
**FIGURE 18-10: PARALLEL EEPROM EXAMPLE (UP TO 15-BIT ADDRESS, 8-BIT DATA)**



**FIGURE 18-11: PARALLEL EEPROM EXAMPLE (UP TO 15-BIT ADDRESS, 16-BIT DATA)**



**FIGURE 18-12: LCD CONTROL EXAMPLE (BYTE MODE OPERATION)**



# PIC24FJ256GA110 FAMILY

## 19.0 REAL-TIME CLOCK AND CALENDAR (RTCC)

**Note:** This data sheet summarizes the features of this group of PIC24F devices. It is not intended to be a comprehensive reference source. For more information, refer to “Real-Time Clock and Calendar (RTCC)” ([www.microchip.com/DS39696](http://www.microchip.com/DS39696)) in the “dsPIC33/PIC24 Family Reference Manual”. The information in this data sheet supersedes the information in the FRM.

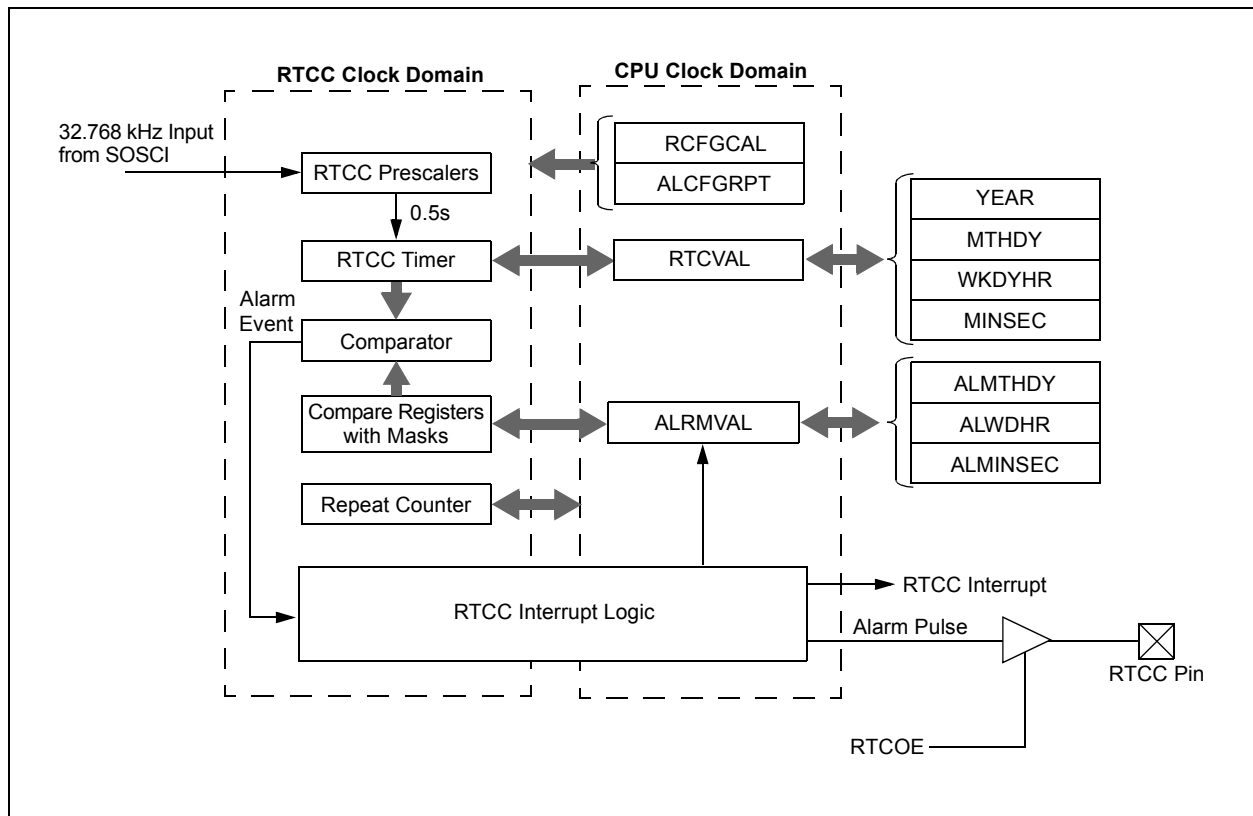
The Real-Time Clock and Calendar (RTCC) provides on-chip, hardware-based clock and calendar functionality with little or no CPU overhead. It is intended for applications where accurate time must be maintained for extended periods with minimal CPU activity and with limited power resources, such as battery-powered applications.

Key features include:

- Time Data in Hours, Minutes and Seconds, with a Granularity of One-Half Second
- 24-Hour Format (military time) Display Option
- Calendar Data as Date, Month and Year
- Automatic, Hardware-Based Day of Week and Leap Year Calculations for Dates from 2000 through 2099
- Time and Calendar Data in BCD Format for Compact Firmware
- Highly Configurable Alarm Function
- External Output Pin with Selectable Alarm Signal or Seconds “tick” Signal Output
- User Calibration Feature with Auto-Adjust

A simplified block diagram of the module is shown in Figure 19-1. The SOSC and RTCC will both remain running while the device is held in Reset with MCLR and will continue running after MCLR is released.

FIGURE 19-1: RTCC BLOCK DIAGRAM



# PIC24FJ256GA110 FAMILY

## 19.1 RTCC Module Registers

The RTCC module registers are organized into three categories:

- RTCC Control Registers
- RTCC Value Registers
- Alarm Value Registers

### 19.1.1 REGISTER MAPPING

To limit the register interface, the RTCC Timer and Alarm Time registers are accessed through corresponding register pointers. The RTCC Value register window (RTCVALH and RTCVALL) uses the RTCPTRx bits (RCFGCAL[9:8]) to select the desired Timer register pair (see [Table 19-1](#)).

By writing to the RTCVALH byte, the RTCC Pointer value, RTCPTR[1:0] bits, decrement by one until they reach '00'. Once they reach '00', the MINUTES and SECONDS value will be accessible through RTCVALH and RTCVALL until the pointer value is manually changed.

**TABLE 19-1: RTCVAL REGISTER MAPPING**

RTCPTR [1:0]	RTCC Value Register Window	
	RTCVAL[15:8]	RTCVAL[7:0]
00	MINUTES	SECONDS
01	WEEKDAY	HOURS
10	MONTH	DAY
11	—	YEAR

The Alarm Value register window (ALRMVALH and ALRMVALL) uses the ALRMPTRx bits (ALCFGRPT[9:8]) to select the desired Alarm register pair (see [Table 19-2](#)).

By writing to the ALRMVALH byte, the Alarm Pointer value, ALRMPTR[1:0] bits, decrement by one until they reach '00'. Once they reach '00', the ALRMMIN and ALRMSEC value will be accessible through ALRMVALH and ALRMVALL until the pointer value is manually changed.

**TABLE 19-2: ALRMVAL REGISTER MAPPING**

ALRMPTR [1:0]	Alarm Value Register Window	
	ALRMVAL[15:8]	ALRMVAL[7:0]
00	ALRMMIN	ALRMSEC
01	ALRMWD	ALRMHR
10	ALRMMNTH	ALRMDAY
11	—	—

Considering that the 16-bit core does not distinguish between 8-bit and 16-bit read operations, the user must be aware that when reading either the ALRMVALH or ALRMVALL bytes will decrement the ALRMPTR[1:0] value. The same applies to the RTCVALH or RTCVALL bytes with the RTCPTR[1:0] being decremented.

**Note:** This only applies to read operations and not write operations.

### 19.1.2 WRITE LOCK

In order to perform a write to any of the RTCC Timer registers, the RTCWREN bit (RCFGCAL[13]) must be set (refer to [Example 19-1](#)).

**Note:** To avoid accidental writes to the timer, it is recommended that the RTCWREN bit (RCFGCAL[13]) is kept clear at any other time. For the RTCWREN bit to be set, there is only 1 instruction cycle time window allowed between the unlock sequence and the setting of RTCWREN; therefore, it is recommended that code follow the procedure in [Example 19-1](#).

For applications written in C, the unlock sequence should be implemented using in-line assembly.

**EXAMPLE 19-1: SETTING THE RTCWREN BIT**

```
asm volatile("disi #5");
__builtin_write_RTCWREN();
```

# PIC24FJ256GA110 FAMILY

## 19.1.3 RTCC CONTROL REGISTERS

### REGISTER 19-1: RCFGAL: RTCC CALIBRATION AND CONFIGURATION REGISTER<sup>(1)</sup>

R/W-x	U-x	R/W-x	R-x	R-x	R/W-x	R/W-x	R/W-x
RTCEN <sup>(2)</sup>	—	RTCWREN	RTCSYNC	HALFSEC <sup>(3)</sup>	RTCOE	RTCPTR1	RTCPTR0
bit 15							bit 8

R/W-x	R/W-x	R/W-x	R/W-x	R/W-x	R/W-x	R/W-x	R/W-x
CAL[7:0]							
bit 7							bit 0

#### Legend:

R = Readable bit                      W = Writable bit                      U = Unimplemented bit, read as '0'  
 -n = Value at POR                      '1' = Bit is set                      '0' = Bit is cleared                      x = Bit is unknown

- bit 15        **RTCEN:** RTCC Enable bit<sup>(2)</sup>  
                  1 = RTCC module is enabled  
                  0 = RTCC module is disabled
- bit 14        **Unimplemented:** Read as '0'
- bit 13        **RTCWREN:** RTCC Value Registers Write Enable bit  
                  1 = RTCVALH and RTCVALL registers can be written to by the user  
                  0 = RTCVALH and RTCVALL registers are locked out from being written to by the user
- bit 12        **RTCSYNC:** RTCC Value Registers Read Synchronization bit  
                  1 = RTCVALH, RTCVALL and ALCFGRPT registers can change while reading due to a rollover ripple resulting in an invalid data read; if the register is read twice and results in the same data, the data can be assumed to be valid.  
                  0 = RTCVALH, RTCVALL or ALCFGRPT registers can be read without concern over a rollover ripple
- bit 11        **HALFSEC:** Half-Second Status bit<sup>(3)</sup>  
                  1 = Second half period of a second  
                  0 = First half period of a second
- bit 10        **RTCOE:** RTCC Output Enable bit  
                  1 = RTCC output enabled  
                  0 = RTCC output disabled
- bit 9-8       **RTCPTR[1:0]:** RTCC Value Register Window Pointer bits  
                  Points to the corresponding RTCC Value registers when reading the RTCVALH and RTCVALL registers; the RTCPTR[1:0] value decrements on every read or write of RTCVALH until it reaches '00'.  
                  RTCVAL[15:8]:  
                  00 = MINUTES  
                  01 = WEEKDAY  
                  10 = MONTH  
                  11 = Reserved  
                  RTCVAL[7:0]:  
                  00 = SECONDS  
                  01 = HOURS  
                  10 = DAY  
                  11 = YEAR

- Note 1:** The RCFGAL register is only affected by a POR.  
**2:** A write to the RTCEN bit is only allowed when RTCWREN = 1.  
**3:** This bit is read-only; it is cleared to '0' on a write to the lower half of the MINSEC register.

# PIC24FJ256GA110 FAMILY

## REGISTER 19-1: RCFGAL: RTCC CALIBRATION AND CONFIGURATION REGISTER<sup>(1)</sup> (CONTINUED)

bit 7-0      **CAL[7:0]:** RTC Drift Calibration bits  
 01111111 = Maximum positive adjustment; adds 508 RTC clock pulses every one minute  
 ...  
 00000001 = Minimum positive adjustment; adds 4 RTC clock pulses every one minute  
 00000000 = No adjustment  
 11111111 = Minimum negative adjustment; subtracts 4 RTC clock pulses every one minute  
 ...  
 10000000 = Maximum negative adjustment; subtracts 512 RTC clock pulses every one minute

- Note 1:** The RCFGAL register is only affected by a POR.  
**Note 2:** A write to the RTCEN bit is only allowed when RTCWREN = 1.  
**Note 3:** This bit is read-only; it is cleared to '0' on a write to the lower half of the MINSEC register.

## REGISTER 19-2: PADCFG1: PAD CONFIGURATION CONTROL REGISTER

U-0	U-0	U-0	U-0	U-0	U-0	U-0	U-0
—	—	—	—	—	—	—	—
bit 15							bit 8

U-0	U-0	U-0	U-0	U-0	U-0	R/W-0	R/W-0
—	—	—	—	—	—	RTSECSEL <sup>(1)</sup>	PMPTTL
bit 7						bit 0	

### Legend:

R = Readable bit                      W = Writable bit                      U = Unimplemented bit, read as '0'  
 -n = Value at POR                      '1' = Bit is set                      '0' = Bit is cleared                      x = Bit is unknown

bit 15-2      **Unimplemented:** Read as '0'  
 bit 1      **RTSECSEL:** RTCC Seconds Clock Output Select bit<sup>(1)</sup>  
 1 = RTCC seconds clock is selected for the RTCC pin  
 0 = RTCC alarm pulse is selected for the RTCC pin  
 bit 0      **PMPTTL:** PMP Module TTL Input Buffer Select bit  
 1 = PMP module inputs (PMDx, PMCS1) use TTL input buffers  
 0 = PMP module inputs use Schmitt Trigger input buffers

- Note 1:** To enable the actual RTCC output, the RTCOE (RCFGAL[10]) bit must also be set.

# PIC24FJ256GA110 FAMILY

## REGISTER 19-3: ALCFGRPT: ALARM CONFIGURATION REGISTER

R/W-0	R/W-0	R/W-0	R/W-0	R/W-0	R/W-0	R/W-0	R/W-0
ALRMEN	CHIME	AMASK3	AMASK2	AMASK1	AMASK0	ALRMPTR1	ALRMPTR0
bit 15						bit 8	

R/W-0	R/W-0	R/W-0	R/W-0	R/W-0	R/W-0	R/W-0	R/W-0
ARPT[7:0]							
bit 7						bit 0	

### Legend:

R = Readable bit	W = Writable bit	U = Unimplemented bit, read as '0'
-n = Value at POR	'1' = Bit is set	'0' = Bit is cleared
		x = Bit is unknown

- bit 15     **ALRMEN:** Alarm Enable bit  
 1 = Alarm is enabled (cleared automatically after an alarm event whenever ARPT[7:0] = 00h and CHIME = 0)  
 0 = Alarm is disabled
- bit 14     **CHIME:** Chime Enable bit  
 1 = Chime is enabled; ARPT[7:0] bits are allowed to roll over from 00h to FFh  
 0 = Chime is disabled; ARPT[7:0] bits stop once they reach 00h
- bit 13-10   **AMASK[3:0]:** Alarm Mask Configuration bits  
 0000 = Every half second  
 0001 = Every second  
 0010 = Every ten seconds  
 0011 = Every minute  
 0100 = Every ten minutes  
 0101 = Every hour  
 0110 = Once a day  
 0111 = Once a week  
 1000 = Once a month  
 1001 = Once a year (except when configured for February 29th, once every four years)  
 101x = Reserved; do not use  
 11xx = Reserved; do not use
- bit 9-8     **ALRMPTR[1:0]:** Alarm Value Register Window Pointer bits  
 Points to the corresponding Alarm Value registers when reading ALRMVALH and ALRMVALL registers; the ALRMPTR[1:0] value decrements on every read or write of ALRMVALH until it reaches '00'.  
ALRMVAL[15:8]:  
 00 = ALRMMIN  
 01 = ALRMWD  
 10 = ALRMMNTH  
 11 = Unimplemented  
ALRMVAL[7:0]:  
 00 = ALRMSEC  
 01 = ALRMHR  
 10 = ALRMDAY  
 11 = Unimplemented
- bit 7-0     **ARPT[7:0]:** Alarm Repeat Counter Value bits  
 11111111 = Alarm will repeat 255 more times  
 ...  
 00000000 = Alarm will not repeat  
 The counter decrements on any alarm event. The counter is prevented from rolling over, from 00h to FFh, unless CHIME = 1.

# PIC24FJ256GA110 FAMILY

## 19.1.4 RTCVAL REGISTER MAPPINGS

### REGISTER 19-4: YEAR: YEAR VALUE REGISTER<sup>(1)</sup>

U-0	U-0	U-0	U-0	U-0	U-0	U-0	U-0
—	—	—	—	—	—	—	—
bit 15							bit 8

R/W-x	R/W-x	R/W-x	R/W-x	R/W-x	R/W-x	R/W-x	R/W-x
YRTEN3	YRTEN2	YRTEN1	YRTEN0	YRONE3	YRONE2	YRONE1	YRONE0
bit 7							bit 0

#### Legend:

R = Readable bit

W = Writable bit

U = Unimplemented bit, read as '0'

-n = Value at POR

'1' = Bit is set

'0' = Bit is cleared

x = Bit is unknown

bit 15-8 **Unimplemented:** Read as '0'

bit 7-4 **YRTEN[3:0]:** Binary Coded Decimal Value of Year's Tens Digit bits  
Contains a value from 0 to 9.

bit 3-0 **YRONE[3:0]:** Binary Coded Decimal Value of Year's Ones Digit bits  
Contains a value from 0 to 9.

**Note 1:** A write to the YEAR register is only allowed when RTCWREN = 1.

### REGISTER 19-5: MTHDY: MONTH AND DAY VALUE REGISTER<sup>(1)</sup>

U-0	U-0	U-0	R/W-x	R/W-x	R/W-x	R/W-x	R/W-x
—	—	—	MHTTEN0	MTHONE3	MTHONE2	MTHONE1	MTHONE0
bit 15							bit 8

U-0	U-0	R/W-x	R/W-x	R/W-x	R/W-x	R/W-x	R/W-x
—	—	DAYTEN1	DAYTEN0	DAYONE3	DAYONE2	DAYONE1	DAYONE0
bit 7							bit 0

#### Legend:

R = Readable bit

W = Writable bit

U = Unimplemented bit, read as '0'

-n = Value at POR

'1' = Bit is set

'0' = Bit is cleared

x = Bit is unknown

bit 15-13 **Unimplemented:** Read as '0'

bit 12 **MHTTEN0:** Binary Coded Decimal Value of Month's Tens Digit bit  
Contains a value of 0 or 1.

bit 11-8 **MTHONE[3:0]:** Binary Coded Decimal Value of Month's Ones Digit bits  
Contains a value from 0 to 9.

bit 7-6 **Unimplemented:** Read as '0'

bit 5-4 **DAYTEN[1:0]:** Binary Coded Decimal Value of Day's Tens Digit bits  
Contains a value from 0 to 3.

bit 3-0 **DAYONE[3:0]:** Binary Coded Decimal Value of Day's Ones Digit bits  
Contains a value from 0 to 9.

**Note 1:** A write to this register is only allowed when RTCWREN = 1.

# PIC24FJ256GA110 FAMILY

## REGISTER 19-6: WKDYHR: WEEKDAY AND HOURS VALUE REGISTER<sup>(1)</sup>

U-0	U-0	U-0	U-0	U-0	R/W-x	R/W-x	R/W-x
—	—	—	—	—	WDAY2	WDAY1	WDAY0
bit 15					bit 8		

U-0	U-0	R/W-x	R/W-x	R/W-x	R/W-x	R/W-x	R/W-x
—	—	HRTEN1	HRTEN0	HRONE3	HRONE2	HRONE1	HRONE0
bit 7					bit 0		

### Legend:

R = Readable bit                      W = Writable bit                      U = Unimplemented bit, read as '0'  
 -n = Value at POR                      '1' = Bit is set                      '0' = Bit is cleared                      x = Bit is unknown

- bit 15-11      **Unimplemented:** Read as '0'
- bit 10-8      **WDAY[2:0]:** Binary Coded Decimal Value of Weekday Digit bits  
Contains a value from 0 to 6.
- bit 7-6        **Unimplemented:** Read as '0'
- bit 5-4        **HRTEN[1:0]:** Binary Coded Decimal Value of Hour's Tens Digit bits  
Contains a value from 0 to 2.
- bit 3-0        **HRONE[3:0]:** Binary Coded Decimal Value of Hour's Ones Digit bits  
Contains a value from 0 to 9.

**Note 1:** A write to this register is only allowed when RTCWREN = 1.

## REGISTER 19-7: MINSEC: MINUTES AND SECONDS VALUE REGISTER

U-0	R/W-x	R/W-x	R/W-x	R/W-x	R/W-x	R/W-x	R/W-x
—	MINTEN2	MINTEN1	MINTEN0	MINONE3	MINONE2	MINONE1	MINONE0
bit 15					bit 8		

U-0	R/W-x	R/W-x	R/W-x	R/W-x	R/W-x	R/W-x	R/W-x
—	SECTEN2	SECTEN1	SECTEN0	SECONE3	SECONE2	SECONE1	SECONE0
bit 7					bit 0		

### Legend:

R = Readable bit                      W = Writable bit                      U = Unimplemented bit, read as '0'  
 -n = Value at POR                      '1' = Bit is set                      '0' = Bit is cleared                      x = Bit is unknown

- bit 15        **Unimplemented:** Read as '0'
- bit 14-12    **MINTEN[2:0]:** Binary Coded Decimal Value of Minute's Tens Digit bits  
Contains a value from 0 to 5.
- bit 11-8     **MINONE[3:0]:** Binary Coded Decimal Value of Minute's Ones Digit bits  
Contains a value from 0 to 9.
- bit 7         **Unimplemented:** Read as '0'
- bit 6-4      **SECTEN[2:0]:** Binary Coded Decimal Value of Second's Tens Digit bits  
Contains a value from 0 to 5.
- bit 3-0      **SECONE[3:0]:** Binary Coded Decimal Value of Second's Ones Digit bits  
Contains a value from 0 to 9.

# PIC24FJ256GA110 FAMILY

## 19.1.5 ALRMVAL REGISTER MAPPINGS

### REGISTER 19-8: ALMTHDY: ALARM MONTH AND DAY VALUE REGISTER<sup>(1)</sup>

U-0	U-0	U-0	R/W-x	R/W-x	R/W-x	R/W-x	R/W-x
—	—	—	MHTTEN0	MTHONE3	MTHONE2	MTHONE1	MTHONE0
bit 15							bit 8

U-0	U-0	R/W-x	R/W-x	R/W-x	R/W-x	R/W-x	R/W-x
—	—	DAYTEN1	DAYTEN0	DAYONE3	DAYONE2	DAYONE1	DAYONE0
bit 7							bit 0

#### Legend:

R = Readable bit                      W = Writable bit                      U = Unimplemented bit, read as '0'  
 -n = Value at POR                      '1' = Bit is set                      '0' = Bit is cleared                      x = Bit is unknown

- bit 15-13      **Unimplemented:** Read as '0'
- bit 12        **MHTTEN0:** Binary Coded Decimal Value of Month's Tens Digit bit  
Contains a value of 0 or 1.
- bit 11-8      **MTHONE[3:0]:** Binary Coded Decimal Value of Month's Ones Digit bits  
Contains a value from 0 to 9.
- bit 7-6       **Unimplemented:** Read as '0'
- bit 5-4       **DAYTEN[1:0]:** Binary Coded Decimal Value of Day's Tens Digit bits  
Contains a value from 0 to 3.
- bit 3-0       **DAYONE[3:0]:** Binary Coded Decimal Value of Day's Ones Digit bits  
Contains a value from 0 to 9.

**Note 1:** A write to this register is only allowed when RTCWREN = 1.

### REGISTER 19-9: ALWDHR: ALARM WEEKDAY AND HOURS VALUE REGISTER<sup>(1)</sup>

U-0	U-0	U-0	U-0	U-0	R/W-x	R/W-x	R/W-x
—	—	—	—	—	WDAY2	WDAY1	WDAY0
bit 15							bit 8

U-0	U-0	R/W-x	R/W-x	R/W-x	R/W-x	R/W-x	R/W-x
—	—	HRTEN1	HRTEN0	HRONE3	HRONE2	HRONE1	HRONE0
bit 7							bit 0

#### Legend:

R = Readable bit                      W = Writable bit                      U = Unimplemented bit, read as '0'  
 -n = Value at POR                      '1' = Bit is set                      '0' = Bit is cleared                      x = Bit is unknown

- bit 15-11      **Unimplemented:** Read as '0'
- bit 10-8      **WDAY[2:0]:** Binary Coded Decimal Value of Weekday Digit bits  
Contains a value from 0 to 6.
- bit 7-6       **Unimplemented:** Read as '0'
- bit 5-4       **HRTEN[1:0]:** Binary Coded Decimal Value of Hour's Tens Digit bits  
Contains a value from 0 to 2.
- bit 3-0       **HRONE[3:0]:** Binary Coded Decimal Value of Hour's Ones Digit bits  
Contains a value from 0 to 9.

**Note 1:** A write to this register is only allowed when RTCWREN = 1.

# PIC24FJ256GA110 FAMILY

## REGISTER 19-10: ALMINSEC: ALARM MINUTES AND SECONDS VALUE REGISTER

U-0	R/W-x	R/W-x	R/W-x	R/W-x	R/W-x	R/W-x	R/W-x
—	MINTEN2	MINTEN1	MINTEN0	MINONE3	MINONE2	MINONE1	MINONE0
bit 15							bit 8

U-0	R/W-x	R/W-x	R/W-x	R/W-x	R/W-x	R/W-x	R/W-x
—	SECTEN2	SECTEN1	SECTEN0	SECONE3	SECONE2	SECONE1	SECONE0
bit 7							bit 0

### Legend:

R = Readable bit	W = Writable bit	U = Unimplemented bit, read as '0'
-n = Value at POR	'1' = Bit is set	'0' = Bit is cleared
		x = Bit is unknown

- bit 15 **Unimplemented:** Read as '0'
- bit 14-12 **MINTEN[2:0]:** Binary Coded Decimal Value of Minute's Tens Digit bits  
Contains a value from 0 to 5.
- bit 11-8 **MINONE[3:0]:** Binary Coded Decimal Value of Minute's Ones Digit bits  
Contains a value from 0 to 9.
- bit 7 **Unimplemented:** Read as '0'
- bit 6-4 **SECTEN[2:0]:** Binary Coded Decimal Value of Second's Tens Digit bits  
Contains a value from 0 to 5.
- bit 3-0 **SECONE[3:0]:** Binary Coded Decimal Value of Second's Ones Digit bits  
Contains a value from 0 to 9.

## 19.2 Calibration

The real-time crystal input can be calibrated using the periodic auto-adjust feature. When properly calibrated, the RTCC can provide an error of less than three seconds per month. This is accomplished by finding the number of error clock pulses for one minute and storing the value into the lower half of the RCFGAL register. The 8-bit signed value loaded into the lower half of RCFGAL is multiplied by four and will be either added or subtracted from the RTCC timer, once every minute. Refer to the steps below for RTCC calibration:

- Using another timer resource on the device, the user must find the error of the 32.768 kHz crystal.
- Once the error is known, it must be converted to the number of error clock pulses per minute and loaded into the RCFGAL register.

### EQUATION 19-1: RTCC CALIBRATION

$$\text{Error (Clocks per Minute)} = (\text{Ideal Frequency} \dagger - \text{Measured Frequency}) * 60 = \text{Clocks per Minute}$$

$$\dagger \text{ Ideal frequency} = 32,768 \text{ Hz}$$

- If the oscillator is faster than ideal (negative result from Step 2), the RCFGAL register value needs to be negative. This causes the specified number of clock pulses to be subtracted from the timer counter once every minute.
  - If the oscillator is slower than ideal (positive result from Step 2) the RCFGAL register value needs to be positive. This causes the specified number of clock pulses to be added from the timer counter once every minute.
- Divide the number of error clocks per minute by four to get the correct CALx bits value and load the RCFGAL register with the correct value.  
(Each 1-bit increment in the CALx bits adds or subtracts four pulses.)

Writes to the lower half of the RCFGAL register should only occur when the timer is turned off or immediately after the rising edge of the seconds pulse.

**Note:** It is up to the user to include in the error value the initial error of the crystal, drift due to temperature and drift due to crystal aging.

# PIC24FJ256GA110 FAMILY

## 19.3 Alarm

- Configurable from half second to one year
- Enabled using the ALRMEN bit (ALCFGRPT[15], Register 19-3)
- One-time alarm and repeat alarm options available

### 19.3.1 CONFIGURING THE ALARM

The alarm feature is enabled using the ALRMEN bit. This bit is cleared when an alarm is issued. Writes to ALRMVAL should only take place when ALRMEN = 0.

As shown in Figure 19-2, the interval selection of the alarm is configured through the AMASKx bits (ALCFGRPT[13:10]). These bits determine which and how many digits of the alarm must match the clock value for the alarm to occur.

The alarm can also be configured to repeat based on a preconfigured interval. The amount of times this occurs once the alarm is enabled is stored in the ARPTx bits, ARPT[7:0] (ALCFGRPT[7:0]). When the value of the ARPTx bits equals 00h and the CHIME bit (ALCFGRPT[14]) is cleared, the repeat function is disabled and only a single alarm will occur. The alarm can be repeated up to 255 times by loading ARPT[7:0] with FFh.

After each alarm is issued, the value of the ARPTx bits is decremented by one. Once the value has reached 00h, the alarm will be issued one last time, after which the ALRMEN bit will be cleared automatically and the alarm will turn off.

Indefinite repetition of the alarm can occur if the CHIME bit = 1. Instead of the alarm being disabled when the value of the ARPTx bits reaches 00h, it rolls over to FFh and continues counting indefinitely while CHIME is set.

### 19.3.2 ALARM INTERRUPT

At every alarm event, an interrupt is generated. In addition, an alarm pulse output is provided that operates at half the frequency of the alarm. This output is completely synchronous to the RTCC clock and can be used as a trigger clock to other peripherals.

**Note:** Changing any of the registers, other than the RCFGAL and ALCFGRPT registers, and the CHIME bit while the alarm is enabled (ALRMEN = 1), can result in a false alarm event leading to a false alarm interrupt. To avoid a false alarm event, the timer and alarm values should only be changed while the alarm is disabled (ALRMEN = 0). It is recommended that the ALCFGRPT register and CHIME bit be changed when RTCSYNC = 0.

**FIGURE 19-2: ALARM MASK SETTINGS**

Alarm Mask Setting (AMASK[3:0])	Day of the Week					
	Month	Day	Hours	Minutes	Seconds	
0000 – Every half second 0001 – Every second	<input type="checkbox"/>	<input type="checkbox"/>	<input type="checkbox"/>	<input type="checkbox"/>	<input type="checkbox"/>	<input type="checkbox"/>
0010 – Every 10 seconds	<input type="checkbox"/>	<input type="checkbox"/>	<input type="checkbox"/>	<input type="checkbox"/>	<input type="checkbox"/>	<input type="checkbox"/> s
0011 – Every minute	<input type="checkbox"/>	<input type="checkbox"/>	<input type="checkbox"/>	<input type="checkbox"/>	<input type="checkbox"/>	<input type="checkbox"/> s <input type="checkbox"/> s
0100 – Every 10 minutes	<input type="checkbox"/>	<input type="checkbox"/>	<input type="checkbox"/>	<input type="checkbox"/> m	<input type="checkbox"/>	<input type="checkbox"/> s <input type="checkbox"/> s
0101 – Every hour	<input type="checkbox"/>	<input type="checkbox"/>	<input type="checkbox"/>	<input type="checkbox"/> m <input type="checkbox"/> m	<input type="checkbox"/>	<input type="checkbox"/> s <input type="checkbox"/> s
0110 – Every day	<input type="checkbox"/>	<input type="checkbox"/>	<input type="checkbox"/> h <input type="checkbox"/> h	<input type="checkbox"/> m <input type="checkbox"/> m	<input type="checkbox"/>	<input type="checkbox"/> s <input type="checkbox"/> s
0111 – Every week	<input type="checkbox"/> d	<input type="checkbox"/>	<input type="checkbox"/> h <input type="checkbox"/> h	<input type="checkbox"/> m <input type="checkbox"/> m	<input type="checkbox"/>	<input type="checkbox"/> s <input type="checkbox"/> s
1000 – Every month	<input type="checkbox"/>	<input type="checkbox"/>	<input type="checkbox"/> d <input type="checkbox"/> d	<input type="checkbox"/> h <input type="checkbox"/> h	<input type="checkbox"/>	<input type="checkbox"/> s <input type="checkbox"/> s
1001 – Every year <sup>(1)</sup>	<input type="checkbox"/>	<input type="checkbox"/> m <input type="checkbox"/> m	<input type="checkbox"/> d <input type="checkbox"/> d	<input type="checkbox"/> h <input type="checkbox"/> h	<input type="checkbox"/>	<input type="checkbox"/> s <input type="checkbox"/> s

**Note 1:** Annually, except when configured for February 29.

# PIC24FJ256GA110 FAMILY

## 20.0 PROGRAMMABLE CYCLIC REDUNDANCY CHECK (CRC) GENERATOR

**Note:** This data sheet summarizes the features of this group of PIC24F devices. It is not intended to be a comprehensive reference source. For more information, refer to “Programmable Cyclic Redundancy Check (CRC)” ([www.microchip.com/DS39714](http://www.microchip.com/DS39714)) in the “dsPIC33/PIC24 Family Reference Manual”. The information in this data sheet supersedes the information in the FRM.

The programmable CRC generator offers the following features:

- User-Programmable Polynomial CRC Equation
- Interrupt Output
- Data FIFO

The module implements a software configurable CRC generator. The terms of the polynomial and its length can be programmed using the X[15:1] bits (CRCXOR[15:1]) and the PLEN[3:0] bits (CRCCON[3:0]), respectively.

Consider the CRC equation:

$$x^{16} + x^{12} + x^5 + 1$$

To program this polynomial into the CRC generator, the CRC register bits should be set as shown in Table 20-1.

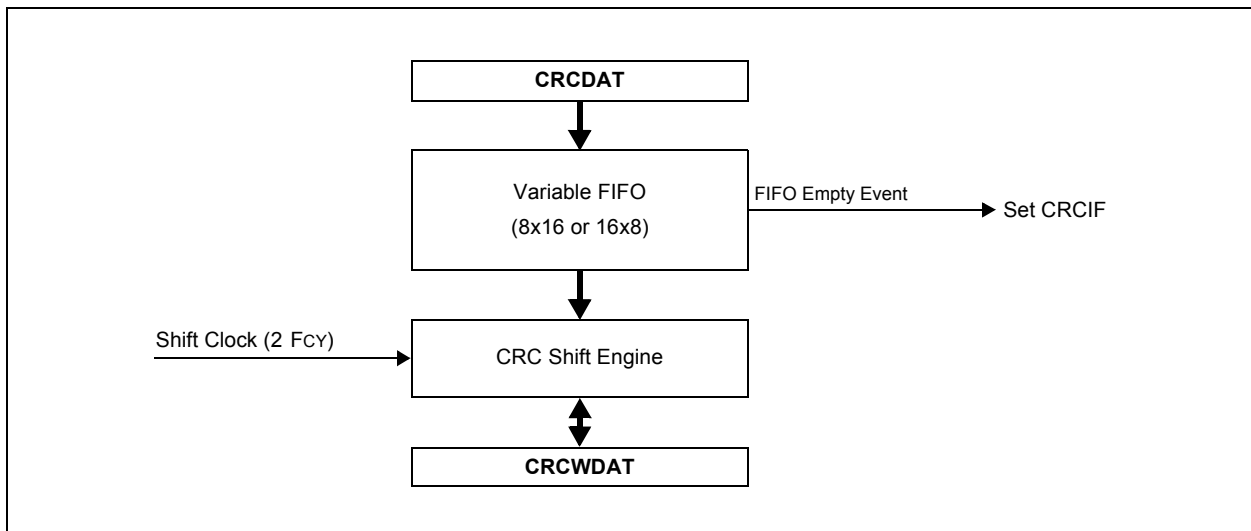
**TABLE 20-1: EXAMPLE CRC SETUP**

Bit Name	Bit Value
PLEN[3:0]	1111
X[15:1]	000100000010000

Note that for the value of X[15:1], the 12th bit and the 5th bit are set to '1', as required by the equation. The 0 bit required by the equation is always XORed. For a 16-bit polynomial, the 16th bit is also always assumed to be XORed; therefore, the X[15:1] bits do not have the 0 bit or the 16th bit.

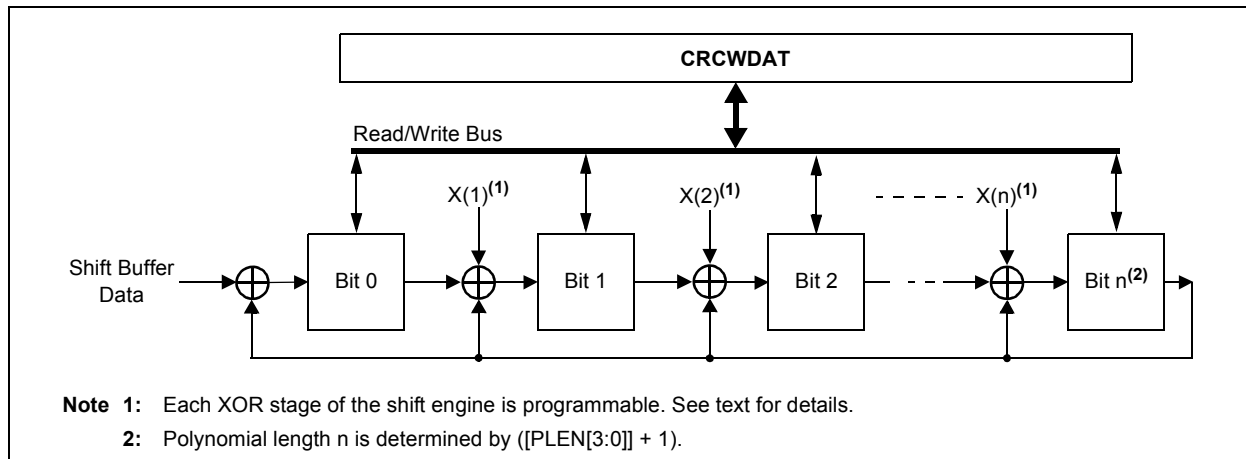
A simplified block diagram of the module is shown in Figure 20-1. The general topology of the shift engine is shown in Figure 20-2.

**FIGURE 20-1: CRC BLOCK DIAGRAM**



# PIC24FJ256GA110 FAMILY

**FIGURE 20-2: CRC SHIFT ENGINE DETAIL**



## 20.1 User Interface

### 20.1.1 DATA INTERFACE

To start serial shifting, a '1' must be written to the CRCGO bit.

The module incorporates a FIFO that is 8 deep when  $PLEN[3:0]$  ( $CRCCON[3:0]$ )  $> 7$  and 16 deep, otherwise. The data for which the CRC is to be calculated must first be written into the FIFO. The smallest data element that can be written into the FIFO is one byte. For example, if  $PLENx = 5$ , then the size of the data is  $PLENx + 1 = 6$ . When loading data, the two MSBs of the data byte are ignored.

Once data are written into the CRCWDAT MSb (as defined by  $PLENx$ ), the value of  $VWORD[4:0]$  ( $CRCCON[12:8]$ ) increments by one. When  $CRCGO = 1$  and  $VWORDx > 0$ , a word of data to be shifted is moved from the FIFO into the shift engine. When the data word moves from the FIFO to the shift engine, the  $VWORDx$  bits decrement by one. The serial shifter continues to receive data from the FIFO, shifting until the  $VWORDx$  bits reach 0. The last bit of data will be shifted through the CRC module  $(PLENx + 1)/2$  clock cycles after the  $VWORDx$  bits reach '0'. This is when the module is completed with the CRC calculation.

Therefore, for a given value of  $PLENx$ , it will take  $(PLENx + 1)/2 * VWORDx$  number of clock cycles to complete the CRC calculations.

When the  $VWORD[4:0]$  bits reach 8 (or 16), the  $CRCFUL$  bit will be set. When the  $VWORD[4:0]$  bits reach '0', the  $CRCMPT$  bit will be set.

To continually feed data into the CRC engine, the recommended mode of operation is to initially "prime" the FIFO with a sufficient number of words, so no interrupt is generated before the next word can be written. Once that is done, start the CRC by setting the  $CRCGO$  bit to '1'. From that point onward, the  $VWORDx$  bits should be polled. If they read less than 8 or 16, another word can be written into the FIFO.

To empty words already written into a FIFO, the  $CRCGO$  bit must be set to '1' and the CRC shifter allowed to run until the  $CRCMPT$  bit is set.

Also, to get the correct CRC reading, it will be necessary to wait for the  $CRCMPT$  bit to go high before reading the  $CRCWDAT$  register.

If a word is written when the  $CRCFUL$  bit is set, the  $VWORDx$  Pointer will roll over to '0'. The hardware will then behave as if the FIFO is empty. However, the condition to generate an interrupt will not be met; therefore, no interrupt will be generated (See [Section 20.1.2 "Interrupt Operation"](#)).

At least one instruction cycle must pass after a write to  $CRCWDAT$  before a read of the  $VWORDx$  bits is done.

### 20.1.2 INTERRUPT OPERATION

When the  $VWORD[4:0]$  bits make a transition from a value of '1' to '0', an interrupt will be generated. Note that the CRC calculation is not complete at this point; an additional time of  $(PLENx + 1)/2$  clock cycles is required before the output can be read.

## 20.2 Operation in Power Save Modes

### 20.2.1 SLEEP MODE

If Sleep mode is entered while the module is operating, the module will be suspended in its current state until clock execution resumes.

### 20.2.2 IDLE MODE

To continue full module operation in Idle mode, the  $CSIDL$  bit must be cleared prior to entry into the mode.

If  $CSIDL = 1$ , the module will behave the same way as it does in Sleep mode; pending interrupt events will be passed on, even though the module clocks are not available.

# PIC24FJ256GA110 FAMILY

## 20.3 Registers

There are four registers used to control programmable CRC operation:

- CRCCON
- CRCXOR
- CRCDAT
- CRCWDAT

### REGISTER 20-1: CRCCON: CRC CONTROL REGISTER

U-0	U-0	R/W-0	R-0	R-0	R-0	R-0	R-0
—	—	CSIDL	VWORD4	VWORD3	VWORD2	VWORD1	VWORD0
bit 15							bit 8

R-0	R-1	U-0	R/W-0	R/W-0	R/W-0	R/W-0	R/W-0
CRCFUL	CRCMPT	—	CRCGO	PLEN3	PLEN2	PLEN1	PLEN0
bit 7							bit 0

#### Legend:

R = Readable bit  
-n = Value at POR

W = Writable bit  
'1' = Bit is set

U = Unimplemented bit, read as '0'  
'0' = Bit is cleared

x = Bit is unknown

bit 15-14 **Unimplemented:** Read as '0'

bit 13 **CSIDL:** CRC Stop in Idle Mode bit

- 1 = Discontinues module operation when device enters Idle mode
- 0 = Continues module operation in Idle mode

bit 12-8 **VWORD[4:0]:** Pointer Value bits

Indicates the number of valid words in the FIFO. Has a maximum value of 8 when PLEN[3:0] > 7 or 16 when PLEN[3:0] ≤ 7.

bit 7 **CRCFUL:** FIFO Full bit

- 1 = FIFO is full
- 0 = FIFO is not full

bit 6 **CRCMPT:** FIFO Empty Bit

- 1 = FIFO is empty
- 0 = FIFO is not empty

bit 5 **Unimplemented:** Read as '0'

bit 4 **CRCGO:** Start CRC bit

- 1 = Start CRC serial shifter
- 0 = CRC serial shifter turned off

bit 3-0 **PLEN[3:0]:** Polynomial Length bits

Denotes the length of the polynomial to be generated minus 1.

# PIC24FJ256GA110 FAMILY

## REGISTER 20-2: CRCXOR: CRC XOR POLYNOMIAL REGISTER

R/W-0	R/W-0	R/W-0	R/W-0	R/W-0	R/W-0	R/W-0	R/W-0
X[15:8]							
bit 15							
bit 8							

R/W-0	R/W-0	R/W-0	R/W-0	R/W-0	R/W-0	R/W-0	U-0
X[7:1]							—
bit 7							
bit 0							

**Legend:**

R = Readable bit	W = Writable bit	U = Unimplemented bit, read as '0'
-n = Value at POR	'1' = Bit is set	'0' = Bit is cleared
		x = Bit is unknown

bit 15-1     **X[15:1]:** XOR of Polynomial Term  $X^n$  Enable bits

bit 0         **Unimplemented:** Read as '0'

## 21.0 10-BIT HIGH-SPEED A/D CONVERTER

**Note:** This data sheet summarizes the features of this group of PIC24F devices. It is not intended to be a comprehensive reference source. For more information, refer to “**10-Bit A/D Converter**” ([www.microchip.com/DS39705](http://www.microchip.com/DS39705)) in the “*dsPIC33/PIC24 Family Reference Manual*”. The information in this data sheet supersedes the information in the FRM.

The 10-bit A/D Converter has the following key features:

- Successive Approximation (SAR) Conversion
- Conversion Speeds of Up to 500 ksp/s
- 16 Analog Input Pins
- External Voltage Reference Input pins
- Internal Band Gap Reference Inputs
- Automatic Channel Scan mode
- Selectable Conversion Trigger Source
- 16-Word Conversion Result Buffer
- Selectable Buffer Fill modes
- Four Result Alignment Options
- Operation during CPU Sleep and Idle modes

On all PIC24FJ256GA110 family devices, the 10-bit A/D Converter has 16 analog input pins, designated AN0 through AN15. In addition, there are two analog input pins for external voltage reference connections (VREF+ and VREF-). These voltage reference inputs may be shared with other analog input pins.

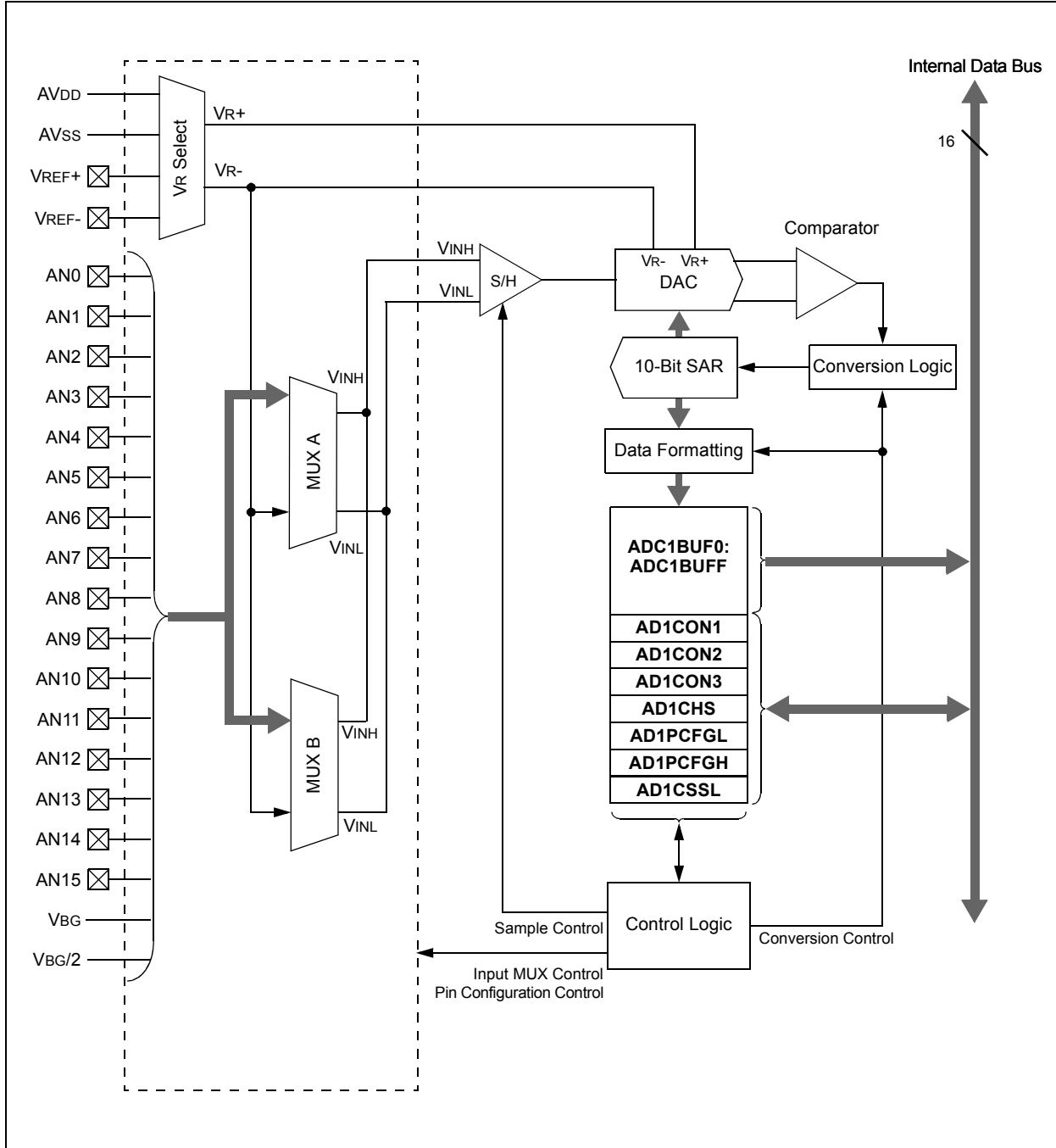
A block diagram of the A/D Converter is shown in [Figure 21-1](#).

To perform an A/D conversion:

1. Configure the A/D module:
  - a) Configure port pins as analog inputs and/or select the band gap reference input (AD1PCFGL[15:0] and AD1PCFGH[1:0]).
  - b) Select the voltage reference source to match expected range on analog inputs (AD1CON2[15:13]).
  - c) Select the analog conversion clock to match the desired data rate with the processor clock (AD1CON3[7:0]).
  - d) Select the appropriate sample/conversion sequence (AD1CON1[7:5] and AD1CON3[12:8]).
  - e) Select how conversion results are presented in the buffer (AD1CON1[9:8]).
  - f) Select the interrupt rate (AD1CON2[5:2]).
  - g) Turn on the A/D module (AD1CON1[15]).
2. Configure the A/D interrupt (if required):
  - a) Clear the AD1IF bit.
  - b) Select the A/D interrupt priority.

# PIC24FJ256GA110 FAMILY

FIGURE 21-1: 10-BIT HIGH-SPEED A/D CONVERTER BLOCK DIAGRAM



# PIC24FJ256GA110 FAMILY

## REGISTER 21-1: AD1CON1: A/D CONTROL REGISTER 1

R/W-0	U-0	R/W-0	U-0	U-0	U-0	R/W-0	R/W-0
ADON <sup>(1)</sup>	—	ADSIDL	—	—	—	FORM1	FORM0
bit 15						bit 8	

R/W-0	R/W-0	R/W-0	U-0	U-0	R/W-0	HCS/R/W-0	HCS/R-0
SSRC2	SSRC1	SSRC0	—	—	ASAM	SAMP	DONE
bit 7						bit 0	

<b>Legend:</b>	HCS = Hardware Clearable/Settable bit		
R = Readable bit	W = Writable bit	U = Unimplemented bit, read as '0'	
-n = Value at POR	'1' = Bit is set	'0' = Bit is cleared	x = Bit is unknown

- bit 15      **ADON:** A/D Operating Mode bit<sup>(1)</sup>  
             1 = A/D Converter module is operating  
             0 = A/D Converter is off
- bit 14      **Unimplemented:** Read as '0'
- bit 13      **ADSIDL:** Stop in Idle Mode bit  
             1 = Discontinues module operation when device enters Idle mode  
             0 = Continues module operation in Idle mode
- bit 12-10   **Unimplemented:** Read as '0'
- bit 9-8     **FORM[1:0]:** Data Output Format bits  
             11 = Signed fractional (sddd dddd dd00 0000)  
             10 = Fractional (dddd dddd dd00 0000)  
             01 = Signed integer (ssss sssd dddd dddd)  
             00 = Integer (0000 00dd dddd dddd)
- bit 7-5     **SSRC[2:0]:** Conversion Trigger Source Select bits  
             111 = Internal counter ends sampling and starts conversion (auto-convert)  
             110 = CTMU event ends sampling and starts conversion  
             101 = Reserved  
             100 = Timer5 compare ends sampling and starts conversion  
             011 = Reserved  
             010 = Timer3 compare ends sampling and starts conversion  
             001 = Active transition on INT0 pin ends sampling and starts conversion  
             000 = Clearing SAMP bit ends sampling and starts conversion
- bit 4-3     **Unimplemented:** Read as '0'
- bit 2       **ASAM:** A/D Sample Auto-Start bit  
             1 = Sampling begins immediately after last conversion completes; SAMP bit is auto-set  
             0 = Sampling begins when the SAMP bit is set
- bit 1       **SAMP:** A/D Sample Enable bit  
             1 = A/D Sample-and-Hold (S/H) amplifier is sampling input  
             0 = A/D Sample-and-Hold amplifier is holding
- bit 0       **DONE:** A/D Conversion Status bit  
             1 = A/D conversion is done  
             0 = A/D conversion is NOT done

**Note 1:** Values of ADC1BUFx registers will not retain their values once the ADON bit is cleared. Read out the conversion values from the buffer before disabling the module.

# PIC24FJ256GA110 FAMILY

## REGISTER 21-2: AD1CON2: A/D CONTROL REGISTER 2

R/W-0	R/W-0	R/W-0	r-0	U-0	R/W-0	U-0	U-0
VCFG2	VCFG1	VCFG0	—	—	CSCNA	—	—
bit 15						bit 8	

R-0	U-0	R/W-0	R/W-0	R/W-0	R/W-0	R/W-0	R/W-0
BUFS	—	SMPI3	SMPI2	SMPI1	SMPI0	BUFM	ALTS
bit 7						bit 0	

<b>Legend:</b>	r = Reserved bit	U = Unimplemented bit, read as '0'
R = Readable bit	W = Writable bit	'0' = Bit is cleared
-n = Value at POR	'1' = Bit is set	x = Bit is unknown

bit 15-13 **VCFG[2:0]:** Voltage Reference Configuration bits

VCFG[2:0]	VR+	VR-
000	AVDD	AVSS
001	External VREF+ Pin	AVSS
010	AVDD	External VREF- Pin
011	External VREF+ Pin	External VREF- Pin
1xx	AVDD	AVSS

bit 12 **Reserved:** Maintain as '0'

bit 11 **Unimplemented:** Read as '0'

bit 10 **CSCNA:** Scan Input Selections for S/H Positive Input for MUX A Input Multiplexer Setting bit  
 1 = Scans inputs  
 0 = Does not scan inputs

bit 9-8 **Unimplemented:** Read as '0'

bit 7 **BUFS:** Buffer Fill Status bit (valid only when BUFM = 1)  
 1 = A/D is currently filling Buffer 08-0F, user should access data in 00-07  
 0 = A/D is currently filling Buffer 00-07, user should access data in 08-0F

bit 6 **Unimplemented:** Read as '0'

bit 5-2 **SMPI[3:0]:** Sample/Convert Sequences Per Interrupt Selection bits  
 1111 = Interrupts at the completion of conversion for each 16th sample/convert sequence  
 1110 = Interrupts at the completion of conversion for each 15th sample/convert sequence  
 ...  
 0001 = Interrupts at the completion of conversion for each 2nd sample/convert sequence  
 0000 = Interrupts at the completion of conversion for each sample/convert sequence

bit 1 **BUFM:** Buffer Mode Select bit  
 1 = Buffer configured as two 8-word buffers (ADC1BUFn[15:8] and ADC1BUFn[7:0])  
 0 = Buffer configured as one 16-word buffer (ADC1BUFn[15:0])

bit 0 **ALTS:** Alternate Input Sample Mode Select bit  
 1 = Uses MUX A input multiplexer settings for first sample, then alternates between MUX B and MUX A input multiplexer settings for all subsequent samples  
 0 = Always uses MUX A input multiplexer settings

# PIC24FJ256GA110 FAMILY

## REGISTER 21-3: AD1CON3: A/D CONTROL REGISTER 3

R/W-0	r-0	r-0	R/W-0	R/W-0	R/W-0	R/W-0	R/W-0
ADRC	—	—	SAMC[4:0]				
bit 15							bit 8

R/W-0	R/W-0	R/W-0	R/W-0	R/W-0	R/W-0	R/W-0	R/W-0
ADCS[7:0]							
bit 7							bit 0

<b>Legend:</b>	r = Reserved bit	U = Unimplemented bit, read as '0'
R = Readable bit	W = Writable bit	'0' = Bit is cleared
-n = Value at POR	'1' = Bit is set	x = Bit is unknown

bit 15      **ADRC:** A/D Conversion Clock Source bit

- 1 = A/D internal RC clock
- 0 = Clock derived from system clock

bit 14-13    **Reserved:** Maintain as '0'

bit 12-8    **SAMC[4:0]:** Auto-Sample Time bits

- 11111 = 31 TAD
- ...
- 00001 = 1 TAD
- 00000 = 0 TAD (not recommended)

bit 7-0      **ADCS[7:0]:** A/D Conversion Clock Select bits

- 11111111
- ... = Reserved, do not use
- 01000000
- 00111111 = 64 Tcy
- 00111110 = 63 Tcy
- ...
- 00000001 = 2 \* Tcy
- 00000000 = Tcy

# PIC24FJ256GA110 FAMILY

## REGISTER 21-4: AD1CHS: A/D INPUT SELECT REGISTER

R/W-0	U-0	U-0	R/W-0	R/W-0	R/W-0	R/W-0	R/W-0
CH0NB	—	—	CH0SB[4:0] <sup>(1)</sup>				
bit 15							bit 8

R/W-0	U-0	U-0	R/W-0	R/W-0	R/W-0	R/W-0	R/W-0
CH0NA	—	—	CH0SA[4:0]				
bit 7							bit 0

### Legend:

R = Readable bit                      W = Writable bit                      U = Unimplemented bit, read as '0'  
 -n = Value at POR                      '1' = Bit is set                      '0' = Bit is cleared                      x = Bit is unknown

- bit 15            **CH0NB:** Channel 0 Negative Input Select for MUX B Multiplexer Setting bit  
                   1 = Channel 0 negative input is AN1  
                   0 = Channel 0 negative input is VR-
- bit 14-13       **Unimplemented:** Read as '0'
- bit 12-8        **CH0SB[4:0]:** Channel 0 Positive Input Select for MUX B Multiplexer Setting bits<sup>(1)</sup>  
                   10001 = Channel 0 positive input is internal band gap reference (VBG)  
                   10000 = Channel 0 positive input is VBG/2  
                   01111 = Channel 0 positive input is AN15  
                   01110 = Channel 0 positive input is AN14  
                   01101 = Channel 0 positive input is AN13  
                   01100 = Channel 0 positive input is AN12  
                   01011 = Channel 0 positive input is AN11  
                   01010 = Channel 0 positive input is AN10  
                   01001 = Channel 0 positive input is AN9  
                   01000 = Channel 0 positive input is AN8  
                   00111 = Channel 0 positive input is AN7  
                   00110 = Channel 0 positive input is AN6  
                   00101 = Channel 0 positive input is AN5  
                   00100 = Channel 0 positive input is AN4  
                   00011 = Channel 0 positive input is AN3  
                   00010 = Channel 0 positive input is AN2  
                   00001 = Channel 0 positive input is AN1  
                   00000 = Channel 0 positive input is AN0
- bit 7            **CH0NA:** Channel 0 Negative Input Select for MUX A Multiplexer Setting bit  
                   1 = Channel 0 negative input is AN1  
                   0 = Channel 0 negative input is VR-
- bit 6-5        **Unimplemented:** Read as '0'
- bit 4-0        **CH0SA[4:0]:** Channel 0 Positive Input Select for MUX A Multiplexer Setting bits  
                   Implemented combinations are identical to those for CH0SB[4:0] (above).

**Note 1:** Combinations, '10010' through '11111', are unimplemented; do not use.

# PIC24FJ256GA110 FAMILY

## REGISTER 21-5: AD1PCFGL: A/D PORT CONFIGURATION REGISTER (LOW)

R/W-0	R/W-0	R/W-0	R/W-0	R/W-0	R/W-0	R/W-0	R/W-0
PCFG[15:8]							
bit 15							
bit 8							

R/W-0	R/W-0	R/W-0	R/W-0	R/W-0	R/W-0	R/W-0	R/W-0
PCFG[7:0]							
bit 7							
bit 0							

### Legend:

R = Readable bit                      W = Writable bit                      U = Unimplemented bit, read as '0'  
 -n = Value at POR                      '1' = Bit is set                      '0' = Bit is cleared                      x = Bit is unknown

bit 15-0      **PCFG[15:0]:** Analog Input Pin Configuration Control bits  
 1 = Pin for corresponding analog channel is configured in Digital mode; I/O port read enabled  
 0 = Pin configured in Analog mode; I/O port read disabled, A/D samples pin voltage

## REGISTER 21-6: AD1PCFGH: A/D PORT CONFIGURATION REGISTER (HIGH)

U-0	U-0	U-0	U-0	U-0	U-0	U-0	U-0
—	—	—	—	—	—	—	—
bit 15							
bit 8							

U-0	U-0	U-0	U-0	U-0	U-0	R/W-0	R/W-0
—	—	—	—	—	—	PCFG17	PCFG16
bit 7							
bit 0							

### Legend:

R = Readable bit                      W = Writable bit                      U = Unimplemented bit, read as '0'  
 -n = Value at POR                      '1' = Bit is set                      '0' = Bit is cleared                      x = Bit is unknown

bit 15-2      **Unimplemented:** Read as '0'  
 bit 1      **PCFG17:** A/D Input Band Gap Scan Enable bit  
             1 = Analog channel disabled from input scan  
             0 = Internal band gap (V<sub>BG</sub>) channel enabled for input scan  
 bit 0      **PCFG16:** A/D Input Half Band Gap Scan Enable bit  
             1 = Analog channel disabled from input scan  
             0 = Internal V<sub>BG</sub>/2 channel enabled for input scan

# PIC24FJ256GA110 FAMILY

## REGISTER 21-7: AD1CSSL: A/D INPUT SCAN SELECT REGISTER (LOW)

R/W-0	R/W-0	R/W-0	R/W-0	R/W-0	R/W-0	R/W-0	R/W-0
CSSL[15:8]							
bit 15							bit 8

R/W-0	R/W-0	R/W-0	R/W-0	R/W-0	R/W-0	R/W-0	R/W-0
CSSL[7:0]							
bit 7							bit 0

### Legend:

R = Readable bit	W = Writable bit	U = Unimplemented bit, read as '0'
-n = Value at POR	'1' = Bit is set	'0' = Bit is cleared      x = Bit is unknown

bit 15-0      **CSSL[15:0]:** A/D Input Pin Scan Selection bits  
 1 = Corresponding analog channel selected for input scan  
 0 = Analog channel omitted from input scan

# PIC24FJ256GA110 FAMILY

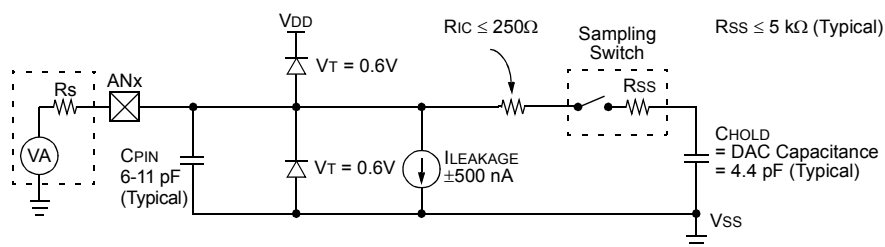
**EQUATION 21-1: A/D CONVERSION CLOCK PERIOD<sup>(1)</sup>**

$$T_{AD} = T_{CY} \cdot (ADCS_x + 1)$$

$$ADCS_x = \frac{T_{AD}}{T_{CY}} - 1$$

**Note 1:** Based on  $T_{CY} = 2 * T_{OSC}$ ; Doze mode and PLL are disabled.

**FIGURE 21-2: 10-BIT A/D CONVERTER ANALOG INPUT MODEL**

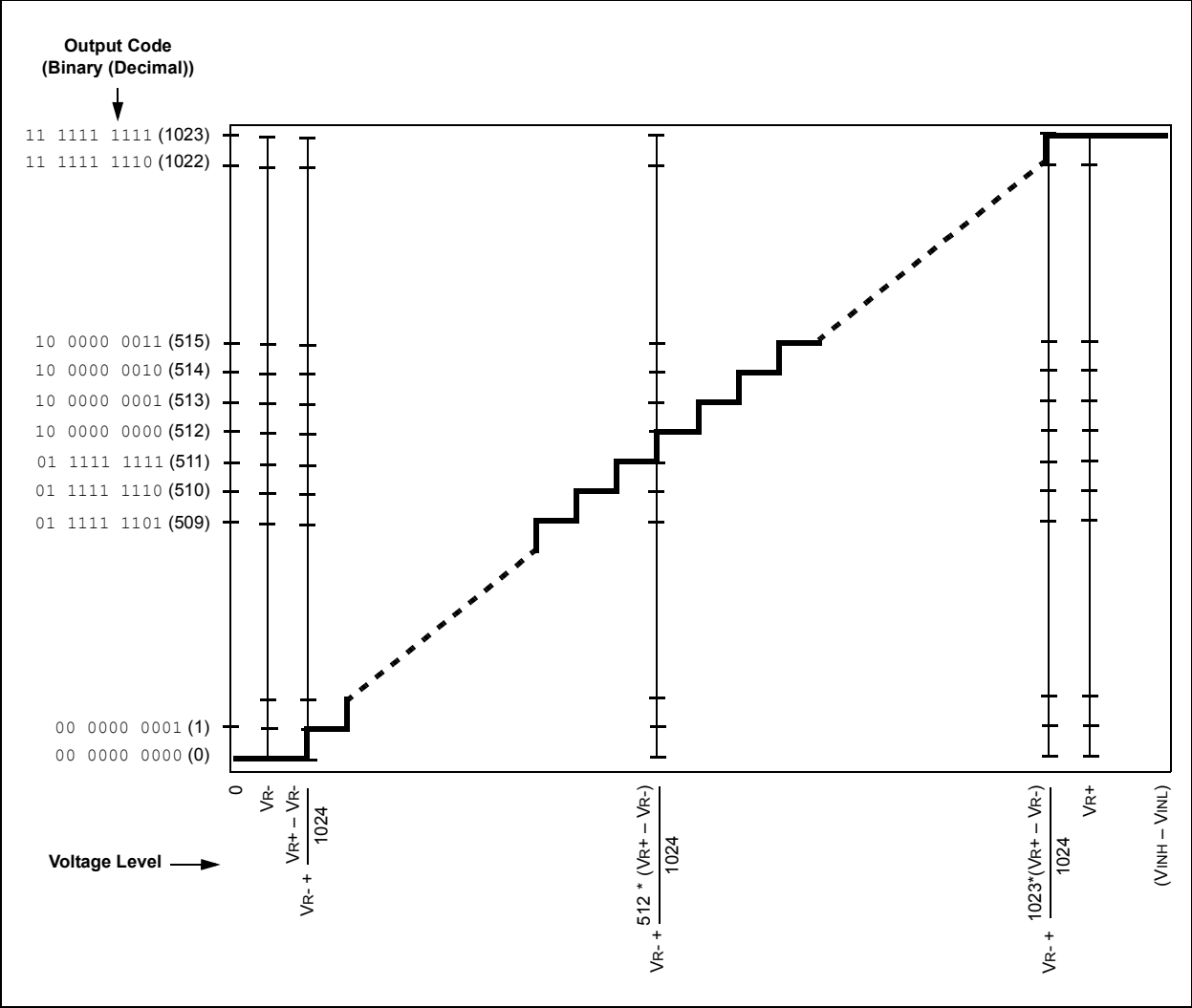


Legend:	
CPIN	= Input Capacitance
VT	= Threshold Voltage
ILEAKAGE	= Leakage Current at the pin due to various junctions
RIC	= Interconnect Resistance
RSS	= Sampling Switch Resistance
CHOLD	= Sample/Hold Capacitance (from DAC)

**Note:** CPIN value depends on device package and is not tested. The effect of CPIN is negligible if  $R_s \leq 5 \text{ k}\Omega$ .

# PIC24FJ256GA110 FAMILY

FIGURE 21-3: A/D TRANSFER FUNCTION



## 22.0 TRIPLE COMPARATOR MODULE

**Note:** This data sheet summarizes the features of this group of PIC24F devices. It is not intended to be a comprehensive reference source. For more information, refer to “**Scalable Comparator Module**” ([www.microchip.com/DS39734](http://www.microchip.com/DS39734)) in the “*dsPIC33/PIC24 Family Reference Manual*”. The information in this data sheet supersedes the information in the FRM.

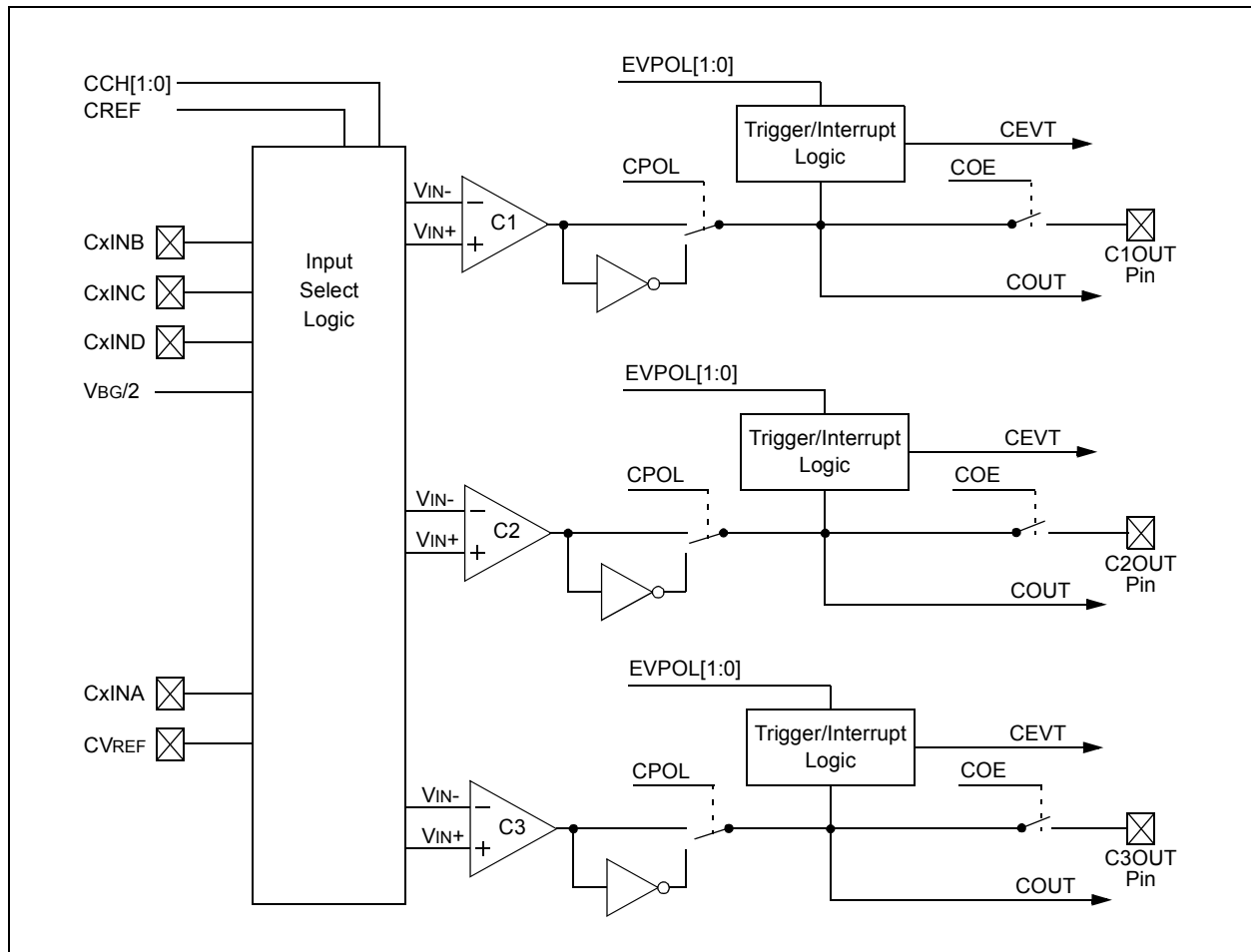
The triple comparator module provides three dual input comparators. The inputs to the comparator can be configured to use any one of four external analog inputs, as well as a voltage reference input from either the internal band gap reference divided by two ( $V_{BG}/2$ ) or the comparator voltage reference generator.

The comparator outputs may be directly connected to the CxOUT pins. When the respective COE equals ‘1’, the I/O pad logic makes the unsynchronized output of the comparator available on the pin.

A simplified block diagram of the module is shown in [Figure 22-1](#). Diagrams of the possible individual comparator configurations are shown in [Figure 22-2](#).

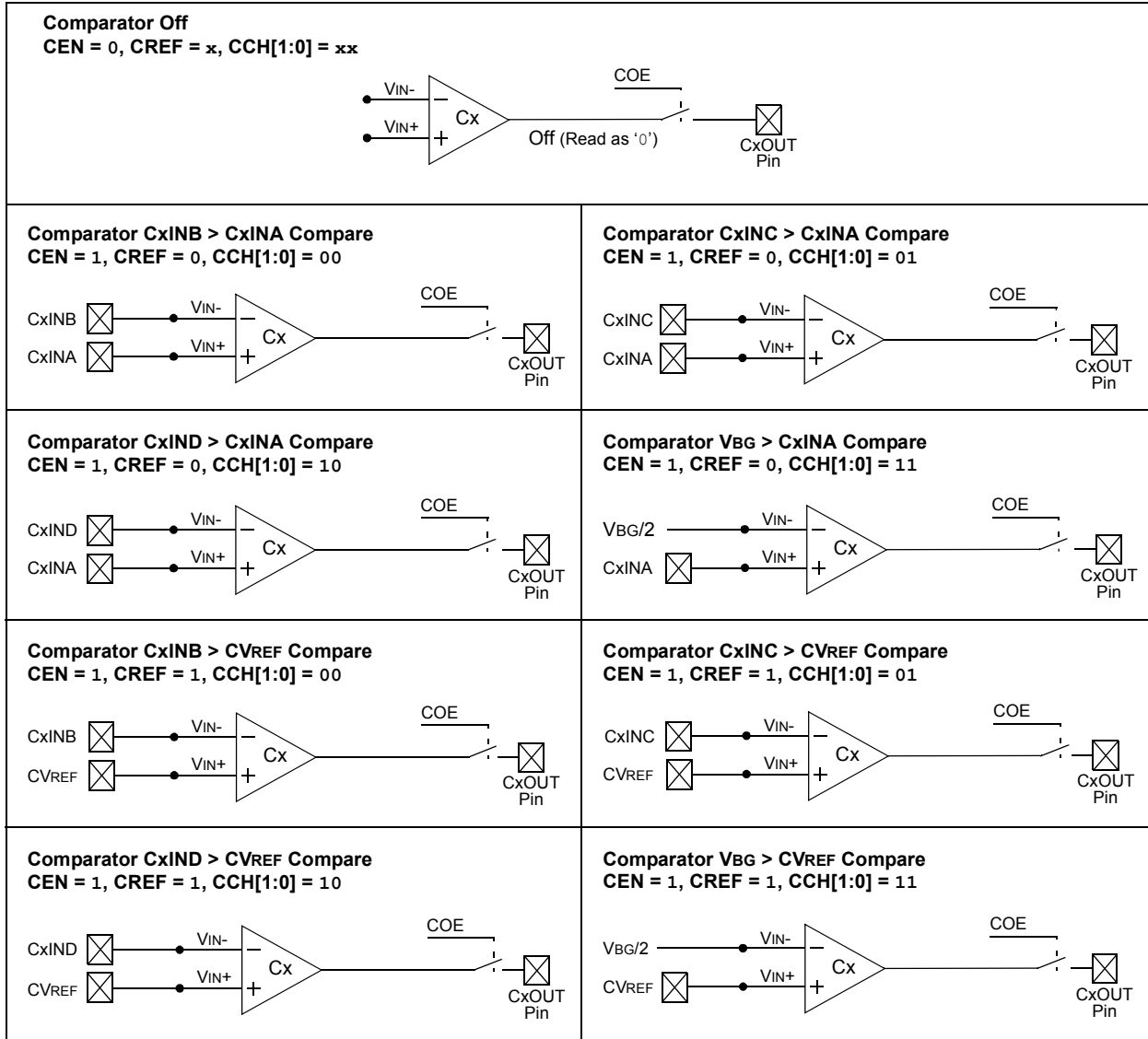
Each comparator has its own control register, CMxCON ([Register 22-1](#)), for enabling and configuring its operation. The output and event status of all three comparators are provided in the CMSTAT register ([Register 22-2](#)).

**FIGURE 22-1: TRIPLE COMPARATOR MODULE BLOCK DIAGRAM**



# PIC24FJ256GA110 FAMILY

**FIGURE 22-2: INDIVIDUAL COMPARATOR CONFIGURATIONS**



# PIC24FJ256GA110 FAMILY

## REGISTER 22-1: CMxCON: COMPARATOR x CONTROL REGISTERS (COMPARATORS 1 THROUGH 3)

R/W-0	R/W-0	R/W-0	U-0	U-0	U-0	R/W-0	R-0
CEN	COE	CPOL	—	—	—	CEVT	COUT
bit 15							bit 8

R/W-0	R/W-0	U-0	R/W-0	U-0	U-0	R/W-0	R/W-0
EVPOL1	EVPOL0	—	CREF	—	—	CCH1	CCH0
bit 7							bit 0

### Legend:

R = Readable bit	W = Writable bit	U = Unimplemented bit, read as '0'
-n = Value at POR	'1' = Bit is set	'0' = Bit is cleared
		x = Bit is unknown

- bit 15     **CEN:** Comparator Enable bit  
           1 = Comparator is enabled  
           0 = Comparator is disabled
- bit 14     **COE:** Comparator Output Enable bit  
           1 = Comparator output is present on the CxOUT pin.  
           0 = Comparator output is internal only
- bit 13     **CPOL:** Comparator Output Polarity Select bit  
           1 = Comparator output is inverted  
           0 = Comparator output is not inverted
- bit 12-10   **Unimplemented:** Read as '0'
- bit 9       **CEVT:** Comparator Event bit  
           1 = Comparator event defined by EVPOL[1:0] has occurred; subsequent triggers and interrupts are disabled until the bit is cleared  
           0 = Comparator event has not occurred
- bit 8       **COUT:** Comparator Output bit  
           When CPOL = 0:  
           1 =  $V_{IN+} > V_{IN-}$   
           0 =  $V_{IN+} < V_{IN-}$   
           When CPOL = 1:  
           1 =  $V_{IN+} < V_{IN-}$   
           0 =  $V_{IN+} > V_{IN-}$
- bit 7-6     **EVPOL[1:0]:** Trigger/Event/Interrupt Polarity Select bits  
           11 = Trigger/event/interrupt generated on any change of the comparator output  
           10 = Trigger/event/interrupt generated on transition of the comparator output:  
               High-to-low transition only.  
           01 = Trigger/event/interrupt generated on transition of the comparator output:  
               Low-to-high transition only.  
           00 = Trigger/event/interrupt generation is disabled
- bit 5       **Unimplemented:** Read as '0'
- bit 4       **CREF:** Comparator Reference Select bits (noninverting input)  
           1 = Noninverting input connects to internal CVREF voltage  
           0 = Noninverting input connects to CxINA pin
- bit 3-2     **Unimplemented:** Read as '0'

# PIC24FJ256GA110 FAMILY

## REGISTER 22-1: CMxCON: COMPARATOR x CONTROL REGISTERS (COMPARATORS 1 THROUGH 3) (CONTINUED)

bit 1-0      **CCH[1:0]:** Comparator Channel Select bits  
 11 = Inverting input of comparator connects to VBG/2  
 10 = Inverting input of comparator connects to CxIND pin  
 01 = Inverting input of comparator connects to CxINC pin  
 00 = Inverting input of comparator connects to CxINB pin

## REGISTER 22-2: CMSTAT: COMPARATOR MODULE STATUS REGISTER

R/W-0	U-0	U-0	U-0	U-0	R-0	R-0	R-0
CMIDL	—	—	—	—	C3EVT	C2EVT	C1EVT
bit 15						bit 8	

U-0	U-0	U-0	U-0	U-0	R-0	R-0	R-0
—	—	—	—	—	C3OUT	C2OUT	C1OUT
bit 7						bit 0	

### Legend:

R = Readable bit      W = Writable bit      U = Unimplemented bit, read as '0'  
 -n = Value at POR      '1' = Bit is set      '0' = Bit is cleared      x = Bit is unknown

bit 15      **CMIDL:** Comparator Stop in Idle Mode bit  
 1 = Module does not generate interrupts in Idle mode, but is otherwise operational  
 0 = Module continues normal operation in Idle mode

bit 14-11      **Unimplemented:** Read as '0'

bit 10      **C3EVT:** Comparator 3 Event Status bit (read-only)  
 Shows the current event status of Comparator 3 (CM3CON[9]).

bit 9      **C2EVT:** Comparator 2 Event Status bit (read-only)  
 Shows the current event status of Comparator 2 (CM2CON[9]).

bit 8      **C1EVT:** Comparator 1 Event Status bit (read-only)  
 Shows the current event status of Comparator 1 (CM1CON[9]).

bit 7-3      **Unimplemented:** Read as '0'

bit 2      **C3OUT:** Comparator 3 Output Status bit (read-only)  
 Shows the current output of Comparator 3 (CM3CON[8]).

bit 1      **C2OUT:** Comparator 2 Output Status bit (read-only)  
 Shows the current output of Comparator 2 (CM2CON[8]).

bit 0      **C1OUT:** Comparator 1 Output Status bit (read-only)  
 Shows the current output of Comparator 1 (CM1CON[8]).

# PIC24FJ256GA110 FAMILY

## 23.0 COMPARATOR VOLTAGE REFERENCE

**Note:** This data sheet summarizes the features of this group of PIC24F devices. It is not intended to be a comprehensive reference source. For more information, refer to “**Comparator Voltage Reference Module**” ([www.microchip.com/DS39709](http://www.microchip.com/DS39709)) in the “*dsPIC33/PIC24 Family Reference Manual*”. The information in this data sheet supersedes the information in the FRM.

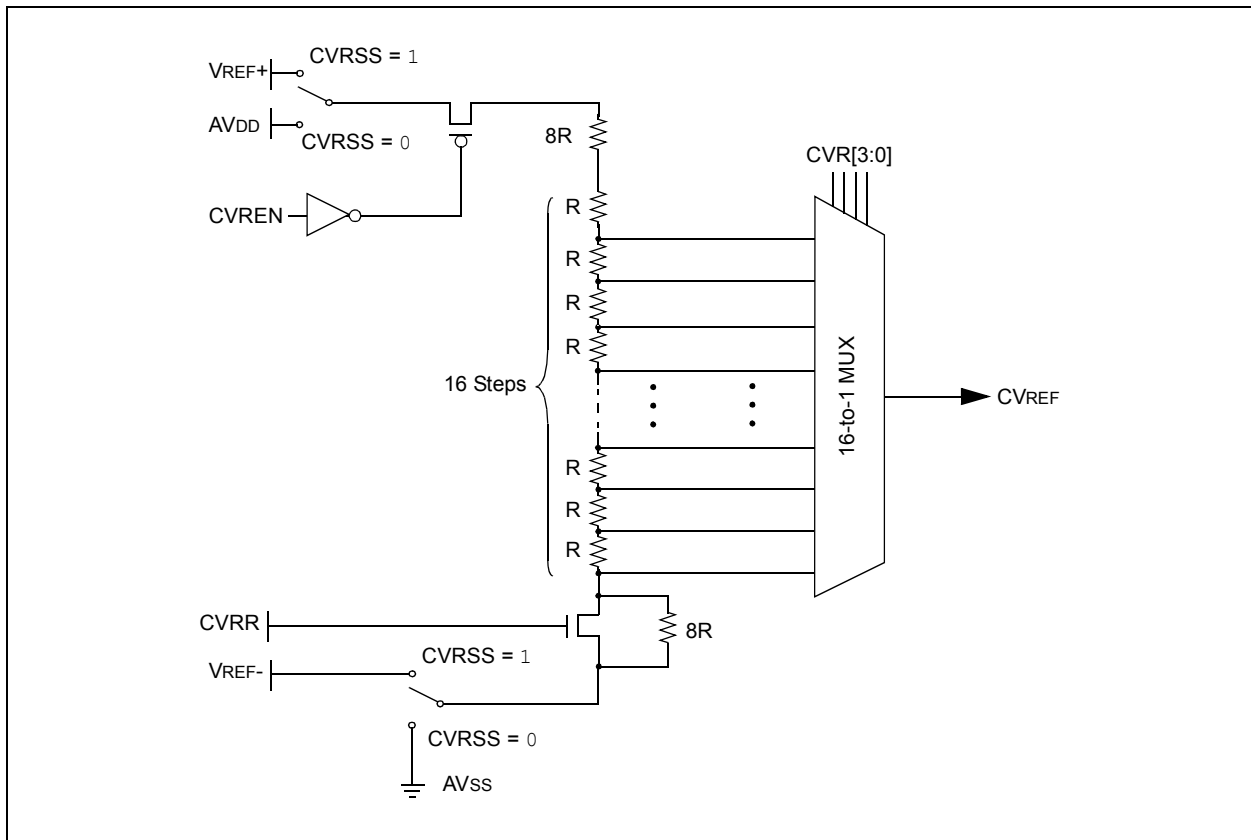
## 23.1 Configuring the Comparator Voltage Reference

The voltage reference module is controlled through the CVRCON register ([Register 23-1](#)). The comparator voltage reference provides two ranges of output voltage, each with 16 distinct levels. The range to be used is selected by the CVRR bit (CVRCON[5]). The primary difference between the ranges is the size of the steps selected by the CVREF Selection bits (CVR[3:0]), with one range offering finer resolution.

The comparator reference supply voltage can come from either  $V_{DD}$  and  $V_{SS}$ , or the external  $V_{REF+}$  and  $V_{REF-}$ . The voltage source is selected by the CVRSS bit (CVRCON[4]).

The settling time of the comparator voltage reference must be considered when changing the CVREF output.

FIGURE 23-1: COMPARATOR VOLTAGE REFERENCE BLOCK DIAGRAM



# PIC24FJ256GA110 FAMILY

## REGISTER 23-1: CVRCON: COMPARATOR VOLTAGE REFERENCE CONTROL REGISTER

U-0	U-0	U-0	U-0	U-0	U-0	U-0	U-0
—	—	—	—	—	—	—	—
bit 15							bit 8

R/W-0	R/W-0	R/W-0	R/W-0	R/W-0	R/W-0	R/W-0	R/W-0
CVREN	CVROE	CVRR	CVRSS	CVR3	CVR2	CVR1	CVR0
bit 7							bit 0

### Legend:

R = Readable bit

W = Writable bit

U = Unimplemented bit, read as '0'

-n = Value at POR

'1' = Bit is set

'0' = Bit is cleared

x = Bit is unknown

bit 15-8 **Unimplemented:** Read as '0'

bit 7 **CVREN:** Comparator Voltage Reference Enable bit

1 = CVREF circuit powered on

0 = CVREF circuit powered down

bit 6 **CVROE:** Comparator VREF Output Enable bit

1 = CVREF voltage level is output on the CVREF pin

0 = CVREF voltage level is disconnected from the CVREF pin

bit 5 **CVRR:** Comparator VREF Range Selection bit

1 = CVRSRC range should be 0 to 0.625 CVRSRC with CVRSRC/24 step-size

0 = CVRSRC range should be 0.25 to 0.719 CVRSRC with CVRSRC/32 step-size

bit 4 **CVRSS:** Comparator VREF Source Selection bit

1 = Comparator reference source, CVRSRC = VREF+ – VREF-

0 = Comparator reference source, CVRSRC = AVDD – AVSS

bit 3-0 **CVR[3:0]:** Comparator VREF Value Selection,  $0 \leq \text{CVR}[3:0] \leq 15$ , bits

When CVRR = 1:

$$\text{CVREF} = (\text{CVR}[3:0] / 24) \cdot (\text{CVRSRC})$$

When CVRR = 0:

$$\text{CVREF} = 1/4 \cdot (\text{CVRSRC}) + (\text{CVR}[3:0] / 32) \cdot (\text{CVRSRC})$$

## 24.0 CHARGE TIME MEASUREMENT UNIT (CTMU)

**Note:** This data sheet summarizes the features of this group of PIC24F devices. It is not intended to be a comprehensive reference source. For more information, refer to “Charge Time Measurement Unit (CTMU)” ([www.microchip.com/DS39724](http://www.microchip.com/DS39724)) in the “dsPIC33/PIC24 Family Reference Manual”. The information in this data sheet supersedes the information in the FRM.

The Charge Time Measurement Unit is a flexible analog module that provides accurate differential time measurement between pulse sources, as well as asynchronous pulse generation. Its key features include:

- Four Edge Input Trigger Sources
- Polarity Control for Each Edge Source
- Control of Edge Sequence
- Control of Response to Edges
- Time Measurement Resolution of 1 Nanosecond
- Accurate Current Source Suitable for Capacitive Measurement

Together with other on-chip analog modules, the CTMU can be used to precisely measure time, measure capacitance, measure relative changes in capacitance or generate output pulses that are independent of the system clock. The CTMU module is ideal for interfacing with capacitive-based sensors.

The CTMU is controlled through two registers: CTMUCON and CTMUICON. CTMUCON enables the module and controls edge source selection, edge

source polarity selection, and edge sequencing. The CTMUICON register controls the selection and trim of the current source.

### 24.1 Measuring Capacitance

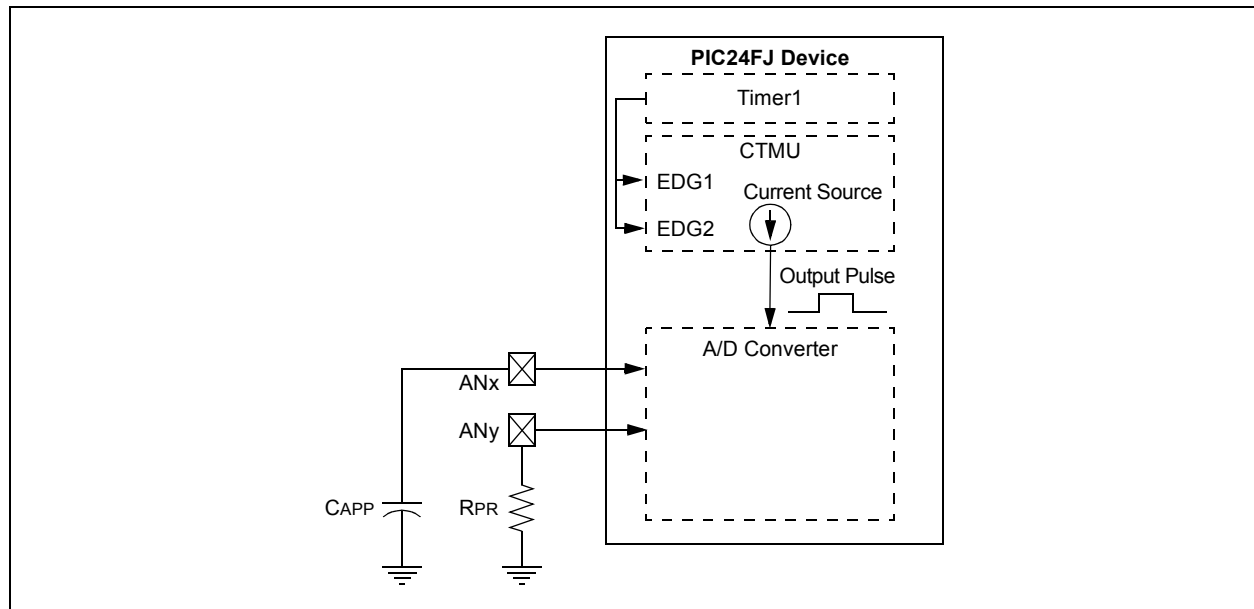
The CTMU module measures capacitance by generating an output pulse, with a width equal to the time, between edge events on two separate input channels. The pulse edge events to both input channels can be selected from four sources: two internal peripheral modules (OC1 and Timer1) and two external pins (CTEDG1 and CTEDG2). This pulse is used with the module’s precision current source to calculate capacitance according to the relationship

$$I = C \cdot \frac{dV}{dT}$$

For capacitance measurements, the A/D Converter samples an external capacitor (CAPP) on one of its input channels after the CTMU output’s pulse. A Precision Resistor (RPR) provides current source calibration on a second A/D channel. After the pulse ends, the converter determines the voltage on the capacitor. The actual calculation of capacitance is performed in software by the application.

Figure 24-1 shows the external connections used for capacitance measurements, and how the CTMU and A/D modules are related in this application. This example also shows the edge events coming from Timer1, but other configurations using external edge sources are possible. A detailed discussion on measuring capacitance and time with the CTMU module is provided in the “dsPIC33/PIC24 Family Reference Manual”.

**FIGURE 24-1: TYPICAL CONNECTIONS AND INTERNAL CONFIGURATION FOR CAPACITANCE MEASUREMENT**



# PIC24FJ256GA110 FAMILY

## 24.2 Measuring Time

Time measurements on the pulse width can be similarly performed using the A/D module's internal capacitor (CAD) and a precision resistor for current calibration. Figure 24-2 shows the external connections used for time measurements, and how the CTMU and A/D modules are related in this application. This example also shows both edge events coming from the external CTEDG pins, but other configurations using internal edge sources are possible. A detailed discussion on measuring capacitance and time with the CTMU module is provided in the "dsPIC33/PIC24 Family Reference Manual".

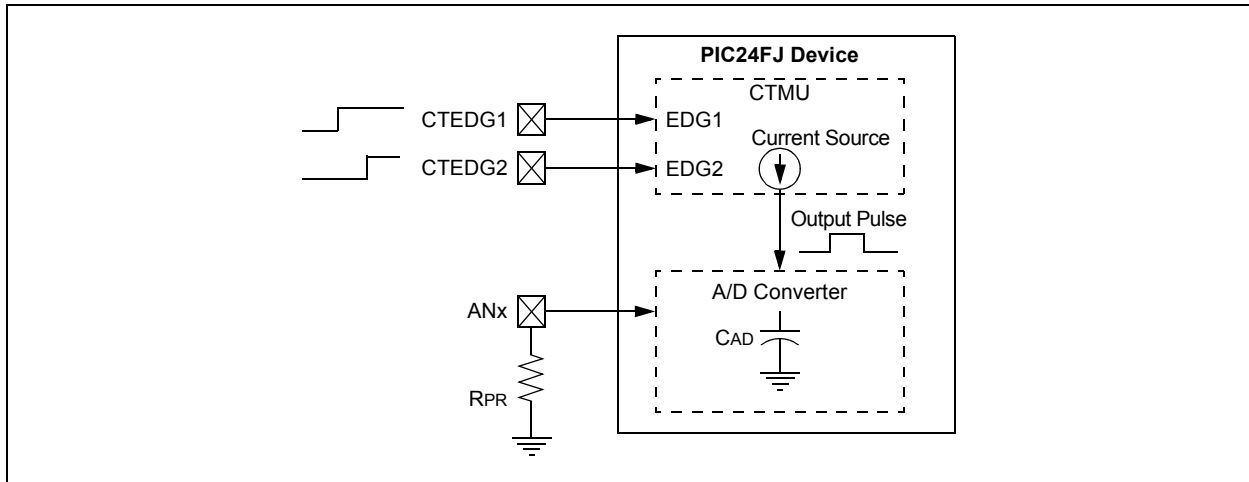
## 24.3 Pulse Generation and Delay

The CTMU module can also generate an output pulse with edges that are not synchronous with the device's system clock. More specifically, it can generate a pulse with a programmable delay from an edge event input to the module.

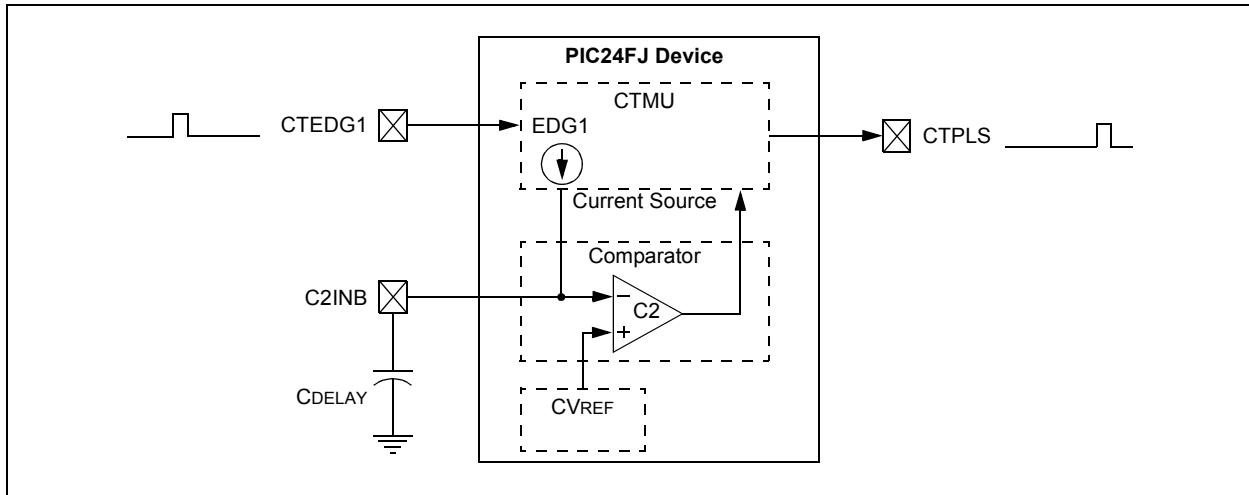
When the module is configured for pulse generation delay by setting the TGEN bit (CTMUCON[12]), the internal current source is connected to the B input of Comparator 2. A capacitor (CDELAY) is connected to the Comparator 2 pin, C2INB, and the comparator voltage reference, CVREF, is connected to C2INA. CVREF is then configured for a specific trip point. The module begins to charge CDELAY when an edge event is detected. When CDELAY charges above the CVREF trip point, a pulse is output on CTPLS. The length of the pulse delay is determined by the value of CDELAY and the CVREF trip point.

Figure 24-3 shows the external connections for pulse generation, as well as the relationship of the different analog modules required. While CTEDG1 is shown as the input pulse source, other options are available. A detailed discussion on pulse generation with the CTMU module is provided in the "dsPIC33/PIC24 Family Reference Manual".

**FIGURE 24-2: TYPICAL CONNECTIONS AND INTERNAL CONFIGURATION FOR TIME MEASUREMENT**



**FIGURE 24-3: TYPICAL CONNECTIONS AND INTERNAL CONFIGURATION FOR PULSE DELAY GENERATION**



# PIC24FJ256GA110 FAMILY

## REGISTER 24-1: CTMUCON: CTMU CONTROL REGISTER

R/W-0	U-0	R/W-0	R/W-0	R/W-0	R/W-0	R/W-0	R/W-0
CTMUEN	—	CTMUSIDL	TGEN <sup>(1)</sup>	EDGEN	EDGSEQEN	IDISSEN	CTTRIG
bit 15							bit 8

R/W-0	R/W-0	R/W-0	R/W-0	R/W-0	R/W-0	R/W-0	R/W-0
EDG2POL	EDG2SEL1	EDG2SEL0	EDG1POL	EDG1SEL1	EDG1SEL0	EDG2STAT	EDG1STAT
bit 7							bit 0

### Legend:

R = Readable bit                      W = Writable bit                      U = Unimplemented bit, read as '0'  
 -n = Value at POR                      '1' = Bit is set                      '0' = Bit is cleared                      x = Bit is unknown

- bit 15        **CTMUEN:** CTMU Enable bit  
                  1 = Module is enabled  
                  0 = Module is disabled
- bit 14        **Unimplemented:** Read as '0'
- bit 13        **CTMUSIDL:** Stop in Idle Mode bit  
                  1 = Discontinues module operation when device enters Idle mode  
                  0 = Continues module operation in Idle mode
- bit 12        **TGEN:** Time Generation Enable bit<sup>(1)</sup>  
                  1 = Enables edge delay generation  
                  0 = Disables edge delay generation
- bit 11        **EDGEN:** Edge Enable bit  
                  1 = Edges are not blocked  
                  0 = Edges are blocked
- bit 10        **EDGSEQEN:** Edge Sequence Enable bit  
                  1 = Edge 1 event must occur before Edge 2 event can occur  
                  0 = No edge sequence is needed
- bit 9         **IDISSEN:** Analog Current Source Control bit  
                  1 = Analog current source output is grounded  
                  0 = Analog current source output is not grounded
- bit 8         **CTTRIG:** Trigger Control bit  
                  1 = Trigger output is enabled  
                  0 = Trigger output is disabled
- bit 7         **EDG2POL:** Edge 2 Polarity Select bit  
                  1 = Edge 2 programmed for a positive edge response  
                  0 = Edge 2 programmed for a negative edge response
- bit 6-5       **EDG2SEL[1:0]:** Edge 2 Source Select bits  
                  11 = CTED1 pin  
                  10 = CTED2 pin  
                  01 = OC1 module  
                  00 = Timer1 module
- bit 4         **EDG1POL:** Edge 1 Polarity Select bit  
                  1 = Edge 1 programmed for a positive edge response  
                  0 = Edge 1 programmed for a negative edge response

**Note 1:** If TGEN = 1, the CTEDGx inputs and CTPLS outputs must be assigned to available RPN pins before use. See [Section 10.4 "Peripheral Pin Select \(PPS\)"](#) for more information.

# PIC24FJ256GA110 FAMILY

## REGISTER 24-1: CTMUCON: CTMU CONTROL REGISTER (CONTINUED)

bit 3-2 **EDG1SEL[1:0]:** Edge 1 Source Select bits

11 = CTED1 pin  
 10 = CTED2 pin  
 01 = OC1 module  
 00 = Timer1 module

bit 1 **EDG2STAT:** Edge 2 Status bit

1 = Edge 2 event has occurred  
 0 = Edge 2 event has not occurred

bit 0 **EDG1STAT:** Edge 1 Status bit

1 = Edge 1 event has occurred  
 0 = Edge 1 event has not occurred

**Note 1:** If TGEN = 1, the CTEDGx inputs and CTPLS outputs must be assigned to available RPn pins before use. See [Section 10.4 “Peripheral Pin Select \(PPS\)”](#) for more information.

## REGISTER 24-2: CTMUICON: CTMU CURRENT CONTROL REGISTER

R/W-0	R/W-0	R/W-0	R/W-0	R/W-0	R/W-0	R/W-0	R/W-0
ITRIM[5:0]						IRNG[1:0]	
bit 15						bit 8	

U-0	U-0	U-0	U-0	U-0	U-0	U-0	U-0
—	—	—	—	—	—	—	—
bit 7						bit 0	

### Legend:

R = Readable bit	W = Writable bit	U = Unimplemented bit, read as '0'
-n = Value at POR	'1' = Bit is set	'0' = Bit is cleared
		x = Bit is unknown

bit 15-10 **ITRIM[5:0]:** Current Source Trim bits

011111 = Maximum positive change from nominal current  
 011110  
 ...  
 000001 = Minimum positive change from nominal current  
 000000 = Nominal current output specified by IRNG[1:0]  
 111111 = Minimum negative change from nominal current  
 ...  
 100010  
 100001 = Maximum negative change from nominal current

bit 9-8 **IRNG[1:0]:** Current Source Range Select bits

11 = 100 × Base Current  
 10 = 10 × Base Current  
 01 = Base current level (0.55 μA nominal)  
 00 = Current source disabled

bit 7-0 **Unimplemented:** Read as '0'

# PIC24FJ256GA110 FAMILY

## 25.0 SPECIAL FEATURES

**Note:** This data sheet summarizes the features of this group of PIC24F devices. It is not intended to be a comprehensive reference source. For more information, refer to the following sections of the “*dsPIC33/PIC24 Family Reference Manual*”:

- “**Watchdog Timer (WDT)**”  
([www.microchip.com/DS39697](http://www.microchip.com/DS39697))
- “**High-Level Device Integration**”  
([www.microchip.com/DS39719](http://www.microchip.com/DS39719))
- “**Programming and Diagnostics**”  
([www.microchip.com/DS39716](http://www.microchip.com/DS39716))

PIC24FJ256GA110 family devices include several features intended to maximize application flexibility and reliability, and minimize cost through elimination of external components. These are:

- Flexible Configuration
- Watchdog Timer (WDT)
- Code Protection
- JTAG Boundary Scan Interface
- In-Circuit Serial Programming
- In-Circuit Emulation

### 25.1 Configuration Bits

The Configuration bits can be programmed (read as ‘0’), or left unprogrammed (read as ‘1’), to select various device configurations. These bits are mapped starting at program memory location: F80000h. A detailed explanation of the various bit functions is provided in [Register 25-1](#) through [Register 25-5](#).

Note that address F80000h is beyond the user program memory space. In fact, it belongs to the configuration memory space (800000h-FFFFFFh), which can only be accessed using table reads.

### 25.1.1 CONSIDERATIONS FOR CONFIGURING PIC24FJ256GA110 FAMILY DEVICES

In PIC24FJ256GA110 family devices, the configuration bytes are implemented as volatile memory. This means that configuration data must be programmed each time the device is powered up. Configuration data are stored in the three words at the top of the on-chip program memory space, known as the Flash Configuration Words. Their specific locations are shown in [Table 25-1](#). These are packed representations of the actual device Configuration bits, whose actual locations are distributed among several locations in configuration space. The configuration data are automatically loaded from the Flash Configuration Words to the proper Configuration registers during device Resets.

**Note:** Configuration data are reloaded on all types of device Resets.

When creating applications for these devices, users should always specifically allocate the location of the Flash Configuration Word for configuration data. This is to make certain that program code is not stored in this address when the code is compiled.

The upper byte of all Flash Configuration Words in program memory should always be ‘1111 1111’. This makes them appear to be NOP instructions in the remote event that their locations are ever executed by accident. Since Configuration bits are not implemented in the corresponding locations, writing ‘1’s to these locations has no effect on device operation.

**Note:** Performing a page erase operation on the last page of program memory clears the Flash Configuration Words, enabling code protection as a result. Therefore, users should avoid performing page erase operations on the last page of program memory.

**TABLE 25-1: FLASH CONFIGURATION WORD LOCATIONS FOR PIC24FJ256GA110 DEVICES**

Device	Configuration Word Addresses		
	1	2	3
PIC24FJ64GA1	ABFEh	ABFCh	ABFAh
PIC24FJ128GA1	157FEh	157FC	157FA
PIC24FJ192GA1	20BFEh	20BFC	20BFA
PIC24FJ256GA1	2ABFEh	2ABFC	2ABFA

# PIC24FJ256GA110 FAMILY

## REGISTER 25-1: CW1: FLASH CONFIGURATION WORD 1

r-1	r-1	r-1	r-1	r-1	r-1	r-1	r-1
—	—	—	—	—	—	—	—
bit 23							bit 16

r-x	R/PO-1	R/PO-1	R/PO-1	R/PO-1	r-1	R/PO-1	R/PO-1
—	JTAGEN	GCP	GWRP	DEBUG	—	ICS1	ICS0
bit 15							bit 8

R/PO-1	R/PO-1	R/PO-1	R/PO-1	R/PO-1	R/PO-1	R/PO-1	R/PO-1
FWDTEN	WINDIS	—	FWPSA	WDTPS3	WDTPS2	WDTPS1	WDTPS0
bit 7							bit 0

<b>Legend:</b>	r = Reserved bit	-n = Value when device is unprogrammed
R = Readable bit	PO = Program Once bit	U = Unimplemented bit, read as '0'
'1' = Bit is set	'0' = Bit is cleared	x = Bit is unknown

- bit 23-16 **Reserved:** Always maintain as '1'
- bit 15 **Reserved:** The value is unknown; program as '0'
- bit 14 **JTAGEN:** JTAG Port Enable bit
  - 1 = JTAG port is enabled
  - 0 = JTAG port is disabled
- bit 13 **GCP:** General Segment Program Memory Code Protection bit
  - 1 = Code protection is disabled
  - 0 = Code protection is enabled for the entire program memory space
- bit 12 **GWRP:** General Segment Code Flash Write Protection bit
  - 1 = Writes to program memory are allowed
  - 0 = Writes to program memory are disabled
- bit 11 **DEBUG:** Background Debugger Enable bit
  - 1 = Device resets into Operational mode
  - 0 = Device resets into Debug mode
- bit 10 **Reserved:** Always maintain as '1'
- bit 9-8 **ICS[1:0]:** Emulator Pin Placement Select bits
  - 11 = Emulator functions are shared with PGEC1/PGED1
  - 10 = Emulator functions are shared with PGEC2/PGED2
  - 01 = Emulator functions are shared with PGEC3/PGED3
  - 00 = Reserved; do not use
- bit 7 **FWDTEN:** Watchdog Timer Enable bit
  - 1 = Watchdog Timer is enabled
  - 0 = Watchdog Timer is disabled
- bit 6 **WINDIS:** Windowed Watchdog Timer Disable bit
  - 1 = Standard Watchdog Timer enabled
  - 0 = Windowed Watchdog Timer enabled; FWDTEN must be '1'
- bit 5 **Reserved**
- bit 4 **FWPSA:** WDT Prescaler Ratio Select bit
  - 1 = Prescaler ratio of 1:128
  - 0 = Prescaler ratio of 1:32

# PIC24FJ256GA110 FAMILY

---

## REGISTER 25-1: CW1: FLASH CONFIGURATION WORD 1 (CONTINUED)

bit 3-0      **WDTPS[3:0]:** Watchdog Timer Postscaler Select bits

1111 = 1:32,768

1110 = 1:16,384

1101 = 1:8,192

1100 = 1:4,096

1011 = 1:2,048

1010 = 1:1,024

1001 = 1:512

1000 = 1:256

0111 = 1:128

0110 = 1:64

0101 = 1:32

0100 = 1:16

0011 = 1:8

0010 = 1:4

0001 = 1:2

0000 = 1:1

# PIC24FJ256GA110 FAMILY

## REGISTER 25-2: CW2: FLASH CONFIGURATION WORD 2

r-1	r-1	r-1	r-1	r-1	r-1	r-1	r-1
—	—	—	—	—	—	—	—
bit 23							bit 16

R/PO-1	r-1	r-1	r-1	r-1	R/PO-1	R/PO-1	R/PO-1
IESO	—	—	—	—	FNOSC2	FNOSC1	FNOSC0
bit 15							bit 8

R/PO-1	R/PO-1	R/PO-1	R/PO-1	r-1	R/PO-1	R/PO-1	R/PO-1
FCKSM1	FCKSM0	OSCIOFCN	IOL1WAY	—	I2C2SEL <sup>(1)</sup>	POSCMD1	POSCMD0
bit 7							bit 0

<b>Legend:</b>	r = Reserved bit	-n = Value when device is unprogrammed
R = Readable bit	PO = Program Once bit	U = Unimplemented bit, read as '0'
'1' = Bit is set	'0' = Bit is cleared	x = Bit is unknown

bit 23-16 **Reserved:** Always maintain as '1'

bit 15 **IESO:** Internal External Switchover bit  
 1 = IESO mode (Two-Speed Start-up) enabled  
 0 = IESO mode (Two-Speed Start-up) disabled

bit 14-11 **Reserved:** Always maintain as '1'

bit 10-8 **FNOSC[2:0]:** Initial Oscillator Select bits  
 111 = Fast RC Oscillator with Postscaler (FRCDIV)  
 110 = Reserved  
 101 = Low-Power RC Oscillator (LPRC)  
 100 = Secondary Oscillator (SOSC)  
 011 = Primary Oscillator with PLL module (XTPLL, HSPLL, ECPLL)  
 010 = Primary Oscillator (XT, HS, EC)  
 001 = Fast RC Oscillator with Postscaler and PLL module (FRCPLL)  
 000 = Fast RC Oscillator (FRC)

bit 7-6 **FCKSM[1:0]:** Clock Switching and Fail-Safe Clock Monitor Configuration bits  
 1x = Clock switching and Fail-Safe Clock Monitor are disabled  
 01 = Clock switching is enabled, Fail-Safe Clock Monitor is disabled  
 00 = Clock switching is enabled, Fail-Safe Clock Monitor is enabled

bit 5 **OSCIOFCN:** OSCO Pin Configuration bit  
If POSCMD[1:0] = 11 or 00:  
 1 = OSCO/CLKO/RC15 functions as CLKO (Fosc/2)  
 0 = OSCO/CLKO/RC15 functions as port I/O (RC15)  
If POSCMD[1:0] = 10 or 01:  
 OSCIOFCN has no effect on OSCO/CLKO/RC15.

bit 4 **IOL1WAY:** IOLOCK One-Way Set Enable bit  
 1 = The IOLOCK bit (OSCCON[6]) can be set once, provided the unlock sequence has been completed; once set, the Peripheral Pin Select registers cannot be written to a second time  
 0 = The IOLOCK bit can be set and cleared as needed, provided the unlock sequence has been completed

bit 3 **Reserved:** Always maintain as '1'

bit 2 **I2C2SEL:** I2C2 Pin Select bit<sup>(1)</sup>  
 1 = Use SCL2/SDA2 pins for I2C2  
 0 = Use ASCL2/ASDA2 pins for I2C2

**Note 1:** Implemented in 100-pin devices only; otherwise unimplemented, read as '1'.

# PIC24FJ256GA110 FAMILY

## REGISTER 25-2: CW2: FLASH CONFIGURATION WORD 2 (CONTINUED)

bit 1-0 **POSCMD[1:0]:** Primary Oscillator Configuration bits  
 11 = Primary Oscillator disabled  
 10 = HS Oscillator mode selected  
 01 = XT Oscillator mode selected  
 00 = EC Oscillator mode selected

**Note 1:** Implemented in 100-pin devices only; otherwise unimplemented, read as '1'.

## REGISTER 25-3: CW3: FLASH CONFIGURATION WORD 3

r-1	r-1	r-1	r-1	r-1	r-1	r-1	r-1
—	—	—	—	—	—	—	—
bit 23							bit 16

R/PO-1	R/PO-1	R/PO-1	r-1	r-1	r-1	r-1	r-1
WPEND	WPCFG	WPDIS	—	—	—	—	—
bit 15							bit 8

R/PO-1	R/PO-1	R/PO-1	R/PO-1	R/PO-1	R/PO-1	R/PO-1	R/PO-1
WFPF[7:0]							
bit 7							bit 0

<b>Legend:</b>	r = Reserved bit	-n = Value when device is unprogrammed
R = Readable bit	PO = Program Once bit	U = Unimplemented bit, read as '0'
'1' = Bit is set	'0' = Bit is cleared	x = Bit is unknown

bit 23-16 **Reserved:** Always maintain as '1'

bit 15 **WPEND:** Segment Write Protection End Page Select bit  
 1 = Protected code segment upper boundary is at the last page of program memory; lower boundary is the code page specified by WFPF[7:0]  
 0 = Protected code segment lower boundary is at the bottom of program memory (000000h); upper boundary is the code page specified by WFPF[7:0]

bit 14 **WPCFG:** Configuration Word Code Page Protection Select bit  
 1 = Last page (at the top of program memory) and Flash Configuration Words are not protected if WPEND = 0  
 0 = Last page and Flash Configuration Words are code-protected if WPEND = 0

bit 13 **WPDIS:** Segment Write Protection Disable bit  
 1 = Segmented code protection disabled  
 0 = Segmented code protection enabled; protected segment defined by WPEND, WPCFG and WFPF<sub>x</sub> Configuration bits

bit 12-8 **Reserved:** Always maintain as '1'

bit 7-0 **WFPF[7:0]:** Protected Code Segment Boundary Page bits  
 Designates the 512-word program code page that is the boundary of the protected code segment, starting with Page 0 at the bottom of program memory.  
If WPEND = 1:  
 First address of designated code page is the lower boundary of the segment.  
If WPEND = 0:  
 Last address of designated code page is the upper boundary of the segment.



# PIC24FJ256GA110 FAMILY

## REGISTER 25-5: DEVREV: DEVICE REVISION REGISTER

r-0	r-0	r-1	r-1	U-0	U-0	U-0	U-0
—	—	—	—	—	—	—	—
bit 23						bit 16	

U-0	U-0	U-0	U-0	U-0	U-0	U-0	R
—	—	—	—	—	—	—	MAJRV2
bit 15							bit 8

R	R	U-0	U-0	U-0	R	R	R
MAJRV[1:0]		—	—	—	DOT[2:0]		
bit 7						bit 0	

**Legend:** R = Read-Only bit      r = Reserved bit      U = Unimplemented bit

- bit 23-22      **Reserved:** Read as '0'
- bit 21-20      **Reserved:** Read as '1'
- bit 19-9        **Unimplemented:** Read as '0'
- bit 8-6         **MAJRV[2:0]:** Major Revision Identifier bits
- bit 5-3         **Unimplemented:** Read as '0'
- bit 2-0         **DOT[2:0]:** Minor Revision Identifier bits

# PIC24FJ256GA110 FAMILY

## 25.2 On-Chip Voltage Regulator

All PIC24FJ256GA110 family devices power their core digital logic at a nominal 2.5V. This may create an issue for designs that are required to operate at a higher typical voltage, such as 3.3V. To simplify system design, all devices in the PIC24FJ256GA110 family incorporate an on-chip regulator that allows the device to run its core logic from VDD.

The regulator is controlled by the ENVREG pin. Tying VDD to the pin enables the regulator, which in turn, provides power to the core from the other VDD pins. When the regulator is enabled, a low-ESR capacitor (such as ceramic) must be connected to the VDDCORE/VCAP pin (Figure 25-1). This helps to maintain the stability of the regulator. The recommended value for the filter capacitor (CEFC) is provided in Section 28.1 “DC Characteristics”.

If ENVREG is tied to VSS, the regulator is disabled. In this case, separate power for the core logic at a nominal 2.5V must be supplied to the device on the VDDCORE/VCAP pin to run the I/O pins at higher voltage levels, typically 3.3V. Alternatively, the VDDCORE/VCAP and VDD pins can be tied together to operate at a lower nominal voltage. Refer to Figure 25-1 for possible configurations.

### 25.2.1 VOLTAGE REGULATOR TRACKING MODE AND LOW-VOLTAGE DETECTION

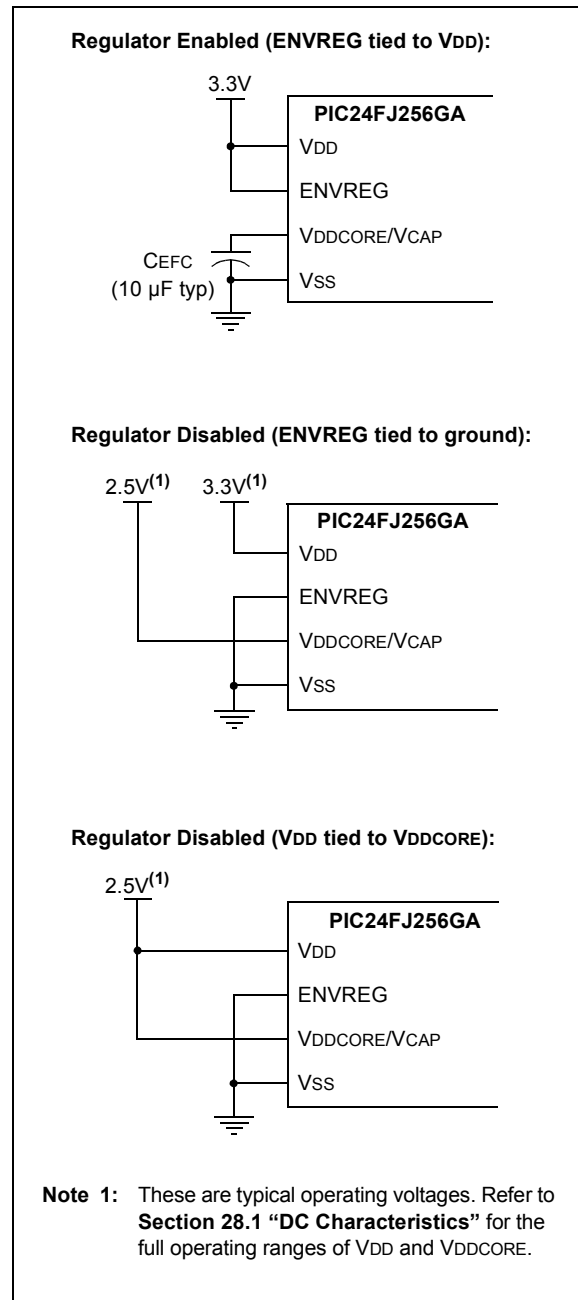
When it is enabled, the on-chip regulator provides a constant voltage of 2.5V nominal to the digital core logic.

The regulator can provide this level from a VDD of about 2.5V, all the way up to the device’s VDDMAX. It does not have the capability to boost VDD levels below 2.5V. In order to prevent “brown-out” conditions when the voltage drops too low for the regulator, the regulator enters Tracking mode. In Tracking mode, the regulator output follows VDD with a typical voltage drop of 100 mV.

When the device enters Tracking mode, it is no longer possible to operate at full speed. To provide information about when the device enters Tracking mode, the on-chip regulator includes a simple, Low-Voltage Detect circuit. When VDD drops below full-speed operating voltage, the circuit sets the Low-Voltage Detect Interrupt Flag, LVDIF (IFS4[8]). This can be used to generate an interrupt and put the application into a Low-Power Operational mode or trigger an orderly shutdown.

Low-Voltage Detection is only available when the regulator is enabled.

FIGURE 25-1: CONNECTIONS FOR THE ON-CHIP REGULATOR



# PIC24FJ256GA110 FAMILY

## 25.2.2 ON-CHIP REGULATOR AND POR

When the voltage regulator is enabled, it takes approximately 10  $\mu$ s for it to generate output. During this time, designated as TVREG, code execution is disabled. TVREG is applied every time the device resumes operation after any power-down, including Sleep mode. The length of TVREG is determined by the PMSLP bit (RCON[8]), as described in [Section 25.2.5 “Voltage Regulator Standby Mode”](#).

If the regulator is disabled, a separate Power-up Timer (PWRT) is automatically enabled. The PWRT adds a fixed delay of 64 ms nominal delay at device start-up (POR or BOR only). When waking up from Sleep with the regulator disabled, the PMSLP bit determines the wake-up time. When operating with the regulator disabled, setting PMSLP can decrease the device wake-up time.

## 25.2.3 ON-CHIP REGULATOR AND BOR

When the on-chip regulator is enabled, PIC24FJ256GA110 family devices also have a simple brown-out capability. If the voltage supplied to the regulator is inadequate to maintain the tracking level, the regulator Reset circuitry will generate a Brown-out Reset. This event is captured by the BOR flag bit (RCON[1]). The brown-out voltage specifications are provided in “Reset” ([www.microchip.com/DS39712](http://www.microchip.com/DS39712)) in the “dsPIC33/PIC24 Family Reference Manual”.

## 25.2.4 POWER-UP REQUIREMENTS

The on-chip regulator is designed to meet the power-up requirements for the device. If the application does not use the regulator, then strict power-up conditions must be adhered to. While powering up, VDDCORE must never exceed VDD by 0.3 volts.

**Note:** For more information, see [Section 28.0 “Electrical Characteristics”](#).

## 25.2.5 VOLTAGE REGULATOR STANDBY MODE

When enabled, the on-chip regulator always consumes a small incremental amount of current over IDD/IPD, including when the device is in Sleep mode, even though the core digital logic does not require power. To provide additional savings in applications where power resources are critical, the regulator automatically disables itself whenever the device goes into Sleep mode. This feature is controlled by the PMSLP bit (RCON[8]). By default, the bit is cleared, which removes power from the Flash program memory, and thus, enables Standby mode. When waking up from Standby mode, the regulator must wait for TVREG to expire before wake-up. This extra time is needed to ensure that the regulator can source enough current to power the Flash memory.

For applications which require a faster wake-up time, it is possible to disable regulator Standby mode. The PMSLP bit can be set to turn off Standby mode so that the Flash stays powered when in Sleep mode and the device can wake-up without waiting for TVREG. When PMSLP is set, the power consumption while in Sleep mode, will be approximately 40  $\mu$ A higher than power consumption when the regulator is allowed to enter Standby mode.

## 25.3 Watchdog Timer (WDT)

For PIC24FJ256GA110 family devices, the WDT is driven by the LPRC Oscillator. When the WDT is enabled, the clock source is also enabled.

The nominal WDT clock source from LPRC is 31 kHz. This feeds a prescaler that can be configured for either 5-bit (divide-by-32) or 7-bit (divide-by-128) operation. The prescaler is set by the FWPSA Configuration bit. With a 31 kHz input, the prescaler yields a nominal WDT time-out period (TWDT) of 1 ms in 5-bit mode or 4 ms in 7-bit mode.

A variable postscaler divides down the WDT prescaler output and allows for a wide range of time-out periods. The postscaler is controlled by the WDTPS[3:0] Configuration bits (CW1[3:0]), which allow the selection of a total of 16 settings, from 1:1 to 1:32,768. Using the prescaler and postscaler, time-out periods ranging from 1 ms to 131 seconds can be achieved.

The WDT, prescaler and postscaler are reset:

- On any device Reset
- On the completion of a clock switch, whether invoked by software (i.e., setting the OSWEN bit after changing the NOSCx bits) or by hardware (i.e., Fail-Safe Clock Monitor)
- When a PWRSAV instruction is executed (i.e., Sleep or Idle mode is entered)
- When the device exits Sleep or Idle mode to resume normal operation
- By a CLRWDT instruction during normal execution

If the WDT is enabled, it will continue to run during Sleep or Idle modes. When the WDT time-out occurs, the device will wake the device and code execution will continue from where the PWRSAV instruction was executed. The corresponding SLEEP or IDLE bits (RCON[3:2]) will need to be cleared in software after the device wakes up.

The WDT Flag bit, WDTO (RCON[4]), is not automatically cleared following a WDT time-out. To detect subsequent WDT events, the flag must be cleared in software.

**Note:** The CLRWDT and PWRSAV instructions clear the prescaler and postscaler counts when executed.

# PIC24FJ256GA110 FAMILY

## 25.3.1 WINDOWED OPERATION

The Watchdog Timer has an optional Fixed Window mode of operation. In this Windowed mode, `CLRWDT` instructions can only reset the WDT during the last 1/4 of the programmed WDT period. A `CLRWDT` instruction executed before that window causes a WDT Reset, similar to a WDT time-out.

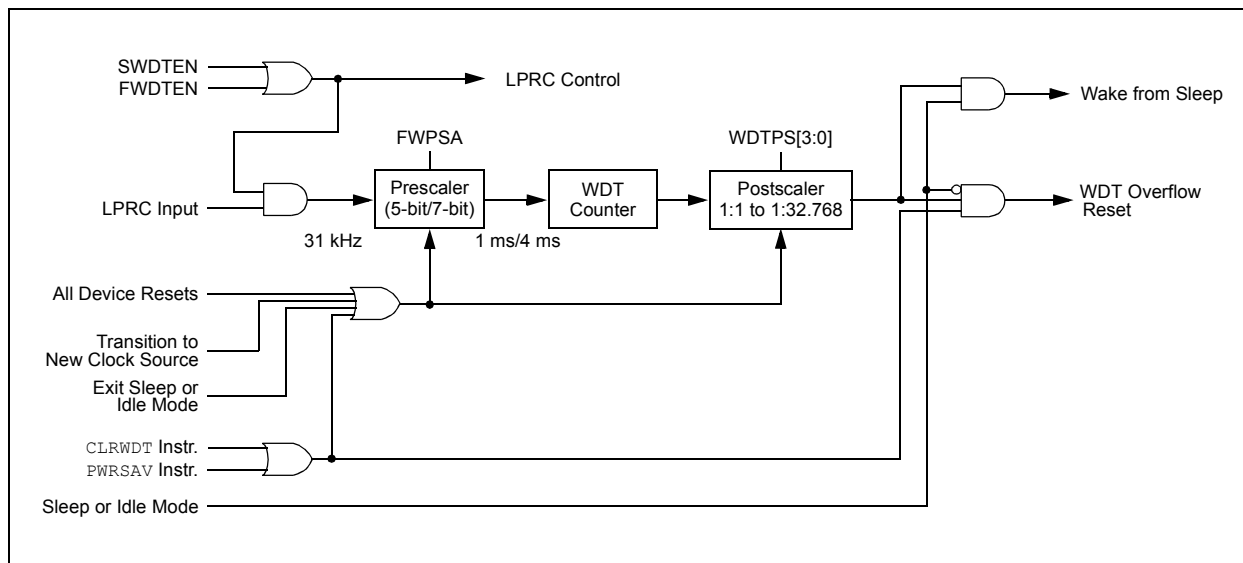
Windowed WDT mode is enabled by programming the `WINDIS` Configuration bit (`CW1[6]`) to '0'.

## 25.3.2 CONTROL REGISTER

The WDT is enabled or disabled by the `FWDTEN` Configuration bit. When the `FWDTEN` Configuration bit is set, the WDT is always enabled.

The WDT can be optionally controlled in software when the `FWDTEN` Configuration bit has been programmed to '0'. The WDT is enabled in software by setting the `SWDTEN` control bit (`RCON[5]`). The `SWDTEN` control bit is cleared on any device Reset. The software WDT option allows the user to enable the WDT for critical code segments and disable the WDT during non-critical segments for maximum power savings.

FIGURE 25-2: WDT BLOCK DIAGRAM



## 25.4 Program Verification and Code Protection

PIC24FJ256GA110 family devices provide two complimentary methods to protect application code from overwrites and erasures. These also help to protect the device from inadvertent configuration changes during run time.

### 25.4.1 GENERAL SEGMENT PROTECTION

For all devices in the PIC24FJ256GA110 family, the on-chip program memory space is treated as a single block, known as the General Segment (GS). Code

protection for this block is controlled by one Configuration bit, `GCP`. This bit inhibits external reads and writes to the program memory space. It has no direct effect in normal execution mode.

Write protection is controlled by the `GWRP` bit in the Configuration Word. When `GWRP` is programmed to '0', internal write and erase operations to program memory are blocked.

# PIC24FJ256GA110 FAMILY

## 25.4.2 CODE SEGMENT PROTECTION

In addition to global General Segment protection, a separate subrange of the program memory space can be individually protected against writes and erases. This area can be used for many purposes where a separate block of erase and write-protected code is needed, such as bootloader applications. Unlike common boot block implementations, the specially protected segment in the PIC24FJ256GA110 family devices can be located by the user anywhere in the program space and configured in a wide range of sizes.

Code segment protection provides an added level of protection to a designated area of program memory by disabling the NVM safety interlock whenever a write or erase address falls within a specified range. It does not override General Segment protection controlled by the GCP or GWRP bits. For example, if GCP and GWRP are enabled, enabling segmented code protection for the bottom half of program memory does not undo General Segment protection for the top half.

The size and type of protection for the segmented code range are configured by the WFPFx, WPEND, WPCFG and WPDIS bits in Flash Configuration Word 3. Code segment protection is enabled by programming the WPDIS bit (= 0). The WFPFx bits specify the size of the segment to be protected by specifying the 512-word code page that is the start or end of the protected segment. The specified region is inclusive, therefore, this page will also be protected.

The WPEND bit determines if the protected segment uses the top or bottom of the program space as a boundary. Programming WPEND (= 0) sets the bottom of program memory (000000h) as the lower boundary of the protected segment. Leaving WPEND

unprogrammed (= 1) protects the specified page through the last page of implemented program memory, including the Configuration Word locations.

A separate bit, WPCFG, is used to independently protect the last page of program space, including the Flash Configuration Words. If WPEND is set to protect the bottom of program memory, programming WPCFG (= 0) protects the last page. This may be useful in circumstances where write protection is needed for both a code segment in the bottom of memory, as well as the Flash Configuration Words.

The various options for segment code protection are shown in [Table 25-2](#).

## 25.4.3 CONFIGURATION REGISTER PROTECTION

The Configuration registers are protected against inadvertent or unwanted changes, or reads in two ways. The primary protection method is the same as that of the RP registers – shadow registers contain a complimentary value which is constantly compared with the actual value.

To safeguard against unpredictable events, Configuration bit changes resulting from individual cell-level disruptions (such as ESD events) will cause a parity error and trigger a device Reset.

The data for the Configuration registers are derived from the Flash Configuration Words in program memory. When the GCP bit is set, the source data for device configuration are also protected as a consequence. Even if General Segment protection is not enabled, the device configuration can be protected by using the appropriate code segment protection setting.

**TABLE 25-2: SEGMENT CODE PROTECTION CONFIGURATION OPTIONS**

Segment Configuration Bits			Write/Erase Protection of Code Segment
WPDIS	WPEND	WPCFG	
1	x	x	No additional protection enabled; all program memory protection is configured by GCP and GWRP
0	1	x	Addresses from the first address of code page, defined by WFPF[7:0], through the end of implemented program memory (inclusive) are erase/write-protected, including Flash Configuration Words
0	0	1	Address, 000000h through the last address of code page, defined by WFPF[7:0] (inclusive), is protected
0	0	0	Address, 000000h through the last address of code page, defined by WFPF[7:0] (inclusive), are erase/write-protected and the last page is also erase/write-protected

# PIC24FJ256GA110 FAMILY

---

## 25.5 JTAG Interface

PIC24FJ256GA110 family devices implement a JTAG interface, which supports boundary scan device testing.

## 25.6 In-Circuit Serial Programming™

PIC24FJ256GA110 family microcontrollers can be serially programmed while in the end application circuit. This is simply done with two lines for clock (PGECx) and data (PGEDx), and three other lines for power, ground and the programming voltage. This allows customers to manufacture boards with unprogrammed devices and then program the microcontroller just before shipping the product. This also allows the most recent firmware or a custom firmware to be programmed.

## 25.7 In-Circuit Debugger

When MPLAB® ICD 2 is selected as a debugger, the in-circuit debugging functionality is enabled. This function allows simple debugging functions when used with MPLAB IDE. Debugging functionality is controlled through the PGECx (Emulation/Debug Clock) and PGEDx (Emulation/Debug Data) pins.

To use the in-circuit debugger function of the device, the design must implement ICSP™ connections to MCLR, VDD, VSS and the PGECx/PGEDx pin pair designated by the ICSx Configuration bits. In addition, when the feature is enabled, some of the resources are not available for general use. These resources include the first 80 bytes of data RAM and two I/O pins.

## 26.0 INSTRUCTION SET SUMMARY

**Note:** This chapter is a brief summary of the PIC24F instruction set architecture, and is not intended to be a comprehensive reference source.

The PIC24F instruction set adds many enhancements to the previous PIC<sup>®</sup> MCU instruction sets, while maintaining an easy migration from previous PIC MCU instruction sets. Most instructions are a single program memory word. Only three instructions require two program memory locations.

Each single-word instruction is a 24-bit word divided into an 8-bit opcode, which specifies the instruction type and one or more operands, which further specify the operation of the instruction. The instruction set is highly orthogonal and is grouped into four basic categories:

- Word or byte-oriented operations
- Bit-oriented operations
- Literal operations
- Control operations

Table 26-1 shows the general symbols used in describing the instructions. The PIC24F instruction set summary in Table 26-2 lists all of the instructions, along with the status flags affected by each instruction.

Most word or byte-oriented W register instructions (including barrel shift instructions) have three operands:

- The first source operand, which is typically a register, 'Wb', without any address modifier
- The second source operand, which is typically a register, 'Ws', with or without an address modifier
- The destination of the result, which is typically a register, 'Wd', with or without an address modifier

However, word or byte-oriented file register instructions have two operands:

- The file register specified by the value, 'f'
- The destination, which could either be the file register, 'f', or the W0 register, which is denoted as 'WREG'

Most bit-oriented instructions (including simple rotate/shift instructions) have two operands:

- The W register (with or without an address modifier) or file register (specified by the value of 'Ws' or 'f')
- The bit in the W register or file register (specified by a literal value or indirectly by the contents of register, 'Wb')

The literal instructions that involve data movement may use some of the following operands:

- A literal value to be loaded into a W register or file register (specified by the value of 'k')
- The W register or file register where the literal value is to be loaded (specified by 'Wb' or 'f')

However, literal instructions that involve arithmetic or logical operations use some of the following operands:

- The first source operand, which is a register, 'Wb', without any address modifier
- The second source operand, which is a literal value
- The destination of the result (only if not the same as the first source operand), which is typically a register 'Wd' with or without an address modifier

The control instructions may use some of the following operands:

- A program memory address
- The mode of the table read and table write instructions

All instructions are a single word, except for certain double-word instructions, which were made double-word instructions so that all the required information is available in these 48 bits. In the second word, the 8 MSBs are '0's. If this second word is executed as an instruction (by itself), it will execute as a NOP.

Most single-word instructions are executed in a single instruction cycle, unless a conditional test is true or the program counter is changed as a result of the instruction. In these cases, the execution takes two instruction cycles, with the additional instruction cycle(s) executed as a NOP. Notable exceptions are the BRA (unconditional/computed branch), indirect CALL/GOTO, all table reads and writes, and RETURN/RETFIE instructions, which are single-word instructions but take two or three cycles.

Certain instructions that involve skipping over the subsequent instruction require either two or three cycles if the skip is performed, depending on whether the instruction being skipped is a single-word or two-word instruction. Moreover, double-word moves require two cycles. The double-word instructions execute in two instruction cycles.

# PIC24FJ256GA110 FAMILY

**TABLE 26-1: SYMBOLS USED IN OPCODE DESCRIPTIONS**

Field	Description
#text	Means literal defined by “text”
(text)	Means “content of text”
[text]	Means “the location addressed by text”
{ }	Optional field or operation
[n:m]	Register bit field
.b	Byte mode selection
.d	Double-Word mode selection
.S	Shadow register select
.w	Word mode selection (default)
bit4	4-bit bit selection field (used in word addressed instructions) $\in \{0...15\}$
C, DC, N, OV, Z	MCU Status bits: Carry, Digit Carry, Negative, Overflow, Sticky Zero
Expr	Absolute address, label or expression (resolved by the linker)
f	File register address $\in \{0000h...1FFFh\}$
lit1	1-bit unsigned literal $\in \{0,1\}$
lit4	4-bit unsigned literal $\in \{0...15\}$
lit5	5-bit unsigned literal $\in \{0...31\}$
lit8	8-bit unsigned literal $\in \{0...255\}$
lit10	10-bit unsigned literal $\in \{0...255\}$ for Byte mode, $\{0:1023\}$ for Word mode
lit14	14-bit unsigned literal $\in \{0...16384\}$
lit16	16-bit unsigned literal $\in \{0...65535\}$
lit23	23-bit unsigned literal $\in \{0...8388608\}$ ; LSB must be ‘0’
None	Field does not require an entry, may be blank
PC	Program Counter
Slit10	10-bit signed literal $\in \{-512...511\}$
Slit16	16-bit signed literal $\in \{-32768...32767\}$
Slit6	6-bit signed literal $\in \{-16...16\}$
Wb	Base W register $\in \{W0..W15\}$
Wd	Destination W register $\in \{Wd, [Wd], [Wd++] , [Wd--], [++Wd], [--Wd] \}$
Wdo	Destination W register $\in \{Wnd, [Wnd], [Wnd++] , [Wnd--], [++Wnd], [--Wnd], [Wnd+Wb] \}$
Wm,Wn	Dividend, Divisor Working Register pair (Direct Addressing)
Wn	One of 16 Working Registers $\in \{W0..W15\}$
Wnd	One of 16 destination Working Registers $\in \{W0..W15\}$
Wns	One of 16 source Working Registers $\in \{W0..W15\}$
WREG	W0 (Working Register used in file register instructions)
Ws	Source W register $\in \{Ws, [Ws], [Ws++] , [Ws--], [++Ws], [--Ws] \}$
Wso	Source W register $\in \{Wns, [Wns], [Wns++] , [Wns--], [++Wns], [--Wns], [Wns+Wb] \}$

# PIC24FJ256GA110 FAMILY

**TABLE 26-2: INSTRUCTION SET OVERVIEW**

Assembly Mnemonic	Assembly Syntax	Description	# of Words	# of Cycles	Status Flags Affected
ADD	ADD f	$f = f + WREG$	1	1	C, DC, N, OV, Z
	ADD f, WREG	$WREG = f + WREG$	1	1	C, DC, N, OV, Z
	ADD #lit10, Wn	$Wd = lit10 + Wd$	1	1	C, DC, N, OV, Z
	ADD Wb, Ws, Wd	$Wd = Wb + Ws$	1	1	C, DC, N, OV, Z
	ADD Wb, #lit5, Wd	$Wd = Wb + lit5$	1	1	C, DC, N, OV, Z
ADDC	ADDC f	$f = f + WREG + (C)$	1	1	C, DC, N, OV, Z
	ADDC f, WREG	$WREG = f + WREG + (C)$	1	1	C, DC, N, OV, Z
	ADDC #lit10, Wn	$Wd = lit10 + Wd + (C)$	1	1	C, DC, N, OV, Z
	ADDC Wb, Ws, Wd	$Wd = Wb + Ws + (C)$	1	1	C, DC, N, OV, Z
	ADDC Wb, #lit5, Wd	$Wd = Wb + lit5 + (C)$	1	1	C, DC, N, OV, Z
AND	AND f	$f = f .AND. WREG$	1	1	N, Z
	AND f, WREG	$WREG = f .AND. WREG$	1	1	N, Z
	AND #lit10, Wn	$Wd = lit10 .AND. Wd$	1	1	N, Z
	AND Wb, Ws, Wd	$Wd = Wb .AND. Ws$	1	1	N, Z
	AND Wb, #lit5, Wd	$Wd = Wb .AND. lit5$	1	1	N, Z
ASR	ASR f	f = Arithmetic Right Shift f	1	1	C, N, OV, Z
	ASR f, WREG	WREG = Arithmetic Right Shift f	1	1	C, N, OV, Z
	ASR Ws, Wd	Wd = Arithmetic Right Shift Ws	1	1	C, N, OV, Z
	ASR Wb, Wns, Wnd	Wnd = Arithmetic Right Shift Wb by Wns	1	1	N, Z
	ASR Wb, #lit5, Wnd	Wnd = Arithmetic Right Shift Wb by lit5	1	1	N, Z
BCLR	BCLR f, #bit4	Bit Clear f	1	1	None
	BCLR Ws, #bit4	Bit Clear Ws	1	1	None
BRA	BRA C, Expr	Branch if Carry	1	1 (2)	None
	BRA GE, Expr	Branch if Greater Than or Equal	1	1 (2)	None
	BRA GEU, Expr	Branch if Unsigned Greater Than or Equal	1	1 (2)	None
	BRA GT, Expr	Branch if Greater Than	1	1 (2)	None
	BRA GTU, Expr	Branch if Unsigned Greater Than	1	1 (2)	None
	BRA LE, Expr	Branch if Less Than or Equal	1	1 (2)	None
	BRA LEU, Expr	Branch if Unsigned Less Than or Equal	1	1 (2)	None
	BRA LT, Expr	Branch if Less Than	1	1 (2)	None
	BRA LTU, Expr	Branch if Unsigned Less Than	1	1 (2)	None
	BRA N, Expr	Branch if Negative	1	1 (2)	None
	BRA NC, Expr	Branch if Not Carry	1	1 (2)	None
	BRA NN, Expr	Branch if Not Negative	1	1 (2)	None
	BRA NOV, Expr	Branch if Not Overflow	1	1 (2)	None
	BRA NZ, Expr	Branch if Not Zero	1	1 (2)	None
	BRA OV, Expr	Branch if Overflow	1	1 (2)	None
	BRA Expr	Branch Unconditionally	1	2	None
	BRA Z, Expr	Branch if Zero	1	1 (2)	None
BRA Wn	Computed Branch	1	2	None	
BSET	BSET f, #bit4	Bit Set f	1	1	None
	BSET Ws, #bit4	Bit Set Ws	1	1	None
BSW	BSW.C Ws, Wb	Write C bit to Ws[Wb]	1	1	None
	BSW.Z Ws, Wb	Write Z bit to Ws[Wb]	1	1	None
BTG	BTG f, #bit4	Bit Toggle f	1	1	None
	BTG Ws, #bit4	Bit Toggle Ws	1	1	None
BTSC	BTSC f, #bit4	Bit Test f, Skip if Clear	1	1 (2 or 3)	None
	BTSC Ws, #bit4	Bit Test Ws, Skip if Clear	1	1 (2 or 3)	None

# PIC24FJ256GA110 FAMILY

**TABLE 26-2: INSTRUCTION SET OVERVIEW (CONTINUED)**

Assembly Mnemonic	Assembly Syntax	Description	# of Words	# of Cycles	Status Flags Affected
BTSS	BTSS $f, \#bit4$	Bit Test $f$ , Skip if Set	1	1 (2 or 3)	None
	BTSS $Ws, \#bit4$	Bit Test $Ws$ , Skip if Set	1	1 (2 or 3)	None
BTST	BTST $f, \#bit4$	Bit Test $f$	1	1	Z
	BTST.C $Ws, \#bit4$	Bit Test $Ws$ to C	1	1	C
	BTST.Z $Ws, \#bit4$	Bit Test $Ws$ to Z	1	1	Z
	BTST.C $Ws, Wb$	Bit Test $Ws[Wb]$ to C	1	1	C
	BTST.Z $Ws, Wb$	Bit Test $Ws[Wb]$ to Z	1	1	Z
BTSTS	BTSTS $f, \#bit4$	Bit Test then Set $f$	1	1	Z
	BTSTS.C $Ws, \#bit4$	Bit Test $Ws$ to C, then Set	1	1	C
	BTSTS.Z $Ws, \#bit4$	Bit Test $Ws$ to Z, then Set	1	1	Z
CALL	CALL $lit23$	Call Subroutine	2	2	None
	CALL $Wn$	Call Indirect Subroutine	1	2	None
CLR	CLR $f$	$f = 0x0000$	1	1	None
	CLR $WREG$	$WREG = 0x0000$	1	1	None
	CLR $Ws$	$Ws = 0x0000$	1	1	None
CLRWDT	CLRWDT	Clear Watchdog Timer	1	1	WDTO, Sleep
COM	COM $f$	$f = \bar{f}$	1	1	N, Z
	COM $f, WREG$	$WREG = \bar{f}$	1	1	N, Z
	COM $Ws, Wd$	$Wd = \bar{Ws}$	1	1	N, Z
CP	CP $f$	Compare $f$ with $WREG$	1	1	C, DC, N, OV, Z
	CP $Wb, \#lit5$	Compare $Wb$ with $lit5$	1	1	C, DC, N, OV, Z
	CP $Wb, Ws$	Compare $Wb$ with $Ws$ ( $Wb - Ws$ )	1	1	C, DC, N, OV, Z
CP0	CP0 $f$	Compare $f$ with $0x0000$	1	1	C, DC, N, OV, Z
	CP0 $Ws$	Compare $Ws$ with $0x0000$	1	1	C, DC, N, OV, Z
CPB	CPB $f$	Compare $f$ with $WREG$ , with Borrow	1	1	C, DC, N, OV, Z
	CPB $Wb, \#lit5$	Compare $Wb$ with $lit5$ , with Borrow	1	1	C, DC, N, OV, Z
	CPB $Wb, Ws$	Compare $Wb$ with $Ws$ , with Borrow ( $Wb - Ws - C$ )	1	1	C, DC, N, OV, Z
CPSEQ	CPSEQ $Wb, Wn$	Compare $Wb$ with $Wn$ , Skip if =	1	1 (2 or 3)	None
CPSGT	CPSGT $Wb, Wn$	Compare $Wb$ with $Wn$ , Skip if >	1	1 (2 or 3)	None
CPSLT	CPSLT $Wb, Wn$	Compare $Wb$ with $Wn$ , Skip if <	1	1 (2 or 3)	None
CPSNE	CPSNE $Wb, Wn$	Compare $Wb$ with $Wn$ , Skip if $\neq$	1	1 (2 or 3)	None
DAW	DAW.b $Wn$	$Wn =$ Decimal Adjust $Wn$	1	1	C
DEC	DEC $f$	$f = f - 1$	1	1	C, DC, N, OV, Z
	DEC $f, WREG$	$WREG = f - 1$	1	1	C, DC, N, OV, Z
	DEC $Ws, Wd$	$Wd = Ws - 1$	1	1	C, DC, N, OV, Z
DEC2	DEC2 $f$	$f = f - 2$	1	1	C, DC, N, OV, Z
	DEC2 $f, WREG$	$WREG = f - 2$	1	1	C, DC, N, OV, Z
	DEC2 $Ws, Wd$	$Wd = Ws - 2$	1	1	C, DC, N, OV, Z
DISI	DISI $\#lit14$	Disable Interrupts for $k$ Instruction Cycles	1	1	None
DIV	DIV.SW $Wm, Wn$	Signed 16/16-bit Integer Divide	1	18	N, Z, C, OV
	DIV.SD $Wm, Wn$	Signed 32/16-bit Integer Divide	1	18	N, Z, C, OV
	DIV.UW $Wm, Wn$	Unsigned 16/16-bit Integer Divide	1	18	N, Z, C, OV
	DIV.UD $Wm, Wn$	Unsigned 32/16-bit Integer Divide	1	18	N, Z, C, OV
EXCH	EXCH $Wns, Wnd$	Swap $Wns$ with $Wnd$	1	1	None
FF1L	FF1L $Ws, Wnd$	Find First One from Left (MSb) Side	1	1	C
FF1R	FF1R $Ws, Wnd$	Find First One from Right (LSb) Side	1	1	C

# PIC24FJ256GA110 FAMILY

**TABLE 26-2: INSTRUCTION SET OVERVIEW (CONTINUED)**

Assembly Mnemonic	Assembly Syntax	Description	# of Words	# of Cycles	Status Flags Affected
GOTO	GOTO Expr	Go to Address	2	2	None
	GOTO Wn	Go to Indirect	1	2	None
INC	INC f	$f = f + 1$	1	1	C, DC, N, OV, Z
	INC f, WREG	WREG = $f + 1$	1	1	C, DC, N, OV, Z
	INC Ws, Wd	Wd = Ws + 1	1	1	C, DC, N, OV, Z
INC2	INC2 f	$f = f + 2$	1	1	C, DC, N, OV, Z
	INC2 f, WREG	WREG = $f + 2$	1	1	C, DC, N, OV, Z
	INC2 Ws, Wd	Wd = Ws + 2	1	1	C, DC, N, OV, Z
IOR	IOR f	$f = f .IOR. WREG$	1	1	N, Z
	IOR f, WREG	WREG = $f .IOR. WREG$	1	1	N, Z
	IOR #lit10, Wn	Wd = lit10 .IOR. Wd	1	1	N, Z
	IOR Wb, Ws, Wd	Wd = Wb .IOR. Ws	1	1	N, Z
	IOR Wb, #lit5, Wd	Wd = Wb .IOR. lit5	1	1	N, Z
LNK	LNK #lit14	Link Frame Pointer	1	1	None
LSR	LSR f	f = Logical Right Shift f	1	1	C, N, OV, Z
	LSR f, WREG	WREG = Logical Right Shift f	1	1	C, N, OV, Z
	LSR Ws, Wd	Wd = Logical Right Shift Ws	1	1	C, N, OV, Z
	LSR Wb, Wns, Wnd	Wnd = Logical Right Shift Wb by Wns	1	1	N, Z
	LSR Wb, #lit5, Wnd	Wnd = Logical Right Shift Wb by lit5	1	1	N, Z
MOV	MOV f, Wn	Move f to Wn	1	1	None
	MOV [Wns+Slit10], Wnd	Move [Wns+Slit10] to Wnd	1	1	None
	MOV f	Move f to f	1	1	N, Z
	MOV f, WREG	Move f to WREG	1	1	N, Z
	MOV #lit16, Wn	Move 16-bit Literal to Wn	1	1	None
	MOV.b #lit8, Wn	Move 8-bit Literal to Wn	1	1	None
	MOV Wn, f	Move Wn to f	1	1	None
	MOV Wns, [Wns+Slit10]	Move Wns to [Wns+Slit10]	1	1	
	MOV Wso, Wdo	Move Ws to Wd	1	1	None
	MOV WREG, f	Move WREG to f	1	1	N, Z
	MOV.D Wns, Wd	Move Double from W(ns):W(ns + 1) to Wd	1	2	None
	MOV.D Ws, Wnd	Move Double from Ws to W(nd + 1):W(nd)	1	2	None
MUL	MUL.SS Wb, Ws, Wnd	{Wnd + 1, Wnd} = Signed(Wb) * Signed(Ws)	1	1	None
	MUL.SU Wb, Ws, Wnd	{Wnd + 1, Wnd} = Signed(Wb) * Unsigned(Ws)	1	1	None
	MUL.US Wb, Ws, Wnd	{Wnd + 1, Wnd} = Unsigned(Wb) * Signed(Ws)	1	1	None
	MUL.UU Wb, Ws, Wnd	{Wnd + 1, Wnd} = Unsigned(Wb) * Unsigned(Ws)	1	1	None
	MUL.SU Wb, #lit5, Wnd	{Wnd + 1, Wnd} = Signed(Wb) * Unsigned(lit5)	1	1	None
	MUL.UU Wb, #lit5, Wnd	{Wnd + 1, Wnd} = Unsigned(Wb) * Unsigned(lit5)	1	1	None
	MUL f	W3:W2 = f * WREG	1	1	None
NEG	NEG f	$f = \bar{f} + 1$	1	1	C, DC, N, OV, Z
	NEG f, WREG	WREG = $\bar{f} + 1$	1	1	C, DC, N, OV, Z
	NEG Ws, Wd	Wd = $\overline{Ws} + 1$	1	1	C, DC, N, OV, Z
NOP	NOP	No Operation	1	1	None
	NOPR	No Operation	1	1	None
POP	POP f	Pop f from Top-of-Stack (TOS)	1	1	None
	POP Wdo	Pop from Top-of-Stack (TOS) to Wdo	1	1	None
	POP.D Wnd	Pop from Top-of-Stack (TOS) to W(nd):W(nd + 1)	1	2	None
	POP.S	Pop Shadow Registers	1	1	All
PUSH	PUSH f	Push f to Top-of-Stack (TOS)	1	1	None
	PUSH Wso	Push Wso to Top-of-Stack (TOS)	1	1	None
	PUSH.D Wns	Push W(ns):W(ns + 1) to Top-of-Stack (TOS)	1	2	None
	PUSH.S	Push Shadow Registers	1	1	None

# PIC24FJ256GA110 FAMILY

**TABLE 26-2: INSTRUCTION SET OVERVIEW (CONTINUED)**

Assembly Mnemonic	Assembly Syntax	Description	# of Words	# of Cycles	Status Flags Affected
PWRSVAV	PWRSVAV #lit1	Go into Sleep or Idle mode	1	1	WDTO, Sleep
RCALL	RCALL Expr	Relative Call	1	2	None
	RCALL Wn	Computed Call	1	2	None
REPEAT	REPEAT #lit14	Repeat Next Instruction lit14 + 1 Times	1	1	None
	REPEAT Wn	Repeat Next Instruction (Wn) + 1 Times	1	1	None
RESET	RESET	Software Device Reset	1	1	None
RETFIE	RETFIE	Return from Interrupt	1	3 (2)	None
RETLW	RETLW #lit10, Wn	Return with Literal in Wn	1	3 (2)	None
RETURN	RETURN	Return from Subroutine	1	3 (2)	None
RLC	RLC f	f = Rotate Left through Carry f	1	1	C, N, Z
	RLC f, WREG	WREG = Rotate Left through Carry f	1	1	C, N, Z
	RLC Ws, Wd	Wd = Rotate Left through Carry Ws	1	1	C, N, Z
RLNC	RLNC f	f = Rotate Left (No Carry) f	1	1	N, Z
	RLNC f, WREG	WREG = Rotate Left (No Carry) f	1	1	N, Z
	RLNC Ws, Wd	Wd = Rotate Left (No Carry) Ws	1	1	N, Z
RRC	RRC f	f = Rotate Right through Carry f	1	1	C, N, Z
	RRC f, WREG	WREG = Rotate Right through Carry f	1	1	C, N, Z
	RRC Ws, Wd	Wd = Rotate Right through Carry Ws	1	1	C, N, Z
RRNC	RRNC f	f = Rotate Right (No Carry) f	1	1	N, Z
	RRNC f, WREG	WREG = Rotate Right (No Carry) f	1	1	N, Z
	RRNC Ws, Wd	Wd = Rotate Right (No Carry) Ws	1	1	N, Z
SE	SE Ws, Wnd	Wnd = Sign-Extended Ws	1	1	C, N, Z
SETM	SETM f	f = FFFFh	1	1	None
	SETM WREG	WREG = FFFFh	1	1	None
	SETM Ws	Ws = FFFFh	1	1	None
SL	SL f	f = Left Shift f	1	1	C, N, OV, Z
	SL f, WREG	WREG = Left Shift f	1	1	C, N, OV, Z
	SL Ws, Wd	Wd = Left Shift Ws	1	1	C, N, OV, Z
	SL Wb, Wns, Wnd	Wnd = Left Shift Wb by Wns	1	1	N, Z
	SL Wb, #lit5, Wnd	Wnd = Left Shift Wb by lit5	1	1	N, Z
SUB	SUB f	f = f - WREG	1	1	C, DC, N, OV, Z
	SUB f, WREG	WREG = f - WREG	1	1	C, DC, N, OV, Z
	SUB #lit10, Wn	Wn = Wn - lit10	1	1	C, DC, N, OV, Z
	SUB Wb, Ws, Wd	Wd = Wb - Ws	1	1	C, DC, N, OV, Z
	SUB Wb, #lit5, Wd	Wd = Wb - lit5	1	1	C, DC, N, OV, Z
SUBB	SUBB f	f = f - WREG - ( $\overline{C}$ )	1	1	C, DC, N, OV, Z
	SUBB f, WREG	WREG = f - WREG - ( $\overline{C}$ )	1	1	C, DC, N, OV, Z
	SUBB #lit10, Wn	Wn = Wn - lit10 - ( $\overline{C}$ )	1	1	C, DC, N, OV, Z
	SUBB Wb, Ws, Wd	Wd = Wb - Ws - ( $\overline{C}$ )	1	1	C, DC, N, OV, Z
	SUBB Wb, #lit5, Wd	Wd = Wb - lit5 - ( $\overline{C}$ )	1	1	C, DC, N, OV, Z
SUBR	SUBR f	f = WREG - f	1	1	C, DC, N, OV, Z
	SUBR f, WREG	WREG = WREG - f	1	1	C, DC, N, OV, Z
	SUBR Wb, Ws, Wd	Wd = Ws - Wb	1	1	C, DC, N, OV, Z
	SUBR Wb, #lit5, Wd	Wd = lit5 - Wb	1	1	C, DC, N, OV, Z
SUBBR	SUBBR f	f = WREG - f - ( $\overline{C}$ )	1	1	C, DC, N, OV, Z
	SUBBR f, WREG	WREG = WREG - f - ( $\overline{C}$ )	1	1	C, DC, N, OV, Z
	SUBBR Wb, Ws, Wd	Wd = Ws - Wb - ( $\overline{C}$ )	1	1	C, DC, N, OV, Z
	SUBBR Wb, #lit5, Wd	Wd = lit5 - Wb - ( $\overline{C}$ )	1	1	C, DC, N, OV, Z
SWAP	SWAP.b Wn	Wn = Nibble Swap Wn	1	1	None
	SWAP Wn	Wn = Byte Swap Wn	1	1	None

# PIC24FJ256GA110 FAMILY

**TABLE 26-2: INSTRUCTION SET OVERVIEW (CONTINUED)**

Assembly Mnemonic	Assembly Syntax	Description	# of Words	# of Cycles	Status Flags Affected
TBLRDH	TBLRDH <i>Ws, Wd</i>	Read Prog[23:16] to Wd[7:0]	1	2	None
TBLRDL	TBLRDL <i>Ws, Wd</i>	Read Prog[15:0] to Wd	1	2	None
TBLWTH	TBLWTH <i>Ws, Wd</i>	Write Ws[7:0] to Prog[23:16]	1	2	None
TBLWTL	TBLWTL <i>Ws, Wd</i>	Write Ws to Prog[15:0]	1	2	None
ULNK	ULNK	Unlink Frame Pointer	1	1	None
XOR	XOR <i>f</i>	$f = f .XOR. WREG$	1	1	N, Z
	XOR <i>f, WREG</i>	$WREG = f .XOR. WREG$	1	1	N, Z
	XOR <i>#lit10, Wn</i>	$Wd = lit10 .XOR. Wd$	1	1	N, Z
	XOR <i>Wb, Ws, Wd</i>	$Wd = Wb .XOR. Ws$	1	1	N, Z
	XOR <i>Wb, #lit5, Wd</i>	$Wd = Wb .XOR. lit5$	1	1	N, Z
ZE	ZE <i>Ws, Wnd</i>	$Wnd = Zero-Extend Ws$	1	1	C, Z, N

# PIC24FJ256GA110 FAMILY

---

NOTES:

# PIC24FJ256GA110 FAMILY

---

## 27.0 DEVELOPMENT SUPPORT

Move a design from concept to production in record time with Microchip's award-winning development tools. Microchip tools work together to provide state of the art debugging for any project with easy-to-use Graphical User Interfaces (GUIs) in our free MPLAB® X and Atmel Studio Integrated Development Environments (IDEs), and our code generation tools. Providing the ultimate ease-of-use experience, Microchip's line of programmers, debuggers and emulators work seamlessly with our software tools. Microchip development boards help evaluate the best silicon device for an application, while our line of third party tools round out our comprehensive development tool solutions.

Microchip's MPLAB X and Atmel Studio ecosystems provide a variety of embedded design tools to consider, which support multiple devices, such as PIC® MCUs, AVR® MCUs, SAM MCUs and dsPIC® DSCs. MPLAB X tools are compatible with Windows®, Linux® and Mac® operating systems while Atmel Studio tools are compatible with Windows.

Go to the following website for more information and details:

<https://www.microchip.com/development-tools/>

# PIC24FJ256GA110 FAMILY

---

NOTES:

# PIC24FJ256GA110 FAMILY

## 28.0 ELECTRICAL CHARACTERISTICS

This section provides an overview of the PIC24FJ256GA110 family electrical characteristics. Additional information will be provided in future revisions of this document as it becomes available.

Absolute maximum ratings for the PIC24FJ256GA110 family are listed below. Exposure to these maximum rating conditions for extended periods may affect device reliability. Functional operation of the device at these, or any other conditions above the parameters indicated in the operation listings of this specification, is not implied.

### Absolute Maximum Ratings<sup>(†)</sup>

Ambient temperature under bias .....	-40°C to +135°C
Storage temperature .....	-65°C to +150°C
Voltage on VDD with respect to VSS .....	-0.3V to +4.0V
Voltage on any combined analog and digital pin, and MCLR with respect to VSS .....	-0.3V to (VDD + 0.3V)
Voltage on any digital only pin with respect to VSS .....	-0.3V to +6.0V
Voltage on VDDCORE with respect to VSS .....	-0.3V to +3.0V
Maximum current out of VSS pin .....	300 mA
Maximum current into VDD pin ( <b>Note 1</b> ).....	250 mA
Maximum output current sunk by any I/O pin.....	25 mA
Maximum output current sourced by any I/O pin .....	25 mA
Maximum current sunk by all ports .....	200 mA
Maximum current sourced by all ports ( <b>Note 1</b> ).....	200 mA

**Note 1:** Maximum allowable current is a function of device maximum power dissipation (see [Table 28-1](#)).

† **NOTICE:** Stresses above those listed under “Absolute Maximum Ratings” may cause permanent damage to the device. This is a stress rating only and functional operation of the device at those or any other conditions above those indicated in the operation listings of this specification is not implied. Exposure to maximum rating conditions for extended periods may affect device reliability.

# PIC24FJ256GA110 FAMILY

## 28.1 DC Characteristics

FIGURE 28-1: PIC24FJ256GA110 FAMILY VOLTAGE-FREQUENCY GRAPH (INDUSTRIAL)

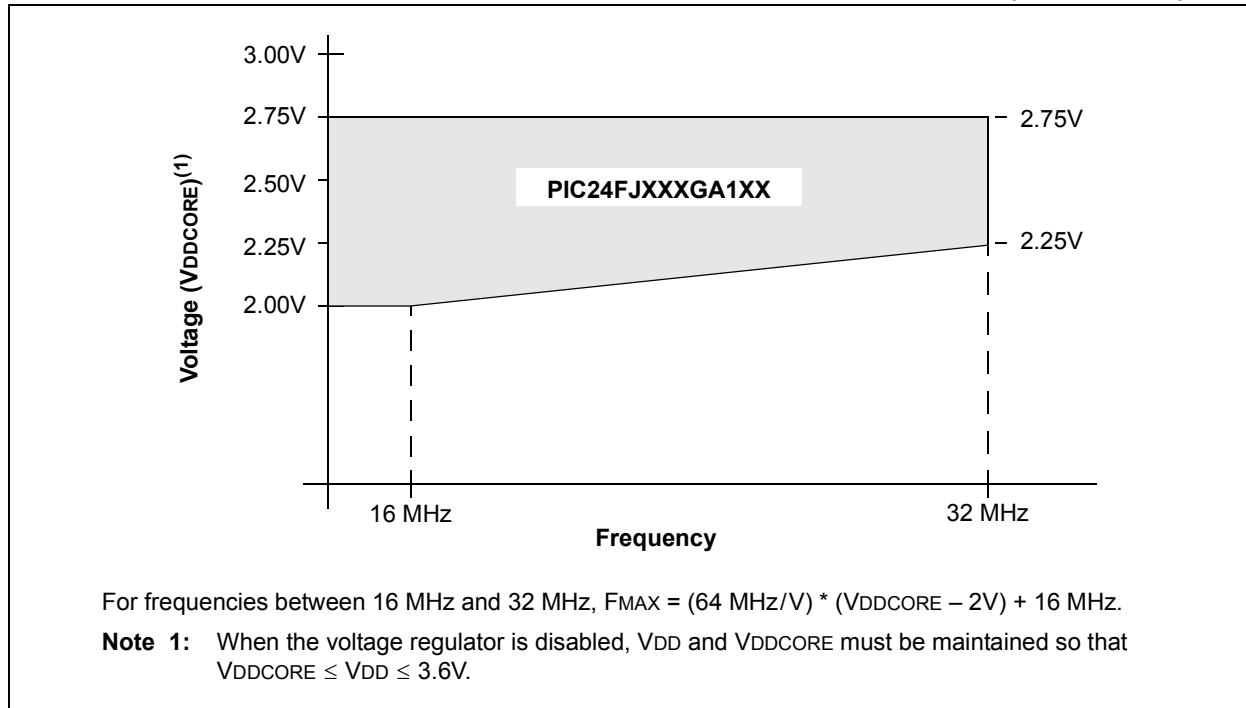


TABLE 28-1: THERMAL OPERATING CONDITIONS

Rating	Symbol	Min	Typ	Max	Unit
PIC24FJ256GA110 Family:					
Operating Junction Temperature Range	TJ	-40	—	+140	°C
Operating Ambient Temperature Range	TA	-40	—	+125	°C
Power Dissipation: Internal Chip Power Dissipation: $P_{INT} = V_{DD} \times (I_{DD} - \sum I_{OH})$ I/O Pin Power Dissipation: $P_{I/O} = \sum (\{V_{DD} - V_{OH}\} \times I_{OH}) + \sum (V_{OL} \times I_{OL})$	PD	PINT + PI/O			W
Maximum Allowed Power Dissipation	PDMAX	$(T_J - T_A) / \theta_{JA}$			W

TABLE 28-2: THERMAL PACKAGING CHARACTERISTICS

Characteristic	Symbol	Typ	Max	Unit	Notes
Package Thermal Resistance, 14x14x1 mm TQFP	$\theta_{JA}$	50.0	—	°C/W	(Note 1)
Package Thermal Resistance, 12x12x1 mm TQFP	$\theta_{JA}$	69.4	—	°C/W	(Note 1)
Package Thermal Resistance, 10x10x1 mm TQFP	$\theta_{JA}$	76.6	—	°C/W	(Note 1)
Package Thermal Resistance, 9x9x0.9 mm QFN	$\theta_{JA}$	28.0	—	°C/W	(Note 1)

**Note 1:** Junction to ambient thermal resistance, Theta-JA ( $\theta_{JA}$ ) numbers are achieved by package simulations.

# PIC24FJ256GA110 FAMILY

**TABLE 28-3: DC CHARACTERISTICS: TEMPERATURE AND VOLTAGE SPECIFICATIONS**

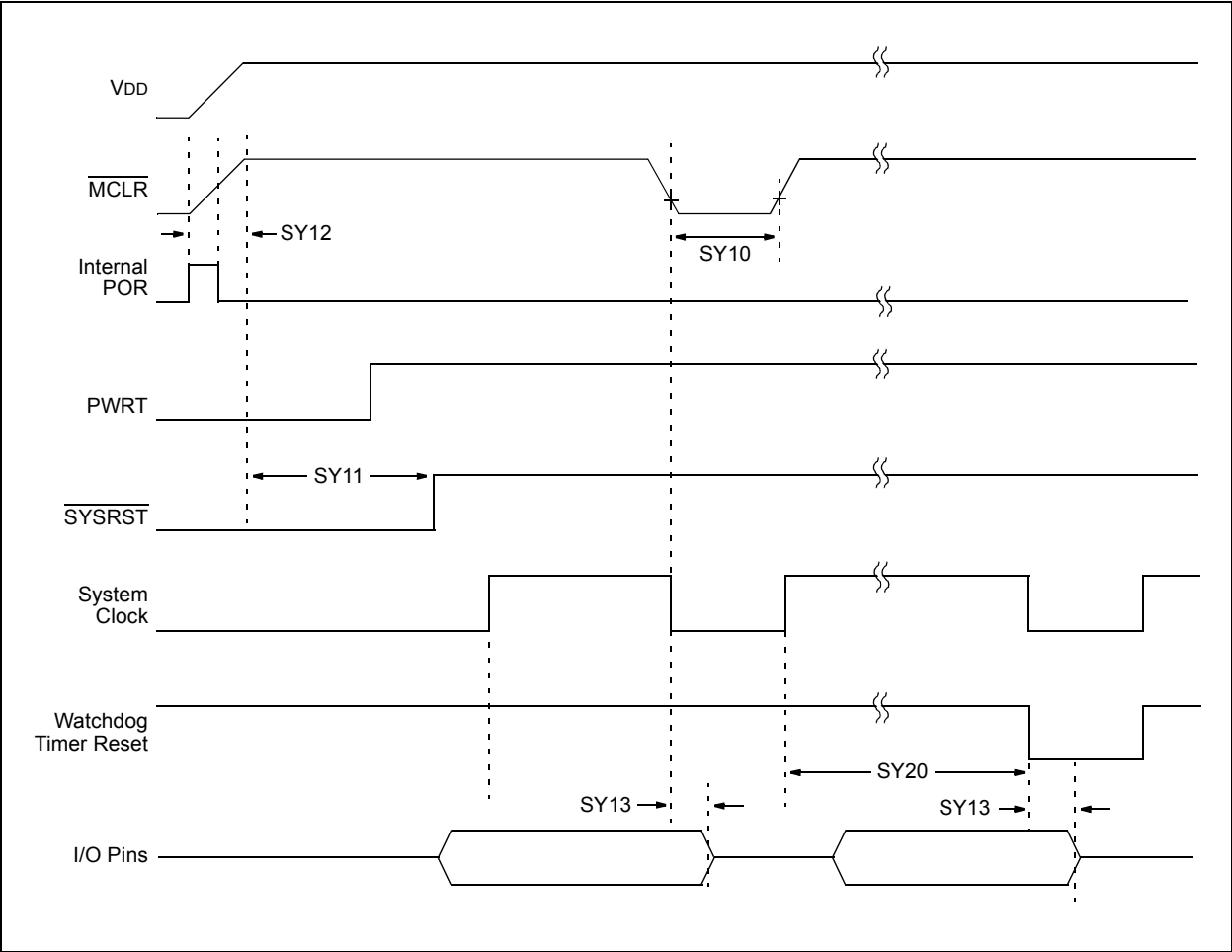
DC CHARACTERISTICS			Standard Operating Conditions: 2.0V to 3.6V (unless otherwise stated)				
			Operating temperature -40°C ≤ TA ≤ +85°C for Industrial -40°C ≤ TA ≤ +125°C for Extended				
Param No.	Symbol	Characteristic	Min	Typ <sup>(1)</sup>	Max	Units	Conditions
<b>Operating Voltage</b>							
DC10	<b>Supply Voltage</b>						
	VDD		VBOR	—	3.6	V	Regulator enabled
	VDD		VDDCORE	—	3.6	V	Regulator disabled
	VDDCORE		2.0	—	2.75	V	Regulator disabled
DC12	VDR	<b>RAM Data Retention Voltage<sup>(2)</sup></b>	1.5	—	—	V	
DC16	VPOR	<b>VDD Start Voltage</b> to Ensure Internal Power-on Reset Signal	VSS	—	—	V	
DC17	SVDD	<b>VDD Rise Rate</b> to Ensure Internal Power-on Reset Signal	0.05	—	—	V/ms	0-3.3V in 0.1s 0-2.5V in 60 ms
BO10	VBOR	<b>Brown-Out Reset Voltage</b>	1.90	2.10	2.25	V	
BO15	VBHYS	<b>BOR Hysteresis</b>	—	5	—	mV	

**Note 1:** Data in “Typ” column are at 3.3V, +25°C unless otherwise stated. Parameters are for design guidance only and are not tested.

**2:** This is the limit to which VDD can be lowered without losing RAM data.

# PIC24FJ256GA110 FAMILY

**FIGURE 28-2: RESET, WATCHDOG TIMER, OSCILLATOR START-UP TIMER AND POWER-UP TIMER TIMING CHARACTERISTICS**



# PIC24FJ256GA110 FAMILY

**TABLE 28-4: DC CHARACTERISTICS: OPERATING CURRENT (IDD)**

DC CHARACTERISTICS			Standard Operating Conditions: 2.0V to 3.6V (unless otherwise stated)	
			Operating temperature -40°C ≤ TA ≤ +85°C for Industrial -40°C ≤ TA ≤ +125°C for Extended	
Parameter No.	Typical <sup>(1)</sup>	Max	Units	Conditions
<b>Operating Current (IDD): PMD Bits are Set<sup>(2)</sup></b>				
DC20	0.83	1.2	mA	-40°C
DC20a	0.83	1.2	mA	+25°C
DC20b	0.83	1.2	mA	+85°C
DC20c	0.9	1.3	mA	+125°C
DC20d	1.1	1.7	mA	-40°C
DC20e	1.1	1.7	mA	+25°C
DC20f	1.1	1.7	mA	+85°C
DC20g	1.2	1.7	mA	+125°C
DC23	3.3	4.5	mA	-40°C
DC23a	3.3	4.5	mA	+25°C
DC23b	3.3	4.6	mA	+85°C
DC23c	3.4	4.6	mA	+125°C
DC23d	4.3	6.5	mA	-40°C
DC23e	4.3	6.5	mA	+25°C
DC23f	4.3	6.5	mA	+85°C
DC23g	4.3	6.5	mA	+125°C
DC24	18.2	24.0	mA	-40°C
DC24a	18.2	24.0	mA	+25°C
DC24b	18.2	24.0	mA	+85°C
DC24c	18.2	24.0	mA	+125°C
DC24d	18.2	24.0	mA	-40°C
DC24e	18.2	24.0	mA	+25°C
DC24f	18.2	24.0	mA	+85°C
DC24g	18.2	24.0	mA	+125°C
DC31	15.0	54.0	µA	-40°C
DC31a	15.0	54.0	µA	+25°C
DC31b	20.0	69.0	µA	+85°C
DC31c	60.0	159.0	µA	+125°C
DC31d	57.0	96.0	µA	-40°C
DC31e	57.0	96.0	µA	+25°C
DC31f	95.0	145.0	µA	+85°C
DC31g	120.0	281.0	µA	+125°C

- Note 1:** Data in “Typical” column are at 3.3V, 25°C unless otherwise stated. Parameters are for design guidance only and are not tested.
- 2:** The supply current is mainly a function of the operating voltage and frequency. Other factors, such as I/O pin loading and switching rate, oscillator type, internal code execution pattern and temperature, also have an impact on the current consumption. The test conditions for all IDD measurements are as follows: OSCI driven with external square wave from rail to rail. All I/O pins are configured as inputs and pulled to VDD. MCLR = VDD; WDT and FSCM are disabled. CPU, SRAM, program memory and data memory are operational. No peripheral modules are operating and all of the Peripheral Module Disable (PMD) bits are set.
- 3:** On-chip voltage regulator disabled (ENVREG tied to Vss).
- 4:** On-chip voltage regulator enabled (ENVREG tied to VDD).

# PIC24FJ256GA110 FAMILY

**TABLE 28-5: DC CHARACTERISTICS: IDLE CURRENT (IDLE)**

DC CHARACTERISTICS			Standard Operating Conditions: 2.0V to 3.6V (unless otherwise stated) Operating temperature -40°C ≤ TA ≤ +85°C for Industrial -40°C ≤ TA ≤ +125°C for Extended	
Parameter No.	Typical <sup>(1)</sup>	Max	Units	Conditions
<b>Idle Current (IDLE): Core Off, Clock On Base Current, PMD Bits are Set<sup>(2)</sup></b>				
DC40	220	310	μA	-40°C
DC40a	220	310	μA	+25°C
DC40b	220	310	μA	+85°C
DC40c	260	350	μA	+125°C
DC40d	300	390	μA	-40°C
DC40e	300	390	μA	+25°C
DC40f	320	420	μA	+85°C
DC40g	340	450	μA	+125°C
DC43	0.85	1.1	mA	-40°C
DC43a	0.85	1.1	mA	+25°C
DC43b	0.87	1.2	mA	+85°C
DC43c	0.87	1.2	mA	+125°C
DC43d	1.1	1.4	mA	-40°C
DC43e	1.1	1.4	mA	+25°C
DC43f	1.1	1.4	mA	+85°C
DC43g	1.1	1.5	mA	+125°C
DC47	4.4	5.6	mA	-40°C
DC47a	4.4	5.6	mA	+25°C
DC47b	4.4	5.6	mA	+85°C
DC47c	4.4	5.6	mA	+125°C
DC47d	4.4	5.6	mA	-40°C
DC47e	4.4	5.6	mA	+25°C
DC47f	4.4	5.6	mA	+85°C
DC47g	4.4	5.6	mA	+125°C
DC50	1.1	1.4	mA	-40°C
DC50a	1.1	1.4	mA	+25°C
DC50b	1.1	1.4	mA	+85°C
DC50c	1.2	1.5	mA	+125°C
DC50d	1.4	1.8	mA	-40°C
DC50e	1.4	1.8	mA	+25°C
DC50f	1.4	1.8	mA	+85°C
DC50g	1.4	1.8	mA	+125°C

- Note 1:** Data in "Typical" column are at 3.3V, +25°C unless otherwise stated. Parameters are for design guidance only and are not tested.
- 2:** Base IDLE current is measured with core off, clock on, all modules off and all of the Peripheral Module Disable (PMD) bits are set.
- 3:** On-chip voltage regulator disabled (ENVREG tied to Vss).
- 4:** On-chip voltage regulator enabled (ENVREG tied to VDD).

# PIC24FJ256GA110 FAMILY

**TABLE 28-5: DC CHARACTERISTICS: IDLE CURRENT (IDLE) (CONTINUED)**

DC CHARACTERISTICS			Standard Operating Conditions: 2.0V to 3.6V (unless otherwise stated)	
			Operating temperature -40°C ≤ TA ≤ +85°C for Industrial -40°C ≤ TA ≤ +125°C for Extended	
Parameter No.	Typical <sup>(1)</sup>	Max	Units	Conditions
<b>Idle Current (IDLE): Core Off, Clock On Base Current, PMD Bits are Set<sup>(2)</sup></b>				
DC51	4.3	13.0	μA	-40°C
DC51a	4.5	13.0	μA	+25°C
DC51b	10	32	μA	+85°C
DC51c	40	115	μA	+125°C
DC51d	44	77	μA	-40°C
DC51e	44	77	μA	+25°C
DC51f	70	132	μA	+85°C
DC51g	130	217	μA	+125°C

- Note 1:** Data in “Typical” column are at 3.3V, +25°C unless otherwise stated. Parameters are for design guidance only and are not tested.
- 2:** Base IDLE current is measured with core off, clock on, all modules off and all of the Peripheral Module Disable (PMD) bits are set.
- 3:** On-chip voltage regulator disabled (ENVREG tied to Vss).
- 4:** On-chip voltage regulator enabled (ENVREG tied to VDD).

# PIC24FJ256GA110 FAMILY

**TABLE 28-6: DC CHARACTERISTICS: POWER-DOWN CURRENT (IPD)**

DC CHARACTERISTICS			Standard Operating Conditions: 2.0V to 3.6V (unless otherwise stated)	
			Operating temperature -40°C ≤ TA ≤ +85°C for Industrial -40°C ≤ TA ≤ +125°C for Extended	
Parameter No.	Typical <sup>(1)</sup>	Max	Units	Conditions
<b>Power-Down Current (IPD): PMD Bits are Set, PMSLP Bit is '0'<sup>(2)</sup></b>				
DC60	0.1	1.0	μA	-40°C
DC60a	0.15	1.0	μA	+25°C
DC60m	2.25	11	μA	+60°C
DC60b	3.7	18.0	μA	+85°C
DC60j	18.0	85.0	μA	+125°C
DC60c	0.2	1.4	μA	-40°C
DC60d	0.25	1.4	μA	+25°C
DC60n	2.6	16.5	μA	+60°C
DC60e	4.2	27	μA	+85°C
DC60k	20.0	110	μA	+125°C
DC60f	3.6	10.0	μA	-40°C
DC60g	4.0	10	μA	+25°C
DC60p	8.1	25.2	μA	+60°C
DC60h	11.0	36	μA	+85°C
DC60l	36.0	120	μA	+125°C
DC61	1.75	3	μA	-40°C
DC61a	1.75	3	μA	+25°C
DC61m	1.75	3	μA	+60°C
DC61b	1.75	3	μA	+85°C
DC61j	3.5	6	μA	+125°C
DC61c	2.4	4	μA	-40°C
DC61d	2.4	4	μA	+25°C
DC61n	2.4	4	μA	+60°C
DC61e	2.4	4	μA	+85°C
DC61k	4.8	8	μA	+125°C
DC61f	2.8	5	μA	-40°C
DC61g	2.8	5	μA	+25°C
DC61p	2.8	5	μA	+60°C
DC61h	2.8	5	μA	+85°C
DC61l	5.6	10	μA	+125°C

**Note 1:** Data in "Typical" column are at 3.3V, +25°C unless otherwise stated. Parameters are for design guidance only and are not tested.

- 2:** Base IPD is measured with all peripherals and clocks shut down. All I/Os are configured as inputs and pulled high. WDT, etc., are all switched off.
- 3:** On-chip voltage regulator disabled (ENVREG tied to VSS).
- 4:** On-chip voltage regulator enabled (ENVREG tied to VDD).
- 5:** The Δ current is the additional current consumed when the module is enabled. This current should be added to the base IPD current.

# PIC24FJ256GA110 FAMILY

**TABLE 28-6: DC CHARACTERISTICS: POWER-DOWN CURRENT (I<sub>PD</sub>) (CONTINUED)**

DC CHARACTERISTICS			Standard Operating Conditions: 2.0V to 3.6V (unless otherwise stated)	
			Operating temperature -40°C ≤ T <sub>A</sub> ≤ +85°C for Industrial -40°C ≤ T <sub>A</sub> ≤ +125°C for Extended	
Parameter No.	Typical <sup>(1)</sup>	Max	Units	Conditions
<b>Power-Down Current (I<sub>PD</sub>): PMD Bits are Set, PMSLP Bit is '0'<sup>(2)</sup></b>				
DC62	2.5	7.0	μA	-40°C
DC62a	2.5	7.0	μA	+25°C
DC62m	3.0	7.0	μA	+60°C
DC62b	3.0	7.0	μA	+85°C
DC62j	6.0	12.0	μA	+125°C
DC62c	2.8	7.0	μA	-40°C
DC62d	3.0	7.0	μA	+25°C
DC62n	3.0	7.0	μA	+60°C
DC62e	3.0	7.0	μA	+85°C
DC62k	6.0	12.0	μA	+125°C
DC62f	3.5	10.0	μA	-40°C
DC62g	3.5	10.0	μA	+25°C
DC62p	4.0	10.0	μA	+60°C
DC62h	4.0	10.0	μA	+85°C
DC62l	8.0	18.0	μA	+125°C

- Note 1:** Data in "Typical" column are at 3.3V, +25°C unless otherwise stated. Parameters are for design guidance only and are not tested.
- 2:** Base I<sub>PD</sub> is measured with all peripherals and clocks shut down. All I/Os are configured as inputs and pulled high. WDT, etc., are all switched off.
- 3:** On-chip voltage regulator disabled (ENVREG tied to V<sub>SS</sub>).
- 4:** On-chip voltage regulator enabled (ENVREG tied to V<sub>DD</sub>).
- 5:** The Δ current is the additional current consumed when the module is enabled. This current should be added to the base I<sub>PD</sub> current.

# PIC24FJ256GA110 FAMILY

**TABLE 28-7: DC CHARACTERISTICS: I/O PIN INPUT SPECIFICATIONS**

DC CHARACTERISTICS			Standard Operating Conditions: 2.0V to 3.6V (unless otherwise stated) Operating temperature $-40^{\circ}\text{C} \leq T_A \leq +85^{\circ}\text{C}$ for Industrial $-40^{\circ}\text{C} \leq T_A \leq +125^{\circ}\text{C}$ for Extended				
Param No.	Sym	Characteristic	Min	Typ <sup>(1)</sup>	Max	Units	Conditions
	V <sub>IL</sub>	<b>Input Low Voltage<sup>(4)</sup></b>					
DI10		I/O Pins with ST Buffer	V <sub>SS</sub>	—	0.2 V <sub>DD</sub>	V	
DI11		I/O Pins with TTL Buffer	V <sub>SS</sub>	—	0.15 V <sub>DD</sub>	V	
DI15		$\overline{\text{MCLR}}$	V <sub>SS</sub>	—	0.2 V <sub>DD</sub>	V	
DI16		OSC1 (XT mode)	V <sub>SS</sub>	—	0.2 V <sub>DD</sub>	V	
DI17		OSC1 (HS mode)	V <sub>SS</sub>	—	0.2 V <sub>DD</sub>	V	
DI18		I/O Pins with I <sup>2</sup> C Buffer	V <sub>SS</sub>	—	0.3 V <sub>DD</sub>	V	
DI19		I/O Pins with SMBus Buffer	V <sub>SS</sub>	—	0.8	V	SMBus enabled
	V <sub>IH</sub>	<b>Input High Voltage<sup>(4)</sup></b>					
DI20		I/O Pins with ST Buffer: with Analog Functions Digital Only	0.8 V <sub>DD</sub> 0.8 V <sub>DD</sub>	— —	V <sub>DD</sub> 5.5	V V	
DI21		I/O Pins with TTL Buffer: with Analog Functions Digital Only	0.25 V <sub>DD</sub> + 0.8 0.25 V <sub>DD</sub> + 0.8	— —	V <sub>DD</sub> 5.5	V V	
DI25		$\overline{\text{MCLR}}$	0.8 V <sub>DD</sub>	—	V <sub>DD</sub>	V	
DI26		OSC1 (XT mode)	0.7 V <sub>DD</sub>	—	V <sub>DD</sub>	V	
DI27		OSC1 (HS mode)	0.7 V <sub>DD</sub>	—	V <sub>DD</sub>	V	
DI28		I/O Pins with I <sup>2</sup> C Buffer: with Analog Functions Digital Only	0.7 V <sub>DD</sub> 0.7 V <sub>DD</sub>	— —	V <sub>DD</sub> 5.5	V V	
DI29		I/O Pins with SMBus Buffer: with Analog Functions Digital Only	2.1 2.1		V <sub>DD</sub> 5.5	V V	2.5V ≤ V <sub>PIN</sub> ≤ V <sub>DD</sub>
DI30	ICNPU	<b>CN<sub>x</sub> Pull-up Current</b>	50	250	400	μA	V <sub>DD</sub> = 3.3V, V <sub>PIN</sub> = 0
DI30A	ICNPD	<b>CN<sub>x</sub> Pull-Down Current</b>	—	80	—	μA	V <sub>DD</sub> = 3.3V, V <sub>PIN</sub> = V <sub>DD</sub>

- Note 1:** Data in “Typ” column are at 3.3V, +25°C unless otherwise stated. Parameters are for design guidance only and are not tested.
- 2:** The leakage current on the  $\overline{\text{MCLR}}$  pin is strongly dependent on the applied voltage level. The specified levels represent normal operating conditions. Higher leakage current may be measured at different input voltages.
- 3:** Negative current is defined as current sourced by the pin.
- 4:** Refer to [Table 1-4](#) for I/O pin buffer types.
- 5:** Parameter characterized but not tested.
- 6:** Non-5V tolerant pins: V<sub>IH</sub> source > (V<sub>DD</sub> + 0.3), 5V tolerant pins: V<sub>IH</sub> source > 5.5V. Characterized but not tested.
- 7:** Digital 5V tolerant pins cannot tolerate any “positive” input injection current from input sources greater than 5.5V.
- 8:** Injection currents > |0| can affect the performance of all analog peripherals (e.g., A/D, comparators, internal band gap reference, etc.).
- 9:** Any number and/or combination of I/O pins not excluded under I<sub>CL</sub> or I<sub>CH</sub> conditions is permitted provided the mathematical “absolute instantaneous” sum of the input injection currents from all pins do not exceed the specified limit. Characterized but not tested.

# PIC24FJ256GA110 FAMILY

**TABLE 28-7: DC CHARACTERISTICS: I/O PIN INPUT SPECIFICATIONS (CONTINUED)**

DC CHARACTERISTICS			Standard Operating Conditions: 2.0V to 3.6V (unless otherwise stated) Operating temperature -40°C ≤ TA ≤ +85°C for Industrial -40°C ≤ TA ≤ +125°C for Extended				
Param No.	Sym	Characteristic	Min	Typ <sup>(1)</sup>	Max	Units	Conditions
DI31	IPU	Maximum Load Current for Digital High Detection w/Internal Pull-up	— —	— —	30 100	μA μA	VDD = 2.0V VDD = 3.3V
DI50	IIL	Input Leakage Current <sup>(2,3)</sup> I/O Ports	—	—	±1	μA	VSS ≤ VPIN ≤ VDD, pin at high-impedance, -40°C ≤ TA ≤ +85°C
			—	—	±3	μA	VSS ≤ VPIN ≤ VDD, pin at high-impedance, -40°C ≤ TA ≤ +125°C
DI51		Analog Input Pins	—	—	±1	μA	VSS ≤ VPIN ≤ VDD, pin at high-impedance, -40°C ≤ TA ≤ +85°C
			—	—	±3	μA	VSS ≤ VPIN ≤ VDD, pin at high-impedance, -40°C ≤ TA ≤ +125°C
DI55		MCLR	—	—	±1	μA	VSS ≤ VPIN ≤ VDD, -40°C ≤ TA ≤ +85°C
			—	—	±3	μA	VSS ≤ VPIN ≤ VDD, -40°C ≤ TA ≤ +125°C
DI56		OSC1	—	—	±1	μA	VSS ≤ VPIN ≤ VDD, XT and HS modes, -40°C ≤ TA ≤ +85°C
			—	—	±3	μA	VSS ≤ VPIN ≤ VDD, XT and HS modes, -40°C ≤ TA ≤ +125°C

- Note 1:** Data in “Typ” column are at 3.3V, +25°C unless otherwise stated. Parameters are for design guidance only and are not tested.
- 2:** The leakage current on the  $\overline{\text{MCLR}}$  pin is strongly dependent on the applied voltage level. The specified levels represent normal operating conditions. Higher leakage current may be measured at different input voltages.
- 3:** Negative current is defined as current sourced by the pin.
- 4:** Refer to [Table 1-4](#) for I/O pin buffer types.
- 5:** Parameter characterized but not tested.
- 6:** Non-5V tolerant pins: VIH source > (VDD + 0.3), 5V tolerant pins: VIH source > 5.5V. Characterized but not tested.
- 7:** Digital 5V tolerant pins cannot tolerate any “positive” input injection current from input sources greater than 5.5V.
- 8:** Injection currents > | 0 | can affect the performance of all analog peripherals (e.g., A/D, comparators, internal band gap reference, etc.).
- 9:** Any number and/or combination of I/O pins not excluded under IICL or IICH conditions is permitted provided the mathematical “absolute instantaneous” sum of the input injection currents from all pins do not exceed the specified limit. Characterized but not tested.

# PIC24FJ256GA110 FAMILY

**TABLE 28-7: DC CHARACTERISTICS: I/O PIN INPUT SPECIFICATIONS (CONTINUED)**

DC CHARACTERISTICS		Standard Operating Conditions: 2.0V to 3.6V (unless otherwise stated) Operating temperature -40°C ≤ TA ≤ +85°C for Industrial -40°C ≤ TA ≤ +125°C for Extended					
Param No.	Sym	Characteristic	Min	Typ <sup>(1)</sup>	Max	Units	Conditions
DI60a	I <sub>ICL</sub>	Input Low Injection Current	0	—	-5 <sup>(5,8)</sup>	mA	All pins, except V <sub>DD</sub> , V <sub>SS</sub> , AV <sub>DD</sub> , AV <sub>SS</sub> , M <sub>CLR</sub> , V <sub>CAP</sub> , RB11, SOSC <sub>I</sub> , SOSC <sub>O</sub> , D+, D-, V <sub>USB</sub> and V <sub>BUS</sub>
DI60b	I <sub>ICH</sub>	Input High Injection Current	0	—	+5 <sup>(6,7,8)</sup>	mA	All pins, except V <sub>DD</sub> , V <sub>SS</sub> , AV <sub>DD</sub> , AV <sub>SS</sub> , M <sub>CLR</sub> , V <sub>CAP</sub> , RB11, SOSC <sub>I</sub> , SOSC <sub>O</sub> , D+, D-, V <sub>USB</sub> and V <sub>BUS</sub> , and all 5V tolerant pins <sup>(7)</sup>
DI60c	ΣI <sub>ICT</sub>	Total Input Injection Current (sum of all I/O and control pins)	-20 <sup>(9)</sup>	—	+20 <sup>(9)</sup>	mA	Absolute instantaneous sum of all ± input injection currents from all I/O pins (   I <sub>ICL</sub> +   I <sub>ICH</sub>   ) ≤ ΣI <sub>ICT</sub>

- Note 1:** Data in “Typ” column are at 3.3V, +25°C unless otherwise stated. Parameters are for design guidance only and are not tested.
- 2:** The leakage current on the  $\overline{\text{MCLR}}$  pin is strongly dependent on the applied voltage level. The specified levels represent normal operating conditions. Higher leakage current may be measured at different input voltages.
- 3:** Negative current is defined as current sourced by the pin.
- 4:** Refer to [Table 1-4](#) for I/O pin buffer types.
- 5:** Parameter characterized but not tested.
- 6:** Non-5V tolerant pins: V<sub>IH</sub> source > (V<sub>DD</sub> + 0.3), 5V tolerant pins: V<sub>IH</sub> source > 5.5V. Characterized but not tested.
- 7:** Digital 5V tolerant pins cannot tolerate any “positive” input injection current from input sources greater than 5.5V.
- 8:** Injection currents > | 0 | can affect the performance of all analog peripherals (e.g., A/D, comparators, internal band gap reference, etc.).
- 9:** Any number and/or combination of I/O pins not excluded under I<sub>ICL</sub> or I<sub>ICH</sub> conditions is permitted provided the mathematical “absolute instantaneous” sum of the input injection currents from all pins do not exceed the specified limit. Characterized but not tested.

# PIC24FJ256GA110 FAMILY

**TABLE 28-8: DC CHARACTERISTICS: I/O PIN OUTPUT SPECIFICATIONS**

DC CHARACTERISTICS			Standard Operating Conditions: 2.0V to 3.6V (unless otherwise stated) Operating temperature $-40^{\circ}\text{C} \leq T_A \leq +85^{\circ}\text{C}$ for Industrial $-40^{\circ}\text{C} \leq T_A \leq +125^{\circ}\text{C}$ for Extended				
Param No.	Sym	Characteristic	Min	Typ <sup>(1)</sup>	Max	Units	Conditions
DO10	VOL	<b>Output Low Voltage</b> I/O Ports	—	—	0.4	V	IOL = 8.5 mA, VDD = 3.6V
DO16			—	—	0.4	V	IOL = 6.0 mA, VDD = 2.0V
	VOH	<b>Output High Voltage</b> I/O Ports	—	—	0.4	V	IOL = 8.5 mA, VDD = 3.6V
			—	—	0.4	V	IOL = 6.0 mA, VDD = 2.0V
DO20			3.0	—	—	V	IOH = -3.0 mA, VDD = 3.6V
			2.4	—	—	V	IOH = -6.0 mA, VDD = 3.6V
			1.65	—	—	V	IOH = -1.0 mA, VDD = 2.0V
			1.4	—	—	V	IOH = -3.0 mA, VDD = 2.0V
DO26	OSC2/CLKO		3.0	—	—	V	IOH = -2.5 mA, VDD = 3.6V
			1.65	—	—	V	IOH = -0.5 mA, VDD = 2.0V

**Note 1:** Data in “Typ” column are at 3.3V, 25°C unless otherwise stated. Parameters are for design guidance only and are not tested.

**TABLE 28-9: DC CHARACTERISTICS: PROGRAM MEMORY**

DC CHARACTERISTICS			Standard Operating Conditions: 2.0V to 3.6V (unless otherwise stated) Operating temperature $-40^{\circ}\text{C} \leq T_A \leq +85^{\circ}\text{C}$ for Industrial $-40^{\circ}\text{C} \leq T_A \leq +125^{\circ}\text{C}$ for Extended				
Param No.	Sym	Characteristic	Min	Typ <sup>(1)</sup>	Max	Units	Conditions
D130	EP	Cell Endurance	10000	—	—	E/W	$-40^{\circ}\text{C}$ to $+85^{\circ}\text{C}$
D131	VPR	VDD for Read	VMIN	—	3.6	V	VMIN = Minimum operating voltage
D132A	VPEW	Supply Voltage for Self-Timed Writes:	2.25	—	VDDCORE	V	
D132B			VDD	2.35	—	3.6	V
D133A	TIW	Self-Timed Write Cycle Time	—	3	—	ms	
D133B	TIE	Self-Timed Page Erase Time	40	—	—	ms	
D134	TRETD	Characteristic Retention	20	—	—	Year	Provided no other specifications are violated
D135	IDDP	Supply Current During Programming	—	7	—	mA	

**Note 1:** Data in “Typ” column are at 3.3V, +25°C unless otherwise stated.

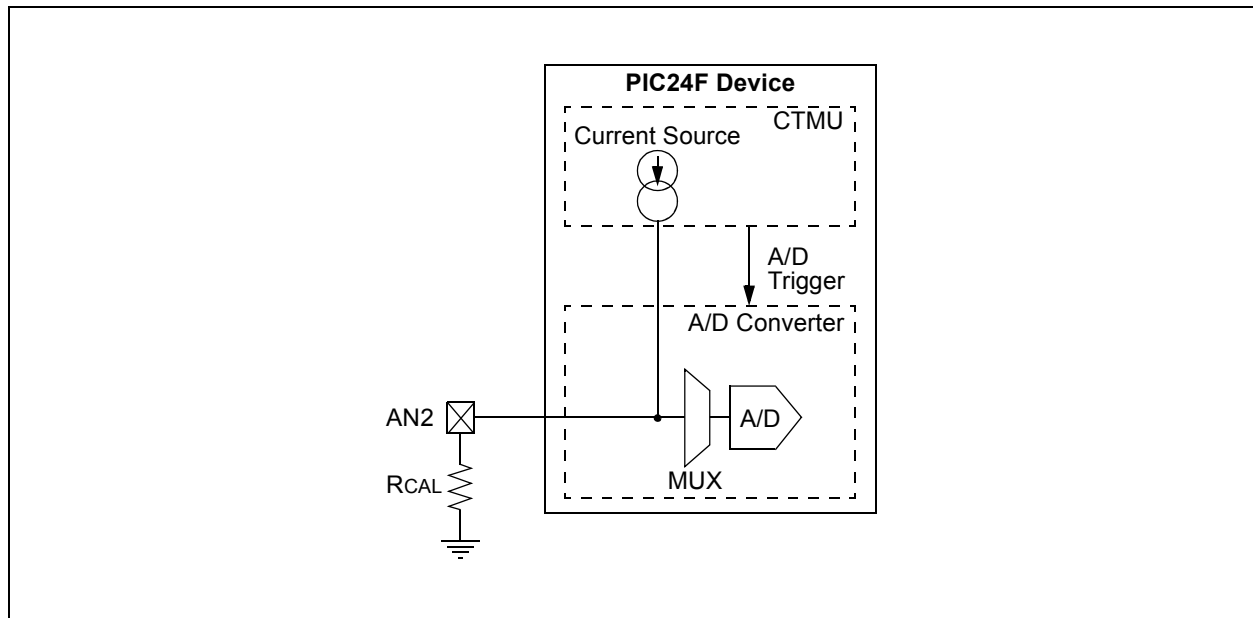
# PIC24FJ256GA110 FAMILY

**TABLE 28-10: INTERNAL VOLTAGE REGULATOR SPECIFICATIONS**

DC CHARACTERISTICS			Standard Operating Conditions: 2.0V to 3.6V (unless otherwise stated) Operating temperature -40°C ≤ TA ≤ +85°C for Industrial -40°C ≤ TA ≤ +125°C for Extended				
Param No.	Symbol	Characteristics	Min	Typ	Max	Units	Comments
	VRGOUT	Regulator Output Voltage	—	2.5	—	V	
	VBG	Internal Band Gap Reference <sup>(1)</sup>	1.14	1.2	1.26	V	
	CEFC	External Filter Capacitor Value	4.7	10	—	μF	Series resistance < 3 Ohm recommended; < 5 Ohm required.
	TVREG	Regulator Start-up Time	—	10	—	μs	PMSLP = 1, or any POR or BOR Wake for Sleep when PMSLP = 0
			—	250	—	μs	
	TBG	Band Gap Reference Start-up Time	—	—	1	ms	

**Note 1:** Parameter is characterized but not tested.

**FIGURE 28-3: CTMU CURRENT SOURCE CALIBRATION CIRCUIT**



# PIC24FJ256GA110 FAMILY

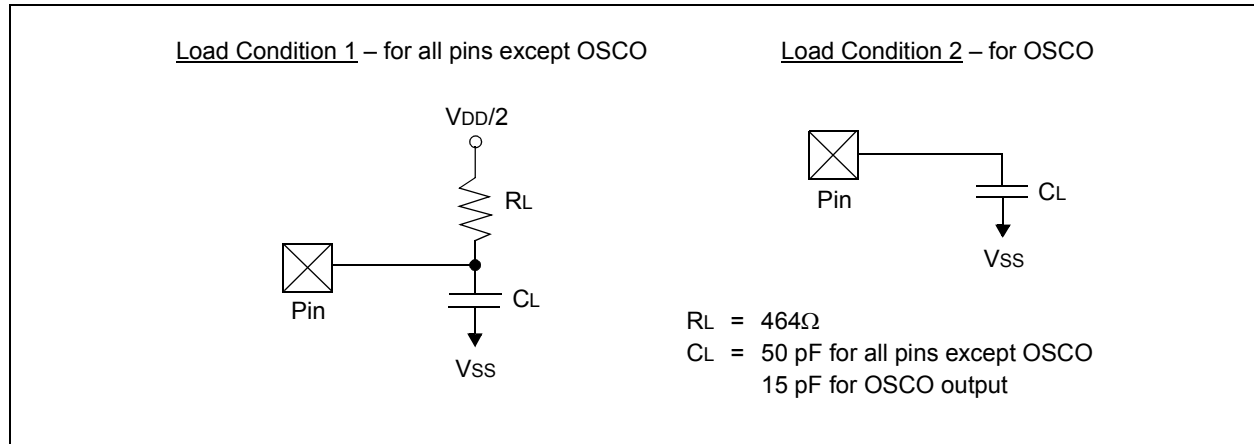
## 28.2 AC Characteristics and Timing Parameters

The information contained in this section defines the PIC24FJ256GA110 family AC characteristics and timing parameters.

**TABLE 28-11: TEMPERATURE AND VOLTAGE SPECIFICATIONS – AC**

<b>AC CHARACTERISTICS</b>	<b>Standard Operating Conditions: 2.0V to 3.6V (unless otherwise stated)</b>
	Operating temperature $-40^{\circ}\text{C} \leq T_A \leq +85^{\circ}\text{C}$ for Industrial $-40^{\circ}\text{C} \leq T_A \leq +125^{\circ}\text{C}$ for Extended
	Operating voltage $V_{DD}$ range as described in <a href="#">Section 28.1 “DC Characteristics”</a> .

**FIGURE 28-4: LOAD CONDITIONS FOR DEVICE TIMING SPECIFICATIONS**



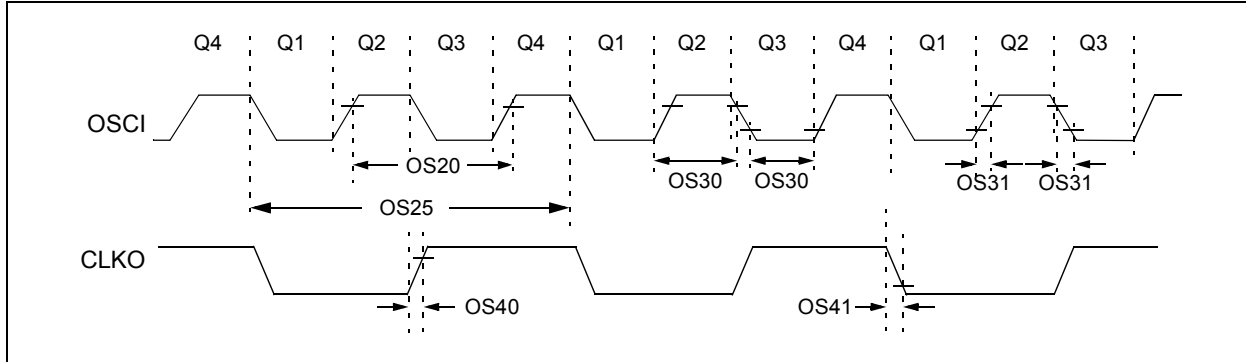
**TABLE 28-12: CAPACITIVE LOADING REQUIREMENTS ON OUTPUT PINS**

Param No.	Symbol	Characteristic	Min	Typ <sup>(1)</sup>	Max	Units	Conditions
DO50	Cosc2	OSCO/CLKO Pin	—	—	15	pF	In XT and HS modes when external clock is used to drive OSC1
DO56	Cio	All I/O Pins and OSCO	—	—	50	pF	EC mode
DO58	CB	SCLx, SDAx	—	—	400	pF	In I <sup>2</sup> C mode

**Note 1:** Data in “Typ” column are at 3.3V, +25°C unless otherwise stated. Parameters are for design guidance only and are not tested.

# PIC24FJ256GA110 FAMILY

**FIGURE 28-5: EXTERNAL CLOCK TIMING**



**TABLE 28-13: EXTERNAL CLOCK TIMING REQUIREMENTS**

AC CHARACTERISTICS			Standard Operating Conditions: 2.50 to 3.6V (unless otherwise stated) Operating temperature -40°C ≤ TA ≤ +85°C for Industrial -40°C ≤ TA ≤ +125°C for Extended				
Param No.	Sym	Characteristic	Min	Typ <sup>(1)</sup>	Max	Units	Conditions
OS10	Fosc	External CLKI Frequency (external clocks allowed only in EC mode)	DC 4	—	32 8	MHz MHz	EC, -40°C ≤ TA ≤ +85°C ECPLL, -40°C ≤ TA ≤ +85°C
		Oscillator Frequency	DC 4	—	24 6	MHz MHz	EC, -40°C ≤ TA ≤ +125°C ECPLL, -40°C ≤ TA ≤ +125°C
OS10	Fosc	Oscillator Frequency	3	—	10	MHz	XT XTPLL, -40°C ≤ TA ≤ +85°C HS, -40°C ≤ TA ≤ +85°C SOSC XTPLL, -40°C ≤ TA ≤ +125°C HS, -40°C ≤ TA ≤ +125°C
			3	—	8	MHz	
			10	—	32	MHz	
			31	—	33	kHz	
			3	—	6	MHz	
			10	—	24	MHz	
OS20	Tosc	Tosc = 1/Fosc	—	—	—	—	See Parameter OS10 for Fosc value
OS25	Tcy	Instruction Cycle Time <sup>(2)</sup>	62.5	—	DC	ns	
OS30	TosL, TosH	External Clock in (OSCI) High or Low Time	0.45 x Tosc	—	—	ns	EC
OS31	TosR, TosF	External Clock in (OSCI) Rise or Fall Time	—	—	20	ns	EC
OS40	TckR	CLKO Rise Time <sup>(3)</sup>	—	6	10	ns	
OS41	TckF	CLKO Fall Time <sup>(3)</sup>	—	6	10	ns	

**Note 1:** Data in "Typ" column are at 3.3V, +25°C unless otherwise stated. Parameters are for design guidance only and are not tested.

**2:** Instruction cycle period (Tcy) equals two times the input oscillator time base period. All specified values are based on characterization data for that particular oscillator type under standard operating conditions with the device executing code. Exceeding these specified limits may result in an unstable oscillator operation and/or higher than expected current consumption. All devices are tested to operate at "Min." values with an external clock applied to the OSCI/CLKI pin. When an external clock input is used, the "Max." cycle time limit is "DC" (no clock) for all devices.

**3:** Measurements are taken in EC mode. The CLKO signal is measured on the OSCO pin. CLKO is low for the Q1-Q2 period (1/2 Tcy) and high for the Q3-Q4 period (1/2 Tcy).

# PIC24FJ256GA110 FAMILY

**TABLE 28-14: PLL CLOCK TIMING SPECIFICATIONS (V<sub>DD</sub> = 2.0V TO 3.6V)**

AC CHARACTERISTICS			Standard Operating Conditions: 2.0V to 3.6V (unless otherwise stated) Operating temperature -40°C ≤ T <sub>A</sub> ≤ +85°C for Industrial -40°C ≤ T <sub>A</sub> ≤ +125°C for Extended				
Param No.	Sym	Characteristic <sup>(1)</sup>	Min	Typ <sup>(2)</sup>	Max	Units	Conditions
OS50	FPLLI	PLL Input Frequency Range	4	—	8	MHz	ECPLL, HSPLL, XTPLL modes
OS51	FSYS	PLL Output Frequency Range	16	—	32	MHz	
OS52	TLOCK	PLL Start-up Time (Lock Time)	—	—	2	ms	
OS53	DCLK	CLKO Stability (Jitter)	-2	1	+2	%	

**Note 1:** These parameters are characterized but not tested in manufacturing.

**2:** Data in “Typ” column are at 3.3V, +25°C unless otherwise stated. Parameters are for design guidance only and are not tested.

**TABLE 28-15: INTERNAL RC OSCILLATOR SPECIFICATIONS**

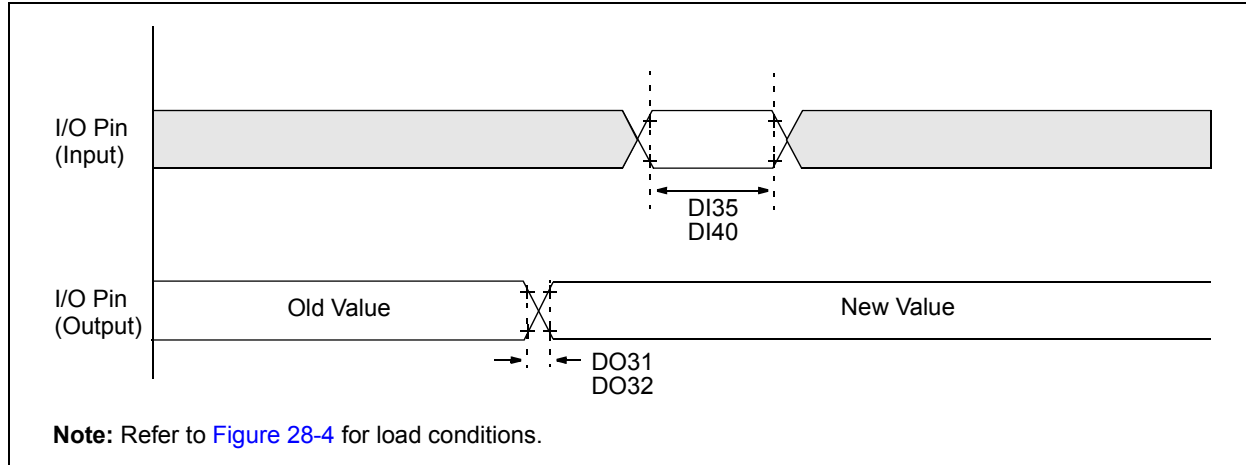
AC CHARACTERISTICS			Standard Operating Conditions: 2.0V to 3.6V (unless otherwise stated) Operating temperature -40°C ≤ T <sub>A</sub> ≤ +85°C for Industrial -40°C ≤ T <sub>A</sub> ≤ +125°C for Extended				
Param No.	Sym	Characteristic	Min	Typ	Max	Units	Conditions
F20	TFRC	FRC Start-up Time	—	15	—	μs	
		FRC Accuracy @ 8 MHz <sup>(1)</sup>	-2	—	2	%	+25°C, 3.0V ≤ V <sub>DD</sub> ≤ 3.6V
			-5	—	5	%	-40°C ≤ T <sub>A</sub> ≤ +85°C, 3.0V ≤ V <sub>DD</sub> ≤ 3.6V
		-6.5	—	6.5	%	-40°C ≤ T <sub>A</sub> ≤ +125°C, 3.0V ≤ V <sub>DD</sub> ≤ 3.6V	
F21	TLPRC	LPRC Start-up Time	—	40	—	μs	
		LPRC Accuracy @ 31 kHz <sup>(2)</sup>	-20	—	20	%	-40°C ≤ T <sub>A</sub> ≤ +85°C, 3.0V ≤ V <sub>DD</sub> ≤ 3.6V
			-30	—	30	%	+85°C ≤ T <sub>A</sub> ≤ +125°C

**Note 1:** Frequency calibrated at +25°C and 3.3V. OSCTUN bits can be used to compensate for temperature drift.

**2:** Change of LPRC frequency as V<sub>DD</sub> changes.

# PIC24FJ256GA110 FAMILY

**FIGURE 28-6: CLKO AND I/O TIMING CHARACTERISTICS**



**TABLE 28-16: CLKO AND I/O TIMING REQUIREMENTS**

AC CHARACTERISTICS			Standard Operating Conditions: 2.0V to 3.6V (unless otherwise stated) Operating temperature $-40^{\circ}\text{C} \leq T_A \leq +85^{\circ}\text{C}$ for Industrial $-40^{\circ}\text{C} \leq T_A \leq +125^{\circ}\text{C}$ for Extended				
Param No.	Sym	Characteristic	Min	Typ <sup>(1)</sup>	Max	Units	Conditions
DO31	TioR	Port Output Rise Time	—	10	25	ns	
DO32	TioF	Port Output Fall Time	—	10	25	ns	
DI35	TINP	INTx Pin High or Low Time (output)	20	—	—	ns	
DI40	TRBP	CNx High or Low Time (input)	2	—	—	Tcy	

**Note 1:** Data in “Typ” column are at 3.3V, +25°C unless otherwise stated.

**TABLE 28-17: RESET SPECIFICATIONS**

AC CHARACTERISTICS			Standard Operating Conditions: 2.0V to 3.6V (unless otherwise stated) Operating temperature $-40^{\circ}\text{C} \leq T_A \leq +85^{\circ}\text{C}$ for Industrial $-40^{\circ}\text{C} \leq T_A \leq +125^{\circ}\text{C}$ for Extended				
Sym	Characteristic	Min	Typ <sup>(1)</sup>	Max	Units	Conditions	
TPOR	Power-up Time	—	2	—	$\mu\text{s}$		
TRST	Internal State Reset Time	—	50	—	$\mu\text{s}$		
TPWRT		—	64	—	ms	ENVREG tied to Vss	

**Note 1:** Data in “Typ” column are at 3.3V, +25°C unless otherwise stated.

# PIC24FJ256GA110 FAMILY

**TABLE 28-18: A/D MODULE SPECIFICATIONS**

AC CHARACTERISTICS			Standard Operating Conditions: 2.0V to 3.6V (unless otherwise stated) Operating temperature $-40^{\circ}\text{C} \leq T_A \leq +85^{\circ}\text{C}$ for Industrial $-40^{\circ}\text{C} \leq T_A \leq +125^{\circ}\text{C}$ for Extended				
Param No.	Symbol	Characteristic	Min.	Typ	Max.	Units	Conditions
<b>Device Supply</b>							
AD01	AVDD	Module VDD Supply	Greater of: VDD – 0.3 or 2.0	—	Lesser of: VDD + 0.3 or 3.6	V	
AD02	AVSS	Module Vss Supply	Vss – 0.3	—	Vss + 0.3	V	
<b>Reference Inputs</b>							
AD05	VREFH	Reference Voltage High	AVss + 1.7	—	AVDD	V	
AD06	VREFL	Reference Voltage Low	AVss	—	AVDD – 1.7	V	
AD07	VREF	Absolute Reference Voltage	AVss – 0.3	—	AVDD + 0.3	V	
AD08	IVREF	Reference Voltage Input Current	—	—	1.25	mA	(Note 3)
AD09	ZVREF	Reference Input Impedance	—	10K	—	$\Omega$	(Note 4)
<b>Analog Input</b>							
AD10	VINH-VINL	Full-Scale Input Span	VREFL	—	VREFH	V	(Note 2)
AD11	VIN	Absolute Input Voltage	AVss – 0.3	—	AVDD + 0.3	V	
AD12	VINL	Absolute VINL Input Voltage	AVss – 0.3	—	AVDD/2	V	
AD17	RIN	Recommended Impedance of Analog Voltage Source	—	—	2.5K	$\Omega$	10-bit
<b>ADC Accuracy</b>							
AD20b	NR	Resolution	—	10	—	bits	
AD21b	INL	Integral Nonlinearity	—	$\pm 1$	$< \pm 2$	LSb	VINL = AVSS = VREFL = 0V, AVDD = VREFH = 3V
AD22b	DNL	Differential Nonlinearity	—	$\pm 0.5$	$< \pm 1$	LSb	VINL = AVSS = VREFL = 0V, AVDD = VREFH = 3V
AD23b	GERR	Gain Error	—	$\pm 1$	$\pm 3$	LSb	VINL = AVSS = VREFL = 0V, AVDD = VREFH = 3V
AD24b	E0FF	Offset Error	—	$\pm 1$	$\pm 2$	LSb	VINL = AVSS = VREFL = 0V, AVDD = VREFH = 3V
AD25b		Monotonicity <sup>(1)</sup>	—	—	—	—	Guaranteed

**Note 1:** The ADC conversion result never decreases with an increase in the input voltage and has no missing codes.

**2:** Measurements taken with external VREF+ and VREF- are used as the ADC voltage reference.

**3:** External reference voltage applied to VREF+/- pins. IVREF is current during conversion at 3.3V, +25°C. Parameter is for design guidance only and is not tested.

**4:** Impedance during sampling is at 3.3V, +25°C. Parameter is for design guidance only and is not tested.

# PIC24FJ256GA110 FAMILY

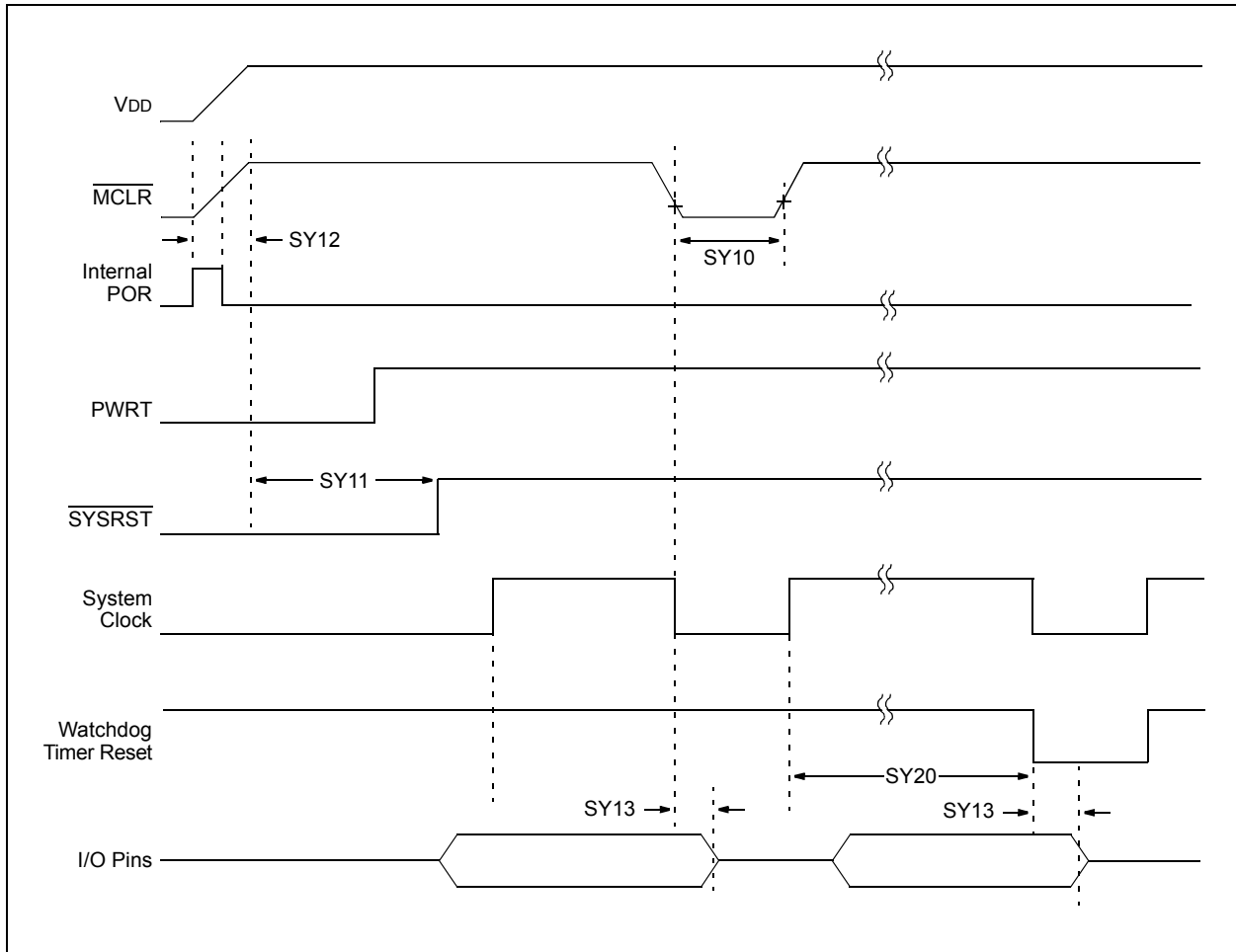
**TABLE 28-19: A/D CONVERSION TIMING REQUIREMENTS<sup>(1)</sup>**

AC CHARACTERISTICS			Standard Operating Conditions: 2.0V to 3.6V (unless otherwise stated) Operating temperature -40°C ≤ TA ≤ +85°C for Industrial -40°C ≤ TA ≤ +125°C for Extended				
Param No.	Symbol	Characteristic	Min.	Typ	Max.	Units	Conditions
<b>Clock Parameters</b>							
AD50	TAD	ADC Clock Period	75	—	—	ns	T <sub>cy</sub> = 75 ns, AD1CON3 in default state
AD51	t <sub>RC</sub>	ADC Internal RC Oscillator Period	—	250	—	ns	
<b>Conversion Rate</b>							
AD55	t <sub>CONV</sub>	Conversion Time	—	12	—	TAD	
AD56	FCNV	Throughput Rate	—	—	500	ksps	AV <sub>DD</sub> > 2.7V
AD57	t <sub>SAMP</sub>	Sample Time	—	1	—	TAD	
<b>Clock Parameters</b>							
AD61	t <sub>PSS</sub>	Sample Start Delay from Setting Sample Bit (SAMP)	2	—	3	TAD	
AD132	TACQ	Acquisition Time	—	—	750	ns	
AD135	T <sub>SWC</sub>	Switching Time from Convert to Sample	—	—	—	—	
AD137	T <sub>DIS</sub>	Discharge Time	0.5	—	—	TAD	
		A/D Stabilization Time (from setting ADON to setting SAMP)	—	300	—	ns	

**Note 1:** Because the sample caps will eventually lose charge, clock rates below 10 kHz can affect linearity performance, especially at elevated temperatures.

# PIC24FJ256GA110 FAMILY

**FIGURE 28-7: RESET, WATCHDOG TIMER, OSCILLATOR START-UP TIMER AND POWER-UP TIMER TIMING CHARACTERISTICS**



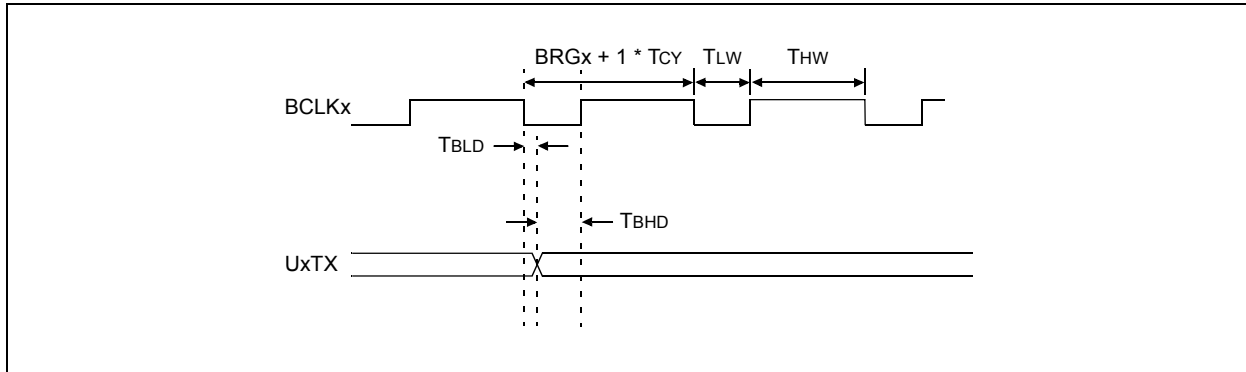
**TABLE 28-20: RESET, WATCHDOG TIMER, OSCILLATOR START-UP TIMER, POWER-UP TIMER AND BROWN-OUT RESET TIMING REQUIREMENTS**

AC CHARACTERISTICS			Standard Operating Conditions: 2.0V to 3.6V (unless otherwise stated) Operating temperature $-40^{\circ}\text{C} \leq T_A \leq +85^{\circ}\text{C}$ for Industrial				
Param No.	Symbol	Characteristic	Min	Typ <sup>(1)</sup>	Max	Units	Conditions
SY10	TmCL	MCLR Pulse Width (low)	2	—	—	$\mu\text{s}$	
SY11	TPWRT	Power-up Timer Period	—	64	—	ms	
SY12	TPOR	Power-on Reset Delay	1	5	10	$\mu\text{s}$	
SY13	TIOZ	I/O High-Impedance from MCLR Low or Watchdog Timer Reset	—	—	100	ns	
SY20	TWDT	Watchdog Timer Time-out Period	0.85	1.0	1.15	ms	1:32 prescaler
			3.4	4.0	4.6	ms	1:128 prescaler
SY25	TBOR	Brown-out Reset Pulse Width	1	—	—	$\mu\text{s}$	$V_{DD} \leq V_{BOR}$ , voltage regulator disabled

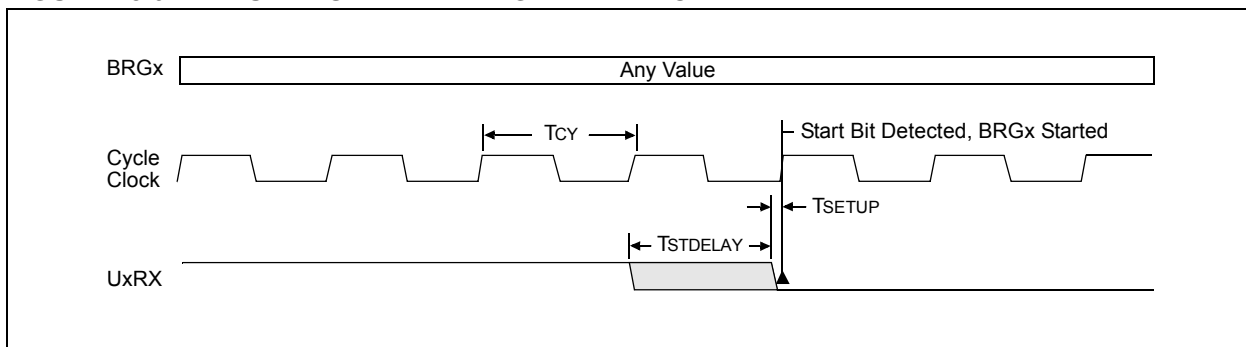
**Note 1:** Data in "Typ" column are at 3.3V, +25°C unless otherwise stated.

# PIC24FJ256GA110 FAMILY

**FIGURE 28-8: UART BAUD RATE GENERATOR OUTPUT TIMING**



**FIGURE 28-9: UART START BIT EDGE DETECTION**

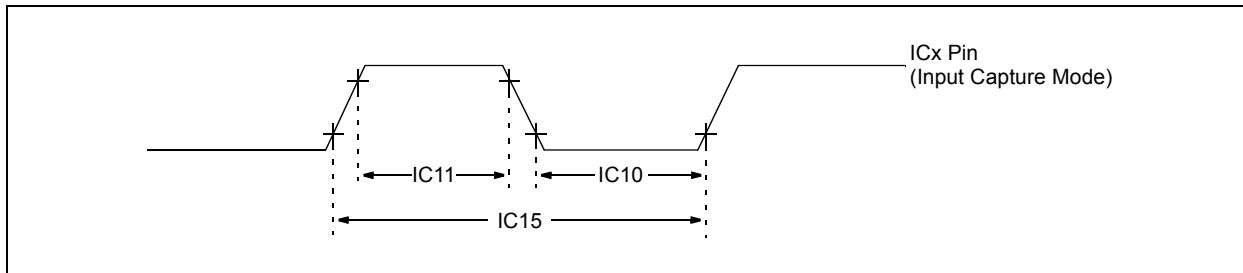


**TABLE 28-21: UART SPECIFICATIONS**

AC CHARACTERISTICS		Standard Operating Conditions: 2.0V to 3.6V (unless otherwise stated) Operating temperature $-40^{\circ}\text{C} \leq T_A \leq +85^{\circ}\text{C}$ for Industrial			
Symbol	Characteristics	Min	Typ	Max	Units
TLW	BCLKx High Time	20	$T_{cy}/2$	—	ns
THW	BCLKx Low Time	20	$(T_{cy} * BRGx) + T_{cy}/2$	—	ns
TBLD	BCLKx Falling Edge Delay from UxTX	-50	—	50	ns
TBHD	BCLKx Rising Edge Delay from UxTX	$T_{cy}/2 - 50$	—	$T_{cy}/2 + 50$	ns
TWAK	Min. Low on UxRX Line to Cause Wake-up	—	1	—	ms
TCTS	Min. Low on UxCTS Line to Start Transmission	$T_{cy}$	—	—	ns
TSETUP	Start Bit Falling Edge to System Clock Rising Edge Setup Time	3	—	—	ns
TSTDELAY	Maximum Delay in the Detection of the Start Bit Falling Edge	—	—	$T_{cy} + T_{SETUP}$	ns

# PIC24FJ256GA110 FAMILY

**FIGURE 28-10: INPUT CAPTURE TIMINGS**

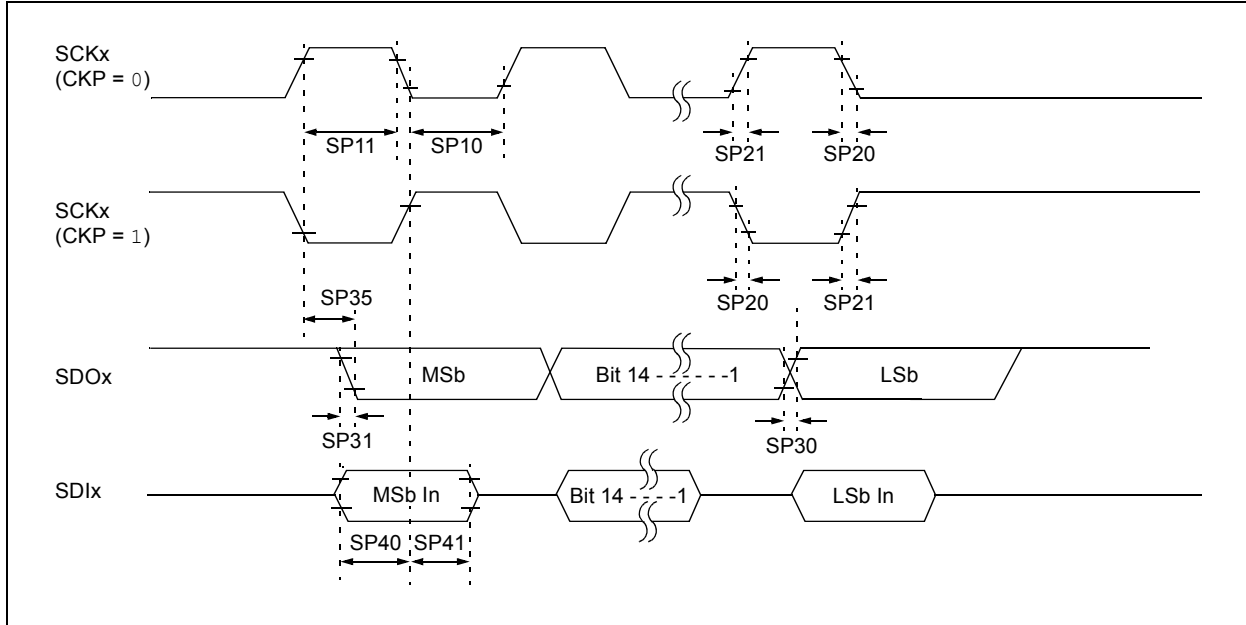


**TABLE 28-22: INPUT CAPTURE**

AC CHARACTERISTICS				Standard Operating Conditions: 2.0V to 3.6V (unless otherwise stated) Operating temperature $-40^{\circ}\text{C} \leq T_A \leq +85^{\circ}\text{C}$ for Industrial			
Param. No.	Symbol	Characteristic		Min	Max	Units	Conditions
IC10	TccL	ICx Input Low Time – Synchronous Timer	No Prescaler	$T_{CY} + 20$	—	ns	Must also meet Parameter IC15
			With Prescaler	20	—	ns	
IC11	TccH	ICx Input Low Time – Synchronous Timer	No Prescaler	$T_{CY} + 20$	—	ns	Must also meet Parameter IC15
			With Prescaler	20	—	ns	
IC15	TccP	ICx Input Period – Synchronous Timer		$\frac{2 * T_{CY} + 40}{N}$	—	ns	N = Prescale value (1, 4, 16)

# PIC24FJ256GA110 FAMILY

**FIGURE 28-11: SPIx MODULE MASTER MODE TIMING CHARACTERISTICS (CKE = 0)**



**TABLE 28-23: SPIx MASTER MODE TIMING REQUIREMENTS (CKE = 0)**

AC CHARACTERISTICS			Standard Operating Conditions: 2.0V to 3.6V (unless otherwise stated) Operating temperature $-40^{\circ}\text{C} \leq T_A \leq +85^{\circ}\text{C}$ for Industrial				
Param No.	Symbol	Characteristic	Min	Typ <sup>(1)</sup>	Max	Units	Conditions
SP10	TscL	SCKx Output Low Time <sup>(2)</sup>	$T_{CY}/2$	—	—	ns	
SP11	TscH	SCKx Output High Time <sup>(2)</sup>	$T_{CY}/2$	—	—	ns	
SP20	TscF	SCKx Output Fall Time <sup>(3)</sup>	—	10	25	ns	
SP21	TscR	SCKx Output Rise Time <sup>(3)</sup>	—	10	25	ns	
SP30	TdoF	SDOx Data Output Fall Time <sup>(3)</sup>	—	10	25	ns	
SP31	TdoR	SDOx Data Output Rise Time <sup>(3)</sup>	—	10	25	ns	
SP35	Tsch2doV, TscL2doV	SDOx Data Output Valid after SCKx Edge	—	—	30	ns	
SP40	TdiV2scH, TdiV2scL	Setup Time of SDIx Data Input to SCKx Edge	20	—	—	ns	
SP41	Tsch2diL, TscL2diL	Hold Time of SDIx Data Input to SCKx Edge	20	—	—	ns	

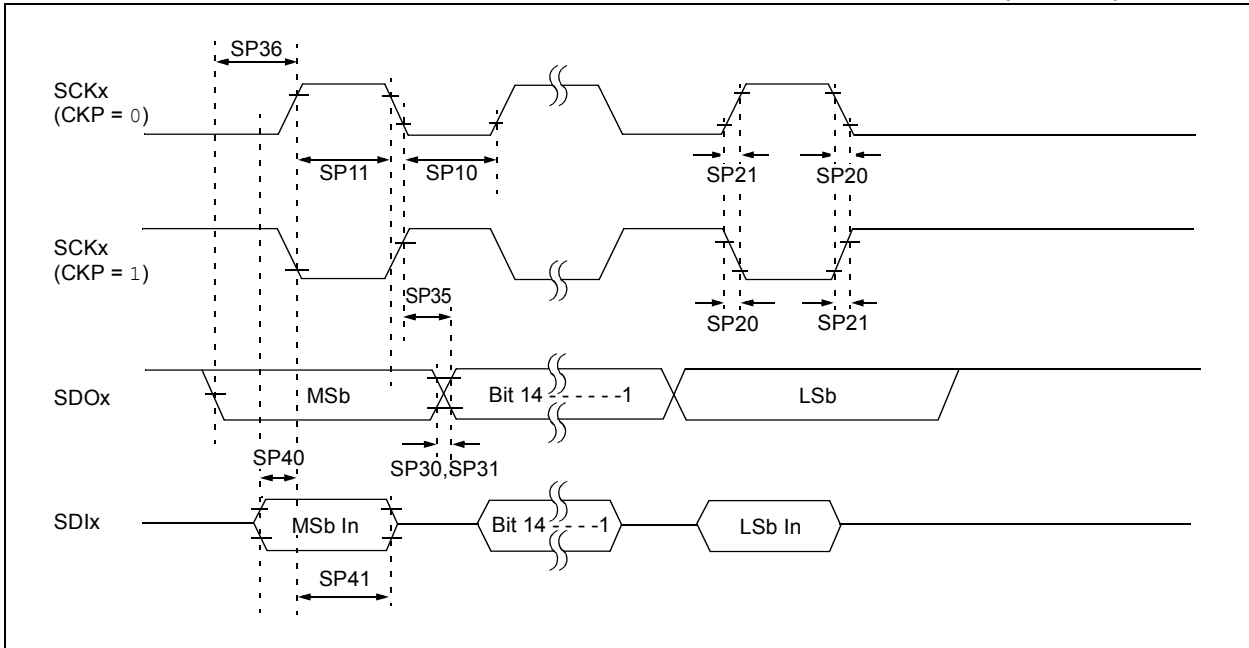
**Note 1:** Data in “Typ” column are at 3.3V, +25°C unless otherwise stated. Parameters are for design guidance only and are not tested.

**Note 2:** The minimum clock period for SCKx is 100 ns; therefore, the clock generated in Master mode must not violate this specification.

**Note 3:** Assumes 50 pF load on all SPIx pins.

# PIC24FJ256GA110 FAMILY

**FIGURE 28-12: SPIx MODULE MASTER MODE TIMING CHARACTERISTICS (CKE = 1)**



**TABLE 28-24: SPIx MODULE MASTER MODE TIMING REQUIREMENTS (CKE = 1)**

AC CHARACTERISTICS			Standard Operating Conditions: 2.0V to 3.6V (unless otherwise stated) Operating temperature $-40^{\circ}\text{C} \leq T_A \leq +85^{\circ}\text{C}$ for Industrial				
Param No.	Symbol	Characteristic	Min	Typ <sup>(1)</sup>	Max	Units	Conditions
SP10	TscL	SCKx Output Low Time <sup>(2)</sup>	$T_{CY}/2$	—	—	ns	
SP11	Tsch	SCKx Output High Time <sup>(2)</sup>	$T_{CY}/2$	—	—	ns	
SP20	TscF	SCKx Output Fall Time <sup>(3)</sup>	—	10	25	ns	
SP21	TscR	SCKx Output Rise Time <sup>(3)</sup>	—	10	25	ns	
SP30	TdoF	SDOx Data Output Fall Time <sup>(3)</sup>	—	10	25	ns	
SP31	TdoR	SDOx Data Output Rise Time <sup>(3)</sup>	—	10	25	ns	
SP35	Tsch2doV, TscL2doV	SDOx Data Output Valid after SCKx Edge	—	—	30	ns	
SP36	TdoV2sc, TdoV2scL	SDOx Data Output Setup to First SCKx Edge	30	—	—	ns	
SP40	TdiV2sch, TdiV2scL	Setup Time of SDIx Data Input to SCKx Edge	20	—	—	ns	
SP41	Tsch2diL, TscL2diL	Hold Time of SDIx Data Input to SCKx Edge	20	—	—	ns	

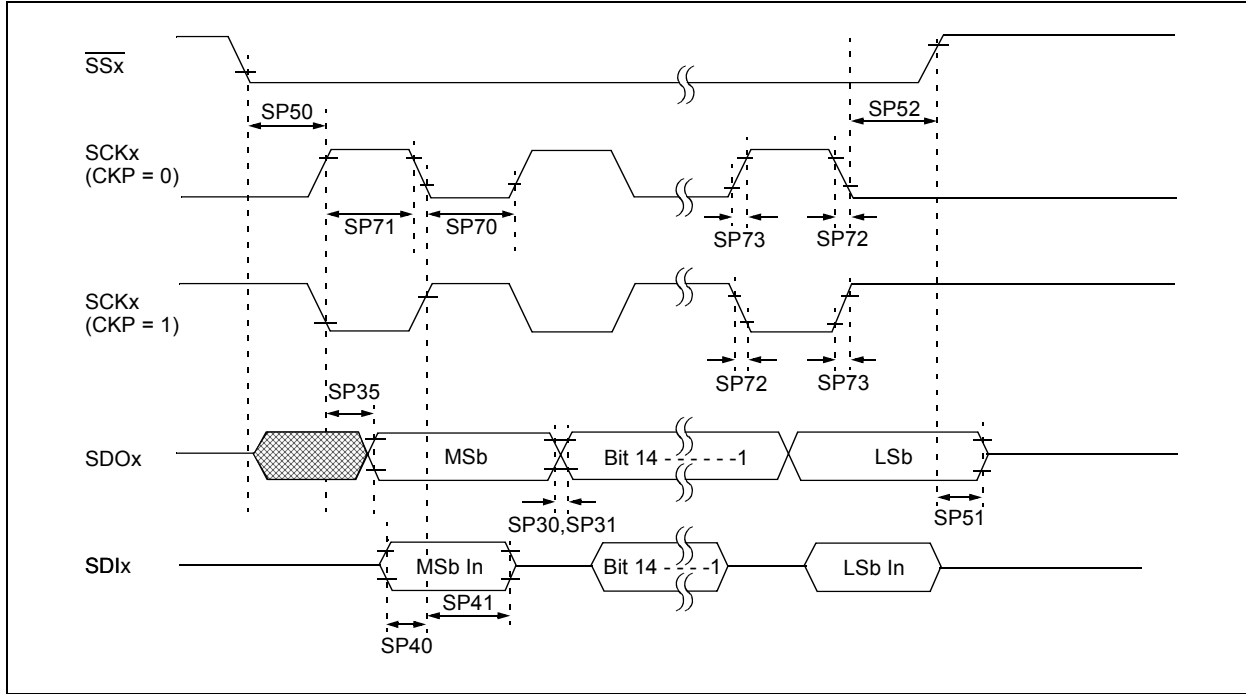
**Note 1:** Data in “Typ” column are at 3.3V, +25°C unless otherwise stated. Parameters are for design guidance only and are not tested.

**2:** The minimum clock period for SCKx is 100 ns. Therefore, the clock generated in Master mode must not violate this specification.

**3:** Assumes 50 pF load on all SPIx pins.

# PIC24FJ256GA110 FAMILY

**FIGURE 28-13: SPIx MODULE SLAVE MODE TIMING CHARACTERISTICS (CKE = 0)**



**TABLE 28-25: SPIx MODULE SLAVE MODE TIMING REQUIREMENTS (CKE = 0)**

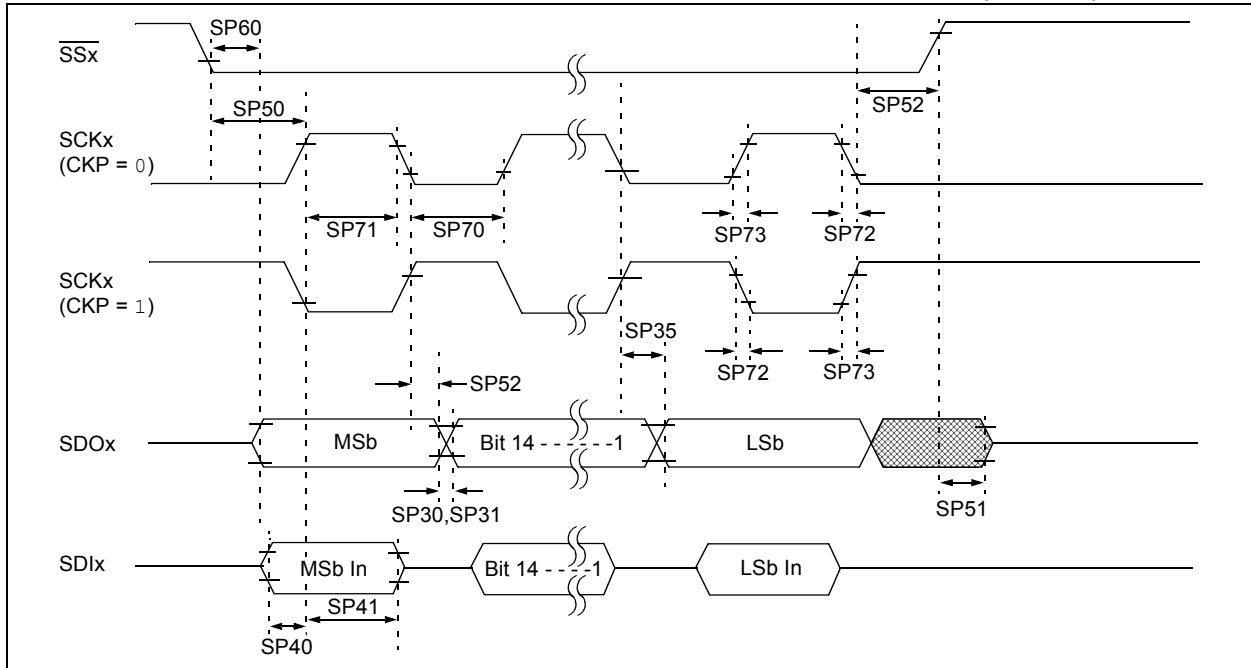
AC CHARACTERISTICS			Standard Operating Conditions: 2.0V to 3.6V (unless otherwise stated) Operating temperature $-40^{\circ}\text{C} \leq T_A \leq +85^{\circ}\text{C}$ for Industrial				
Param No.	Symbol	Characteristic	Min	Typ <sup>(1)</sup>	Max	Units	Conditions
SP70	TscL	SCKx Input Low Time	30	—	—	ns	
SP71	TscH	SCKx Input High Time	30	—	—	ns	
SP72	TscF	SCKx Input Fall Time <sup>(2)</sup>	—	10	25	ns	
SP73	TscR	SCKx Input Rise Time <sup>(2)</sup>	—	10	25	ns	
SP30	TdoF	SDOx Data Output Fall Time <sup>(2)</sup>	—	10	25	ns	
SP31	TdoR	SDOx Data Output Rise Time <sup>(2)</sup>	—	10	25	ns	
SP35	Tsch2doV, TscL2doV	SDOx Data Output Valid after SCKx Edge	—	—	30	ns	
SP40	TdiV2scH, TdiV2scL	Setup Time of SDIx Data Input to SCKx Edge	20	—	—	ns	
SP41	Tsch2diL, TscL2diL	Hold Time of SDIx Data Input to SCKx Edge	20	—	—	ns	
SP50	TssL2scH, TssL2scL	$\overline{\text{SSx}}$ to SCKx $\uparrow$ or SCKx Input	120	—	—	ns	
SP51	TssH2doZ	$\overline{\text{SSx}}$ $\uparrow$ to SDOx Output High-Impedance	10	—	50	ns	
SP52	Tsch2ssH TscL2ssH	$\overline{\text{SSx}}$ after SCKx Edge	$1.5 T_{cy} + 40$	—	—	ns	

**Note 1:** Data in “Typ” column are at 3.3V, +25°C unless otherwise stated. Parameters are for design guidance only and are not tested.

**2:** Assumes 50 pF load on all SPIx pins.

# PIC24FJ256GA110 FAMILY

**FIGURE 28-14: SPIx MODULE SLAVE MODE TIMING CHARACTERISTICS (CKE = 1)**



**TABLE 28-26: SPIx MODULE SLAVE MODE TIMING REQUIREMENTS (CKE = 1)**

AC CHARACTERISTICS			Standard Operating Conditions: 2.0V to 3.6V (unless otherwise stated) Operating temperature $-40^{\circ}\text{C} \leq T_A \leq +85^{\circ}\text{C}$ for Industrial				
Param No.	Symbol	Characteristic	Min	Typ <sup>(1)</sup>	Max	Units	Conditions
SP70	TscL	SCKx Input Low Time	30	—	—	ns	
SP71	Tsch	SCKx Input High Time	30	—	—	ns	
SP72	TscF	SCKx Input Fall Time <sup>(2)</sup>	—	10	25	ns	
SP73	TscR	SCKx Input Rise Time <sup>(2)</sup>	—	10	25	ns	
SP30	TdoF	SDOx Data Output Fall Time <sup>(2)</sup>	—	10	25	ns	
SP31	TdoR	SDOx Data Output Rise Time <sup>(2)</sup>	—	10	25	ns	
SP35	Tsch2doV, TscL2doV	SDOx Data Output Valid after SCKx Edge	—	—	30	ns	
SP40	TdiV2sch, TdiV2scl	Setup Time of SDIx Data Input to SCKx Edge	20	—	—	ns	
SP41	Tsch2diL, TscL2diL	Hold Time of SDIx Data Input to SCKx Edge	20	—	—	ns	
SP50	Tssl2sch, Tssl2scl	$\overline{\text{SSx}} \downarrow$ to SCKx $\downarrow$ or SCKx $\uparrow$ Input	120	—	—	ns	
SP51	TssH2doZ	$\overline{\text{SSx}} \uparrow$ to SDOx Output High-Impedance <sup>(3)</sup>	10	—	50	ns	
SP52	Tsch2ssH, TscL2ssH	$\overline{\text{SSx}} \uparrow$ after SCKx Edge	$1.5 T_{CY} + 40$	—	—	ns	
SP60	Tssl2doV	SDOx Data Output Valid after $\overline{\text{SSx}}$ Edge	—	—	50	ns	

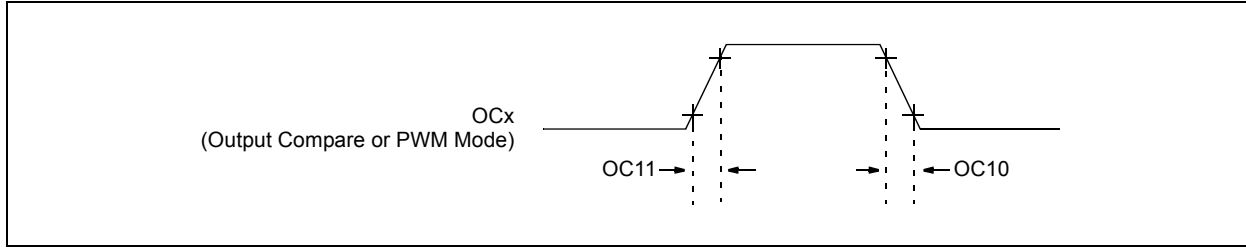
**Note 1:** Data in "Typ" column are at 3.3V, +25°C unless otherwise stated. Parameters are for design guidance only and are not tested.

**2:** The minimum clock period for SCKx is 100 ns. Therefore, the clock generated in Master mode must not violate this specification.

**3:** Assumes 50 pF load on all SPIx pins.

# PIC24FJ256GA110 FAMILY

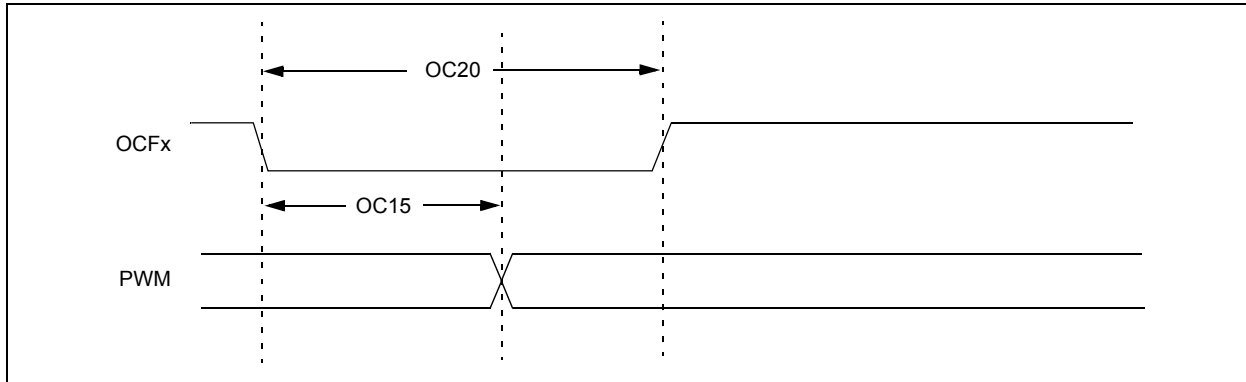
**FIGURE 28-15: OUTPUT COMPARE TIMINGS**



**TABLE 28-27: OUTPUT COMPARE**

Param. No.	Symbol	Characteristic	Min	Max	Unit	Condition
OC11	TccR	OC1 Output Rise Time	—	10	ns	
			—	—	ns	
OC10	TccF	OC1 Output Fall Time	—	10	ns	
			—	—	ns	

**FIGURE 28-16: PWM MODULE TIMING REQUIREMENTS**



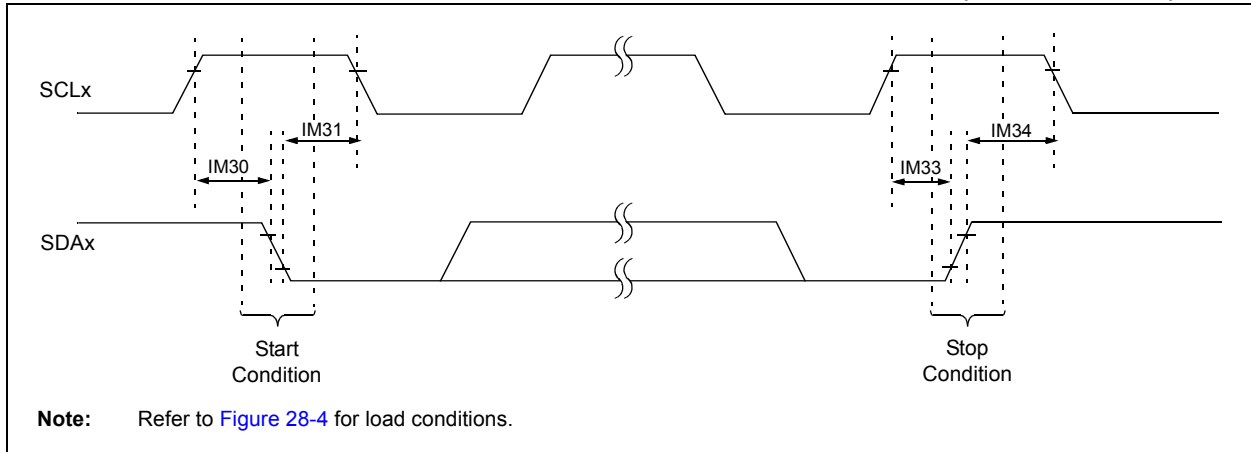
**TABLE 28-28: PWM TIMING REQUIREMENTS**

AC CHARACTERISTICS			Standard Operating Conditions: 2.0V to 3.6V (unless otherwise stated) Operating temperature $-40^{\circ}\text{C} \leq T_A \leq +85^{\circ}\text{C}$ for Industrial				
Param. No.	Symbol	Characteristic	Min	Typ <sup>(1)</sup>	Max	Unit	Condition
OC15	TFD	Fault Input to PWM I/O Change	—	—	25	ns	$V_{DD} = 3.0\text{V}$ , $-40^{\circ}\text{C}$ to $+85^{\circ}\text{C}$
OC20	TFH	Fault Input Pulse Width	50	—	—	ns	$V_{DD} = 3.0\text{V}$ , $-40^{\circ}\text{C}$ to $+85^{\circ}\text{C}$

**Note 1:** Data in "Typ" column are at 3.3V, +25°C unless otherwise stated. These parameters are for design guidance only and are not tested.

# PIC24FJ256GA110 FAMILY

**FIGURE 28-17: I<sup>2</sup>C BUS START/STOP BITS TIMING CHARACTERISTICS (MASTER MODE)**



**TABLE 28-29: I<sup>2</sup>C BUS START/STOP BIT TIMING REQUIREMENTS (MASTER MODE)**

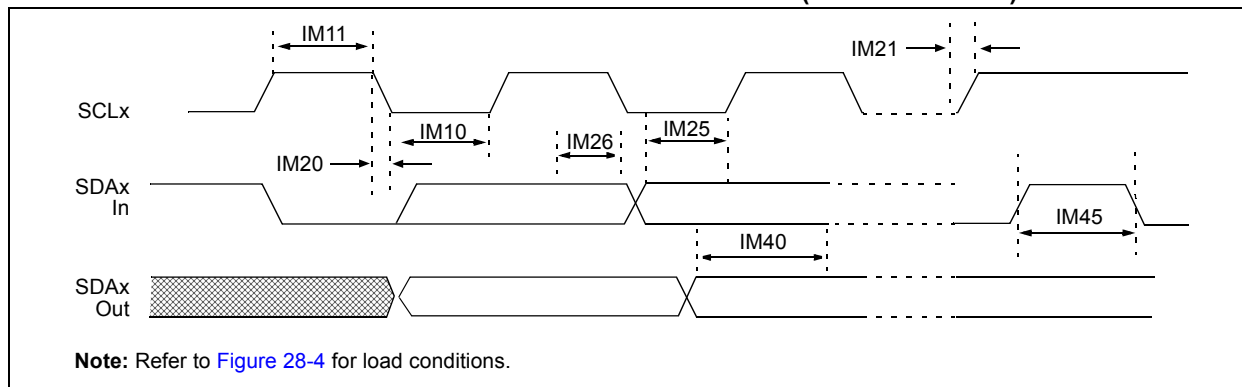
AC CHARACTERISTICS				Standard Operating Conditions: 2.0V to 3.6V (unless otherwise stated) Operating temperature $-40^{\circ}\text{C} \leq T_A \leq +85^{\circ}\text{C}$ (Industrial)			
Param No.	Symbol	Characteristic		Min <sup>(1)</sup>	Max	Units	Conditions
IM30	TSU:STA	Start Condition Setup Time	100 kHz mode	$T_{CY}/2$ (BRG + 1)	—	$\mu\text{s}$	Only relevant for Repeated Start condition
			400 kHz mode	$T_{CY}/2$ (BRG + 1)	—	$\mu\text{s}$	
			1 MHz mode <sup>(2)</sup>	$T_{CY}/2$ (BRG + 1)	—	$\mu\text{s}$	
IM31	THD:STA	Start Condition Hold Time	100 kHz mode	$T_{CY}/2$ (BRG + 1)	—	$\mu\text{s}$	After this period, the first clock pulse is generated
			400 kHz mode	$T_{CY}/2$ (BRG + 1)	—	$\mu\text{s}$	
			1 MHz mode <sup>(2)</sup>	$T_{CY}/2$ (BRG + 1)	—	$\mu\text{s}$	
IM33	TSU:STO	Stop Condition Setup Time	100 kHz mode	$T_{CY}/2$ (BRG + 1)	—	$\mu\text{s}$	
			400 kHz mode	$T_{CY}/2$ (BRG + 1)	—	$\mu\text{s}$	
			1 MHz mode <sup>(2)</sup>	$T_{CY}/2$ (BRG + 1)	—	$\mu\text{s}$	
IM34	THD:STO	Stop Condition Hold Time	100 kHz mode	$T_{CY}/2$ (BRG + 1)	—	ns	
			400 kHz mode	$T_{CY}/2$ (BRG + 1)	—	ns	
			1 MHz mode <sup>(2)</sup>	$T_{CY}/2$ (BRG + 1)	—	ns	

**Note 1:** BRG is the value of the I<sup>2</sup>C Baud Rate Generator. Refer to [Section 16.3 “Setting Baud Rate When Operating as a Bus Master”](#) for details.

**Note 2:** Maximum pin capacitance = 10 pF for all I<sup>2</sup>C pins (for 1 MHz mode only).

# PIC24FJ256GA110 FAMILY

**FIGURE 28-18: I<sup>2</sup>C BUS DATA TIMING CHARACTERISTICS (MASTER MODE)**



**TABLE 28-30: I<sup>2</sup>C BUS DATA TIMING REQUIREMENTS (MASTER MODE)**

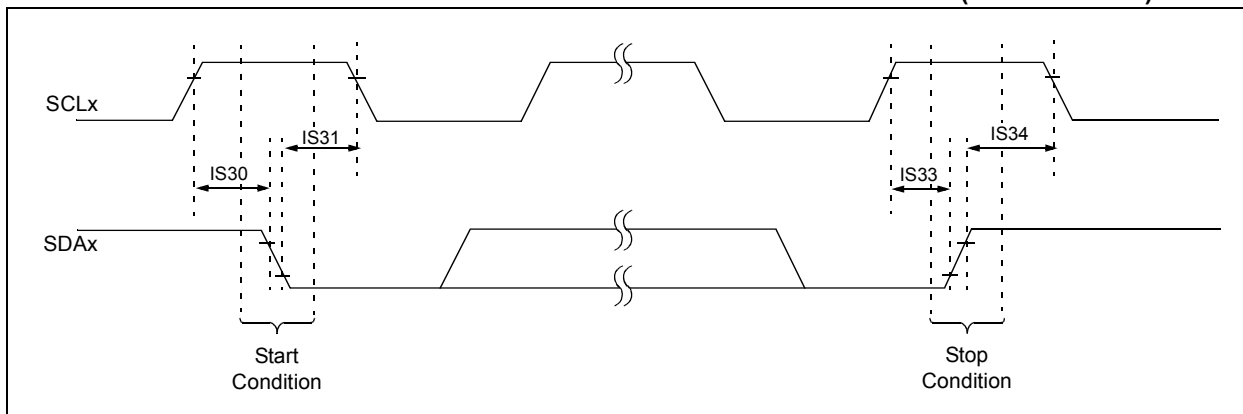
AC CHARACTERISTICS				Standard Operating Conditions: 2.0V to 3.6V (unless otherwise stated) Operating temperature $-40^{\circ}\text{C} \leq T_A \leq +85^{\circ}\text{C}$ (Industrial)			
Param No.	Symbol	Characteristic		Min <sup>(1)</sup>	Max	Units	Conditions
IM10	TLO:SCL	Clock Low Time	100 kHz mode	$T_{CY}/2$ (BRG + 1)	—	$\mu\text{s}$	
			400 kHz mode	$T_{CY}/2$ (BRG + 1)	—	$\mu\text{s}$	
			1 MHz mode <sup>(2)</sup>	$T_{CY}/2$ (BRG + 1)	—	$\mu\text{s}$	
IM11	THI:SCL	Clock High Time	100 kHz mode	$T_{CY}/2$ (BRG + 1)	—	$\mu\text{s}$	
			400 kHz mode	$T_{CY}/2$ (BRG + 1)	—	$\mu\text{s}$	
			1 MHz mode <sup>(2)</sup>	$T_{CY}/2$ (BRG + 1)	—	$\mu\text{s}$	
IM20	TF:SCL	SDAx and SCLx Fall Time	100 kHz mode	—	300	ns	CB is specified to be from 10 to 400 pF
			400 kHz mode	$20 + 0.1 \text{ CB}$	300	ns	
			1 MHz mode <sup>(2)</sup>	—	100	ns	
IM21	TR:SCL	SDAx and SCLx Rise Time	100 kHz mode	—	1000	ns	CB is specified to be from 10 to 400 pF
			400 kHz mode	$20 + 0.1 \text{ CB}$	300	ns	
			1 MHz mode <sup>(2)</sup>	—	300	ns	
IM25	TSU:DAT	Data Input Setup Time	100 kHz mode	250	—	ns	
			400 kHz mode	100	—	ns	
			1 MHz mode <sup>(2)</sup>	—	—	ns	
IM26	THD:DAT	Data Input Hold Time	100 kHz mode	0	—	ns	
			400 kHz mode	0	0.9	$\mu\text{s}$	
			1 MHz mode <sup>(2)</sup>	—	—	ns	
IM40	TAA:SCL	Output Valid from Clock	100 kHz mode	—	3500	ns	
			400 kHz mode	—	1000	ns	
			1 MHz mode <sup>(2)</sup>	—	—	ns	
IM45	TBF:SDA	Bus Free Time	100 kHz mode	4.7	—	$\mu\text{s}$	Time the bus must be free before a new transmission can start
			400 kHz mode	1.3	—	$\mu\text{s}$	
			1 MHz mode <sup>(2)</sup>	—	—	$\mu\text{s}$	
IM50	CB	Bus Capacitive Loading	—	400	pF		

**Note 1:** BRG is the value of the I<sup>2</sup>C Baud Rate Generator. Refer to [Section 16.3 “Setting Baud Rate When Operating as a Bus Master”](#) for details.

**2:** Maximum pin capacitance = 10 pF for all I<sup>2</sup>C pins (for 1 MHz mode only).

# PIC24FJ256GA110 FAMILY

**FIGURE 28-19: I<sup>2</sup>C BUS START/STOP BITS TIMING CHARACTERISTICS (SLAVE MODE)**



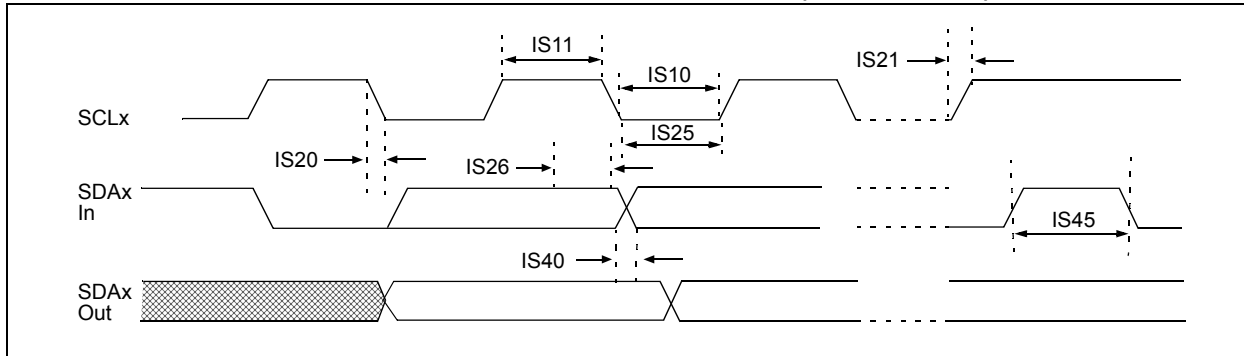
**TABLE 28-31: I<sup>2</sup>C BUS START/STOP BIT TIMING REQUIREMENTS (SLAVE MODE)**

AC CHARACTERISTICS				Standard Operating Conditions: 2.0V to 3.6V (unless otherwise stated) Operating temperature $-40^{\circ}\text{C} \leq T_A \leq +85^{\circ}\text{C}$ (Industrial)			
Param No.	Symbol	Characteristic		Min	Max	Units	Conditions
IS30	TSU:STA	Start Condition Setup Time	100 kHz mode	4.7	—	$\mu\text{s}$	Only relevant for Repeated Start condition
			400 kHz mode	0.6	—	$\mu\text{s}$	
			1 MHz mode <sup>(1)</sup>	0.25	—	$\mu\text{s}$	
IS31	THD:STA	Start Condition Hold Time	100 kHz mode	4.0	—	$\mu\text{s}$	After this period, the first clock pulse is generated
			400 kHz mode	0.6	—	$\mu\text{s}$	
			1 MHz mode <sup>(1)</sup>	0.25	—	$\mu\text{s}$	
IS33	TSU:STO	Stop Condition Setup Time	100 kHz mode	4.7	—	$\mu\text{s}$	—
			400 kHz mode	0.6	—	$\mu\text{s}$	
			1 MHz mode <sup>(1)</sup>	0.6	—	$\mu\text{s}$	
IS34	THD:STO	Stop Condition Hold Time	100 kHz mode	4000	—	ns	—
			400 kHz mode	600	—	ns	
			1 MHz mode <sup>(1)</sup>	250	—	ns	

**Note 1:** Maximum pin capacitance = 10 pF for all I<sup>2</sup>C pins (for 1 MHz mode only).

# PIC24FJ256GA110 FAMILY

**FIGURE 28-20: I<sup>2</sup>C BUS DATA TIMING CHARACTERISTICS (SLAVE MODE)**



**TABLE 28-32: I<sup>2</sup>C BUS DATA TIMING REQUIREMENTS (SLAVE MODE)**

AC CHARACTERISTICS				Standard Operating Conditions: 2.0V to 3.6V (unless otherwise stated) Operating temperature -40°C ≤ TA ≤ +85°C (Industrial)			
Param No.	Symbol	Characteristic		Min	Max	Units	Conditions
IS10	TLO:SCL	Clock Low Time	100 kHz mode	4.7	—	μs	Device must operate at a minimum of 1.5 MHz
			400 kHz mode	1.3	—	μs	Device must operate at a minimum of 10 MHz
			1 MHz mode <sup>(1)</sup>	0.5	—	μs	
IS11	THI:SCL	Clock High Time	100 kHz mode	4.0	—	μs	Device must operate at a minimum of 1.5 MHz
			400 kHz mode	0.6	—	μs	Device must operate at a minimum of 10 MHz
			1 MHz mode <sup>(1)</sup>	0.5	—	μs	
IS20	TF:SCL	SDAx and SCLx Fall Time	100 kHz mode	—	300	ns	Cb is specified to be from 10 to 400 pF
			400 kHz mode	20 + 0.1 Cb	300	ns	
			1 MHz mode <sup>(1)</sup>	—	100	ns	
IS21	TR:SCL	SDAx and SCLx Rise Time	100 kHz mode	—	1000	ns	Cb is specified to be from 10 to 400 pF
			400 kHz mode	20 + 0.1 Cb	300	ns	
			1 MHz mode <sup>(1)</sup>	—	300	ns	
IS25	TSU:DAT	Data Input Setup Time	100 kHz mode	250	—	ns	
			400 kHz mode	100	—	ns	
			1 MHz mode <sup>(1)</sup>	100	—	ns	
IS26	THD:DAT	Data Input Hold Time	100 kHz mode	0	—	ns	
			400 kHz mode	0	0.9	μs	
			1 MHz mode <sup>(1)</sup>	0	0.3	μs	
IS40	TAA:SCL	Output Valid From Clock	100 kHz mode	0	3500	ns	
			400 kHz mode	0	1000	ns	
			1 MHz mode <sup>(1)</sup>	0	350	ns	
IS45	TBF:SDA	Bus Free Time	100 kHz mode	4.7	—	μs	Time the bus must be free before a new transmission can start
			400 kHz mode	1.3	—	μs	
			1 MHz mode <sup>(1)</sup>	0.5	—	μs	
IS50	Cb	Bus Capacitive Loading		—	400	pF	

**Note 1:** Maximum pin capacitance = 10 pF for all I<sup>2</sup>C pins (for 1 MHz mode only).

# PIC24FJ256GA110 FAMILY

FIGURE 28-21: PARALLEL SLAVE PORT TIMING

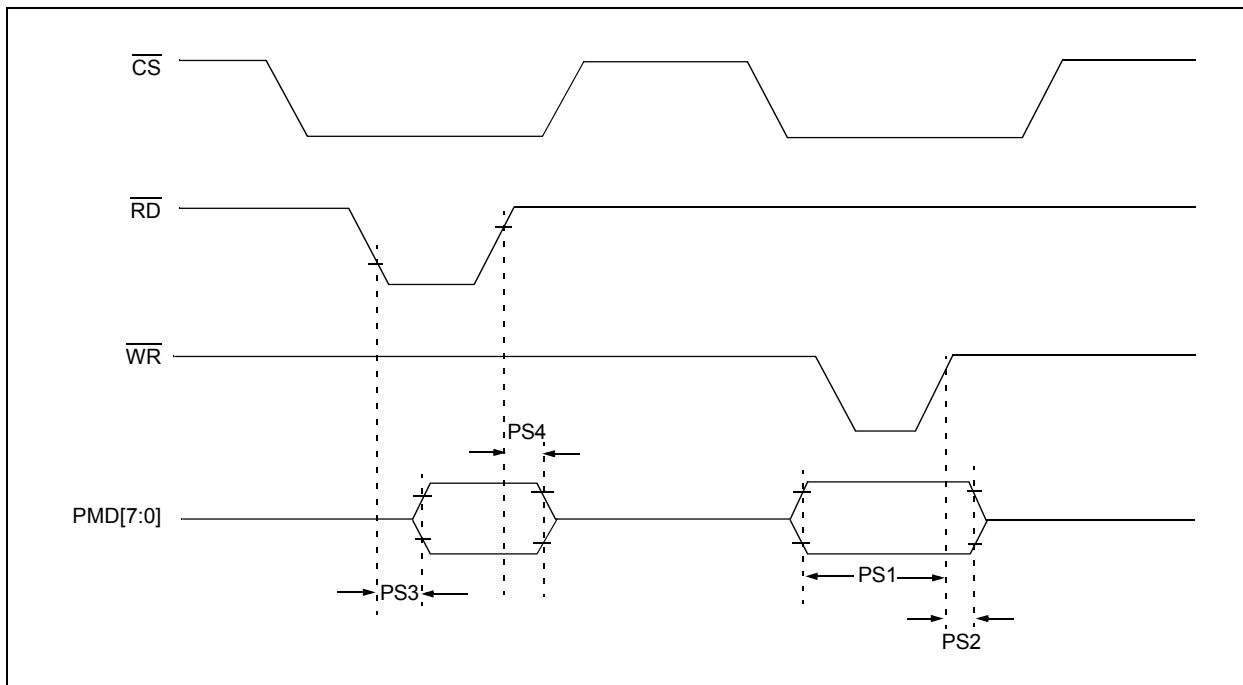
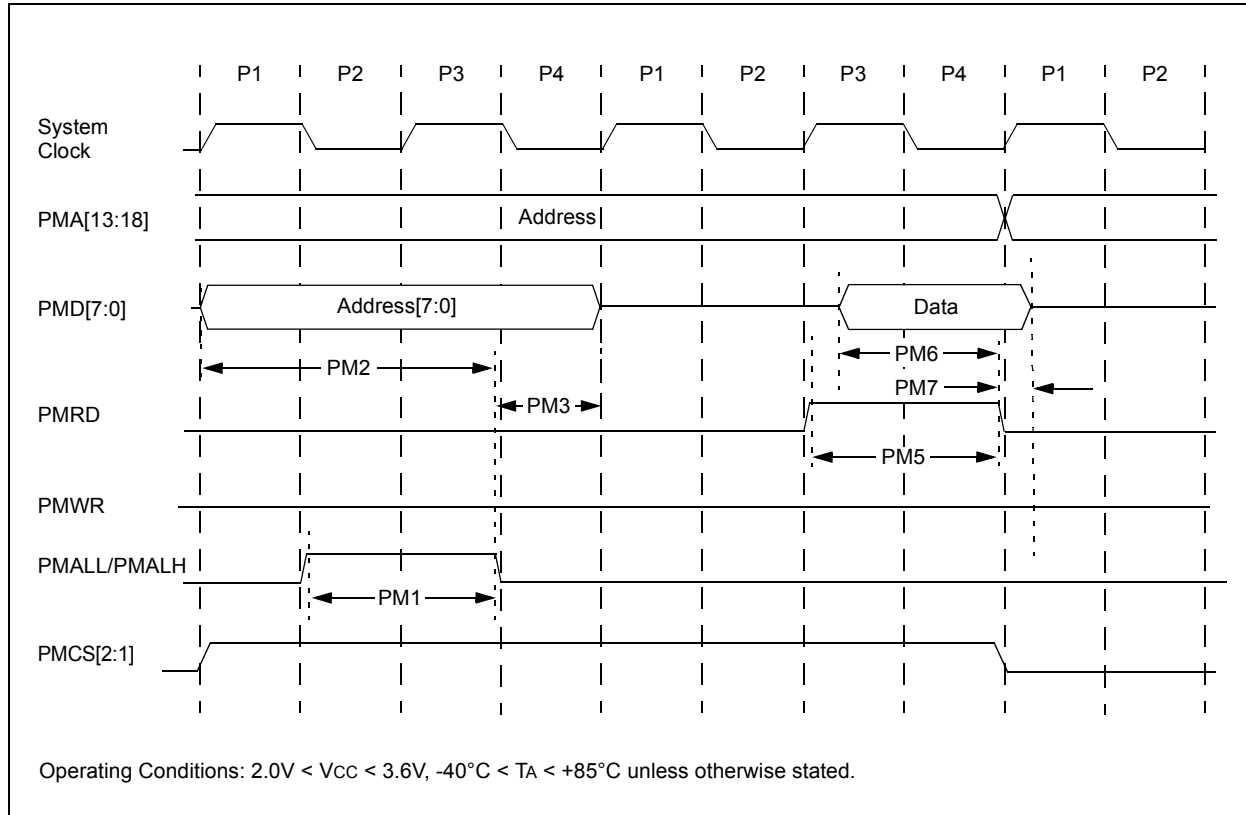


TABLE 28-33: PARALLEL SLAVE PORT REQUIREMENTS

AC CHARACTERISTICS			Standard Operating Conditions: 2.0V to 3.6V (unless otherwise stated) Operating temperature $-40^{\circ}\text{C} \leq T_A \leq +85^{\circ}\text{C}$ for Industrial				
Param. No.	Symbol	Characteristic	Min	Typ	Max	Units	Conditions
PS1	TdtV2wrH	Data In Valid before $\overline{WR}$ or $\overline{CS}$ Inactive (setup time)	20	—	—	ns	
PS2	TwrH2dtI	$\overline{WR}$ or $\overline{CS}$ Inactive to Data-In Invalid (hold time)	20	—	—	ns	
PS3	TrdL2dtV	$\overline{RD}$ and $\overline{CS}$ Active to Data-Out Valid	—	—	80	ns	
PS4	TrdH2dtI	$\overline{RD}$ Active or $\overline{CS}$ Inactive to Data-Out Invalid	10	—	30	ns	

# PIC24FJ256GA110 FAMILY

**FIGURE 28-22: PARALLEL MASTER PORT READ TIMING DIAGRAM**



**TABLE 28-34: PARALLEL MASTER PORT READ TIMING REQUIREMENTS**

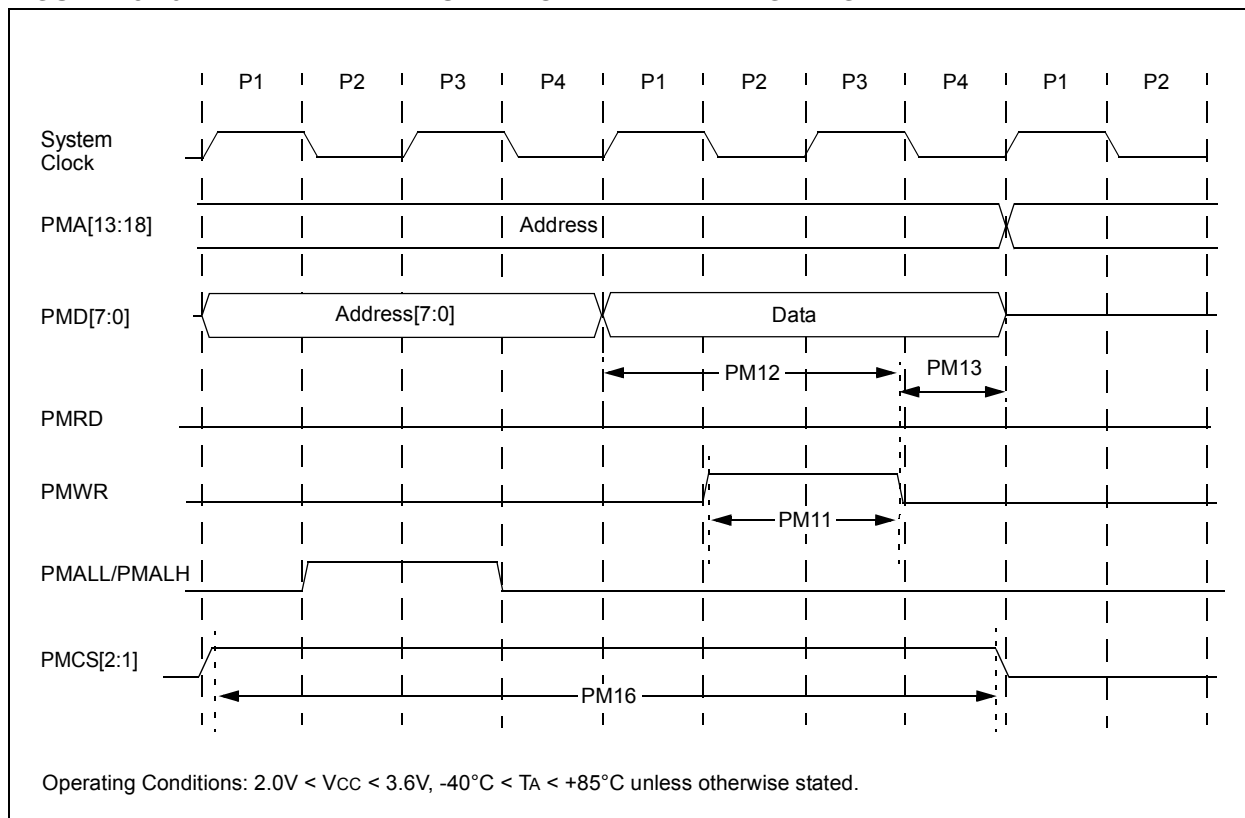
AC CHARACTERISTICS			Standard Operating Conditions: 2.0V to 3.6V (unless otherwise stated) Operating temperature -40°C ≤ Ta ≤ +85°C for Industrial				
Param. No	Symbol	Characteristics <sup>(1)</sup>	Min	Typ	Max	Units	Conditions
PM1		PMALL/PMALH Pulse Width	—	0.5 Tcy	—	ns	
PM2		Address Out Valid to PMALL/PMALH Invalid (address setup time) <sup>(2)</sup>	—	0.75 Tcy	—	ns	
PM3		PMALL/PMALH Invalid to Address Out Invalid (address hold time)	—	0.25 Tcy	—	ns	
PM5		PMRD Pulse Width	—	0.5 Tcy	—	ns	
PM6		Data In to PMRD or PMENB Inactive State	150	—	—	ns	
PM7		PMRD or PMENB Inactive to Data In Invalid (data hold time)	—	—	5	ns	

**Note 1:** Wait states are disabled for all cases.

**2:** The setup time for the LSB and the MSB of the address are not the same; the setup time for the LSB is 0.5 Tcy and for the MSB is 0.75 Tcy.

# PIC24FJ256GA110 FAMILY

**FIGURE 28-23: PARALLEL MASTER PORT WRITE TIMING DIAGRAM**



**TABLE 28-35: PARALLEL MASTER PORT WRITE TIMING REQUIREMENTS**

AC CHARACTERISTICS			Standard Operating Conditions: 2.0V to 3.6V (unless otherwise stated) Operating temperature -40°C ≤ Ta ≤ +85°C for Industrial				
Param. No	Symbol	Characteristics <sup>(1)</sup>	Min	Typ	Max	Units	Conditions
PM11		PMWR Pulse Width	—	0.5 Tcy	—	ns	
PM12		Data Out Valid before PMWR or PMENB goes Inactive (data setup time)	—	0.75 Tcy	—	ns	
PM13		PMWR or PMEMB Invalid to Data Out Invalid (data hold time)	—	0.25 Tcy	—	ns	
PM16		PMCSx Pulse Width	Tcy - 5	—	—	ns	

**Note 1:** Wait states disabled for all cases.

# PIC24FJ256GA110 FAMILY

**TABLE 28-36: COMPARATOR SPECIFICATIONS**

AC CHARACTERISTICS			Standard Operating Conditions: 2.0V to 3.6V (unless otherwise stated) Operating temperature $-40^{\circ}\text{C} \leq T_A \leq +85^{\circ}\text{C}$ for Industrial				
Param No.	Symbol	Characteristic	Min	Typ	Max	Units	Comments
D300	VIOFF	Input Offset Voltage*	—	10	30	mV	
D301	VICM	Input Common-Mode Voltage*	0	—	VDD	V	
D302	CMRR	Common-Mode Rejection Ratio*	55	—	—	dB	
300	TRESP	Response Time*(1)	—	150	400	ns	
301	TMC2OV	Comparator Mode Change to Output Valid*				$\mu\text{s}$	

\* Parameters are characterized but not tested.

**Note 1:** Response time measured with one comparator input at  $(V_{DD} - 1.5)/2$ , while the other input transitions from VSS to VDD.

**TABLE 28-37: COMPARATOR VOLTAGE REFERENCE SPECIFICATIONS**

AC CHARACTERISTICS			Standard Operating Conditions: 2.0V to 3.6V (unless otherwise stated) Operating temperature $-40^{\circ}\text{C} \leq T_A \leq +85^{\circ}\text{C}$ for Industrial				
Param No.	Symbol	Characteristic	Min	Typ	Max	Units	Comments
VRD310	CVRES	Resolution	$V_{DD}/24$	—	$V_{DD}/32$	LSb	
VRD311	CVRAA	Absolute Accuracy	—	—	$AV_{dd} - 1.5$	LSb	
VRD312	CVRUR	Unit Resistor Value (R)	—	2k	—	$\Omega$	
VR310	TSET	Setting Time*(1)	—	—	10	$\mu\text{s}$	

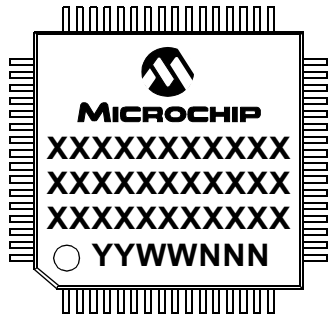
**Note 1:** Settling time is measured while CVRR = 1 and the CVR<3:0> bits transition from '0000' to '1111'.

# PIC24FJ256GA110 FAMILY

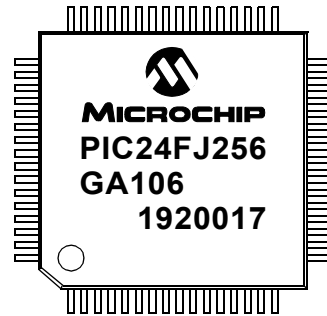
## 29.0 PACKAGING INFORMATION

### 29.1 Package Marking Information

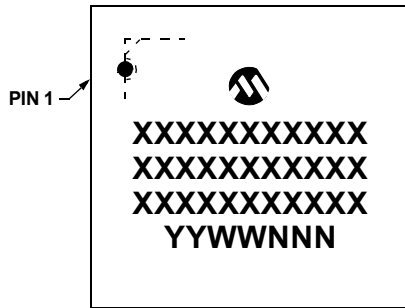
64-Lead TQFP (10x10x1 mm)



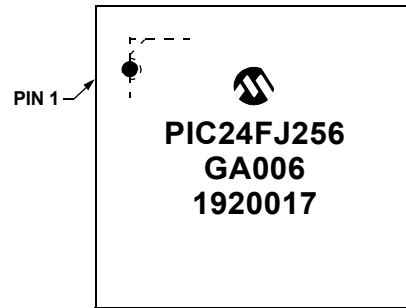
Example



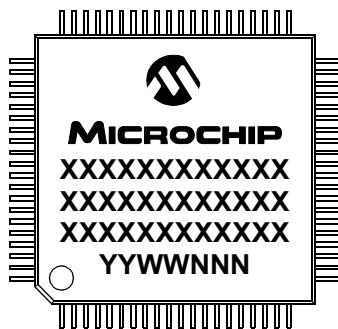
64-Lead QFN (9x9x0.9 mm)



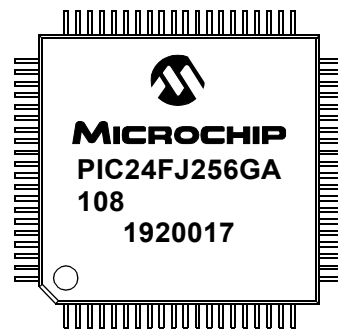
Example



80-Lead TQFP (12x12x1 mm)



Example



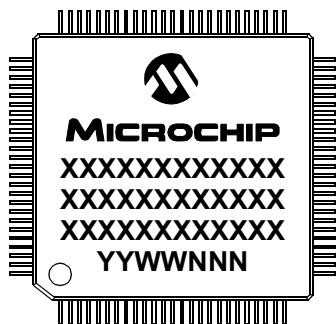
<b>Legend:</b>	XX...X	Customer-specific information
	Y	Year code (last digit of calendar year)
	YY	Year code (last 2 digits of calendar year)
	WW	Week code (week of January 1 is week '01')
	NNN	Alphanumeric traceability code

**Note:** In the event the full Microchip part number cannot be marked on one line, it will be carried over to the next line, thus limiting the number of available characters for customer-specific information.

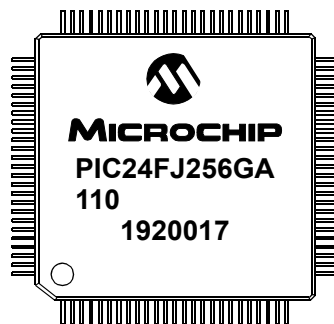
# PIC24FJ256GA110 FAMILY

---

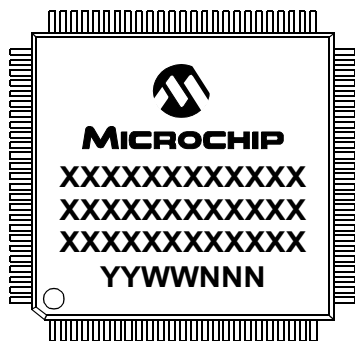
100-Lead TQFP (12x12x1 mm)



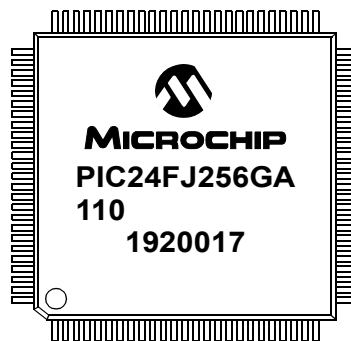
Example



100-Lead TQFP (14x14x1 mm)



Example



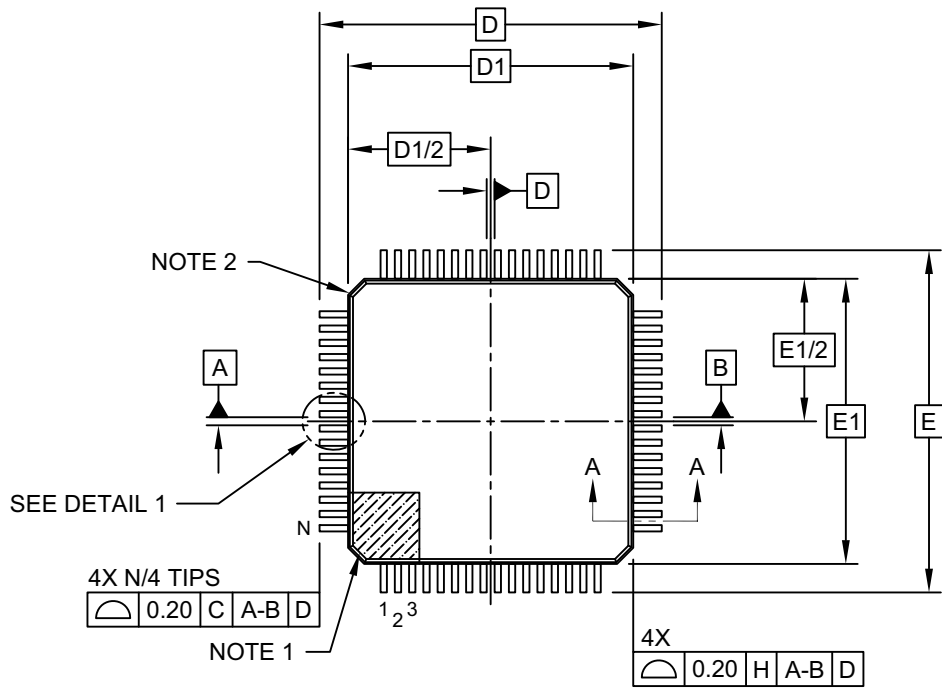
# PIC24FJ256GA110 FAMILY

## 29.2 Package Details

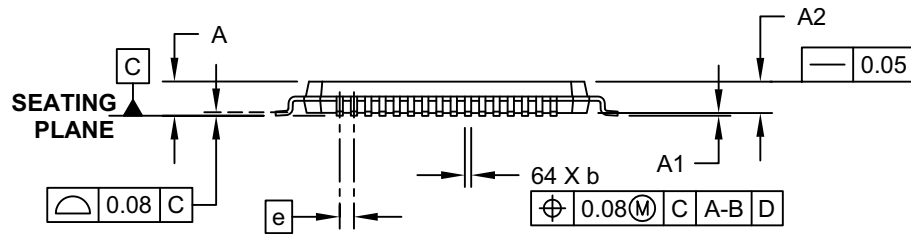
The following sections give the technical details of the packages.

### 64-Lead Plastic Thin Quad Flatpack (PT)-10x10x1 mm Body, 2.00 mm Footprint [TQFP]

**Note:** For the most current package drawings, please see the Microchip Packaging Specification located at <http://www.microchip.com/packaging>



TOP VIEW



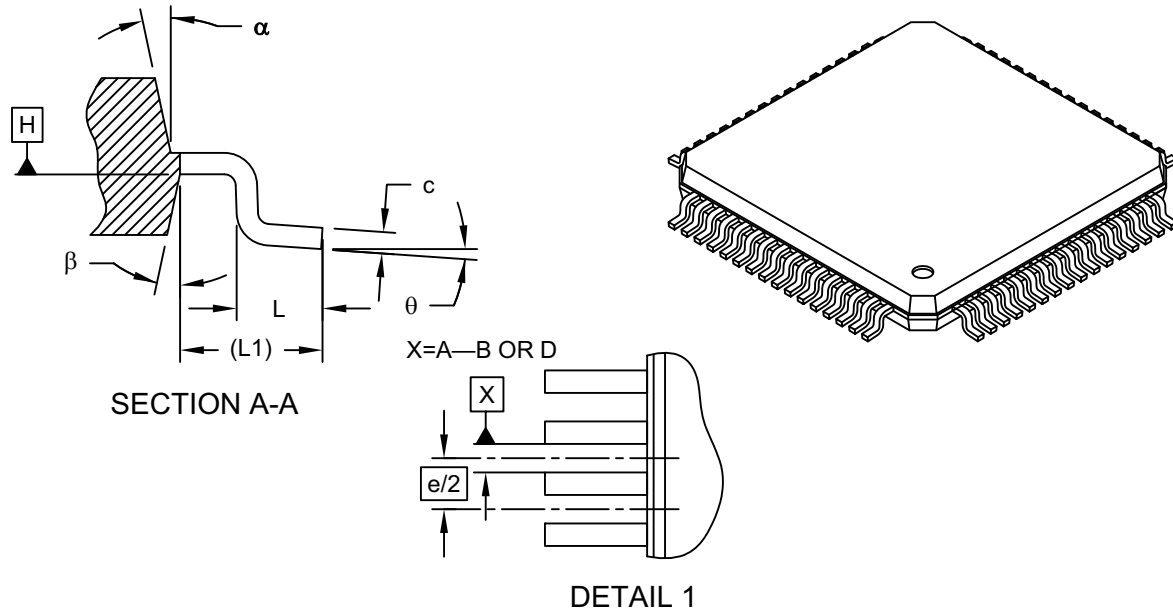
SIDE VIEW

Microchip Technology Drawing C04-085C Sheet 1 of 2

# PIC24FJ256GA110 FAMILY

## 64-Lead Plastic Thin Quad Flatpack (PT)-10x10x1 mm Body, 2.00 mm Footprint [TQFP]

**Note:** For the most current package drawings, please see the Microchip Packaging Specification located at <http://www.microchip.com/packaging>



Dimension Limits	Units	MILLIMETERS		
		MIN	NOM	MAX
Number of Leads	N	64		
Lead Pitch	e	0.50 BSC		
Overall Height	A	-	-	1.20
Molded Package Thickness	A2	0.95	1.00	1.05
Standoff	A1	0.05	-	0.15
Foot Length	L	0.45	0.60	0.75
Footprint	L1	1.00 REF		
Foot Angle	$\phi$	0°	3.5°	7°
Overall Width	E	12.00 BSC		
Overall Length	D	12.00 BSC		
Molded Package Width	E1	10.00 BSC		
Molded Package Length	D1	10.00 BSC		
Lead Thickness	c	0.09	-	0.20
Lead Width	b	0.17	0.22	0.27
Mold Draft Angle Top	$\alpha$	11°	12°	13°
Mold Draft Angle Bottom	$\beta$	11°	12°	13°

**Notes:**

- Pin 1 visual index feature may vary, but must be located within the hatched area.
- Chamfers at corners are optional; size may vary.
- Dimensions D1 and E1 do not include mold flash or protrusions. Mold flash or protrusions shall not exceed 0.25mm per side.
- Dimensioning and tolerancing per ASME Y14.5M

BSC: Basic Dimension. Theoretically exact value shown without tolerances.

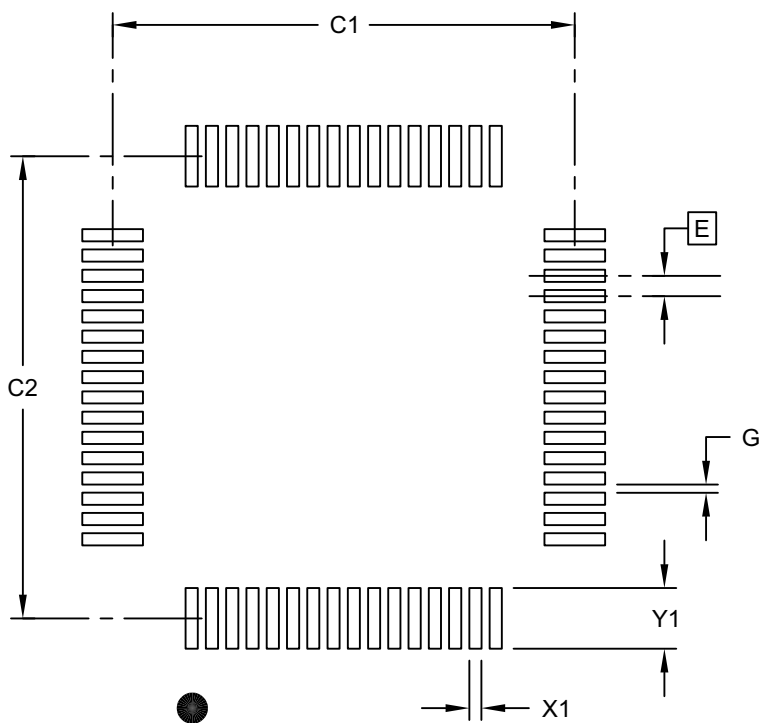
REF: Reference Dimension, usually without tolerance, for information purposes only.

Microchip Technology Drawing C04-085C Sheet 2 of 2

# PIC24FJ256GA110 FAMILY

## 64-Lead Plastic Thin Quad Flatpack (PT)-10x10x1 mm Body, 2.00 mm Footprint [TQFP]

**Note:** For the most current package drawings, please see the Microchip Packaging Specification located at <http://www.microchip.com/packaging>



RECOMMENDED LAND PATTERN

Dimension Limits	Units	MILLIMETERS		
		MIN	NOM	MAX
Contact Pitch	E	0.50 BSC		
Contact Pad Spacing	C1		11.40	
Contact Pad Spacing	C2		11.40	
Contact Pad Width (X28)	X1			0.30
Contact Pad Length (X28)	Y1			1.50
Distance Between Pads	G	0.20		

Notes:

1. Dimensioning and tolerancing per ASME Y14.5M

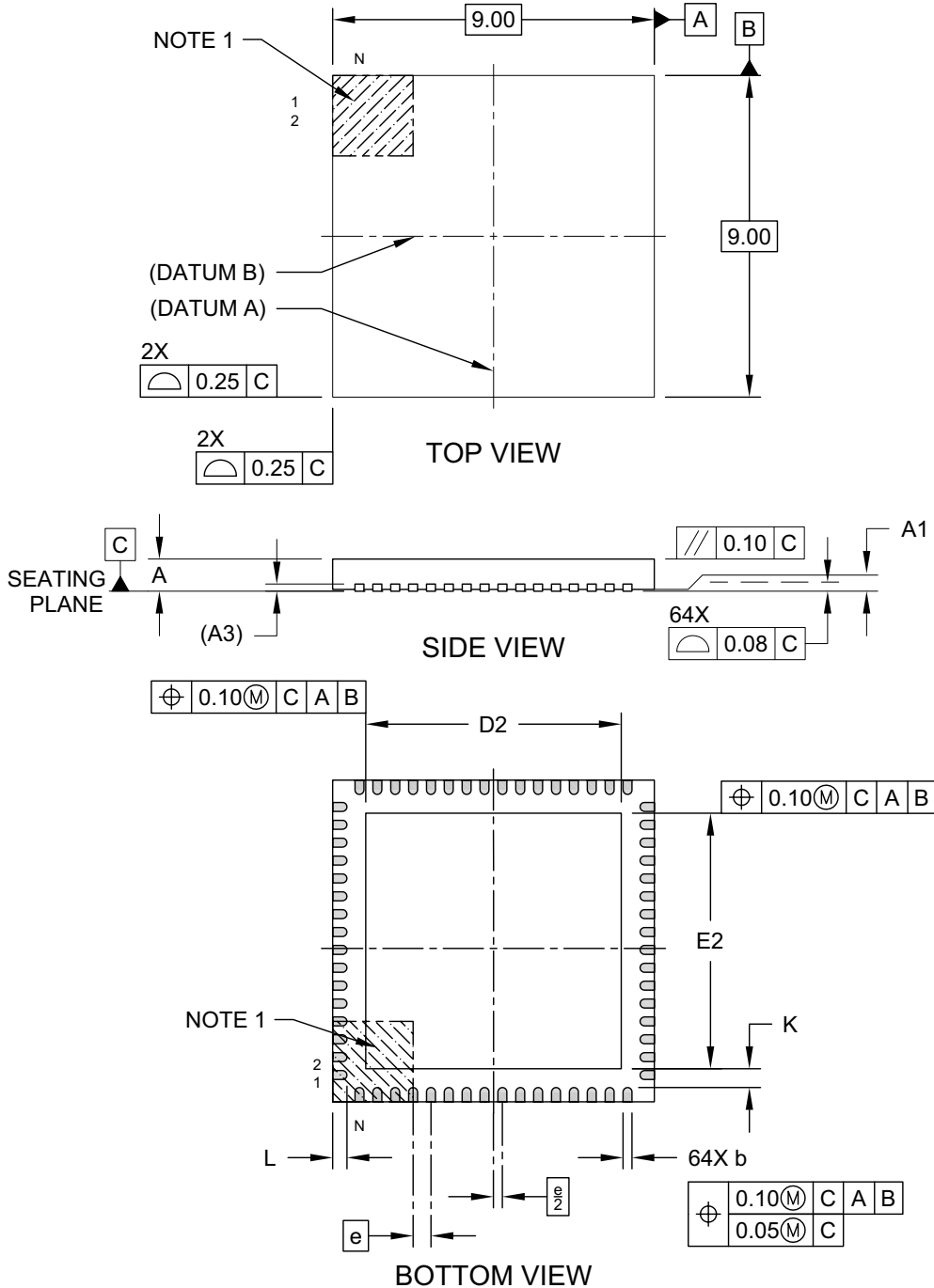
BSC: Basic Dimension. Theoretically exact value shown without tolerances.

Microchip Technology Drawing C04-2085B Sheet 1 of 1

# PIC24FJ256GA110 FAMILY

64-Lead Very Thin Plastic Quad Flat, No Lead Package (MR) – 9x9x0.9 mm Body [VQFN]  
With 7.15 x 7.15 Exposed Pad [Also called QFN]

**Note:** For the most current package drawings, please see the Microchip Packaging Specification located at <http://www.microchip.com/packaging>

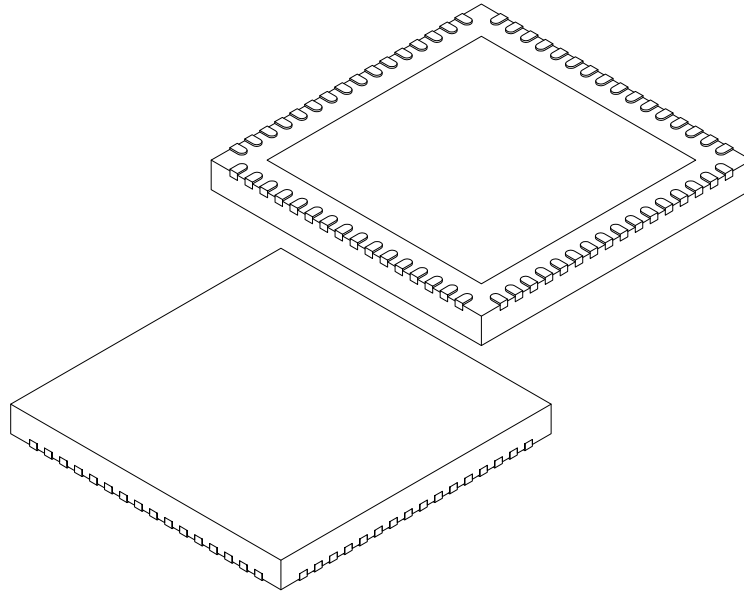


Microchip Technology Drawing C04-149D [MR] Sheet 1 of 2

# PIC24FJ256GA110 FAMILY

## 64-Lead Very Thin Plastic Quad Flat, No Lead Package (MR) – 9x9x0.9 mm Body [VQFN] With 7.15 x 7.15 Exposed Pad [Also called QFN]

**Note:** For the most current package drawings, please see the Microchip Packaging Specification located at <http://www.microchip.com/packaging>



Dimension Limits	Units	MILLIMETERS		
		MIN	NOM	MAX
Number of Pins	N	64		
Pitch	e	0.50 BSC		
Overall Height	A	0.80	0.90	1.00
Standoff	A1	0.00	0.02	0.05
Contact Thickness	A3	0.20 REF		
Overall Width	E	9.00 BSC		
Exposed Pad Width	E2	7.05	7.15	7.25
Overall Length	D	9.00 BSC		
Exposed Pad Length	D2	7.05	7.15	7.25
Contact Width	b	0.18	0.25	0.30
Contact Length	L	0.30	0.40	0.50
Contact-to-Exposed Pad	K	0.20	-	-

**Notes:**

1. Pin 1 visual index feature may vary, but must be located within the hatched area.
2. Package is saw singulated
3. Dimensioning and tolerancing per ASME Y14.5M

BSC: Basic Dimension. Theoretically exact value shown without tolerances.

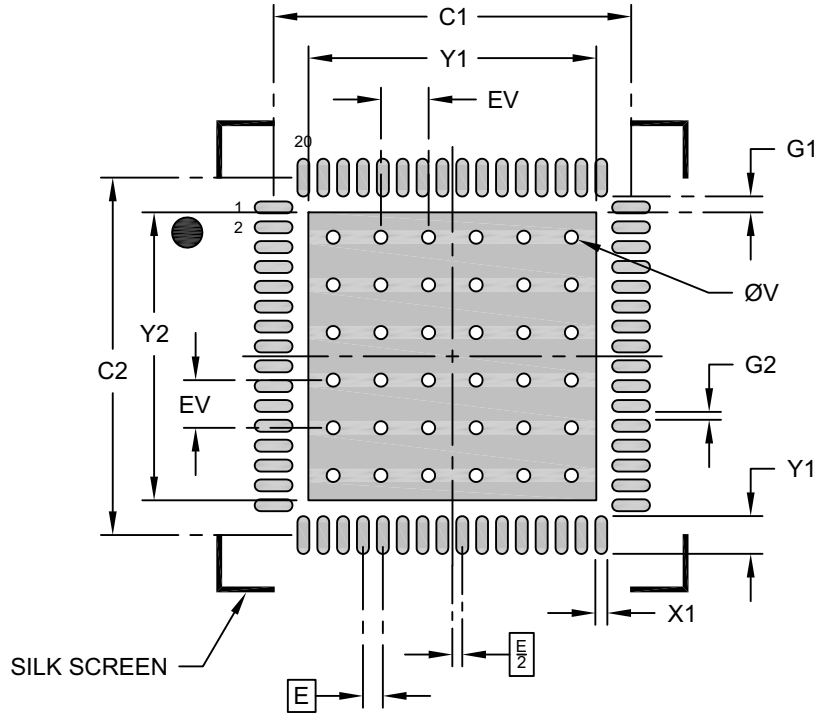
REF: Reference Dimension, usually without tolerance, for information purposes only.

Microchip Technology Drawing C04-149D [MR] Sheet 2 of 2

# PIC24FJ256GA110 FAMILY

**64-Lead Very Thin Plastic Quad Flat, No Lead Package (MR) – 9x9x0.9 mm Body [VQFN]  
With 7.15 x 7.15 Exposed Pad [Also called QFN]**

**Note:** For the most current package drawings, please see the Microchip Packaging Specification located at <http://www.microchip.com/packages>



**RECOMMENDED LAND PATTERN**

Dimension Limits	Units	MILLIMETERS		
		MIN	NOM	MAX
Contact Pitch	E	0.50 BSC		
Optional Center Pad Width	X2			7.25
Optional Center Pad Length	Y2			7.25
Contact Pad Spacing	C1		9.00	
Contact Pad Spacing	C2		9.00	
Contact Pad Width (X64)	X1			0.30
Contact Pad Length (X64)	Y1			0.95
Contact Pad to Center Pad (X64)	G1	0.40		
Spacing Between Contact Pads (X60)	G2	0.20		
Thermal Via Diameter	V		0.33	
Thermal Via Pitch	EV		1.20	

**Notes:**

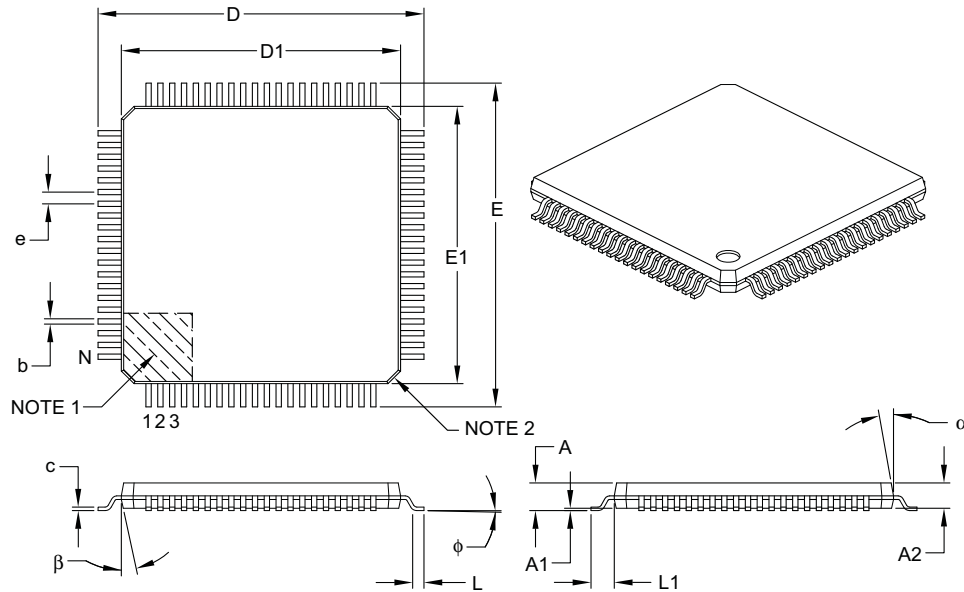
1. Dimensioning and tolerancing per ASME Y14.5M  
BSC: Basic Dimension. Theoretically exact value shown without tolerances.
2. For best soldering results, thermal vias, if used, should be filled or tented to avoid solder loss during reflow process

Microchip Technology Drawing C04-2149C [MR]

# PIC24FJ256GA110 FAMILY

## 80-Lead Plastic Thin Quad Flatpack (PT) – 12x12x1 mm Body, 2.00 mm [TQFP]

**Note:** For the most current package drawings, please see the Microchip Packaging Specification located at <http://www.microchip.com/packaging>



Units		MILLIMETERS		
Dimension Limits		MIN	NOM	MAX
Number of Leads	N	80		
Lead Pitch	e	0.50 BSC		
Overall Height	A	–	–	1.20
Molded Package Thickness	A2	0.95	1.00	1.05
Standoff	A1	0.05	–	0.15
Foot Length	L	0.45	0.60	0.75
Footprint	L1	1.00 REF		
Foot Angle	φ	0°	3.5°	7°
Overall Width	E	14.00 BSC		
Overall Length	D	14.00 BSC		
Molded Package Width	E1	12.00 BSC		
Molded Package Length	D1	12.00 BSC		
Lead Thickness	c	0.09	–	0.20
Lead Width	b	0.17	0.22	0.27
Mold Draft Angle Top	α	11°	12°	13°
Mold Draft Angle Bottom	β	11°	12°	13°

**Notes:**

- Pin 1 visual index feature may vary, but must be located within the hatched area.
- Chamfers at corners are optional; size may vary.
- Dimensions D1 and E1 do not include mold flash or protrusions. Mold flash or protrusions shall not exceed 0.25 mm per side.
- Dimensioning and tolerancing per ASME Y14.5M.

BSC: Basic Dimension. Theoretically exact value shown without tolerances.

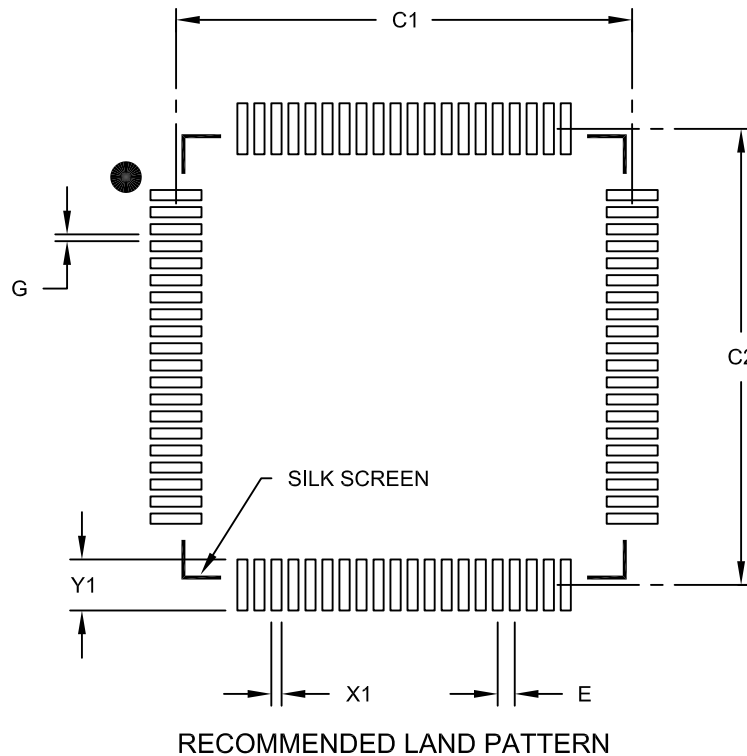
REF: Reference Dimension, usually without tolerance, for information purposes only.

Microchip Technology Drawing C04-092B

# PIC24FJ256GA110 FAMILY

80-Lead Plastic Thin Quad Flatpack (PT)-12x12x1mm Body, 2.00 mm Footprint [TQFP]

**Note:** For the most current package drawings, please see the Microchip Packaging Specification located at <http://www.microchip.com/packaging>



Dimension Limits	Units	MILLIMETERS		
		MIN	NOM	MAX
Contact Pitch	E	0.50 BSC		
Contact Pad Spacing	C1		13.40	
Contact Pad Spacing	C2		13.40	
Contact Pad Width (X80)	X1			0.30
Contact Pad Length (X80)	Y1			1.50
Distance Between Pads	G	0.20		

Notes:

1. Dimensioning and tolerancing per ASME Y14.5M

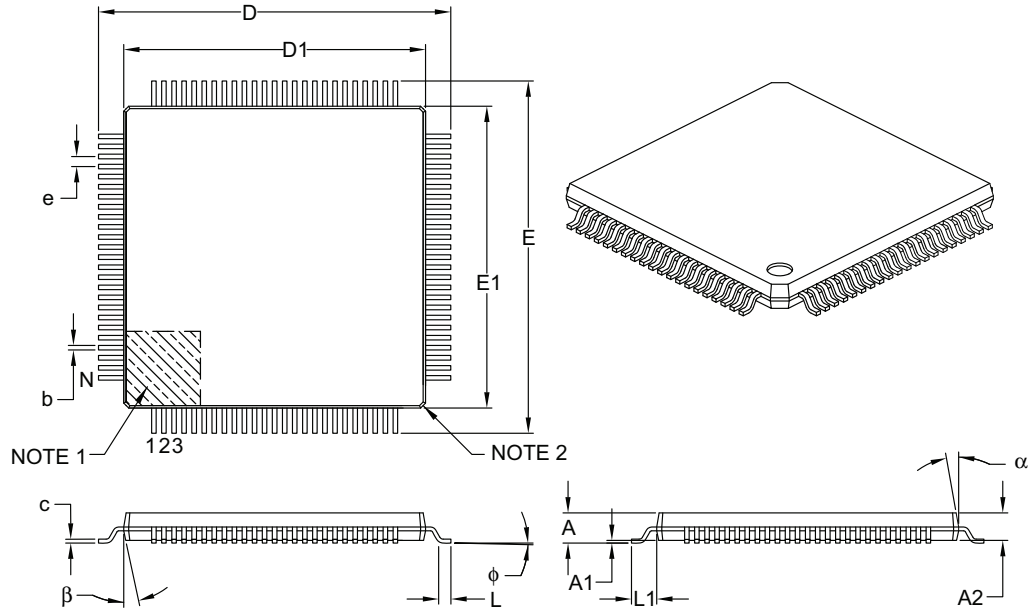
BSC: Basic Dimension. Theoretically exact value shown without tolerances.

Microchip Technology Drawing No. C04-2092B

# PIC24FJ256GA110 FAMILY

## 100-Lead Plastic Thin Quad Flatpack (PT) – 12x12x1 mm Body, 2.00 mm [TQFP]

**Note:** For the most current package drawings, please see the Microchip Packaging Specification located at <http://www.microchip.com/packaging>



		Units	MILLIMETERS		
Dimension Limits			MIN	NOM	MAX
Number of Leads	N		100		
Lead Pitch	e		0.40 BSC		
Overall Height	A	–	–	–	1.20
Molded Package Thickness	A2	0.95	1.00	–	1.05
Standoff	A1	0.05	–	–	0.15
Foot Length	L	0.45	0.60	–	0.75
Footprint	L1		1.00 REF		
Foot Angle	φ	0°	3.5°	–	7°
Overall Width	E		14.00 BSC		
Overall Length	D		14.00 BSC		
Molded Package Width	E1		12.00 BSC		
Molded Package Length	D1		12.00 BSC		
Lead Thickness	c	0.09	–	–	0.20
Lead Width	b	0.13	0.18	–	0.23
Mold Draft Angle Top	α	11°	12°	–	13°
Mold Draft Angle Bottom	β	11°	12°	–	13°

**Notes:**

1. Pin 1 visual index feature may vary, but must be located within the hatched area.
2. Chamfers at corners are optional; size may vary.
3. Dimensions D1 and E1 do not include mold flash or protrusions. Mold flash or protrusions shall not exceed 0.25 mm per side.
4. Dimensioning and tolerancing per ASME Y14.5M.

BSC: Basic Dimension. Theoretically exact value shown without tolerances.

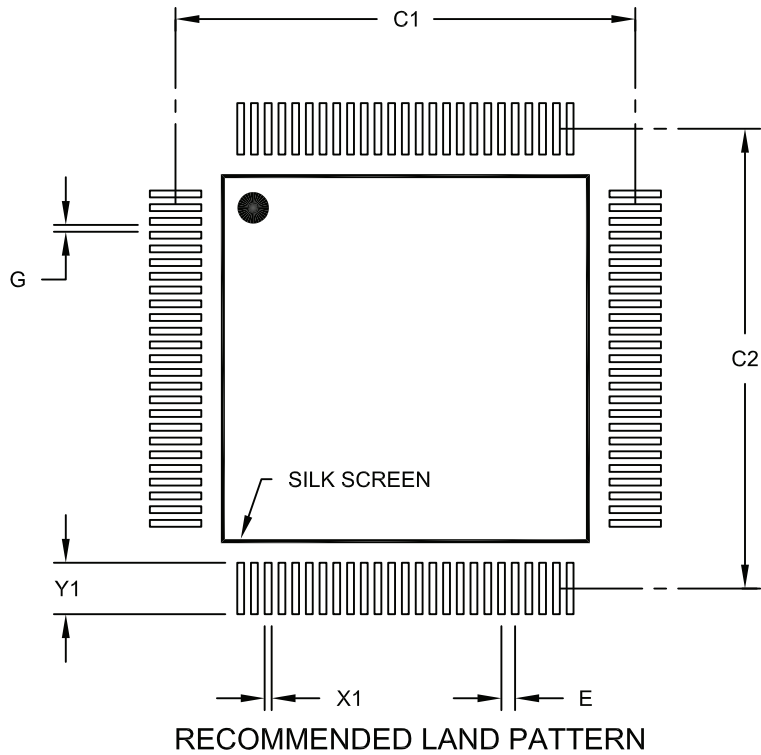
REF: Reference Dimension, usually without tolerance, for information purposes only.

Microchip Technology Drawing C04-100B

# PIC24FJ256GA110 FAMILY

## 100-Lead Plastic Thin Quad Flatpack (PT) – 12x12x1 mm Body, 2.00 mm [TQFP]

**Note:** For the most current package drawings, please see the Microchip Packaging Specification located at <http://www.microchip.com/packaging>



Dimension Limits	Units	MILLIMETERS		
		MIN	NOM	MAX
Contact Pitch	E	0.40 BSC		
Contact Pad Spacing	C1		13.40	
Contact Pad Spacing	C2		13.40	
Contact Pad Width (X100)	X1			0.20
Contact Pad Length (X100)	Y1			1.50
Distance Between Pads	G	0.20		

**Notes:**

1. Dimensioning and tolerancing per ASME Y14.5M

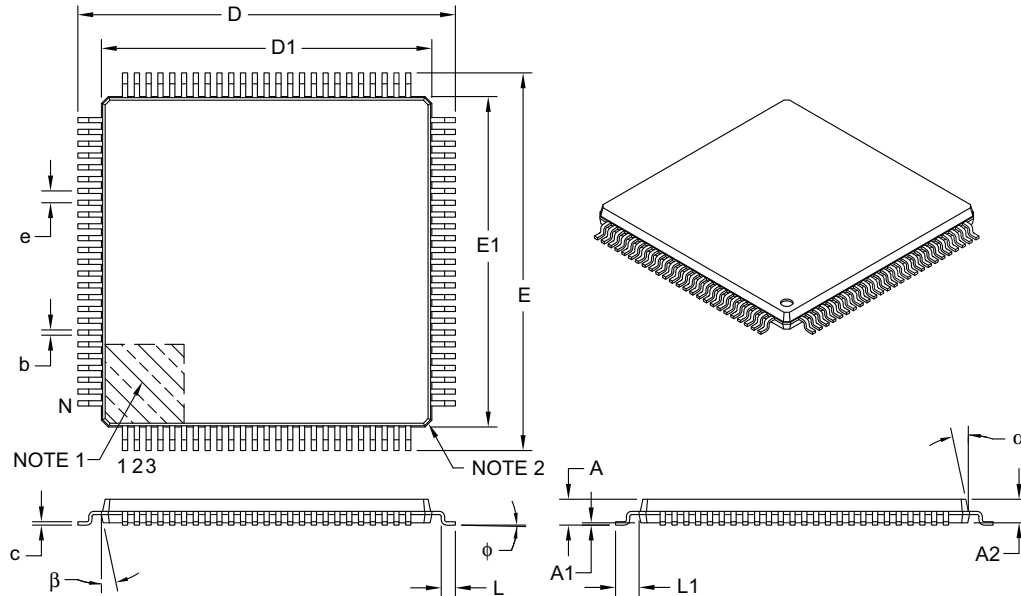
BSC: Basic Dimension. Theoretically exact value shown without tolerances.

Microchip Technology Drawing No. C04-2100A

# PIC24FJ256GA110 FAMILY

## 100-Lead Plastic Thin Quad Flatpack (PF) – 14x14x1 mm Body, 2.00 mm [TQFP]

**Note:** For the most current package drawings, please see the Microchip Packaging Specification located at <http://www.microchip.com/packaging>



Units		MILLIMETERS		
Dimension Limits		MIN	NOM	MAX
Number of Leads	N	100		
Lead Pitch	e	0.50 BSC		
Overall Height	A	–	–	1.20
Molded Package Thickness	A2	0.95	1.00	1.05
Standoff	A1	0.05	–	0.15
Foot Length	L	0.45	0.60	0.75
Footprint	L1	1.00 REF		
Foot Angle	$\phi$	0°	3.5°	7°
Overall Width	E	16.00 BSC		
Overall Length	D	16.00 BSC		
Molded Package Width	E1	14.00 BSC		
Molded Package Length	D1	14.00 BSC		
Lead Thickness	c	0.09	–	0.20
Lead Width	b	0.17	0.22	0.27
Mold Draft Angle Top	$\alpha$	11°	12°	13°
Mold Draft Angle Bottom	$\beta$	11°	12°	13°

**Notes:**

- Pin 1 visual index feature may vary, but must be located within the hatched area.
- Chamfers at corners are optional; size may vary.
- Dimensions D1 and E1 do not include mold flash or protrusions. Mold flash or protrusions shall not exceed 0.25 mm per side.
- Dimensioning and tolerancing per ASME Y14.5M.

BSC: Basic Dimension. Theoretically exact value shown without tolerances.

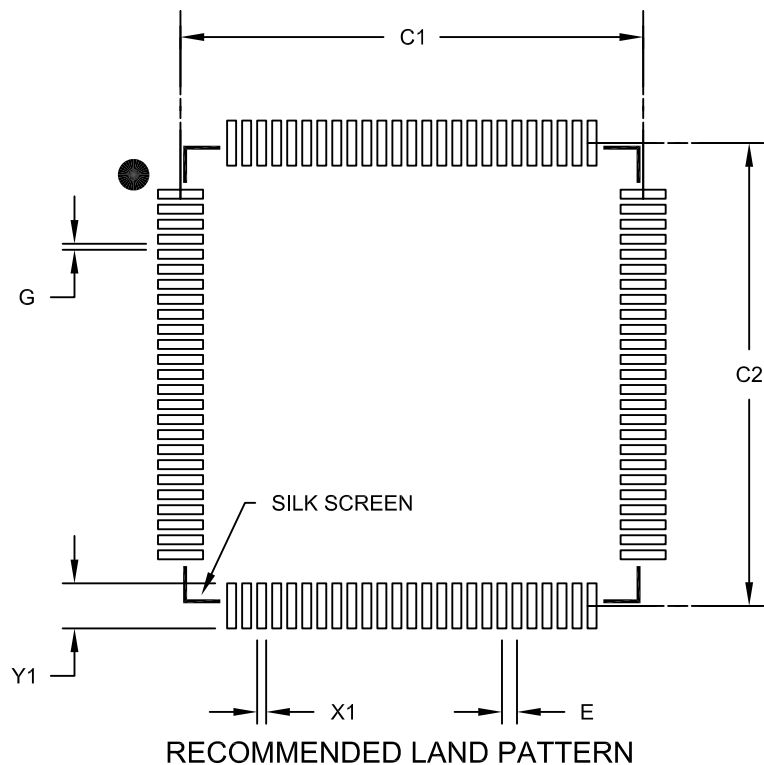
REF: Reference Dimension, usually without tolerance, for information purposes only.

Microchip Technology Drawing C04-110B

# PIC24FJ256GA110 FAMILY

100-Lead Plastic Thin Quad Flatpack (PF) - 14x14x1 mm Body 2.00 mm Footprint [TQFP]

**Note:** For the most current package drawings, please see the Microchip Packaging Specification located at <http://www.microchip.com/packaging>



Dimension Limits	Units	MILLIMETERS		
		MIN	NOM	MAX
Contact Pitch	E	0.50 BSC		
Contact Pad Spacing	C1		15.40	
Contact Pad Spacing	C2		15.40	
Contact Pad Width (X100)	X1			0.30
Contact Pad Length (X100)	Y1			1.50
Distance Between Pads	G	0.20		

Notes:

1. Dimensioning and tolerancing per ASME Y14.5M

BSC: Basic Dimension. Theoretically exact value shown without tolerances.

Microchip Technology Drawing No. C04-2110B

## APPENDIX A: REVISION HISTORY

### Revision A (December 2007)

Original data sheet for the PIC24FJ256GA110 family of devices.

### Revision B (February 2008)

Updates to [Section 28.0 “Electrical Characteristics”](#) and minor edits to text throughout document.

### Revision C (April 2009)

Updates to all Pin Diagrams to reflect the correct order of priority for multiplexed peripherals and adds the ASCK1 pin function.

Adds packaging information for the new 64-pin QFN package to [Section 29.0 “Packaging Information”](#) and the Product Information System.

Updates [Section 5.0 “Flash Program Memory”](#) with revised code examples in assembler and new code examples in C.

Updates [Section 6.2 “Device Reset Times”](#) with revised information, particularly [Table 6-3](#).

Adds the INTTREG register to [Section 4.0 “Memory Organization”](#) and [Section 7.0 “Interrupt Controller”](#).

Makes several additions and changes to [Section 10.0 “I/O Ports”](#), including:

- revision of [Section 10.4.2.1 “Peripheral Pin Select Function Priority”](#)
- addition of [Section 10.4.3.3 “Alternate Fixed Pin Mapping”](#)
- revisions to [Table 10-3](#), “Selectable Output Sources”
- addition of the ALTRP register (and in [Section 4.0 “Memory Organization”](#))

Updates [Section 15.0 “Serial Peripheral Interface \(SPI\)”](#) to include references to the ASCK1 pin function.

Updates [Section 20.0 “Programmable Cyclic Redundancy Check \(CRC\) Generator”](#) with new illustrations and a revised [Section 20.1 “User Interface”](#).

Updates [Section 21.0 “10-Bit High-Speed A/D Converter”](#) by changing all references to AD1CHS0 to AD1CHS (as well as other locations in the document). Also revises bit field descriptions in registers: AD1CON3 (bits 7:0) and AD1CHS (bits 12:8).

Makes minor text edits to bit descriptions in [Section 22.0 “Triple Comparator Module”](#) (Register 22-1) and [Section 24.0 “Charge Time Measurement Unit \(CTMU\)”](#) (Register 24-1).

Updates [Section 25.2 “On-Chip Voltage Regulator”](#) with revised text on the operation of the regulator during POR and Standby mode.

Updates [Section 25.5 “JTAG Interface”](#) to remove references to programming via the interface.

Makes multiple additions and changes to [Section 28.0 “Electrical Characteristics”](#), including:

- DC current characteristics for extended temperature operation (125°C)
- New DC characteristics of VBOR, VBG, TBG and ICNPD
- Addition of new VPEW specification for VDDCORE
- New AC characteristics for internal oscillator start-up time (TLPRC)
- Combination of all Internal RC Accuracy information into a single table

Makes other minor typographic corrections throughout the text.

### Revision D (December 2009)

Updates [Section 2.0 “Guidelines for Getting Started with 16-Bit Microcontrollers”](#) with the most current version.

Corrects annotations to the CN70 pin function in [Table 4-4](#) of [Section 4.2.4 “SFR Space”](#).

Corrects annotations to remappable output function 30 in [Register 10-37](#) of [Section 10.4 “Peripheral Pin Select \(PPS\)”](#).

Corrects the definitions for the WPEND and WPPF<7:0> Configuration bits in [Register 25-3](#) of [Section 25.1 “Configuration Bits”](#).

Updates [Section 28.0 “Electrical Characteristics”](#) with additional data for IDD at 60°C. Also corrects occurrences of “DISVREG” throughout the chapter, replacing them with “ENVREG” and the proper VDD/VSS connection information.

Makes other minor typographic corrections throughout the text.

# PIC24FJ256GA110 FAMILY

---

## Revision E (November 2010)

Updated [Section 2.0 “Guidelines for Getting Started with 16-Bit Microcontrollers”](#) with the most current version.

Updates to [Section 28.0 “Electrical Characteristics”](#) with tables being added and replaced from the FRM chapters.

Added 64-Kbyte device variants – PIC24FJ64GA106, PIC24FJ64GA108 and PIC24FJ64GA110.

Changed the CON bit to CEN to match other existing PIC24F, PIC24H and dsPIC® products.

Changed the VREFS bit to PMSLP to match other existing PIC24F, PIC24H and dsPIC® products.

Corrected the OCxCON2 and ICxCON2 Reset values in the register descriptions.

Defined SOSC and RTCC behavior during  $\overline{\text{MCLR}}$  events.

Corrected the RCFGAL Reset values in the register descriptions.

Updated Configuration Word unprogrammed information to more accurately reflect the devices' behavior.

Added electrical specifications from the *“PIC24F Family Reference Manual”*.

Corrected errors in the ENVREG pin operation descriptions.

Other minor typographic corrections throughout the document.

## Revision F (May 2019)

Updates to text formatting and editing throughout document.

- Sections:
  - Added [Section 16.3 “Clock Stretching”](#).
  - Updates to [Section 10.4.1 “Available Pins”](#), [Section 12.0 “Timer2/3 and Timer4/5”](#), [Section 25.1 “Configuration Bits”](#) and [Section 28.0 “Electrical Characteristics”](#).
- Tables:
  - Updates to [Table 4-12](#), [Table 7-2](#), [Table 10-2](#), [Table 28-3](#), [Table 28-7](#), [Table 28-10](#) and [Table 28-15](#)
- Registers:
  - Updates to [Register 10-20](#), [Register 22-1](#) and [Register 25-5](#).
- Figures:
  - Updates to [Pin Diagram \(100-Pin TQFP\)](#), [Figure 8-1](#), [Figure 11-1](#), [Figure 14-1](#), [Figure 14-2](#) and [Figure 19-1](#).



# PIC24FJ256GA110 FAMILY

CPU		
ALU	34	
Control Registers	32	
Core Registers	31	
CRC		
Operation in Power Save Modes	224	
Setup Example	223	
User Interface	224	
CTMU		
Measuring Capacitance	243	
Measuring Time	244	
Pulse Generation and Delay	244	
Customer Change Notification Service	326	
Customer Notification Service	326	
Customer Support	326	
Cyclic Redundancy Check. See CRC.		
<b>D</b>		
Data Memory		
Address Space	38	
Memory Map	38	
Near Data Space	39	
SFR Space	39	
Software Stack	54	
Space Organization, Alignment	39	
DC Characteristics		
I/O Pin Input Specifications	278	
I/O Pin Output Specifications	281	
Idle Current (IDLE)	274	
Internal Voltage Regulator Specifications	282	
Operating Current (IDD)	273	
Power-Down Current (IPD)	276	
Program Memory	281	
Temperature and Voltage Specifications	271	
Development Support	267	
Device Features (Summary)		
100-Pin	13	
64-Pin	11	
80-Pin	12	
Device Overview		
Core Features	9	
Family Member Details	10	
Other Special Features	10	
<b>E</b>		
Electrical Characteristics	269	
Absolute Maximum Ratings	269	
Thermal Operating Conditions	270	
V/F Graph	270	
ENVREG Pin	254	
Equations		
A/D Conversion Clock Period	235	
Calculating the PWM Period	172	
Calculation for Maximum PWM Resolution	173	
Computing Baud Rate Reload Value	189	
Relationship Between Device and		
SPI Clock Speed	186	
RTCC Calibration	221	
UART Baud Rate with BRGH = 0	196	
UART Baud Rate with BRGH = 1	196	
Errata	6	
<b>F</b>		
Flash Configuration Words	37	
Flash Program Memory		
and Table Instructions	59	
Enhanced ICSP Operation	60	
JTAG Operation	60	
Operations	60	
Programming Algorithm	62	
RTSP Operation	60	
Single Word Programming	65	
<b>G</b>		
Getting Started Guidelines	23	
Analog/Digital Pin Configuration During ICSP	28	
Basic Connections	23	
External Oscillator Pins	27	
ICSP Pins	26	
Master Clear Pin ( $\overline{\text{MCLR}}$ )	24	
Oscillator Circuit Placement	27	
Power Supply Pins	24	
Unused I/Os	28	
Voltage Regulator Pins	25	
<b>I</b>		
I/O Ports	129	
Analog Port Pins Configuration	130	
Input Change Notification	131	
Open-Drain Configuration	130	
Parallel (PIO)	129	
Peripheral Pin Select	131	
Pull-ups and Pull-Downs	131	
I <sup>2</sup> C		
Clock Rates	189	
Communicating as Master in Single		
Master Environment	187	
Peripheral Remapping Options	187	
Reserved Addresses	189	
Setting Baud Rate When Operating as		
Bus Master	189	
Slave Address Masking	189	
Input Capture		
32-Bit Cascaded Mode	166	
Operations	166	
Synchronous and Trigger Modes	165	
Input Capture with Dedicated Timer	165	
Instruction Set		
Overview	261	
Summary	259	
Symbols Used in Opcode Descriptions	260	
Inter-Integrated Circuit (I <sup>2</sup> C)	187	
Inter-Integrated Circuit. See I <sup>2</sup> C.		
Internet Address	326	
Interrupt Controller	73	
Interrupt Vector Table (IVT)	73	
Interrupts		
Implemented Vectors	75	
Reset Sequence	73	
Setup and Service Procedures	116	
Trap Vectors	74	
Vector Table	74	

# PIC24FJ256GA110 FAMILY

<b>J</b>			
JTAG Interface .....	258		
<b>M</b>			
Microchip Internet Web Site .....	326		
<b>N</b>			
Near Data Space .....	39		
<b>O</b>			
Oscillator Configuration			
Bit Values for Clock Selection .....	118		
Clock Switching .....	122		
Sequence .....	123		
Control Registers .....	119		
CPU Clocking Scheme .....	118		
Initial Configuration on POR .....	118		
Reference Clock Output .....	124		
Output Compare			
Cascaded (32-Bit) Mode .....	169		
Operations .....	170		
Synchronous and Trigger Modes .....	169		
Output Compare with Dedicated Timer .....	169		
<b>P</b>			
Packaging .....	305		
Details .....	307		
Marking .....	305		
Parallel Master Port. <i>See</i> PMP.			
Peripheral Enable Bits .....	128		
Peripheral Module Disable Bits .....	128		
Peripheral Pin Select (PPS) .....	131		
Alternate Fixed Pin Mapping .....	132		
Available Peripherals and Pins .....	132		
Configuration Control .....	135		
Considerations for Use .....	136		
Control Registers .....	137		
Input Mapping .....	132		
Mapping Exceptions .....	135		
Output Mapping .....	132		
Peripheral Priority .....	132		
Selectable Input Sources .....	133		
Selectable Output Sources .....	134		
Pinout Descriptions .....	15–22		
PMSLP Bit .....	68		
and Wake-up Time .....	127, 255		
Power-Saving Features .....	127		
Modes			
Doze .....	128		
Idle .....	128		
Sleep .....	127		
Product Identification System .....	328		
Program Memory			
Access Using Table Instructions .....	56		
Address Space .....	35		
Addressing .....	54		
Flash Configuration Words .....	37		
Memory Maps .....	36		
Organization .....	37		
Program Space Visibility .....	57		
Program Space Visibility (PSV) .....	57		
Program Verification .....	256		
Programmer's Model .....	29		
Pulse-Width Modulation (PWM) Mode .....	171		
Pulse-Width Modulation. <i>See</i> PWM.			
		PWM	
		Duty Cycle and Period .....	172
		<b>R</b>	
		Real-Time Clock and Calendar (RTCC) .....	213
		Real-Time Clock and Calendar. <i>See</i> RTCC.	
		Referenced Sources .....	7
		Register Maps	
		ADC .....	50
		Comparators .....	51
		CPU Core .....	40
		CRC .....	51
		CTMU .....	50
		I <sup>2</sup> C .....	46
		ICN .....	41
		Input Capture .....	44
		Interrupt Controller .....	42
		NVM .....	53
		Output Compare .....	45
		Pad Configuration .....	49
		Parallel Master/Slave Port .....	51
		Peripheral Pin Select .....	52
		PMD .....	53
		PORTA .....	48
		PORTB .....	48
		PORTC .....	48
		PORTD .....	48
		PORTE .....	49
		PORTF .....	49
		PORTG .....	49
		Real-Time Clock and Calendar .....	51
		SPI .....	47
		System .....	53
		Timers .....	43
		UART .....	47
		Registers	
		AD1CHS (A/D Input Select) .....	232
		AD1CON1 (A/D Control 1) .....	229
		AD1CON2 (A/D Control 2) .....	230
		AD1CON3 (A/D Control 3) .....	231
		AD1CSSL (A/D Input Scan Select Low) .....	234
		AD1PCFGH (A/D Port Configuration High) .....	233
		AD1PCFGL (A/D Port Configuration Low) .....	233
		ALCFGPRPT (Alarm Configuration) .....	217
		ALMINSEC (Alarm Minutes and Seconds Value) ...	221
		ALMTHDY (Alarm Month and Day Value) .....	220
		ALTRP (Alternate Peripheral Pin Mapping) .....	156
		ALWDHR (Alarm Weekday and Hours Value) .....	220
		CLKDIV (Clock Divider) .....	121
		CMSTAT (Comparator Status) .....	240
		CMxCON (Comparator x Control) .....	239
		CORCON (CPU Control) .....	33, 78
		CRCCON (CRC Control) .....	225
		CRCXOR (CRC XOR Polynomial) .....	226
		CTMUCON (CTMU Control) .....	245
		CTMUICON (CTMU Current Control) .....	246
		CVRCON (Comparator Voltage	
		Reference Control) .....	242
		CW1 (Flash Configuration Word 1) .....	248
		CW2 (Flash Configuration Word 2) .....	250
		CW3 (Flash Configuration Word 3) .....	251
		DEVID (Device ID) .....	252
		DEVREV (Device Revision) .....	253
		I2CxCON (I2Cx Control) .....	190
		I2CxMSK (I2Cx Slave Mode Address Mask) .....	194
		I2CxSTAT (I2Cx Status) .....	192

# PIC24FJ256GA110 FAMILY

ICxCON1 (Input Capture x Control 1) .....	167	RPINR18 (Peripheral Pin Select Input 18) .....	143
ICxCON2 (Input Capture x Control 2) .....	168	RPINR19 (Peripheral Pin Select Input 19) .....	143
IEC0 (Interrupt Enable Control 0) .....	87	RPINR2 (Peripheral Pin Select Input 2) .....	138
IEC1 (Interrupt Enable Control 1) .....	88	RPINR20 (Peripheral Pin Select Input 20) .....	144
IEC2 (Interrupt Enable Control 2) .....	90	RPINR21 (Peripheral Pin Select Input 21) .....	144
IEC3 (Interrupt Enable Control 3) .....	91	RPINR22 (Peripheral Pin Select Input 22) .....	145
IEC4 (Interrupt Enable Control 4) .....	92	RPINR23 (Peripheral Pin Select Input 23) .....	145
IEC5 (Interrupt Enable Control 5) .....	93	RPINR27 (Peripheral Pin Select Input 27) .....	146
IFS0 (Interrupt Flag Status 0) .....	81	RPINR28 (Peripheral Pin Select Input 28) .....	146
IFS1 (Interrupt Flag Status 1) .....	82	RPINR29 (Peripheral Pin Select Input 29) .....	147
IFS2 (Interrupt Flag Status 2) .....	83	RPINR3 (Peripheral Pin Select Input 3) .....	138
IFS3 (Interrupt Flag Status 3) .....	84	RPINR4 (Peripheral Pin Select Input 4) .....	139
IFS4 (Interrupt Flag Status 4) .....	85	RPINR7 (Peripheral Pin Select Input 7) .....	139
IFS5 (Interrupt Flag Status 5) .....	86	RPINR8 (Peripheral Pin Select Input 8) .....	140
INTCON1 (Interrupt Control 1) .....	79	RPINR9 (Peripheral Pin Select Input 9) .....	140
INTCON2 (Interrupt Control 2) .....	80	RPOR0 (PPS Output 0) .....	148
INTTREG (Interrupt Control and Status) .....	115	RPOR1 (PPS Output 1) .....	148
IPC0 (Interrupt Priority Control 0) .....	94	RPOR10 (PPS Output 10) .....	153
IPC1 (Interrupt Priority Control 1) .....	95	RPOR11 (PPS Output 11) .....	153
IPC10 (Interrupt Priority Control 10) .....	104	RPOR12 (PPS Output 12) .....	154
IPC11 (Interrupt Priority Control 11) .....	105	RPOR13 (PPS Output 13) .....	154
IPC12 (Interrupt Priority Control 12) .....	106	RPOR14 (PPS Output 14) .....	155
IPC13 (Interrupt Priority Control 13) .....	107	RPOR15 (PPS Output 15) .....	155
IPC15 (Interrupt Priority Control 15) .....	108	RPOR2 (PPS Output 2) .....	149
IPC16 (Interrupt Priority Control 16) .....	109	RPOR3 (PPS Output 3) .....	149
IPC18 (Interrupt Priority Control 18) .....	110	RPOR4 (PPS Output 4) .....	150
IPC19 (Interrupt Priority Control 19) .....	110	RPOR5 (PPS Output 5) .....	150
IPC2 (Interrupt Priority Control 2) .....	96	RPOR6 (PPS Output 6) .....	151
IPC20 (Interrupt Priority Control 20) .....	111	RPOR7 (PPS Output 7) .....	151
IPC21 (Interrupt Priority Control 21) .....	112	RPOR8 (PPS Output 8) .....	152
IPC22 (Interrupt Priority Control 22) .....	113	RPOR9 (PPS Output 9) .....	152
IPC23 (Interrupt Priority Control 23) .....	114	SPIxCON1 (SPIx Control 1) .....	182
IPC3 (Interrupt Priority Control 3) .....	97	SPIxCON2 (SPIx Control 2) .....	183
IPC4 (Interrupt Priority Control 4) .....	98	SPIxSTAT (SPIx Status and Control) .....	180
IPC5 (Interrupt Priority Control 5) .....	99	SR (ALU STATUS, in CPU) .....	78
IPC6 (Interrupt Priority Control 6) .....	100	SR (ALU STATUS) .....	32
IPC7 (Interrupt Priority Control 7) .....	101	T1CON (Timer1 Control) .....	158
IPC8 (Interrupt Priority Control 8) .....	102	TxCON (Timer2 and Timer4 Control) .....	162
IPC9 (Interrupt Priority Control 9) .....	103	TyCON (Timer3 and Timer5 Control) .....	163
MINSEC (RTCC Minutes and Seconds Value) .....	219	UxMODE (UARTx Mode) .....	198
MTHDY (RTCC Month and Day Value) .....	218	UxSTA (UARTx Status and Control) .....	200
NVMCON (Flash Memory Control) .....	61	WKDYHR (RTCC Weekday and Hours Value) .....	219
OCxCON1 (Output Compare x Control 1) .....	174	YEAR (RTCC Year Value) .....	218
OCxCON2 (Output Compare x Control 2) .....	175		
OSCCON (Oscillator Control) .....	119	<b>Resets</b>	
OSCTUN (FRC Oscillator Tune) .....	122	Clock Source Selection .....	69
PADCFG1 (Pad Configuration Control) .....	209, 216	Delay Times .....	70
PMADDR (PMP Address) .....	207	RCON Flag Operation .....	69
PMAEN (PMP Enable) .....	207	SFR States .....	71
PMCON (PMP Control) .....	204	<b>Revision History</b> .....	319
PMODE (PMP Mode) .....	206	<b>RTCC</b>	
PMSTAT (PMP Status) .....	208	Alarm Configuration .....	222
RCFGCAL (RTCC Calibration and Configuration) .....	215	Calibration .....	221
RCON (Reset Control) .....	68	Register Mapping .....	214
REFOCON (Reference Oscillator Control) .....	125		
RPINR0 (Peripheral Pin Select Input 0) .....	137	<b>S</b>	
RPINR1 (Peripheral Pin Select Input 1) .....	137	Selective Peripheral Module Control .....	128
RPINR10 (Peripheral Pin Select Input 10) .....	141	Serial Peripheral Interface. <i>See</i> SPI.	
RPINR11 (Peripheral Pin Select Input 11) .....	141	SFR Space .....	39
RPINR15 (Peripheral Pin Select Input 15) .....	142	Software Stack .....	54
RPINR17 (Peripheral Pin Select Input 17) .....	142		

# PIC24FJ256GA110 FAMILY

## T

Timer1 .....	157
Timer2/3 and Timer4/5 .....	159
Timing Diagrams	
CLKO and I/O Characteristics .....	286
External Clock Requirements .....	284
I <sup>2</sup> C Bus Data (Master Mode) .....	298
I <sup>2</sup> C Bus Data (Slave Mode) .....	300
I <sup>2</sup> C Bus Start/Stop Bits (Master Mode) .....	297
I <sup>2</sup> C Bus Start/Stop Bits (Slave Mode) .....	299
Input Capture .....	291
Output Compare .....	296
Parallel Master Port Read .....	302
Parallel Master Port Write .....	303
Parallel Slave Port .....	301
PWM Requirements .....	296
Reset, Watchdog Timer, Oscillator Start-up Timer, Power-up Timer Characteristics .....	272, 289
SPIx Master Mode (CKE = 0) .....	292
SPIx Master Mode (CKE = 1) .....	293
SPIx Slave Mode (CKE = 0) .....	294
SPIx Slave Mode (CKE = 1) .....	295
UART Baud Rate Generator Output .....	290
UART Start Bit Edge Detection .....	290
Timing Requirements	
Input Capture .....	291
Output Compare .....	296
Parallel Slave Port .....	301
PWM .....	296
SPIx Slave Mode (CKE = 1) .....	295
Triple Comparator Module .....	237

## U

UART	
Baud Rate Generator (BRG) .....	196
IrDA Support .....	197
Operation of $\overline{UxCTS}$ and $\overline{UxRTS}$ Pins .....	197
Receiving .....	197
Transmitting	
8-Bit Data Mode .....	197
9-Bit Data Mode .....	197
Break and Sync Sequence .....	197
Universal Asynchronous Receiver Transmitter. See UART.	

## V

VDDCORE/VCAP Pin .....	254
Voltage Regulator (On-Chip) .....	254
and BOR .....	255
and POR .....	255
Power-up Requirements .....	255
Standby Mode .....	255
Tracking Mode .....	254

## W

Watchdog Timer (WDT) .....	255
Control Register .....	256
Windowed Operation .....	256
WWW Address .....	326
WWW, On-Line Support .....	6

# PIC24FJ256GA110 FAMILY

---

NOTES:

# PIC24FJ256GA110 FAMILY

---

## THE MICROCHIP WEBSITE

Microchip provides online support via our WWW site at [www.microchip.com](http://www.microchip.com). This website is used as a means to make files and information easily available to customers. Accessible by using your favorite Internet browser, the website contains the following information:

- **Product Support** – Data sheets and errata, application notes and sample programs, design resources, user's guides and hardware support documents, latest software releases and archived software
- **General Technical Support** – Frequently Asked Questions (FAQ), technical support requests, online discussion groups, Microchip consultant program member listing
- **Business of Microchip** – Product selector and ordering guides, latest Microchip press releases, listing of seminars and events, listings of Microchip sales offices, distributors and factory representatives

## CUSTOMER CHANGE NOTIFICATION SERVICE

Microchip's customer notification service helps keep customers current on Microchip products. Subscribers will receive e-mail notification whenever there are changes, updates, revisions or errata related to a specified product family or development tool of interest.

To register, access the Microchip website at [www.microchip.com](http://www.microchip.com). Under "Support", click on "Customer Change Notification" and follow the registration instructions.

## CUSTOMER SUPPORT

Users of Microchip products can receive assistance through several channels:

- Distributor or Representative
- Local Sales Office
- Field Application Engineer (FAE)
- Technical Support

Customers should contact their distributor, representative or Field Application Engineer (FAE) for support. Local sales offices are also available to help customers. A listing of sales offices and locations is included in the back of this document.

**Technical support is available through the website at: <http://microchip.com/support>**

# PIC24FJ256GA110 FAMILY

---

NOTES:

# PIC24FJ256GA110 FAMILY

## PRODUCT IDENTIFICATION SYSTEM

To order or obtain information, e.g., on pricing or delivery, refer to the factory or the listed sales office.

	PIC	24	FJ	256	GA1	10	T	- I /	PT	- XXX
<b>Microchip Trademark</b>	_____	_____	_____	_____	_____	_____	_____	_____	_____	_____
<b>Architecture</b>	_____	_____	_____	_____	_____	_____	_____	_____	_____	_____
<b>Flash Memory Family</b>	_____	_____	_____	_____	_____	_____	_____	_____	_____	_____
<b>Program Memory Size (KB)</b>	_____	_____	_____	_____	_____	_____	_____	_____	_____	_____
<b>Product Group</b>	_____	_____	_____	_____	_____	_____	_____	_____	_____	_____
<b>Pin Count</b>	_____	_____	_____	_____	_____	_____	_____	_____	_____	_____
<b>Tape and Reel Flag (if applicable)</b>	_____	_____	_____	_____	_____	_____	_____	_____	_____	_____
<b>Temperature Range</b>	_____	_____	_____	_____	_____	_____	_____	_____	_____	_____
<b>Package</b>	_____	_____	_____	_____	_____	_____	_____	_____	_____	_____
<b>Pattern</b>	_____	_____	_____	_____	_____	_____	_____	_____	_____	_____

Architecture	24	= 16-bit modified Harvard without DSP
Flash Memory Family	FJ	= Flash program memory
Product Group	GA1	= General purpose microcontrollers
Pin Count	06	= 64-pin
	08	= 80-pin
	10	= 100-pin
Temperature Range	I	= -40°C to +85°C (Industrial)
	E	= -40°C to +125°C (Extended)
Package	PT	= 64-Lead Plastic Thin Quad Flatpack – 10x10x1 mm (TQFP)
	MR	= 64-lead Plastic Quad Flat, No Leads – 9x9x.9 mm (QFN)
	PT	= 80-Lead Plastic Thin Quad Flatpack – 12x12x1 mm (TQFP)
	PT	= 100-Lead Plastic Thin Quad Flatpack – 12x12x1 mm (TQFP)
	PF	= 100-Lead Plastic Thin Quad Flatpack – 14x14x1 mm (TQFP)
Pattern		Three-digit QTP, SQTP, Code or Special Requirements (blank otherwise)
	ES	= Engineering Sample

### Examples:

- PIC24FJ128GA106-I/PT:  
General Purpose PIC24F, 128-Kbyte Program Memory, 64-Pin, Industrial Temp., TQFP Package.
- PIC24FJ256GA110-I/PT:  
General Purpose PIC24F, 256-Kbyte Program memory, 100-Pin, Industrial Temp., TQFP Package.

# PIC24FJ256GA110 FAMILY

---

NOTES:

---

**Note the following details of the code protection feature on Microchip devices:**

- Microchip products meet the specification contained in their particular Microchip Data Sheet.
- Microchip believes that its family of products is one of the most secure families of its kind on the market today, when used in the intended manner and under normal conditions.
- There are dishonest and possibly illegal methods used to breach the code protection feature. All of these methods, to our knowledge, require using the Microchip products in a manner outside the operating specifications contained in Microchip's Data Sheets. Most likely, the person doing so is engaged in theft of intellectual property.
- Microchip is willing to work with the customer who is concerned about the integrity of their code.
- Neither Microchip nor any other semiconductor manufacturer can guarantee the security of their code. Code protection does not mean that we are guaranteeing the product as “unbreakable.”

Code protection is constantly evolving. We at Microchip are committed to continuously improving the code protection features of our products. Attempts to break Microchip's code protection feature may be a violation of the Digital Millennium Copyright Act. If such acts allow unauthorized access to your software or other copyrighted work, you may have a right to sue for relief under that Act.

---

Information contained in this publication regarding device applications and the like is provided only for your convenience and may be superseded by updates. It is your responsibility to ensure that your application meets with your specifications. MICROCHIP MAKES NO REPRESENTATIONS OR WARRANTIES OF ANY KIND WHETHER EXPRESS OR IMPLIED, WRITTEN OR ORAL, STATUTORY OR OTHERWISE, RELATED TO THE INFORMATION, INCLUDING BUT NOT LIMITED TO ITS CONDITION, QUALITY, PERFORMANCE, MERCHANTABILITY OR FITNESS FOR PURPOSE. Microchip disclaims all liability arising from this information and its use. Use of Microchip devices in life support and/or safety applications is entirely at the buyer's risk, and the buyer agrees to defend, indemnify and hold harmless Microchip from any and all damages, claims, suits, or expenses resulting from such use. No licenses are conveyed, implicitly or otherwise, under any Microchip intellectual property rights unless otherwise stated.

*Microchip received ISO/TS-16949:2009 certification for its worldwide headquarters, design and wafer fabrication facilities in Chandler and Tempe, Arizona; Gresham, Oregon and design centers in California and India. The Company's quality system processes and procedures are for its PIC® MCUs and dsPIC® DSCs, KEELOQ® code hopping devices, Serial EEPROMs, microperipherals, nonvolatile memory and analog products. In addition, Microchip's quality system for the design and manufacture of development systems is ISO 9001:2000 certified.*

**QUALITY MANAGEMENT SYSTEM  
CERTIFIED BY DNV  
= ISO/TS 16949 =**

### Trademarks

The Microchip name and logo, the Microchip logo, AnyRate, AVR, AVR logo, AVR Freaks, BitCloud, chipKIT, chipKIT logo, CryptoMemory, CryptoRF, dsPIC, FlashFlex, flexPWR, Heldo, JukeBlox, KeeLoq, Kleer, LANCheck, LINK MD, maXStylus, maXTouch, MediaLB, megaAVR, MOST, MOST logo, MPLAB, OptoLyzer, PIC, picoPower, PICSTART, PIC32 logo, Prochip Designer, QTouch, SAM-BA, SpyNIC, SST, SST Logo, SuperFlash, tinyAVR, UNI/O, and XMEGA are registered trademarks of Microchip Technology Incorporated in the U.S.A. and other countries.

ClockWorks, The Embedded Control Solutions Company, EtherSynch, Hyper Speed Control, HyperLight Load, IntellIMOS, mTouch, Precision Edge, and Quiet-Wire are registered trademarks of Microchip Technology Incorporated in the U.S.A.

Adjacent Key Suppression, AKS, Analog-for-the-Digital Age, Any Capacitor, AnyIn, AnyOut, BodyCom, CodeGuard, CryptoAuthentication, CryptoAutomotive, CryptoCompanion, CryptoController, dsPICDEM, dsPICDEM.net, Dynamic Average Matching, DAM, ECAN, EtherGREEN, In-Circuit Serial Programming, ICSP, INICnet, Inter-Chip Connectivity, JitterBlocker, KleerNet, KleerNet logo, memBrain, Mindi, MiWi, motorBench, MPASM, MPF, MPLAB Certified logo, MPLIB, MPLINK, MultiTRAK, NetDetach, Omniscient Code Generation, PICDEM, PICDEM.net, PICKit, PICtail, PowerSmart, PureSilicon, QMatrix, REAL ICE, Ripple Blocker, SAM-ICE, Serial Quad I/O, SMART-I.S., SQI, SuperSwitcher, SuperSwitcher II, Total Endurance, TSHARC, USBCheck, VariSense, ViewSpan, WiperLock, Wireless DNA, and ZENA are trademarks of Microchip Technology Incorporated in the U.S.A. and other countries.

SQTP is a service mark of Microchip Technology Incorporated in the U.S.A.

Silicon Storage Technology is a registered trademark of Microchip Technology Inc. in other countries.

GestIC is a registered trademark of Microchip Technology Germany II GmbH & Co. KG, a subsidiary of Microchip Technology Inc., in other countries.

All other trademarks mentioned herein are property of their respective companies.

© 2019, Microchip Technology Incorporated, All Rights Reserved.  
ISBN: 978-1-5224-4491-6



# MICROCHIP

## Worldwide Sales and Service

### AMERICAS

**Corporate Office**  
2355 West Chandler Blvd.  
Chandler, AZ 85224-6199  
Tel: 480-792-7200  
Fax: 480-792-7277  
Technical Support:  
<http://www.microchip.com/support>  
Web Address:  
[www.microchip.com](http://www.microchip.com)

#### Atlanta

Duluth, GA  
Tel: 678-957-9614  
Fax: 678-957-1455

#### Austin, TX

Tel: 512-257-3370

#### Boston

Westborough, MA  
Tel: 774-760-0087  
Fax: 774-760-0088

#### Chicago

Itasca, IL  
Tel: 630-285-0071  
Fax: 630-285-0075

#### Dallas

Addison, TX  
Tel: 972-818-7423  
Fax: 972-818-2924

#### Detroit

Novi, MI  
Tel: 248-848-4000

#### Houston, TX

Tel: 281-894-5983

#### Indianapolis

Noblesville, IN  
Tel: 317-773-8323  
Fax: 317-773-5453  
Tel: 317-536-2380

#### Los Angeles

Mission Viejo, CA  
Tel: 949-462-9523  
Fax: 949-462-9608  
Tel: 951-273-7800

#### Raleigh, NC

Tel: 919-844-7510

#### New York, NY

Tel: 631-435-6000

#### San Jose, CA

Tel: 408-735-9110  
Tel: 408-436-4270

#### Canada - Toronto

Tel: 905-695-1980  
Fax: 905-695-2078

### ASIA/PACIFIC

**Australia - Sydney**  
Tel: 61-2-9868-6733

**China - Beijing**  
Tel: 86-10-8569-7000

**China - Chengdu**  
Tel: 86-28-8665-5511

**China - Chongqing**  
Tel: 86-23-8980-9588

**China - Dongguan**  
Tel: 86-769-8702-9880

**China - Guangzhou**  
Tel: 86-20-8755-8029

**China - Hangzhou**  
Tel: 86-571-8792-8115

**China - Hong Kong SAR**  
Tel: 852-2943-5100

**China - Nanjing**  
Tel: 86-25-8473-2460

**China - Qingdao**  
Tel: 86-532-8502-7355

**China - Shanghai**  
Tel: 86-21-3326-8000

**China - Shenyang**  
Tel: 86-24-2334-2829

**China - Shenzhen**  
Tel: 86-755-8864-2200

**China - Suzhou**  
Tel: 86-186-6233-1526

**China - Wuhan**  
Tel: 86-27-5980-5300

**China - Xian**  
Tel: 86-29-8833-7252

**China - Xiamen**  
Tel: 86-592-2388138

**China - Zhuhai**  
Tel: 86-756-3210040

### ASIA/PACIFIC

**India - Bangalore**  
Tel: 91-80-3090-4444

**India - New Delhi**  
Tel: 91-11-4160-8631

**India - Pune**  
Tel: 91-20-4121-0141

**Japan - Osaka**  
Tel: 81-6-6152-7160

**Japan - Tokyo**  
Tel: 81-3-6880-3770

**Korea - Daegu**  
Tel: 82-53-744-4301

**Korea - Seoul**  
Tel: 82-2-554-7200

**Malaysia - Kuala Lumpur**  
Tel: 60-3-7651-7906

**Malaysia - Penang**  
Tel: 60-4-227-8870

**Philippines - Manila**  
Tel: 63-2-634-9065

**Singapore**  
Tel: 65-6334-8870

**Taiwan - Hsin Chu**  
Tel: 886-3-577-8366

**Taiwan - Kaohsiung**  
Tel: 886-7-213-7830

**Taiwan - Taipei**  
Tel: 886-2-2508-8600

**Thailand - Bangkok**  
Tel: 66-2-694-1351

**Vietnam - Ho Chi Minh**  
Tel: 84-28-5448-2100

### EUROPE

**Austria - Wels**  
Tel: 43-7242-2244-39  
Fax: 43-7242-2244-393

**Denmark - Copenhagen**  
Tel: 45-4450-2828  
Fax: 45-4485-2829

**Finland - Espoo**  
Tel: 358-9-4520-820

**France - Paris**  
Tel: 33-1-69-53-63-20  
Fax: 33-1-69-30-90-79

**Germany - Garching**  
Tel: 49-8931-9700

**Germany - Haan**  
Tel: 49-2129-3766400

**Germany - Heilbronn**  
Tel: 49-7131-67-3636

**Germany - Karlsruhe**  
Tel: 49-721-625370

**Germany - Munich**  
Tel: 49-89-627-144-0  
Fax: 49-89-627-144-44

**Germany - Rosenheim**  
Tel: 49-8031-354-560

**Israel - Ra'anana**  
Tel: 972-9-744-7705

**Italy - Milan**  
Tel: 39-0331-742611  
Fax: 39-0331-466781

**Italy - Padova**  
Tel: 39-049-7625286

**Netherlands - Drunen**  
Tel: 31-416-690399  
Fax: 31-416-690340

**Norway - Trondheim**  
Tel: 47-7288-4388

**Poland - Warsaw**  
Tel: 48-22-3325737

**Romania - Bucharest**  
Tel: 40-21-407-87-50

**Spain - Madrid**  
Tel: 34-91-708-08-90  
Fax: 34-91-708-08-91



**Sweden - Gothenberg**  
Tel: 46-31-704-60-40

**Sweden - Stockholm**  
Tel: 46-8-5090-4654

**UK - Wokingham**  
Tel: 44-118-921-5800  
Fax: 44-118-921-5820

## Looking for pricing, stock, or lifecycle information?

Click below to explore more details on WIN SOURCE:

-  [View PIC24FJ128GA106-E/MR on WIN SOURCE](#)
-  [Microchip Technology](#) Information

## Optimize Your Supply Chain with WIN SOURCE Solutions

-  Global Sourcing Solution
-  Obsolete Management
-  Cost Control Management
-  Shortage Management
-  Alternative Solution
-  Excess Inventory Management