



**THE DATASHEET OF  
ESC-120002020B20-02**



Jiangsu Everstar Electronics Co., Ltd.

**Address:**No.6 Xiangshan Rd, Tianmuhu Industry Park, Liyang City, Jiangsu Province, China

**TEL:** +86-519-87557772

**FAX:** +86-519-87557773

**Http:** www.everstarelect.com

## DATA SHEET

ESL NO.. : ESC-120002020B20-02

CUS NO. :

REV : A / 0

Producer: Eden

Auditor: \_\_\_\_\_

Approver: Jack

CUSTOMER'S APPROVAL : \_\_\_\_\_

DCC : \_\_\_\_\_

# HC-49/S Quartz Crystal

ESC-120002020B20-02

REV:A / 0

## Package Outline Dimensions

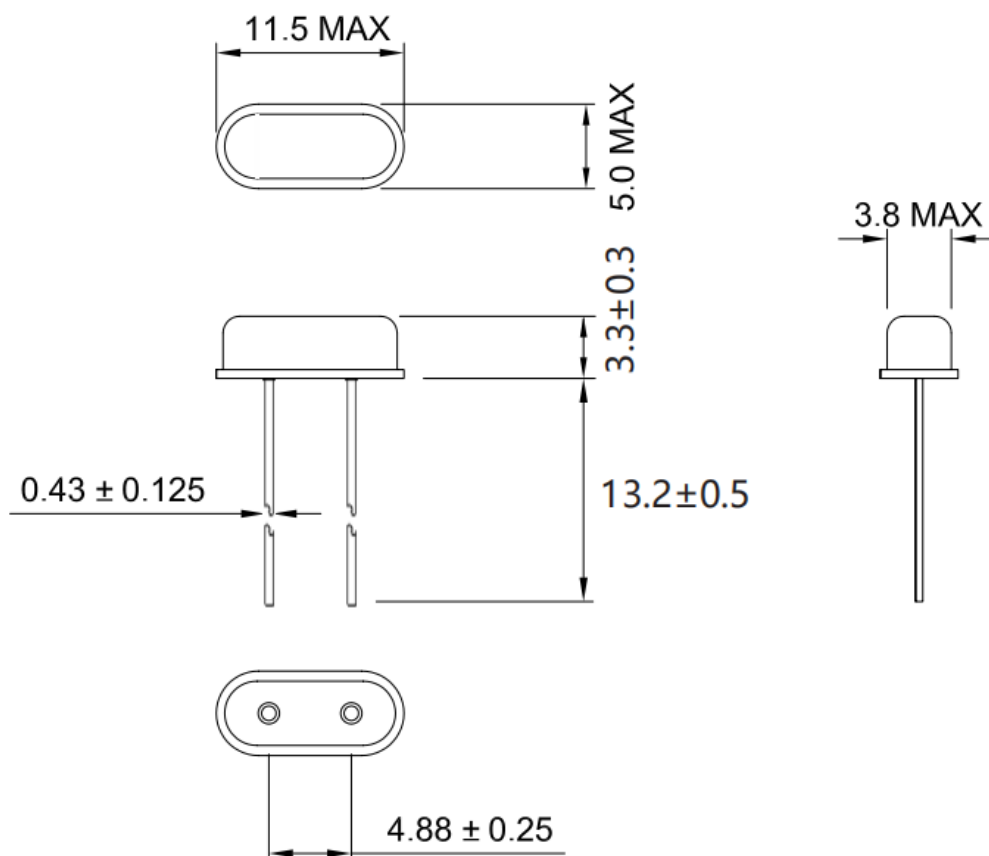

## Package Information

200PCS/Plastic Bag

1000PCS/Ammopack

20Box/Carton

# HC-49/S Quartz Crystal

ESC-120002020B20-02

REV:A / 0

## 1. Scope:

- 1.1 This specification applies to the RoHS/HF compliance quartz crystal unit with a frequency of 12MHz which will be used in crystal oscillator applications.

## 2. Construction:

- 2.1 Type of Quartz Resonator: HC-49/S

## 3. Electrical Characteristics

- |   |                         |
|---|-------------------------|
| 3.1 Nominal Frequency(f):                     | 12MHz                   |
| 3.2 Load Capacitance( $C_L$ ):                | 20pF                    |
| 3.3 Frequency Tolerance( $\Delta f/f$ ):      | $\pm 20$ ppm            |
| 3.4 Frequency Temperature Stability:          | $\pm 20$ ppm(Ref.@25°C) |
| 3.5 Resonance Resistance(ohm):                | 40ohms Max              |
| 3.6 Osc mode:                                 | Fundamental mode        |
| 3.7 Shunt Capacitance( $C_0$ ):               | <7pF                    |
| 3.8 Drive Level( $D_L$ ):                     | <300 $\mu$ W            |
| 3.9 Operating Temperature Range( $T_{OPR}$ ): | -40 to + 85°C           |
| 3.10 Storage Temperature Range( $T_{STG}$ ):  | -55 to + 125°C          |
| 3.11 Insulation Resistance(IR):               | >500 M ohms             |
| 3.12 Aging( $\Delta f_A$ ):                   | $\pm 3$ ppm per Year    |

# HC-49/S Quartz Crystal

## ESC-120002020B20-02

REV:A / 0

### 4. Reliability Specifications

This is the quality control and quality assurance and reliability tests performance data for the RoHS/ HF compliance 12MHz HC-49/S Quartz Crystal .

related to the specification and approval sheet provided by JSCJ .

Standard test condition (TEMP.: 20±5°C. Relative humidity: 65±20%)

For any discrepancy in GO/NG, test will be done at TEMP.25±2°C, R.H. 65±5%.

NO.	PROCESS	SPECIFICATION	TEST METHOD
4.1	Temperature Cycle (GB/T 2423.22-2002, Method Nb)	Frequency change after test $\leq \pm 5$ ppm. Resonance resistance change after test $\leq 10$ ohms.	10 cycles from -55°C to 125°C. Measurement taken after DUT being left at room temperature for 24±2 hours.
4.2	Low Temperature Storage (GB/T 2423.1-2001, Method Aa)	Frequency change after test $\leq \pm 5$ ppm. Resonance resistance change after test $\leq 10$ ohms.	Spending 72 hrs at -55°C±3°C constant temperature. Measurement taken after DUT being left at room temperature for 24±2 hours.
4.3	High Temperature Storage (GB/T 2423.2-2001, Method Ba)	Frequency change after test $\leq \pm 5$ ppm. Resonance resistance change after test $\leq 10$ ohms.	Spending 72 hrs at 125°C±3°C constant temperature. Measurement taken after DUT being left at room temperature for 24±2 hours.
4.4	Humidity (GB/T 2423.3-2006, Method Cab)	Frequency change after test $\leq \pm 5$ ppm. Resonance resistance change after test $\leq 10$ ohms.	Spending 96 hrs at 40 °C ± 3 °C, with 93 %R.H, Then keep the DUT in dry oven at 40 ± 5 °C for 24 hour. Measurement taken after DUT being left at room temperature for 1 to 2 hours.
4.5	Vibration (GB/T 2423.10-1995, Method Fc)	Frequency change after test $\leq \pm 5$ ppm. Resonance resistance change after test $\leq 10$ ohms.	Apply 0.75mm vibration at sweep frequency 10~500 Hz, 10 cycles in each direction of 3 axis. Measurement taken after 1 hour.
4.6	Shock (GB/T 2423.5-1995, Method Ea)	Frequency change after test $\leq \pm 5$ ppm. Resonance resistance change after test $\leq 10$ ohms. and exhibit no visible damage.	Peak 1000m/s <sup>2</sup> , normal width 6ms half sine wave form, 3.7m/s, 3 perpendicular axis of samples, 3 cycles / direction, total 18 cycles. Measurement taken after 1 hour.
4.7	Drop (GB/T 2423.8-1995, Method Ed)	Frequency change after test $\leq \pm 5$ ppm. Resonance resistance change after test $\leq 10$ ohms. and exhibit no visible damage.	Free drop to the steel plate with thickness of 3 mm from 1.00 m heights for 3 times.
4.8	Solderability ( IEC60068-2-58, Test Td:)	Terminals shall be covered more then 95% with solder.	Passed through the re-flow oven under the following condition. Preheat 150 to 180°C for 60 to 120sec, and soldering time for 20s ± 5s at 235°C, peak soldering time for 10s ± 1s between 240 and 250°C. There is no need to do functional test. 8-12X magnifier.
4.9	Terminal Strength (JIS-C-6429 Method 1 & 2 )	No visible damage	Mount on a glass-epoxy board (100x50x1.6mm), then bend to 2mm displacement (velocity 1mm/sec) and keep for 5 seconds. or pulling force 1.8kg for at least 60 seconds.
4.10	Resistance to Soldering Heat (IEC60068-2-58, Test Td: Table 4)	Frequency change after test $\leq \pm 5$ ppm. Resonance resistance change after test $\leq 10$ ohms.	Passed through the re-flow oven under the following condition. Preheat 150 to 180°C for 60 to 120sec, and soldering time for 60s max at 235°C, peak soldering time for 20s max at 265°C max. Measurement taken after DUT being left at room temperature for at least 2 hours.
4.11	OTHERS		

Notes : The above test items and judgment standards are for reference only, and the actual reliability report shall prevail.

5. Recommended Reflow soldering condition (SMD)

Solder profile

Peak:  $260 \pm 5^\circ\text{C}$  Soldering zone:  $230^\circ\text{C}$  or more,  $30 \pm 10\text{s}$ . Pre-heating zone 1:  $150 \sim 180^\circ\text{C}$ ,  $90 \pm 30\text{s}$

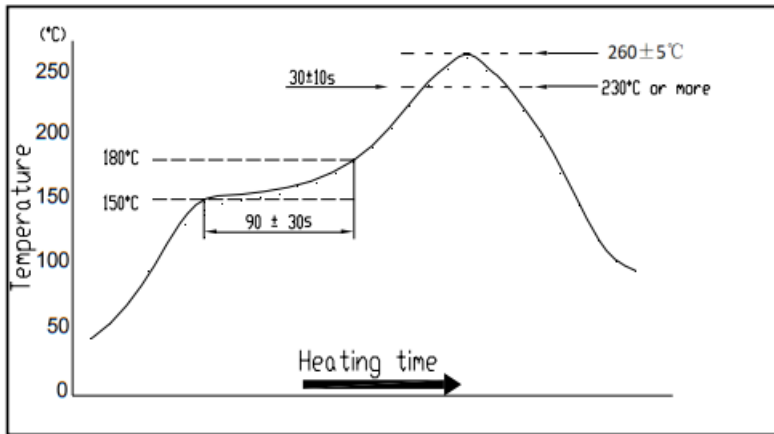

Temperature profile for reflow soldering

6. Soldering iron method

Bit temperature:  $350 \pm 10^\circ\text{C}$  Application time of soldering iron:  $3+1\text{ s}$ . For other procedures, refer to IEC 60068-2-20.

## Looking for pricing, stock, or lifecycle information?

Click below to explore more details on WIN SOURCE:

- [View ESC-120002020B20-02 on WIN SOURCE](#)
- [Shanghai Everstar Electronics Co., Ltd. Information](#)

## Optimize Your Supply Chain with WIN SOURCE Solutions

- ✓ Global Sourcing Solution
- ✓ Obsolete Management
- ✓ Cost Control Management
- ✓ Shortage Management
- ✓ Alternative Solution
- ✓ Excess Inventory Management