



**THE DATASHEET OF
ESS-3535CLFB455**





Jiangsu Everstar Electronics Co., Ltd.

Address:No.6 Xiangshan Rd, Tianmuhu Industry Park, Liyang City, Jiangsu Province, China

TEL: +86-519-87557772

FAX: +86-519-87557773

Http: www.everstarelect.com

DATA SHEET

ESL NO.. : ESS-3535CLFB455

CUS NO. :

REV : A / 0

Producer: Eden Auditor: _____ Approver: Jack

CUSTOMER'S APPROVAL : _____ DCC : _____

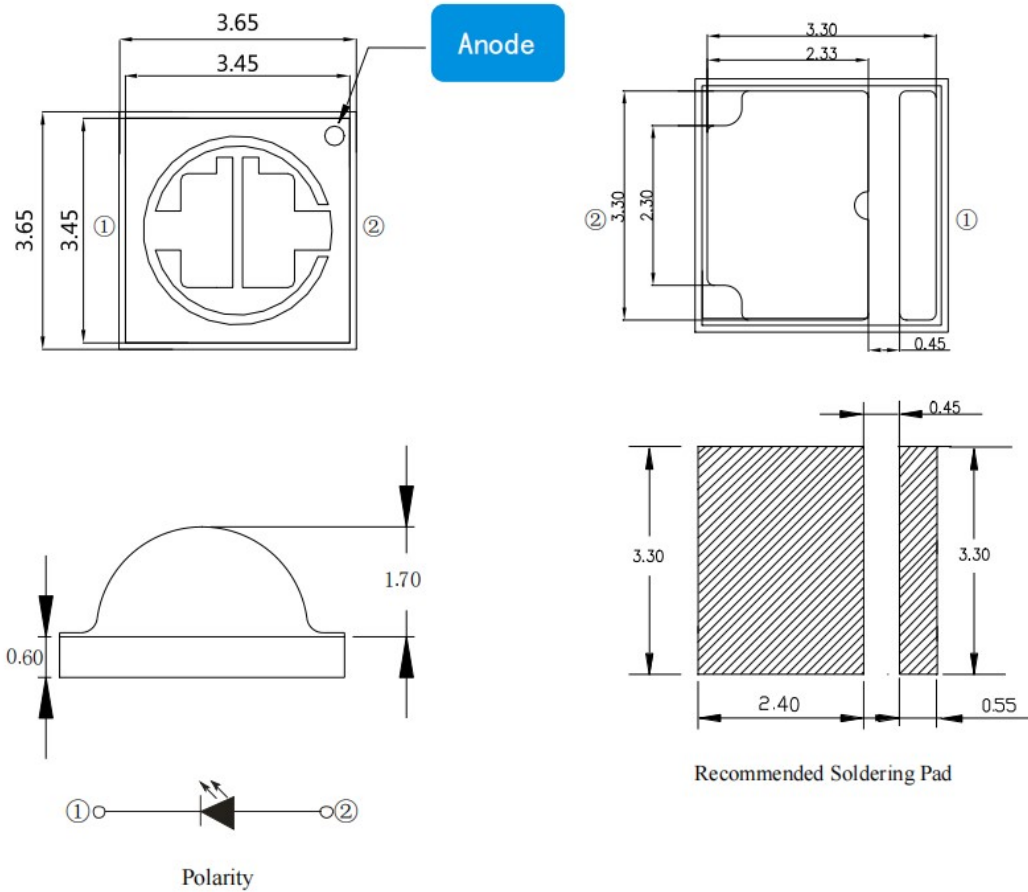

Note:

All Dimensions are in millimeters.



3535 SMD LED

ESS-3535CLFB455

REV:A /0

FEATURES

- * 3535 SMD LED
- * Low operating voltage
- * PB Free products (Compliant with EU's RoHS)
- * Ceramics
- * High reliability
- * Low power consumption, long life

CHIP MATERIALS:

- * Dice Material : InGaN
- * Light Color: Blue
- * Lens Color: Water Clear

APPLICATIONS

- * Agriculture & Horticulture
- * Indoor Lighting
- * Entertainment



3535 SMD LED

ESS-3535CLFB455

REV:A /0

ABSOLUTE MAXIMUM RATING : (Ta = 25°C)

Symbol	DESCRIPTION	Rated	Unit
Topr	Operating Temperature Range	-40°C ~ +105°C	
Tstg	Storage Temperature Range	-40°C ~ +105°C	
VR	Reverse Voltage Per Chip	5	V
ESD	Electro-Static discharge	2	kV
IF	Average Forward Current Per Chip	1000	mA
IFp	Peak Forward Current Per Chip	2000	mA

ELECTRO-OPTICAL CHARACTERISTICS : (Ta = 25°C)

SYMBOL	PARAMETER	TEST CONDITION	MIN.	TYP	MAX	UNIT
VF	Forward Voltage	IF = 350mA	2.6		3.2	V
2θ 1/2	Half Intensity Angle	IF = 350mA	----	120	----	deg
IR	Reverse Current	VR = 5V	----	----	1	μA
λ P	Peak Wavelength	IF = 350mA	450		460	nm
PPF	Photosynthetic Photon Flux	IF = 350mA	2.8		3.2	μmol/s
RP	Radiant Power	IF = 350mA	750		850	mW
PAR	Photosynthetic Active Radiation	IF = 350mA	740		820	mW



3535 SMD LED

ESS-3535CLFB455

REV:A /0

SPECTRUM CHART

Spectrum Distribution (IF = 350 mA, Ts = 25°C)

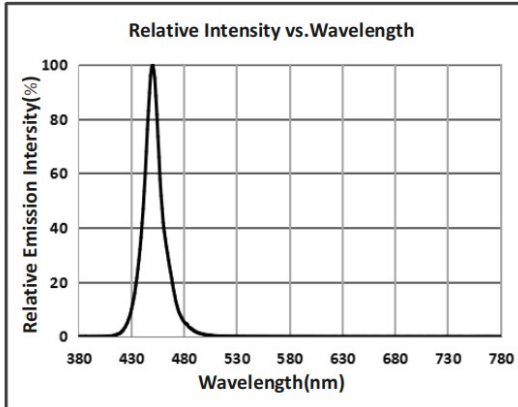

Temperature Characteristics (IF = 350 mA)

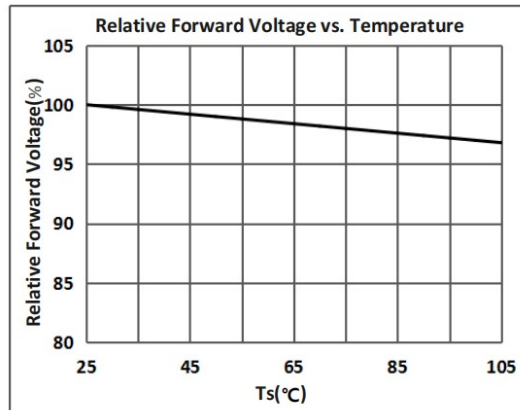
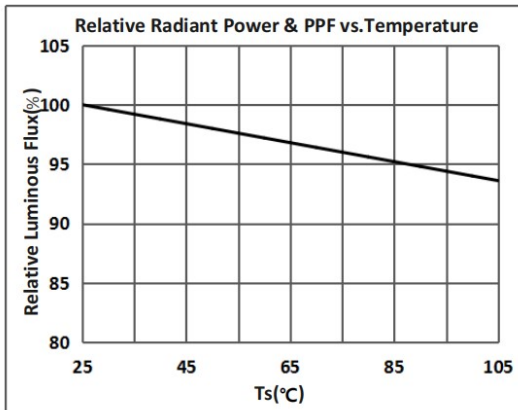

Forward Current Characteristics (Ts = 25°C)

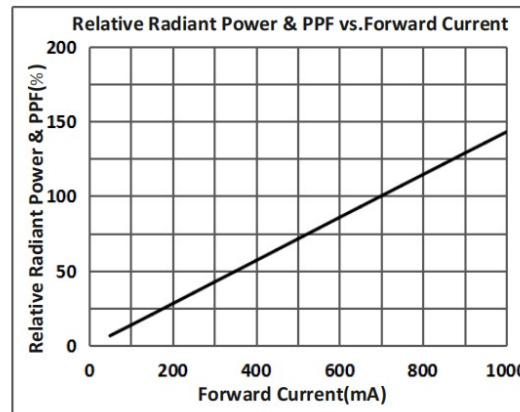
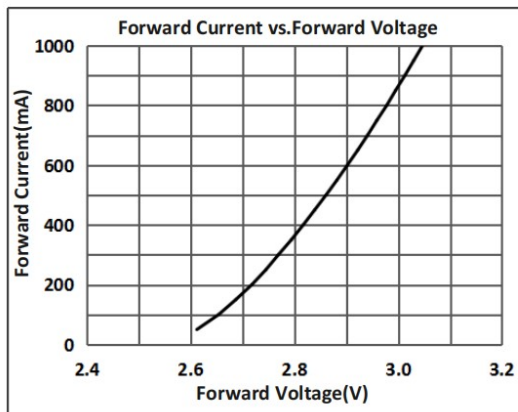



3535 SMD LED

ESS-3535CLFB455

REV:A /0

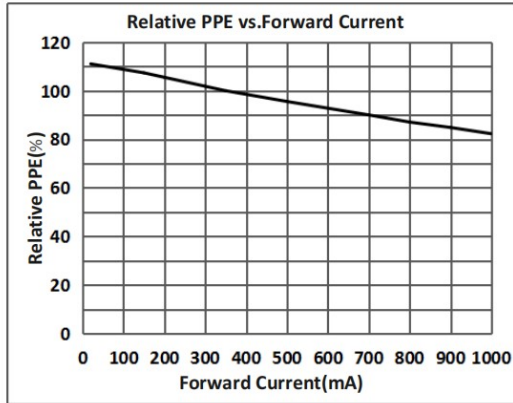

Color Shift Characteristics, $T_s = 25^\circ\text{C}$

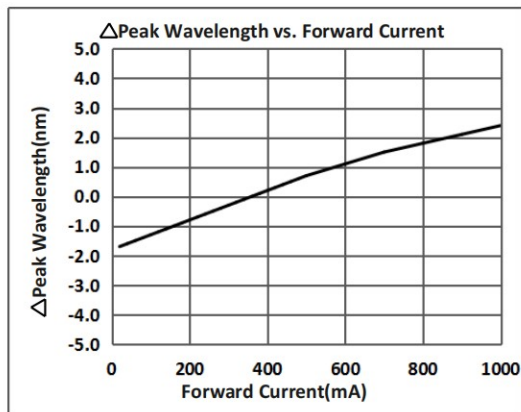

Derating Curve

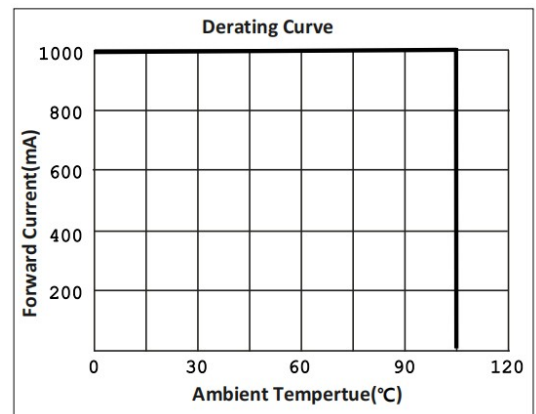

Beam Angle Characteristics ($T_s = 25^\circ\text{C}$, $I_F = 350\text{ mA}$)

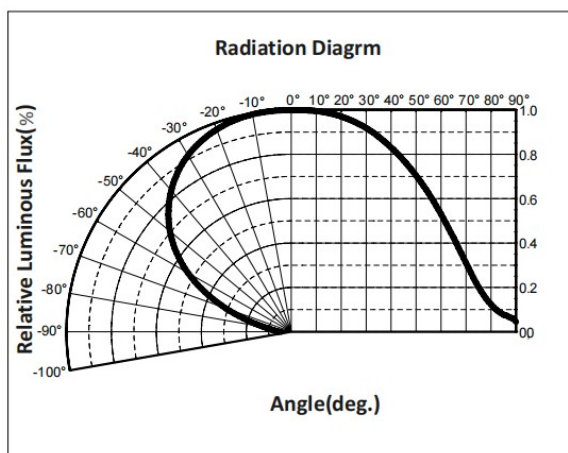



3535 SMD LED

ESS-3535CLFB455

REV:A /0

BIN NAMEING (IF=350mA Ta =25°C)

Voltage BIN		Forward Voltage(V)
A	A1	2.6-2.7
	A2	2.7-2.8
B	B1	2.8-2.9
	B2	2.9-3.0
C	C1	3.0-3.1
	C2	3.1-3.2

WLD BIN	Peak Wavelength(nm)
W1	450-455
W2	455-460

PPE BIN	Radiant Power Range(mW)	PPE Range(μmol/J)
P1	750-800	2.8-3.0
P2	780-850	3.0-3.2



3535 SMD LED

ESS-3535CLFB455

REV:A /0

Package Tape Specifications: (1000 pcs/Reel)

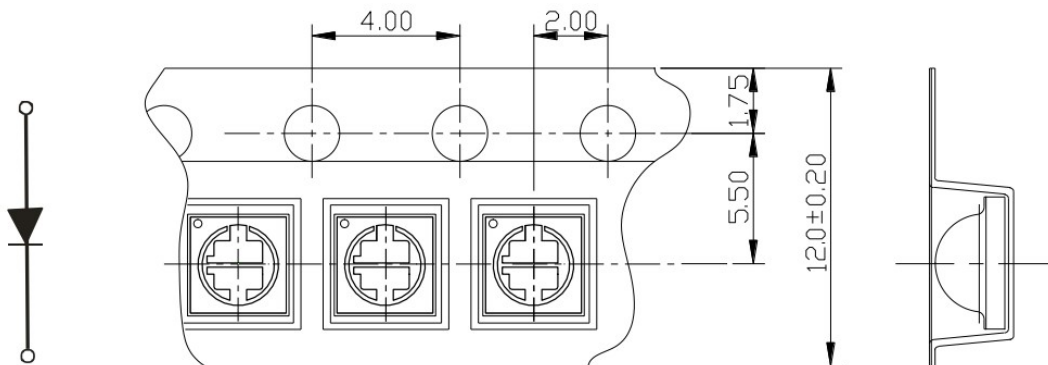
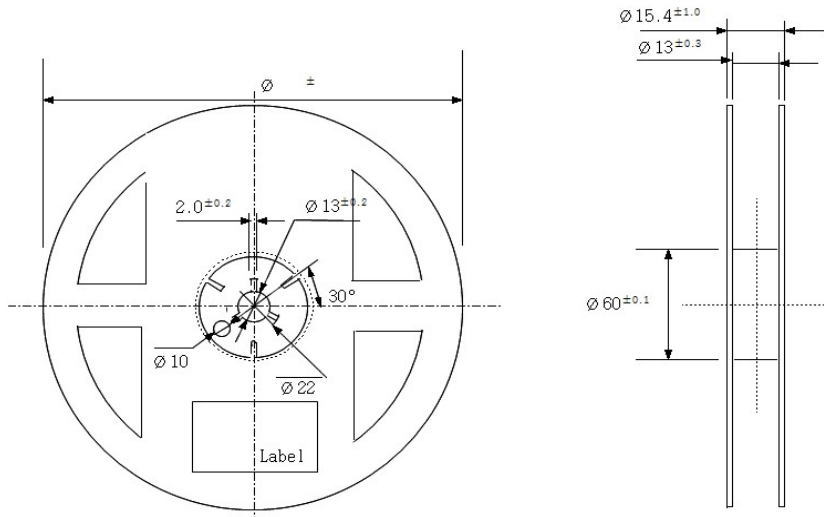



3535 SMD LED

ESS-3535CLFB455

REV:A /0

※ Precautions for use :

- 1) Customer must apply the current limiting resistor in the circuit so as to drive the LEDs within the rated current. Otherwise slight voltage shift maybe will cause big current change and burn out will happen.
- 2) Also, caution should be taken not to overload the LEDs with instantaneous high voltage at the turning ON and OFF of the circuit.
- 3) Storage:
 - a) 3.1 Don't open the moisture proof bag before ready to use the LEDs.
 - b) 3.2 The LEDs should be kept at 30°C or less and 60%RH or less before opening the package. The max. storage period before opening the package is 1 year.
 - c) 3.3 After opening the package, the LEDs should be kept at 30°C/35%RH or less, and it should be used within 7 days.
 - d) 3.4 If the LEDs be kept over the conditions of 3.4, baking is required before mounting.
Baking condition as below: $60 \pm 5^\circ\text{C}$ for 12 hrs.
- 4) Soldering condition:

4.1 Lead Solder:

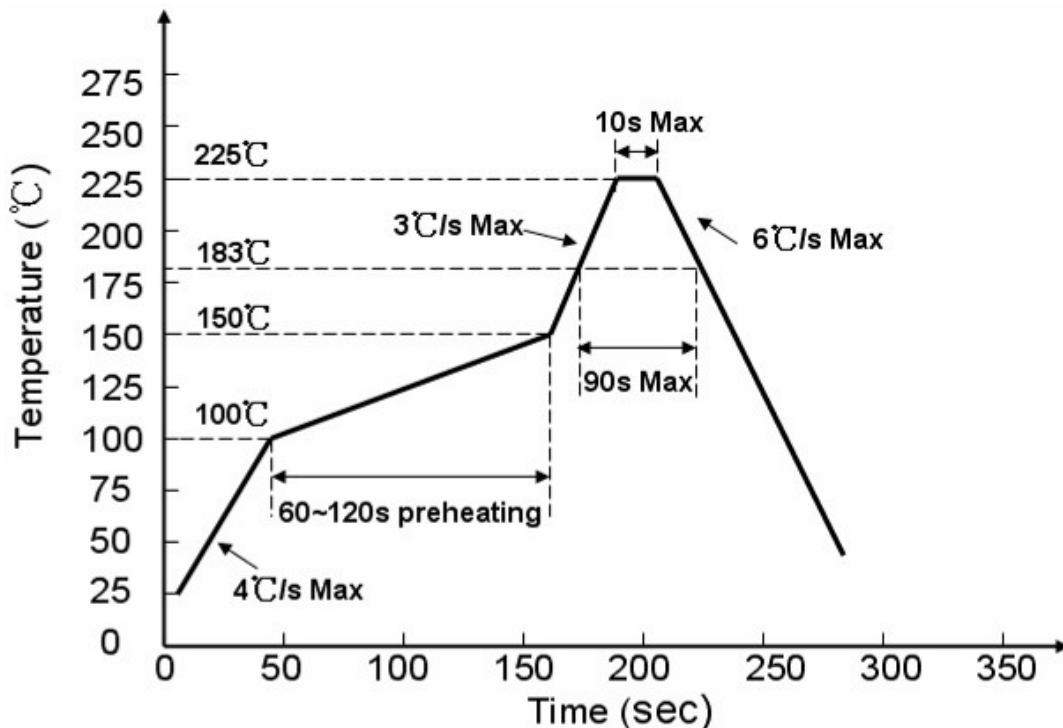

4.2 Lead Free Solder:

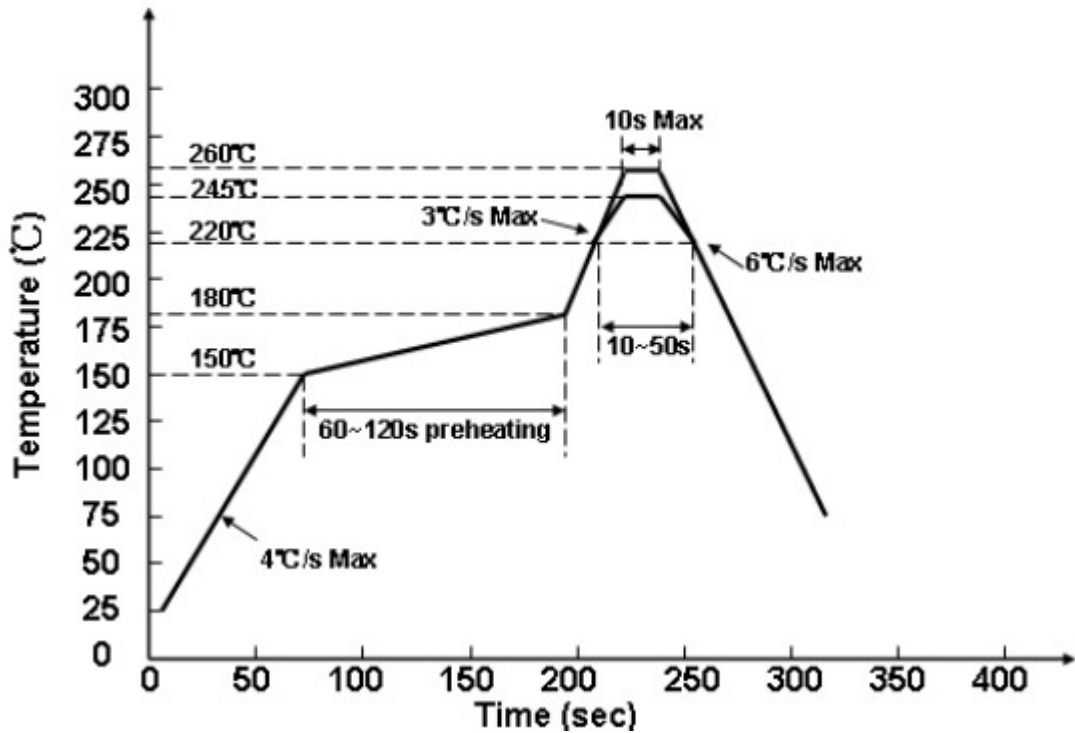

Note:

- 1.Reflow soldering should not be done more than two times.
2. Don't put stress on the LEDs when soldering.
- 3.Don't warp the circuit board before it have been returned to normal ambient conditions after soldering

Looking for pricing, stock, or lifecycle information?

Click below to explore more details on WIN SOURCE:

- [View ESS-3535CLFB455 on WIN SOURCE](#)
- [Shanghai Everstar Electronics Co., Ltd. Information](#)

Optimize Your Supply Chain with WIN SOURCE Solutions

- ✓ Global Sourcing Solution
- ✓ Obsolete Management
- ✓ Cost Control Management
- ✓ Shortage Management
- ✓ Alternative Solution
- ✓ Excess Inventory Management