



THE DATASHEET OF ESS-3528CWC





Jiangsu Everstar Electronics Co., Ltd.

Address:No.6 Xiangshan Rd, Tianmuhu Industry Park, Liyang City, Jiangsu Province, China

TEL: +86-519-87557772

FAX: +86-519-87557773

Http: www.everstarelect.com

DATA SHEET

ESL NO.. : ESS-3528CWC

CUS NO. :

REV : A / 0

Producer: Eden Auditor: _____ Approver: Jack

CUSTOMER'S APPROVAL : _____ DCC : _____

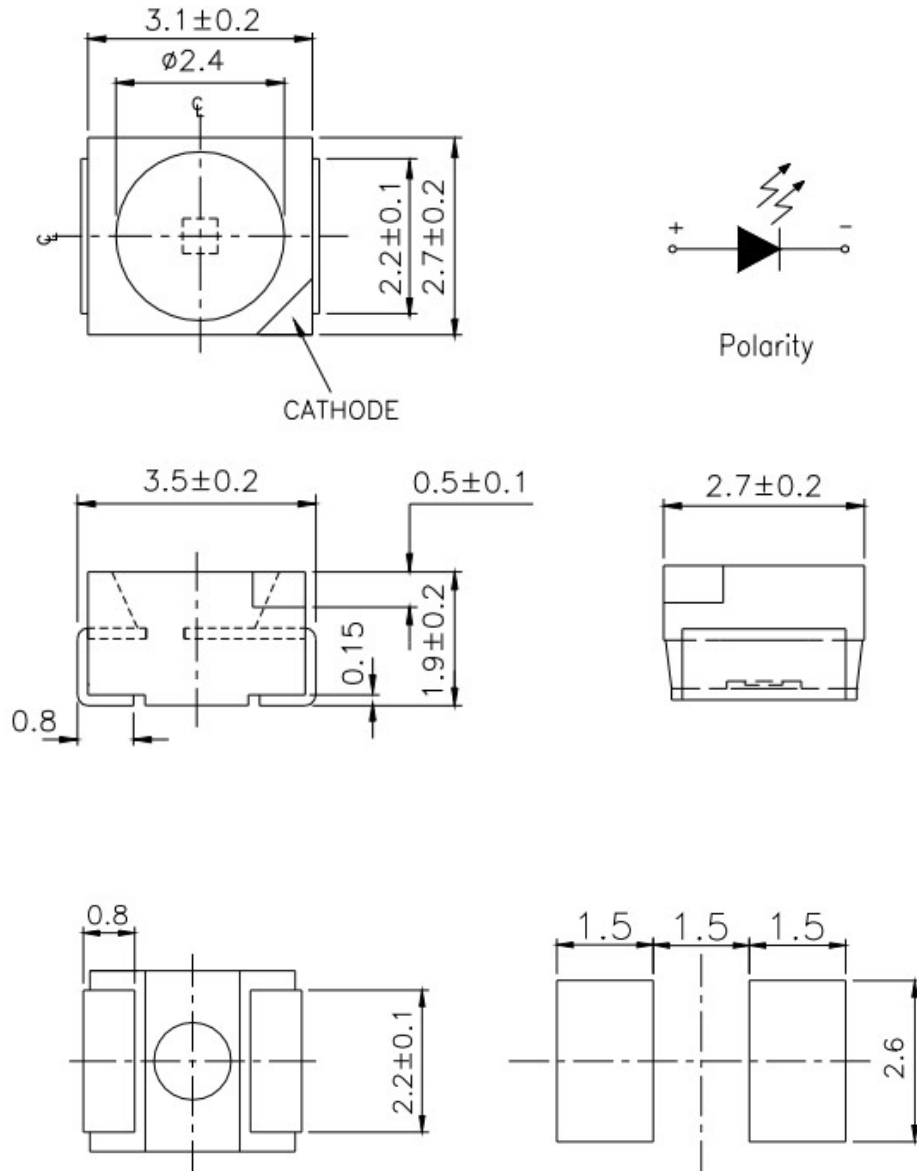

Note:

All Dimensions are in millimeters.



3528 SMD LED

ESS-3528CWC

REV:A /0

FEATURES

- * 3528 SMD LED
- * Low operating voltage
- * PB Free products (Compliant with EU's RoHS)
- * High reliability
- * Low power consumption, long life

CHIP MATERIALS:

- * Dice Material : GaInN
- * Lens Color: Yellow
- * Light Color: White



3528 SMD LED

ESS-3528CWC

REV:A /0

ABSOLUTE MAXIMUM RATING : (Ta = 25°C)

Symbol	DESCRIPTION	Rated	Unit
Topr	Operating Temperature Range	-40°C ~ +85°C	
Tstg	Storage Temperature Range	-40°C ~ +100°C	
VR	Reverse Voltage Per Chip	5	V
PD	Power Dissipation Per Chip	120	mW
IF	Average Forward Current Per Chip	30	mA
IFp	Peak Forward Current Per Chip	100	mA

ELECTRO-OPTICAL CHARACTERISTICS : (Ta = 25°C)

SYMBOL	PARAMETER	TEST CONDITION	MIN.	TYP	MAX	UNIT
VF	Forward Voltage	IF = 20mA	2.8		3.4	V
IF	Peak Forward Current	VF=3.0V	1.0		20	mA
X	Chromaticity Coordinate	IF = 20mA		0.305		
Y		IF = 20mA		0.295		
2θ 1/2	Half Intensity Angle	IF = 20mA	----	120	----	deg
IV	Luminous Intensity	IF = 20mA	1800		3200	mcd
IR	Reverse Current	VR = 5V	----	----	5	μA
ESD	Electro-Static discharge	IF = 20mA			2000	v



3528 SMD LED

ESS-3528CWC

REV:A /0

SPECTRUM CHART

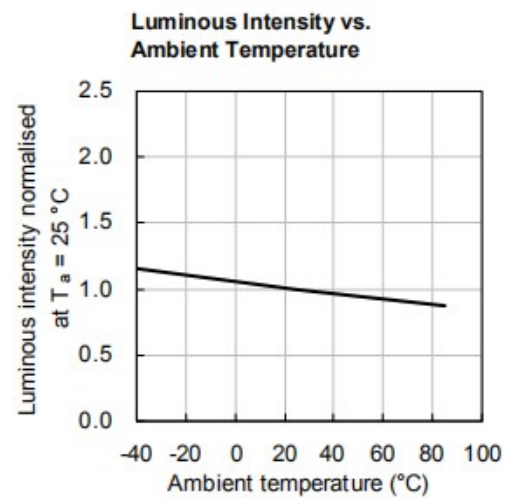
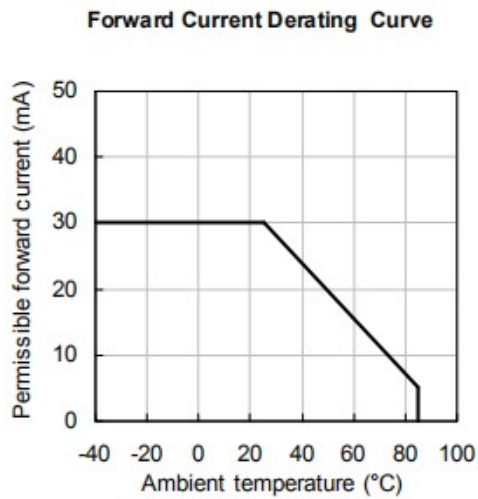
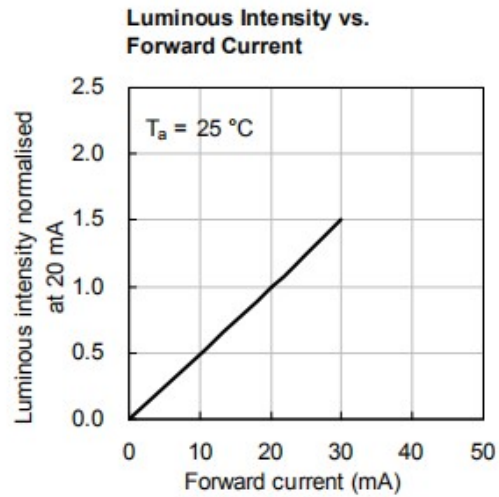
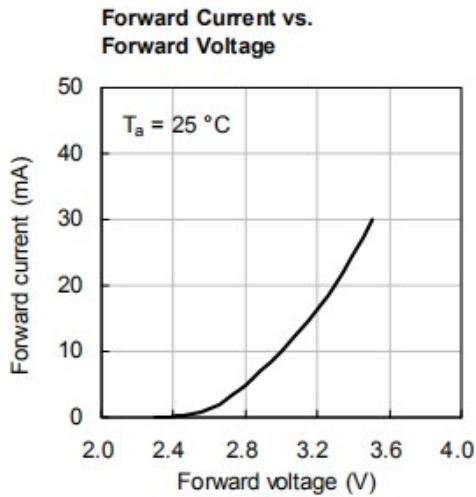

SPATIAL DISTRIBUTION

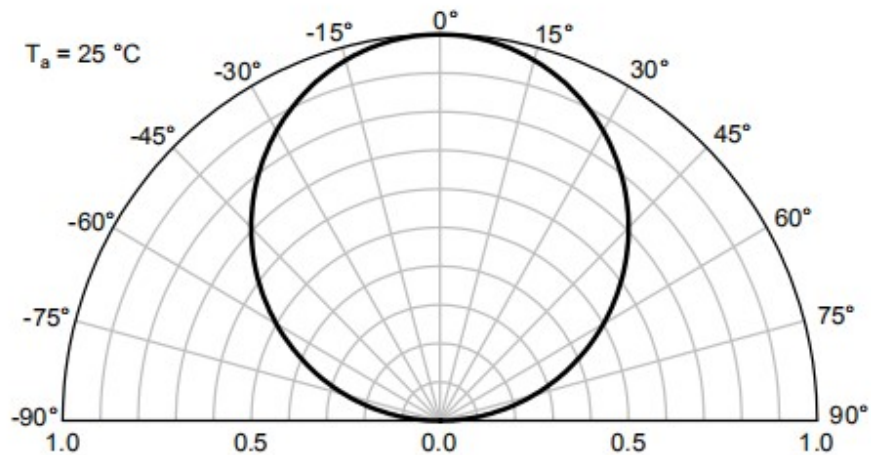



3528 SMD LED

ESS-3528CWC

REV:A /0

BIN NAMEING

Luminous Intensity Rank Combination (IF=20mA)

BIN	Luminous Intensity(mcd)
1	1800-2500
2	2500-3200

Forward Voltage Rank Combination (IF=20mA)

BIN	Forward Voltage(V)
A	2.8-2.9
B	2.9-3.0
C	3.0-3.1
D	3.1-3.2
E	3.2-3.3
F	3.3-3.4



3528 SMD LED

ESS-3528CWC

REV:A /0

Color Chromaticity Groups

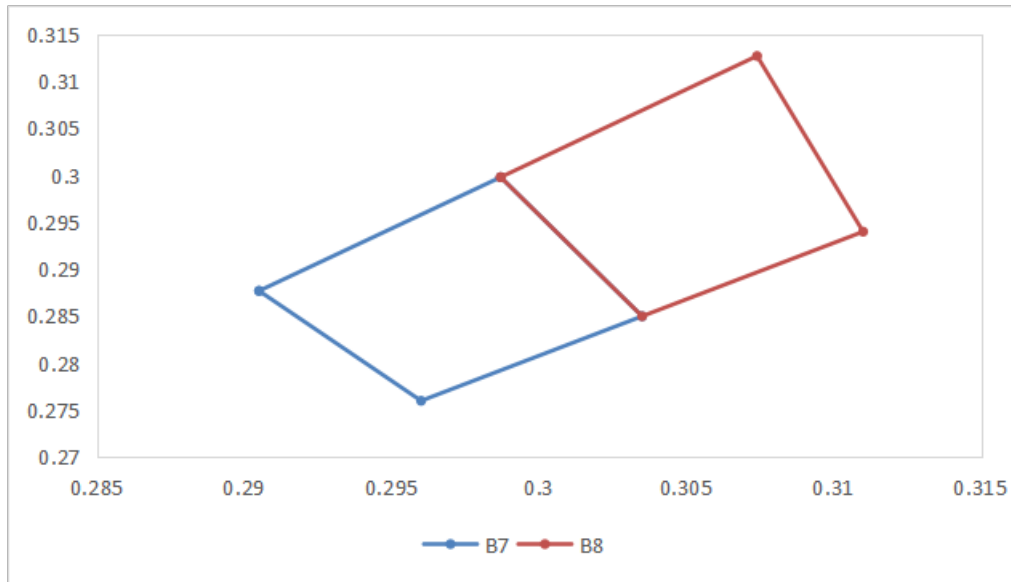

B7		B8	
X	Y	X	Y
0.2905	0.2877	0.2987	0.2998
0.2987	0.2998	0.3074	0.3127
0.3035	0.2850	0.3110	0.2940
0.2960	0.2760	0.3035	0.2850



3528 SMD LED

ESS-3528CWC

REV:A /0

Package Tape Specifications: (2000 pcs/Reel)

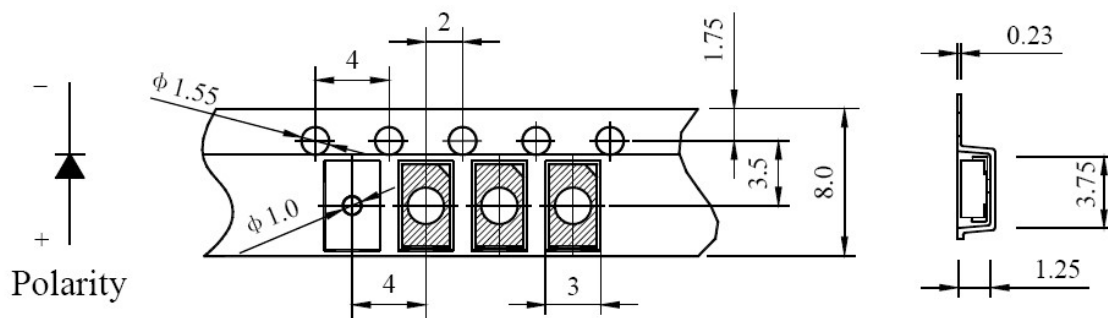
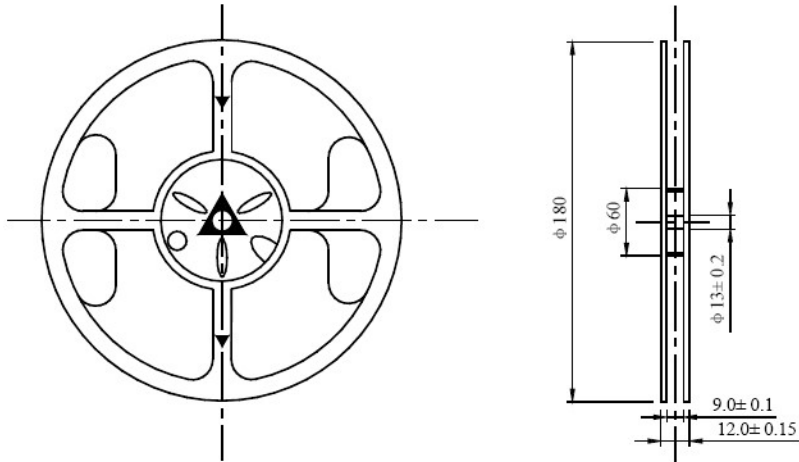



3528 SMD LED

ESS-3528CWC

REV:A /0

※ Precautions for use :

- 1) Customer must apply the current limiting resistor in the circuit so as to drive the LEDs within the rated current. Otherwise slight voltage shift maybe will cause big current change and burn out will happen.
- 2) Also, caution should be taken not to overload the LEDs with instantaneous high voltage at the turning ON and OFF of the circuit.
- 3) Storage:
 - a) 3.1 Don't open the moisture proof bag before ready to use the LEDs.
 - b) 3.2 The LEDs should be kept at 30°C or less and 60%RH or less before opening the package. The max. storage period before opening the package is 1 year.
 - c) 3.3 After opening the package, the LEDs should be kept at 30°C/35%RH or less, and it should be used within 7 days.
 - d) 3.4 If the LEDs be kept over the conditions of 3.4, baking is required before mounting.
Baking condition as below: $60 \pm 5^\circ\text{C}$ for 12 hrs.
- 4) Soldering condition:

4.1 Lead Solder:

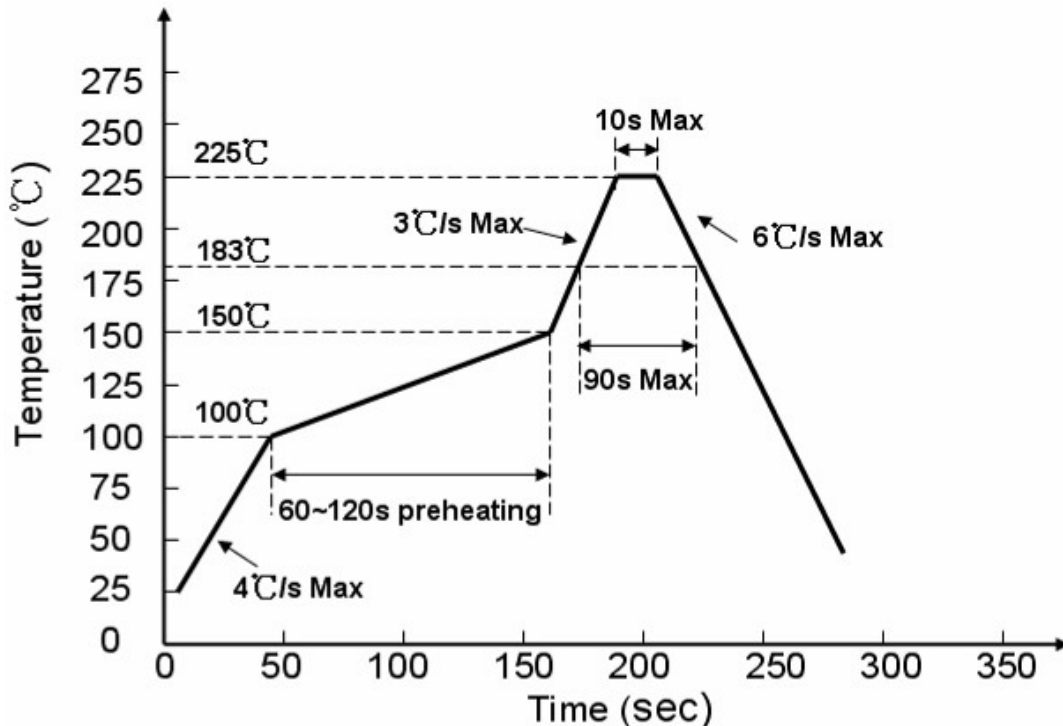

4.2 Lead Free Solder:

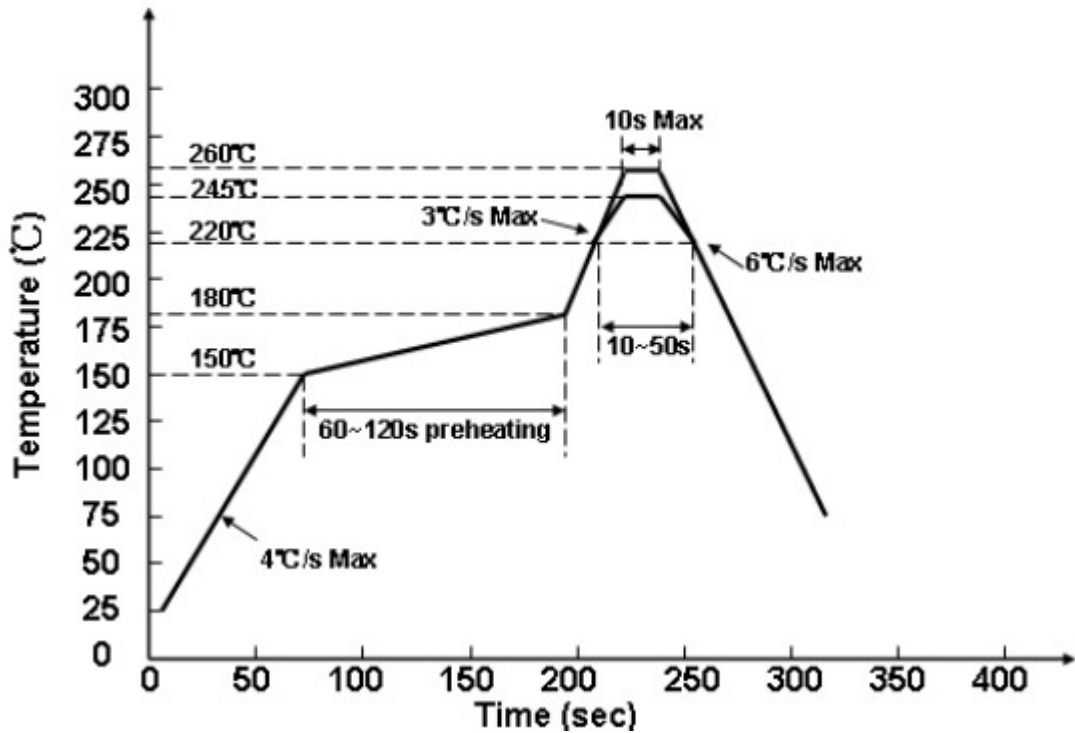

Note:

- a) 1.Reflow soldering should not be done more than two times.
- b) 2. Don't put stress on the LEDs when soldering.
- c) 3.Don't warp the circuit board before it have been returned to normal ambient conditions after soldering

Looking for pricing, stock, or lifecycle information?

Click below to explore more details on WIN SOURCE:

- ⊖ [View ESS-3528CWC on WIN SOURCE](#)
- ⊖ [Shanghai Everstar Electronics Co., Ltd. Information](#)

Optimize Your Supply Chain with WIN SOURCE Solutions

- ✓ Global Sourcing Solution
- ✓ Obsolete Management
- ✓ Cost Control Management
- ✓ Shortage Management
- ✓ Alternative Solution
- ✓ Excess Inventory Management