



**THE DATASHEET OF
ESS-2214TWD-J**



Jiangsu Everstar Electronics Co., Ltd.

Address:No.6 Xiangshan Rd, Tianmuhu Industry Park, Liyang City, Jiangsu Province, China

TEL: +86-519-87557772

FAX: +86-519-87557773

Http: www.everstarelect.com

DATA SHEET

ESL NO.. : ESS-2214TWD-J

CUS NO. :

REV : A / 0

Producer: _____

Eden

Auditor: _____

Approver: _____

Jack

CUSTOMER'S APPROVAL : _____

DCC : _____

2214 SMD LED

ESS-2214TWD-J

REV:A/0

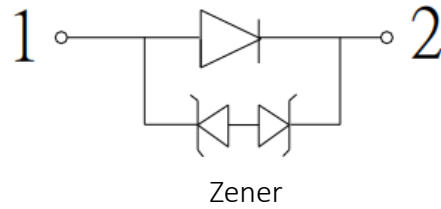
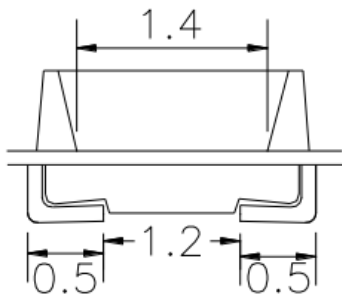
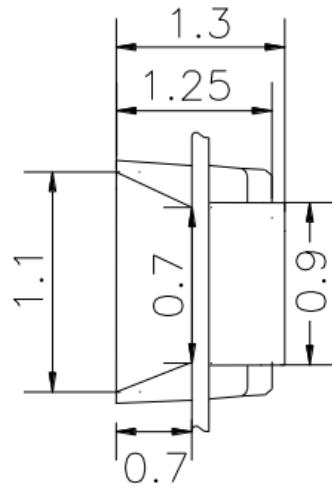
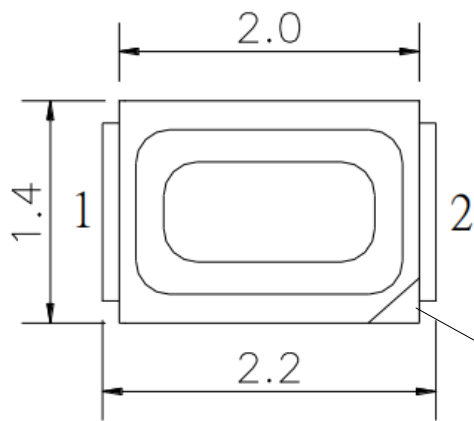

Note:

All Dimensions are in millimeters.

2214 SMD LED

ESS-2214TWD-J

REV:A /0

FEATURES

- * 2214 SMD LED
- * High reliability
- * Low operating voltage
- * Low power consumption, long life
- * PB Free products (Compliant with EU's RoHS)

CHIP MATERIALS:

- * Dice Material : InGaN
- * Light Color: White
- * Lens Color: Yellow

2214 SMD LED

ESS-2214TWD-J

REV:A /0

ABSOLUTE MAXIMUM RATING : (Ta = 25°C)

Symbol	DESCRIPTION	Rated	Unit
Topr	Operating Temperature Range	-30°C ~ +85°C	
Tstg	Storage Temperature Range	-40°C ~ +100°C	
VR	Reverse Voltage Per Chip	5	V
PD	Power Dissipation Per Chip	120	mW
IF	Average Forward Current Per Chip	30	mA
IFp	Peak Forward Current Per Chip	100	mA

ELECTRO-OPTICAL CHARACTERISTICS : (Ta = 25°C)

SYMBOL	PARAMETER	TEST CONDITION	MIN.	TYP	MAX	UNIT
VF	Forward Voltage	IF = 10mA	2.6		3.2	V
IF	Peak Forward Current	VF=3.0V	1.0		20	mA
2 θ 1/2	Half Intensity Angle	IF = 10mA	----	120	----	deg
IV	Luminous Intensity	IF = 10mA		100		mcd
IR	Reverse Current	VR = 5V	----	----	5	μA
CCT	Color Temperature	IF = 10mA		5800		K
X	Chromaticity Coordinate	IF = 10mA		0.330		
Y		IF = 10mA		0.345		
ESD	Electro-Static discharge	IF = 10mA		8000		v

2214 SMD LED

ESS-2214TWD-J

REV:A /0

SPECTRUM CHART

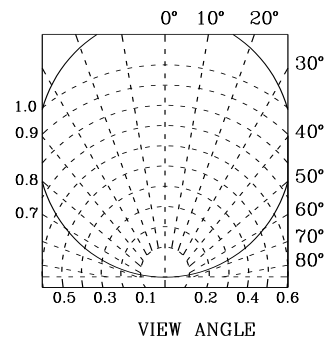
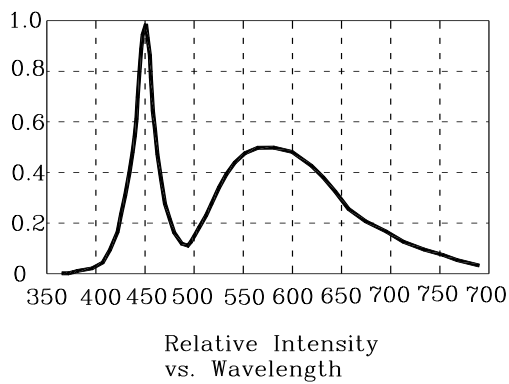
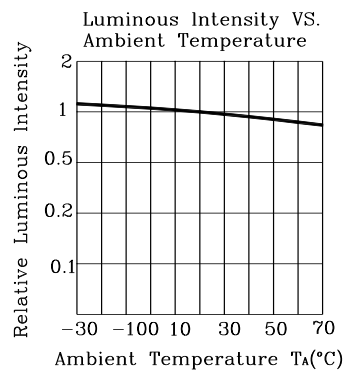
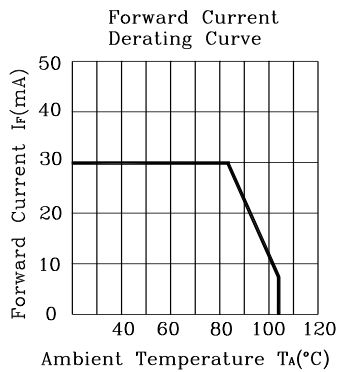
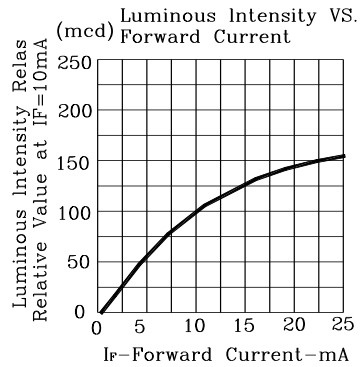
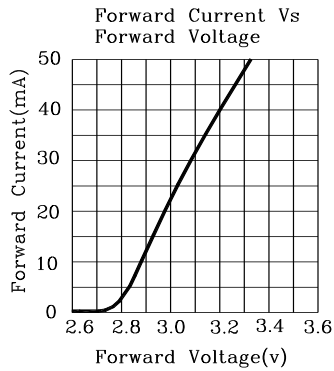

2214 SMD LED

ESS-2214TWD-J

REV:A /0

BIN NAMEING

BIN	Luminous Intensity(mcd)
1	60-80
2	80-100
3	100-130
4	130-170

BIN	Forward Voltage(V)
A	2.6-2.8
B	2.8-3.0
C	3.0-3.2

2214 SMD LED

ESS-2214TWD-J

REV:A /0

Color Chromaticity Groups

BIN J	
0.3253	0.3340
0.3243	0.3450
0.3331	0.3580
0.3341	0.3470

2214 SMD LED

ESS-2214TWD-J

REV:A /0

Package Tape Specifications: (3000 pcs/Reel)

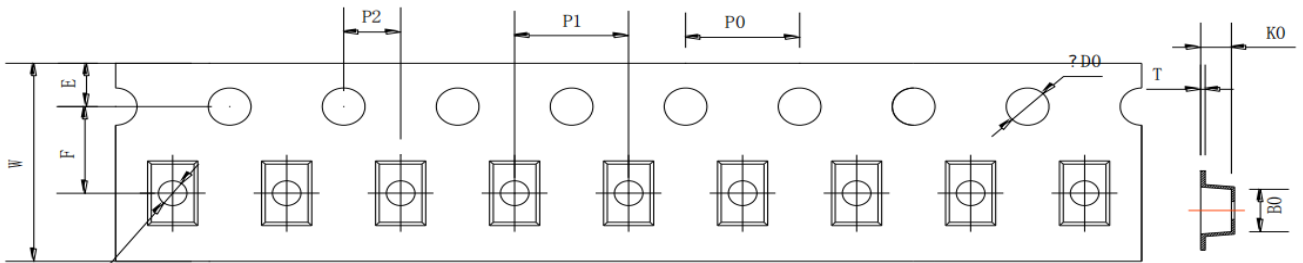
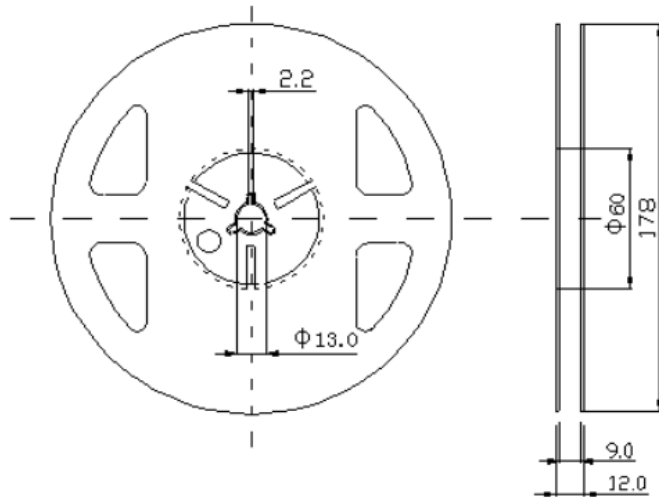

D1

symbol	A0	B0	K0	P0	P1	P2
Spec	1.50 ±0.05	2.35 ±0.05	1.48 ±0.10	4.00 ±0.10	4.00 ±0.10	2.00 ±0.05
symbol	W	T	E	F	D0	D1
Spec	8.00 ±0.10	0.22 ±0.05	1.75 ±0.10	3.50 ±0.10	1.50 ^{+0.10} ₀	1.00 ±0.05

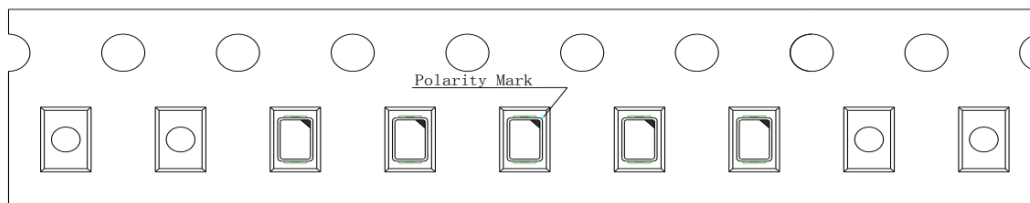
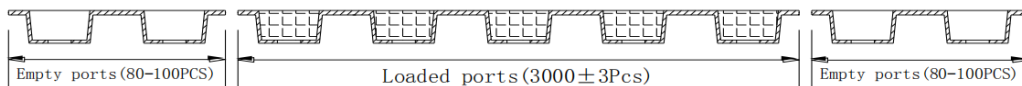
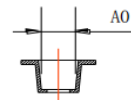

2214 SMD LED

ESS-2214TWD-J

REV:A /0

※ Precautions for use :

- 1) Customer must apply the current limiting resistor in the circuit so as to drive the LEDs within the rated current. Otherwise slight voltage shift maybe will cause big current change and burn out will happen.
- 2) Also, caution should be taken not to overload the LEDs with instantaneous high voltage at the turning ON and OFF of the circuit.
- 3) Storage:
 - a) 3.1 Don't open the moisture proof bag before ready to use the LEDs.
 - b) 3.2 The LEDs should be kept at 30°C or less and 60%RH or less before opening the package. The max. storage period before opening the package is 1 year.
 - c) 3.3 After opening the package, the LEDs should be kept at 30°C/35%RH or less, and it should be used within 7 days.
 - d) 3.4 If the LEDs be kept over the conditions of 3.4, baking is required before mounting.
Baking condition as below: $60 \pm 5^\circ\text{C}$ for 12 hrs.
- 4) Soldering condition:

4.1 Lead Solder:

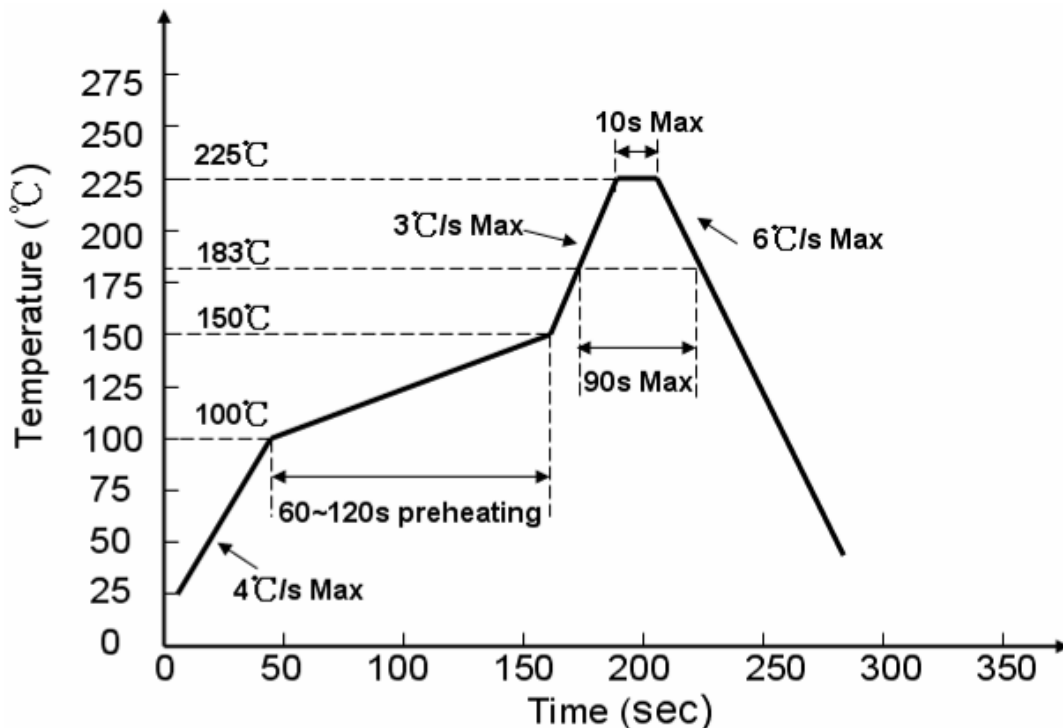

	2214 SMD LED	
	ESS-2214TWD-J	REV:A /0

4.2 Lead Free Solder:

Note:

- a) 1.Reflow soldering should not be done more than two times.
- b) 2. Don't put stress on the LEDs when soldering.
- c) 3.Don't warp the circuit board before it have been returned to normal ambient conditions after soldering

Looking for pricing, stock, or lifecycle information?

Click below to explore more details on WIN SOURCE:

- ⊖ [View ESS-2214TWD-J on WIN SOURCE](#)
- ⊖ [Shanghai Everstar Electronics Co., Ltd. Information](#)

Optimize Your Supply Chain with WIN SOURCE Solutions

- ✓ Global Sourcing Solution
- ✓ Obsolete Management
- ✓ Cost Control Management
- ✓ Shortage Management
- ✓ Alternative Solution
- ✓ Excess Inventory Management