



**THE DATASHEET OF
ESS-0805R7C-A-RB**





Jiangsu Everstar Electronics Co., Ltd.

Address:No.6 Xiangshan Rd, Tianmuhu Industry Park, Liyang City, Jiangsu Province, China

TEL: +86-519-87557772

FAX: +86-519-87557773

Http: www.everstarelect.com

DATA SHEET

ESL NO.. : ESS-0805R7C-A-RB

CUS NO. :

REV : A / 0

Producer: 苏书艺

Auditor _____

Approver: 储志华

CUSTOMER'S APPROVAL : _____

DCC : _____



2.0 × 1.25 × 1.1mm SMD LED

ESS-0805R7C-A-RB

REV:A / 0

※ **Features:**

1. 2.0×1.25×1.1mm SMD LED
2. Top view LED
3. Compatible with infrared and vapor phase reflow solder process.
4. Wide viewing angle
5. Pb-free
6. RoHS compliant

※ **Applications:**

1. General lighting
2. Decorative and Entertainment lighting
3. Status indicators
4. Automotive Telecommunication & Switch lights

※ **Color**

* Light Color : Dark-Red

* Lens Color : Water clear

※ Package Outline Dimension:

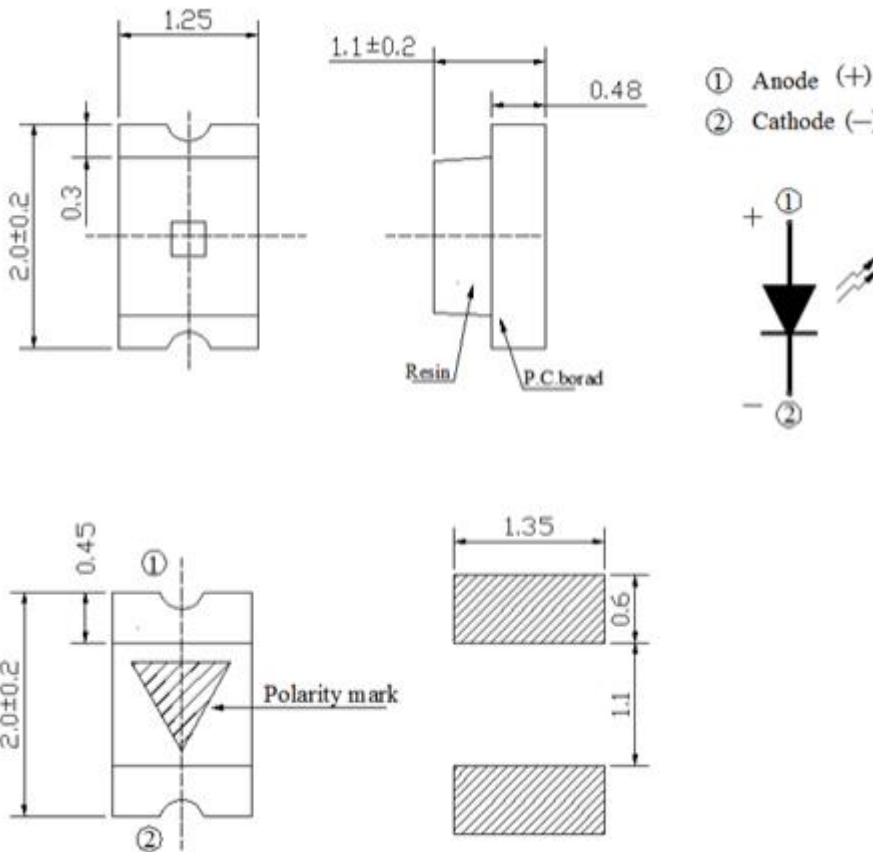

NOTES:

1. All dimensions are in millimeters (inches).
2. Tolerance is ±0.10mm unless otherwise specified.
3. Specifications are subject to change without notice.



2.0 × 1.25 × 1.1mm SMD LED

ESS-0805R7C-A-RB

REV:A / 0

※ Absolute Maximum Ratings(Ta=25°C)

Parameter	Symbol	Rating	Unit
Power Dissipation	Pd	75	mW
Pulse Forward Current *	I _{FP}	100	mA
Forward current	I _F	20	mA
Soldering Temperature	T _{sol}	260 (for 10 seconds)	°C
Operating Temperature	T _{opr}	-40°C~85°C	-
Storage Temperature	T _{stg}	-40°C~90°C	-
Reverse Voltage	V _R	5	V

Note:

The products are sensitive to static electricity and must be carefully taken when handling products.

※ Electrical-optical characteristics(Ta=25°C)

Parameter	Symbol	Min.	Typ.	Max.	Unit	Condition
Forward Voltage	V _f	1.7		2.2	V	I _F =20mA
Luminous Intensity	I _v	202.5		396	mcd	
Viewing Angle	2θ _{1/2}	-	140		deg	
Reverse Current	I _R		-	10	μA	V _R =5V
Wavelength	λ	649.5	/	661.5	nm	I _F =20mA
Dominant Wavelength	λ _D		657		nm	I _F =20mA

Note: 1. Tolerance of luminous intensity is ±10%

2. Tolerance of forward voltage is ±0.05V

2. Tolerance of Dominant Wavelength is ±0.1nm

※ Typical Electro-Optical Characteristics Curves

Fig.1 Forward Current vs Ambient Temperature

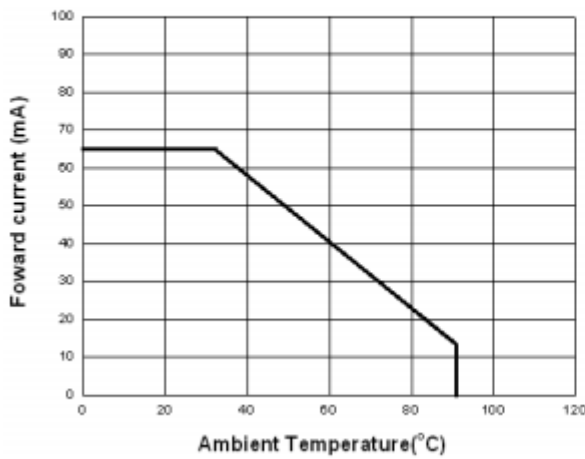

Fig.2 Spectral Sensitivity

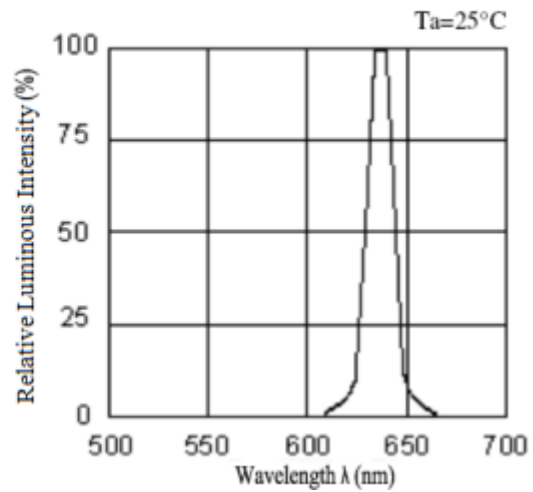

Fig.5 Luminous Intensity vs. Ambient Temperature

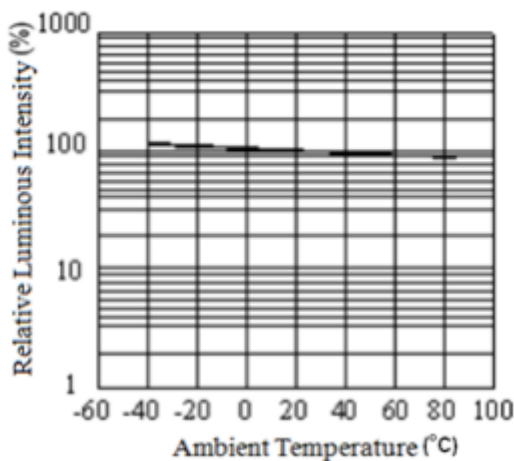
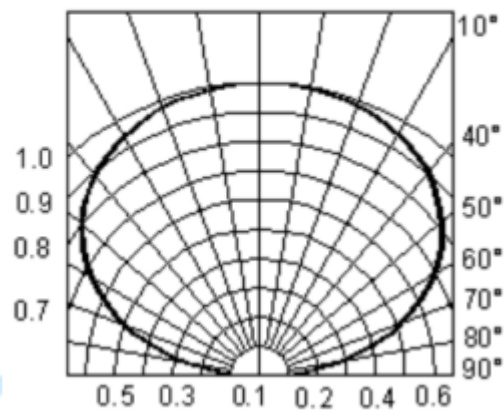
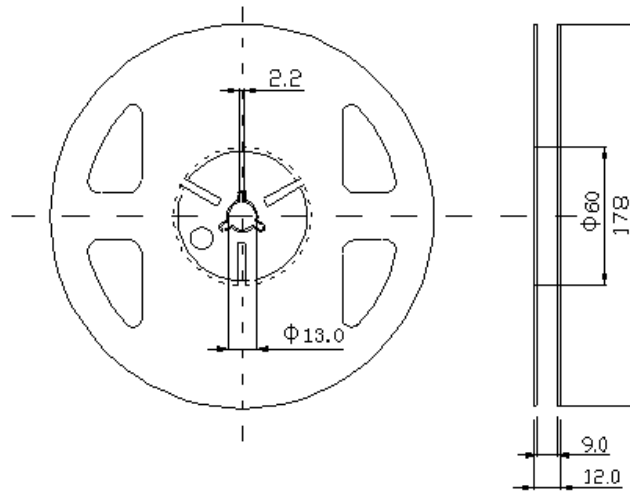

Fig.6 Radiation Diagram



※ Package Tape Specifications: (3000 pcs/Reel)



Note:
Tolerances unless mentioned $\pm 0.1\text{mm}$, Unit = mm.

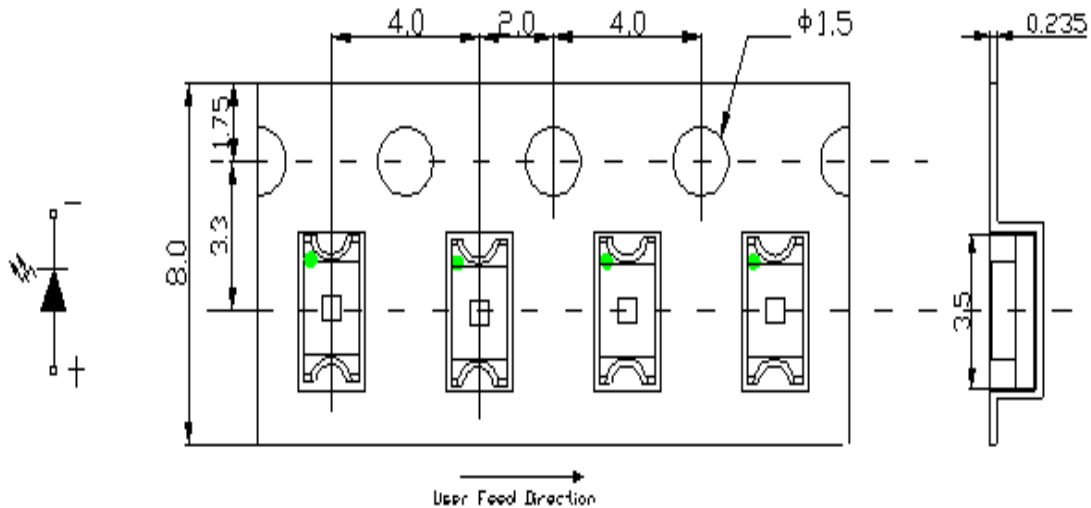

Note:
1. Tolerance unless mentioned is $\pm 0.1\text{mm}$, Unit = mm.
2. Minimum packing amount is 1000/2000 pcs per reel.



2.0 × 1.25 × 1.1mm SMD LED

ESS-0805R7C-A-RB

REV:A / 0

※ Precautions for use :

1. Customer must apply the current limiting resistor in the circuit so as to drive the LEDs within the rated current. Otherwise slight voltage shift maybe will cause big current change and burn out will happen.
2. Also, caution should be taken not to overload the LEDs with instantaneous high voltage at the turning ON and OFF of the circuit.
3. Storage:
 - 3.1 Don't open the moisture proof bag before ready to use the LEDs.
 - 3.2 The LEDs should be kept at 30°C or less and 60%RH or less before opening the package. The max. storage period before opening the package is 1 year.
 - 3.3 After opening the package, the LEDs should be kept at 30°C/35%RH or less, and it should be used within 7 days.
 - 3.4 If the LEDs be kept over the conditions of 3.4, baking is required before mounting. Baking condition as below: 60±5°C for 12 hrs.
4. Soldering condition:
 - 4.1 Manual of soldering:

The temp. of the iron should be lower than 260°C and soldering within 3sec per solder-pad is to be observed.
 - 4.2 Pb-free solder temp. -time profile
 - 4.3 DIP soldering (Wave Soldering) temp. -time profile:

Note:

- a) Reflow soldering should not be done more than two times.
- b) Don't put stress on the LEDs when soldering.
- c) Don't warp the circuit board before it have been returned to normal ambient conditions after soldering.

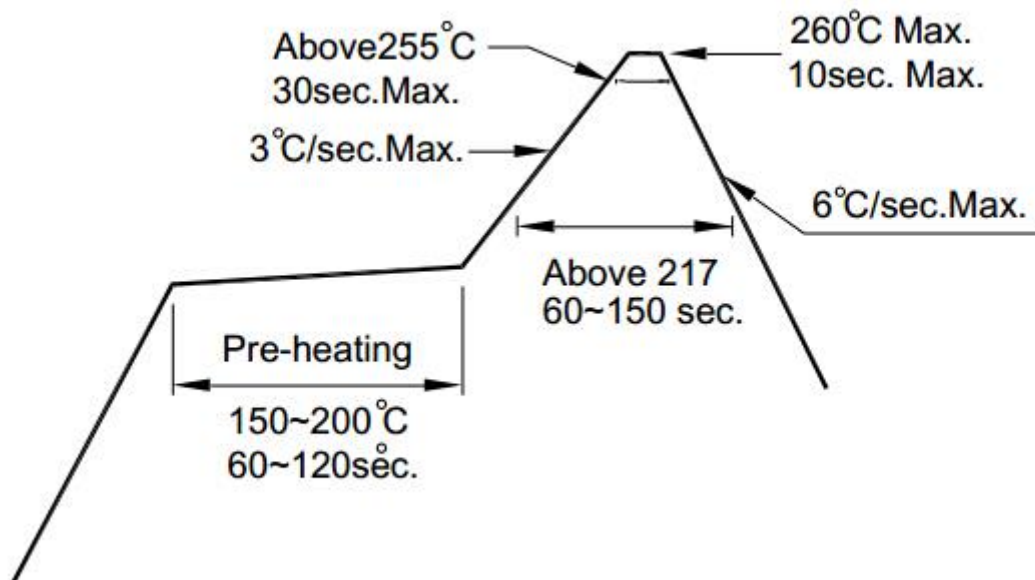

Looking for pricing, stock, or lifecycle information?

Click below to explore more details on WIN SOURCE:

- [View ESS-0805R7C-A-RB on WIN SOURCE](#)
- [Shanghai Everstar Electronics Co., Ltd. Information](#)

Optimize Your Supply Chain with WIN SOURCE Solutions

- ✓ Global Sourcing Solution
- ✓ Obsolete Management
- ✓ Cost Control Management
- ✓ Shortage Management
- ✓ Alternative Solution
- ✓ Excess Inventory Management