



**THE DATASHEET OF
ESS-JC150YGC-QT**



Jiangsu Everstar Electronics Co., Ltd.

Address:No.6 Xiangshan Rd, Tianmuhu Industry Park, Liyang City, Jiangsu Province, China

TEL: +86-519-87557772

FAX: +86-519-87557773

Http: www.everstarelect.com

DATA SHEET

ESL NO.. : ESS-JC150YGC-QT

CUS NO. :

REV : A / 0

Producer: *Eden*

Auditor _____

Approver: *Jack*

CUSTOMER'S APPROVAL : _____

DCC : _____

1206 SMD LED

ESS-JC150YGC-QT

REV:A / 0

※ **Features:**

- 1.3.2X1.6mm Chip SMD
- 2.Low power consumption
- 3.Pb-free
4. RoHS compliant
5. Package: 2000Pcs/Reel

※ **Color**

- * Light Color : Yellow Green
- * Lens Color : Water Clear
- * Dice Material :AlGaInP

1206 SMD LED

ESS-JC150YGC-QT

REV:A / 0

※ Package Outline Dimension:

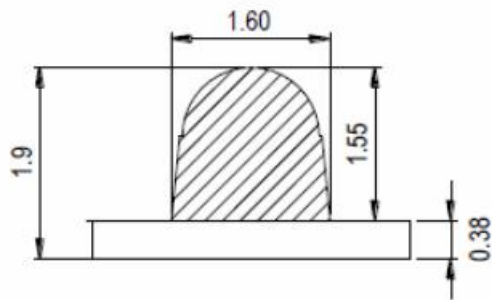
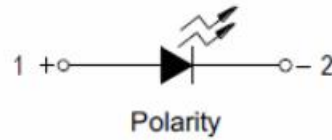
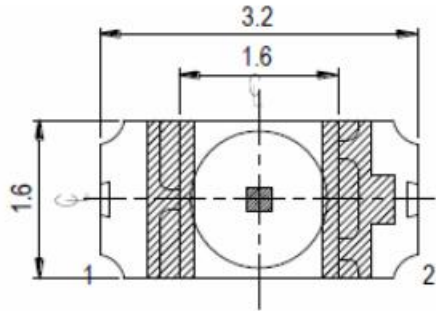

Recommended Solder Pad

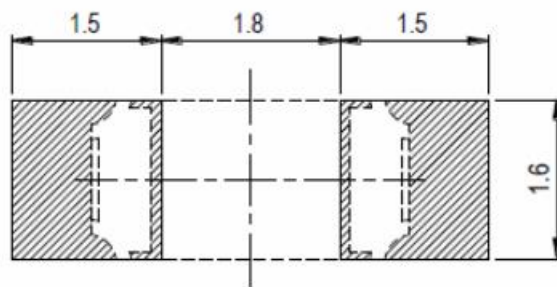
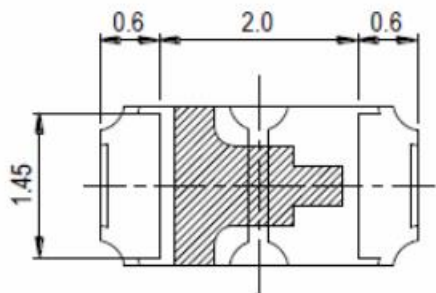

NOTES:

1. All dimensions are in millimeters (inches).
2. Tolerance is $\pm 0.10\text{mm}$ unless otherwise specified.
3. Specifications are subject to change without notice.

1206 SMD LED

ESS-JC150YGC-QT

REV:A / 0

※ Absolute Maximum Ratings(Ta=25°C)

Parameter	Symbol	Rating	Unit
Power Dissipation	Pd	55	mW
Pulse Forward Current *	I _{FP}	100	mA
Forward current	I _F	20	mA
Soldering Temperature	T _{sol}	260 (for 10 seconds)	°C
Operating Temperature	T _{opr}	-40°C~85°C	-
Storage Temperature	T _{stg}	-40°C~85°C	-
Reverse Voltage	V _R	5	V

Note:

The products are sensitive to static electricity and must be carefully taken when handling products.

※ Electrical-optical characteristics(Ta=25°C)

Parameter	Symbol	Min.	Typ.	Max.	Unit	Condition
Forward Voltage	V _f	1.8		2.2	V	I _F =20mA
Luminous Intensity	I _v	280		900	mcd	
Viewing Angle	2θ _{1/2}	-	30		deg	
Reverse Current	I _R		-	10	μA	V _R =5V
Dominant Wavelength	λ _d		570		nm	I _F =20mA

Note: 1. Tolerance of luminous intensity is ±10%

2. Tolerance of forward voltage is ±0.05V

2. Tolerance of Dominant Wavelength is ±0.1nm

1206 SMD LED

ESS-JC150YGC-QT

REV:A /0

BIN	Luminous Intensity(mcd)
SU2	280-360
SU3	360-450
SU4	450-570
SU5	570-720
SU6	720-900

1206 SMD LED

ESS-JC150YGC-QT

REV:A /0

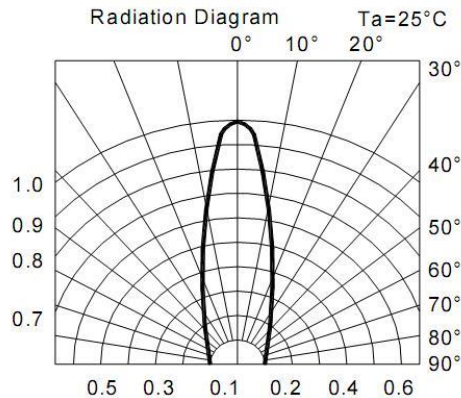
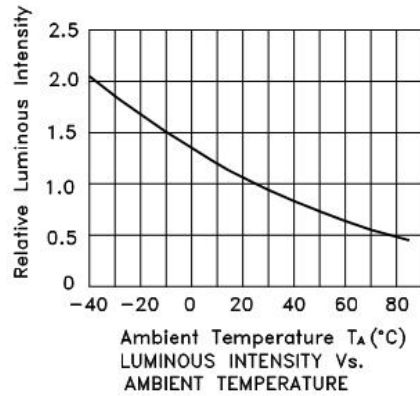
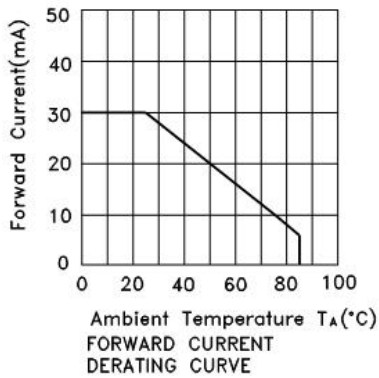
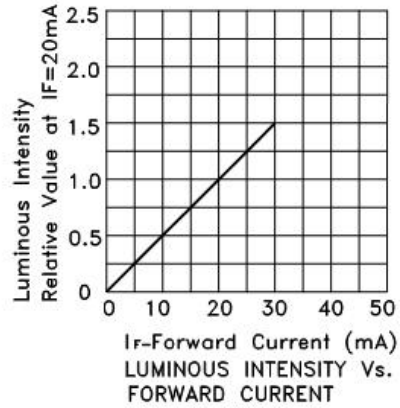
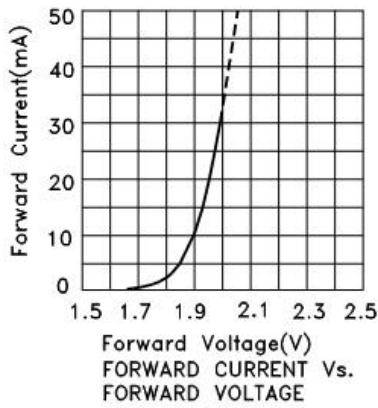
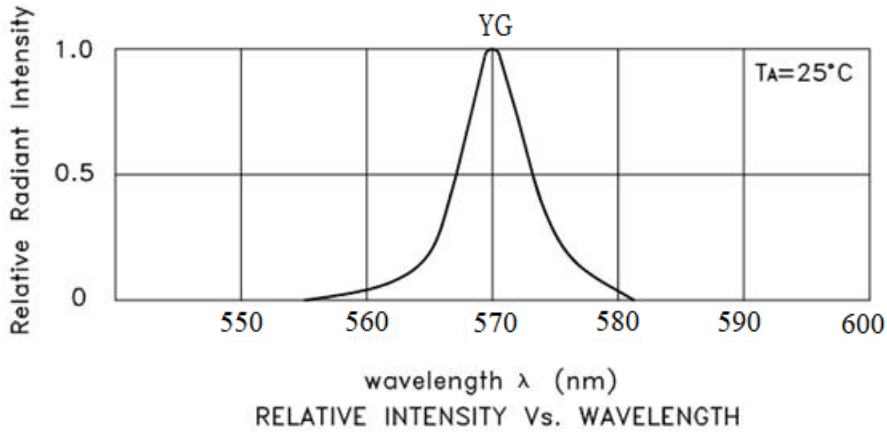

1206 SMD LED

ESS-JC150YGC-QT

REV:A / 0

※ Package Tape Specifications: (2000 pcs/Reel)

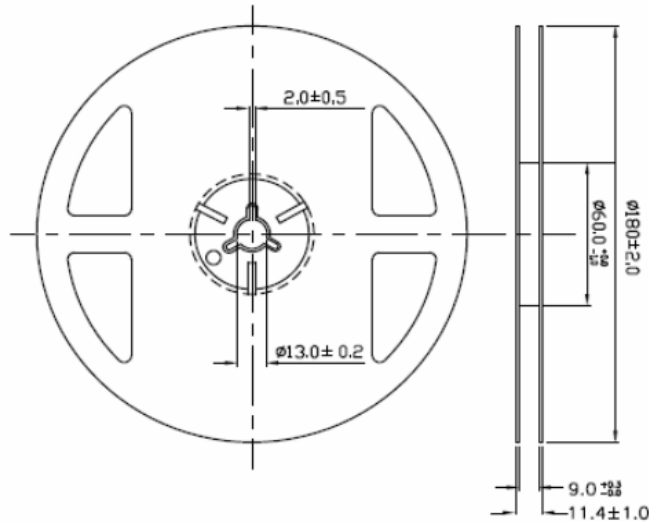

Note:
Tolerances unless mentioned $\pm 0.1\text{mm}$, Unit = mm.

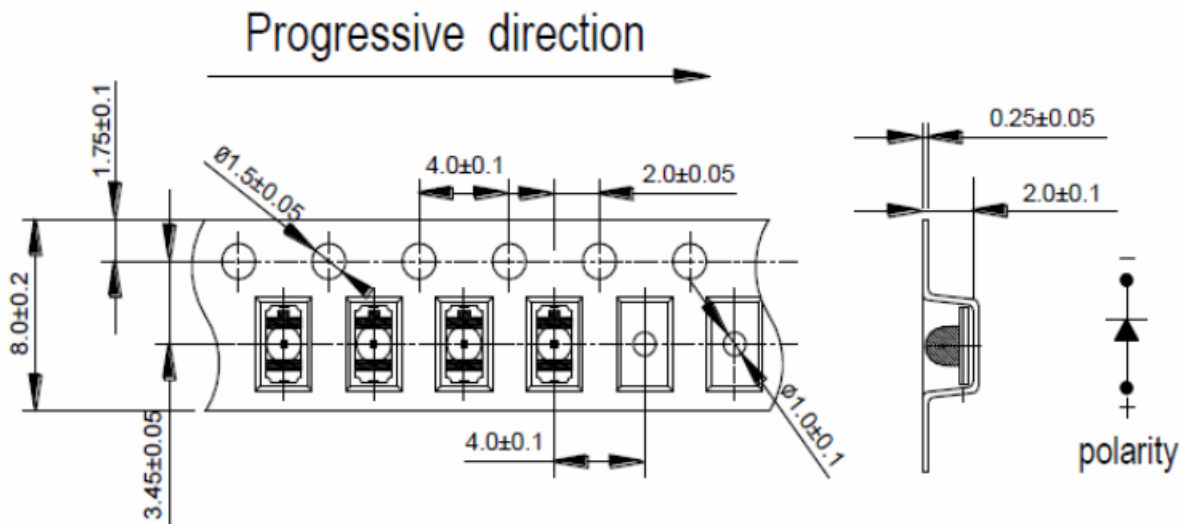

Note:
1. Tolerance unless mentioned is $\pm 0.1\text{mm}$, Unit = mm.

1206 SMD LED

ESS-JC150YGC-QT

REV:A / 0

※ Precautions for use :

1. Customer must apply the current limiting resistor in the circuit so as to drive the LEDs within the rated current. Otherwise slight voltage shift maybe will cause big current change and burn out will happen.
2. Also, caution should be taken not to overload the LEDs with instantaneous high voltage at the turning ON and OFF of the circuit.
3. Storage:

3.1 Don't open the moisture proof bag before ready to use the LEDs.

3.2 The LEDs should be kept at 30°C or less and 60%RH or less before opening the package.

The max. storage period before opening the package is 1 year.

3.3 After opening the package, the LEDs should be kept at 30°C/35%RH or less, and it should

be used within 7 days.

3.4 If the LEDs be kept over the conditions of 3.4, baking is required before mounting.

Baking

condition as below: 60±5°C for 12 hrs.

4. Soldering condition:

4.1 Manual of soldering:

The temp. of the iron should be lower than 260°C and soldering within 3sec per solder-pad is to be observed.

4.2 Pb-free solder temp. -time profile

4.3 DIP soldering (Wave Soldering) temp. -time profile:

Note:

a) Reflow soldering should not be done more than two times.

b) Don't put stress on the LEDs when soldering.

c) Don't warp the circuit board before it have been returned to normal ambient conditions after soldering.

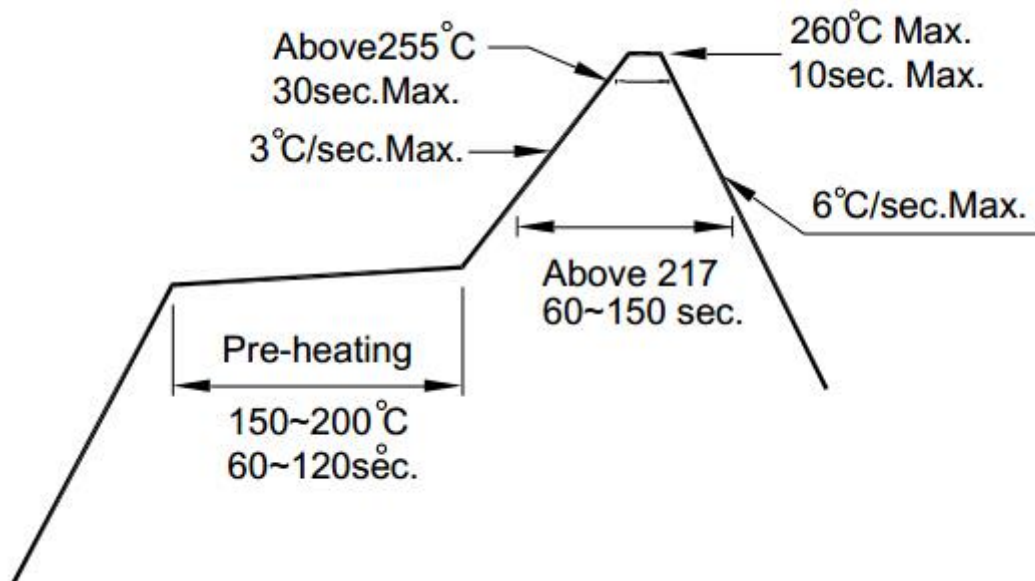

Looking for pricing, stock, or lifecycle information?

Click below to explore more details on WIN SOURCE:

- [View ESS-JC150YGC-QT on WIN SOURCE](#)
- [Shanghai Everstar Electronics Co., Ltd. Information](#)

Optimize Your Supply Chain with WIN SOURCE Solutions

- ✓ Global Sourcing Solution
- ✓ Obsolete Management
- ✓ Cost Control Management
- ✓ Shortage Management
- ✓ Alternative Solution
- ✓ Excess Inventory Management