



**THE DATASHEET OF**  
**3-794637-8**



**Micro MATE-N-LOK<sup>®</sup> Connectors**
**NOTE**

All numerical values are in metric units [with U.S. customary units in brackets]. Dimensions are in millimeters. Unless otherwise specified, dimensions have a tolerance of  $\pm 0.13$  and angles have a tolerance of  $\pm 2^\circ$ . Figures and illustrations are for identification only and are not drawn to scale.

**1. INTRODUCTION**

This specification covers the requirements for application of Micro MATE-N-LOK connectors for printed circuit (pc) board, panel mount, and free-hanging applications. Connectors are available in dual row with 2 through 24 contact positions, and single row with 2 through 12 positions on 3.00 mm centerline spacing. End cavities are marked with a number to provide circuit identification. The pin header is available, for wire-to-board applications, in vertical or right-angle configurations for through hole mount application or surface mount technology (SMT). The plug housings are available for panel mount or free-hanging wire-to-wire applications. The receptacle locking latch ensures positive mating of the connectors.

The pin header contains pre-installed solder type contacts with precision formed solder tines. The pin header is available with integral boardlocks (mechanical or plastic) or surface mount boardlocks (contacts with a board retention feature). These boardlocks provide stability for connector placement on the pc board. The connectors are placed on the pc board by hand application tooling or electrically-powered machines. The receptacle housing accepts only Micro MATE-N-LOK receptacle contacts sizes for 30-26 or 24-20 AWG wire. To ensure proper placement, the contact orientation barrel aligns with an orientation feature on the receptacle contact cavity. The contact contains a locking lance designed to engage the housing contact retention shoulder and prevent backing out during mating of the connector. The contacts are available in loose-piece for terminating with manual hand-held tools, and in strip form for terminating with semi-automatic or automatic electrically- powered machines.

The plug housing accepts only Micro MATE-N-LOK plug contacts sizes for 30-26 or 24-20 AWG wire. The plug contact can be inserted into the plug housing in one of two orientations 180° opposite of each other. The contacts have locking lances that will engage the housing retention shoulder in either contact orientation and prevent backing out during mating of the connector. When corresponding with TE Connectivity Personnel, use the terminology provided in this specification to facilitate your inquiries for information. Basic terms and features of this product are provided in Figure 1.

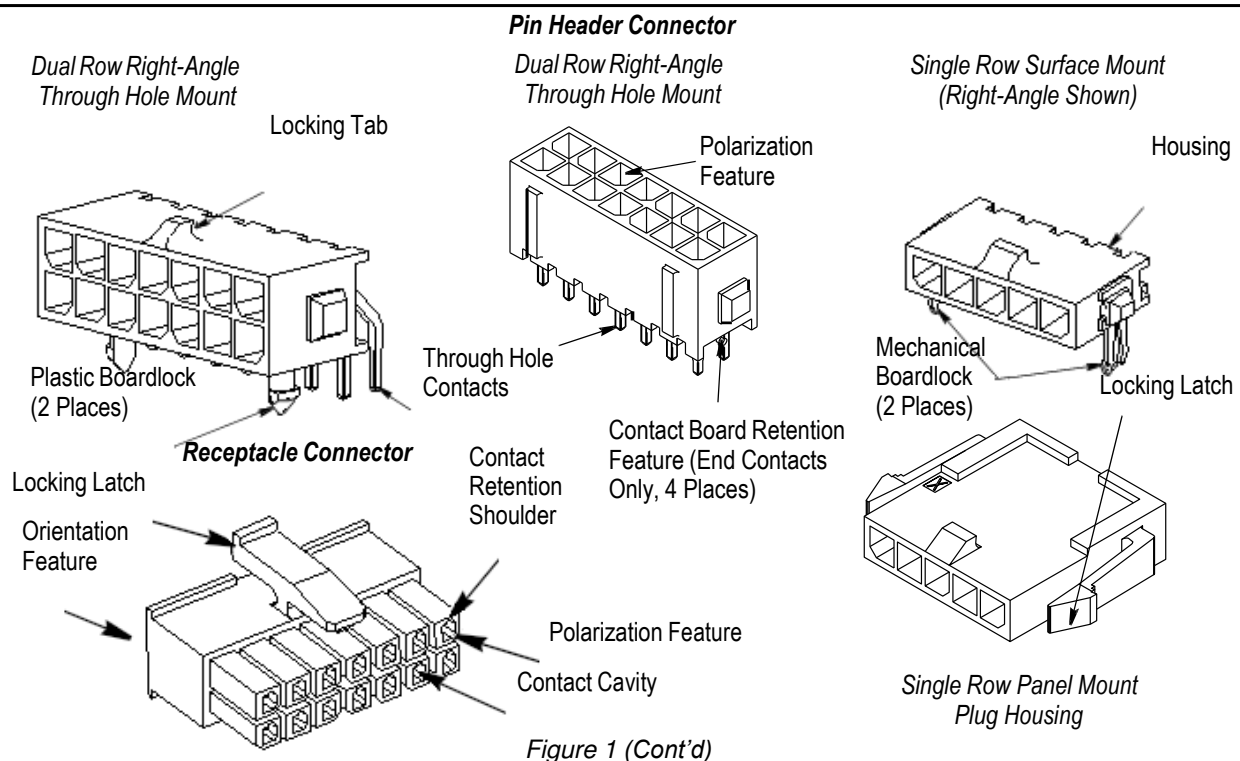

Figure 1 (Cont'd)

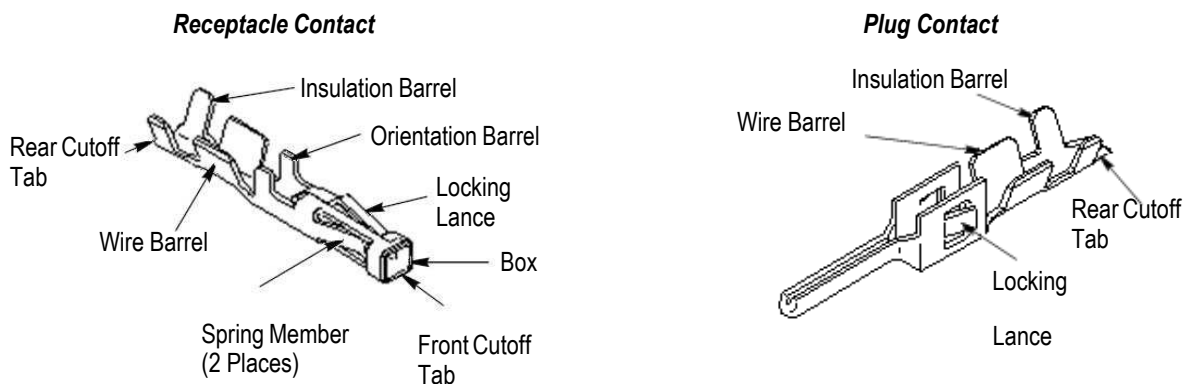

Figure 1 (End)

## 2. REFERENCE MATERIAL

### 2.1. Revision Summary

Revisions to this application specification include:

- Added new information to table in Figure 3
- Deleted and added new text to Paragraph 3.7.J
- Added new callout text to Figures 4 and 20

### 2.2. Customer Assistance

Reference Product Base Part Number 794618 and Product Code A309 are representative of Micro MATE-N-LOK Connectors. Use of these numbers will identify the product line and help you to obtain product and tooling information. Such information can be obtained through a local TE Representative, by visiting our website at [www.te.com](http://www.te.com), or by calling PRODUCT INFORMATION or the TOOLING ASSISTANCE CENTER at the numbers at the bottom of page 1.

### 2.3. Drawings

Customer Drawings for specific products are available from the service network. The information contained in Customer Drawings takes priority if there is a conflict with this specification or with any other technical documentation supplied by TE.

### 2.4. Manuals

Manual 402-40 is available upon request and can be used as a guide to soldering. This manual provides information on various flux types and characteristics with the commercial designation and flux removal procedures. A checklist is included in the manual as a guide for information on soldering problems.

### 2.5. Specifications

Product Specification 108-1836 provides product performance and test information.

### 2.6. Instructional Material

The following list includes available instruction sheets (408-series) that provide assembly procedures for product, operation, maintenance and repair of tooling, as well as setup and operation procedures of applicators; and customer manuals (409-series) that provide setup, operation, and maintenance procedures of machines.

| <u>Document Number</u> | <u>Document Title</u>   |
|------------------------|---|
| 408-3295               | Preparing Reel of Contacts for Applicator Tooling                     |
| 408-7424               | Checking Terminal Crimp Height  |
| 408-7497               | Recommended Procedures for "Crush" Crimp Technique                    |
| 408-8040               | Heavy Duty Miniature Quick-Change Applicators (Side-Feed Type)        |
| 408-8053               | Conversion Guide for Miniature Quick-Change Applicators               |
| 408-8059               | General Preventive Maintenance for Miniature Quick-Change Applicators |
| 408-8547               | CERTI-CRIMP* II Straight Action Hand Tools                            |

| <u>Document Number</u> | <u>Document Title</u>                                 |
|------------------------|---|
| 408-9816               | Handling of Reeled Products                           |
| 408-10020              | Extraction Reset Tool 843996-6                        |
| 409-5128               | AMP-O-LECTRIC* Model "K" Terminating Machine 565435-5 |
| 409-5842               | AMP-O-LECTRIC Model "G" Terminating Machine 354500-[] |
| 409-5866               | AMPOMATOR CLS IV Lead-Making Machine 217500-[]        |
| 409-10016              | Entry Level Terminator (ELT) Machine 1338600-[]       |
| 409-10027              | Stripping Modules 1490500 and 1490502                 |
| 409-10029              | Stripping Modules 1490501 and 1490503                 |

### 3. REQUIREMENTS

#### 3.1. Safety

Do not stack component packages so high that the shipping containers buckle or deform.

#### 3.2. Material

The receptacle housings are made of flame-retardant black thermoplastic, and the pin header housings are made of flame retardant high-temperature black thermoplastic to facilitate the soldering process. The mechanical boardlocks are made of phosphor bronze plated with tin and the plastic boardlocks are made of plastic. Micro MATE-N-LOK (receptacle) contacts are made of phosphor bronze and the pre-installed solder type (pin header) contacts are made of brass; both available in duplex 30m gold, 15m gold, or bright tin plating.

#### 3.3. Storage

##### A. Ultraviolet Light

Prolonged exposure to ultraviolet light may deteriorate the chemical composition used in the connector material.

##### B. Shelf Life

The contacts should remain in the shipping containers until ready for use to prevent deformation to the contacts. The contacts should be used on a first in, first out basis to avoid storage contamination that could adversely affect performance.

##### C. Reeled Contacts

When using reeled contacts, store coil wound reels horizontally and traverse wound reels vertically.

#### 3.4. Chemical Exposure

Do not store connectors or contacts near any chemical listed below as they may cause stress corrosion cracking in the connectors or contacts.

|          |            |          |            |          |                  |
|----------|------------|----------|------------|----------|------------------|
| Alkalies | Ammonia    | Citrates | Phosphates | Citrates | Sulfur Compounds |
| Amines   | Carbonates | Nitrites | Sulfur     | Nitrites | Tartrates        |

#### 3.5. Panel Mount Layout

Figure 2 provides the dimensions required for panel mounting the connectors. The recommended panel thickness is 1.57-2.3 mm.

#### 3.6. Wire Selection and Preparation

The contacts will accept stranded wire sizes 30 through 20 AWG with an insulation diameter range of 0.89 to 1.53 mm. Proper strip length is necessary to properly insert the wire into the contact. The strip length of the wire is shown in Figure 3.



*Reasonable care must be taken not to nick, scrape, or cut any strands during the stripping operation.*

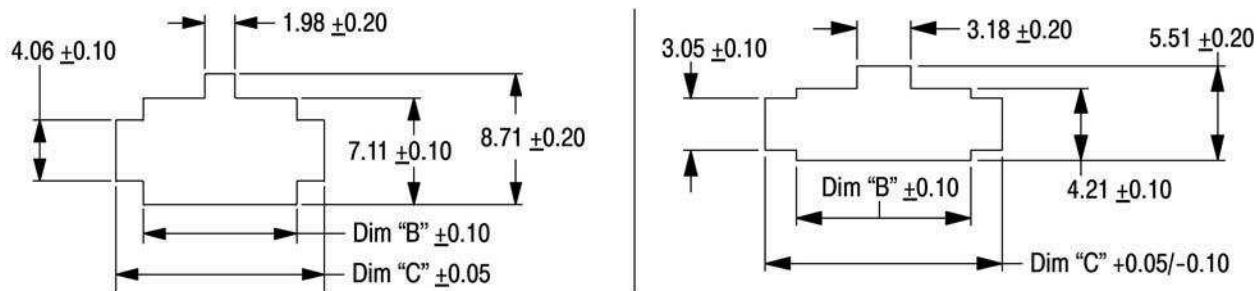

| PLUG HOUSING - DUAL ROW |               |               | PLUG HOUSING - SINGLE ROW |               |               |
|-------------------------|---------------|---------------|---------------------------|---------------|---------------|
| NO. OF POSITIONS        | DIMENSION "B" | DIMENSION "C" | NO. OF POSITIONS          | DIMENSION "B" | DIMENSION "C" |
| 2                       | 4.20          | 7.88          | 2                         | 7.20          | 10.88         |
| 4                       | 7.20          | 10.88         | 3                         | 10.20         | 13.88         |
| 6                       | 10.20         | 13.88         | 4                         | 13.20         | 16.88         |
| 8                       | 13.20         | 16.88         | 5                         | 16.20         | 19.88         |
| 10                      | 16.20         | 19.88         | 6                         | 19.20         | 22.88         |
| 12                      | 19.20         | 22.88         | 7                         | 22.20         | 25.88         |
| 14                      | 22.20         | 25.88         | 8                         | 25.20         | 28.88         |
| 16                      | 25.20         | 28.88         | 9                         | 28.20         | 31.88         |
| 18                      | 28.20         | 31.88         | 10                        | 31.20         | 34.88         |
| 20                      | 31.20         | 34.88         | 11                        | 34.20         | 37.88         |
| 22                      | 34.20         | 37.88         | 12                        | 37.20         | 40.88         |
| 24                      | 37.20         | 40.88         |                           | ---           |               |

Figure 2

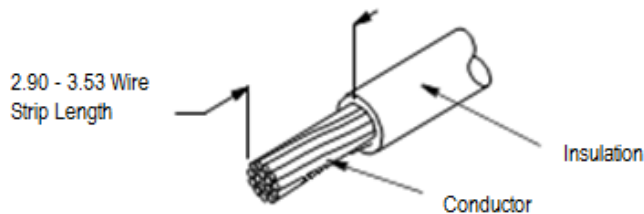

| CONTACT SIZE OR TERMINAL PN | WIRE SIZE (AWG) | CONTACT WIRE BARREL CRIMP    |           |            |           |              | CONTACT INSULATION BARREL CRIMP WIDTH |           |              |
|-----------------------------|-----------------|------------------------------|-----------|------------|-----------|--------------|---------------------------------------|-----------|--------------|
|                             |                 | HEIGHT ±0.05                 |           | WIDTH      |           | TYPE CRIMPER | APPLICATOR                            | HAND TOOL | TYPE CRIMPER |
|                             |                 | APPLICATOR                   | HAND TOOL | APPLICATOR | HAND TOOL |              |                                       |           |              |
| 30-26                       | 30              | 0.51                         | 0.58      | 1.07       | 1.07      | F            | 1.78                                  | 1.78      | F            |
|                             | 28              | 0.56 (Recpt.)<br>0.53 (Plug) |           |            |           |              |                                       |           |              |
|                             | 26              | 0.61 (Recpt.)<br>0.56 (Plug) |           |            |           |              |                                       |           |              |
| 24-20                       | 24              | 0.69                         | 0.74      | 1.40       | 1.40      | F            | 1.78                                  | 1.78      | F            |
|                             | 22              | 0.79                         | 0.74      |            |           |              |                                       |           |              |
|                             | 20              | 0.89                         | 0.89      |            |           |              |                                       |           |              |
| 24-20                       | 24              | 0.71                         | ---       | 1.27       | ---       | F            | 1.78                                  | ---       | F            |
|                             | 22              | 0.84                         | ---       |            |           |              |                                       |           |              |
|                             | 20              | 1.03                         | ---       |            |           |              |                                       |           |              |

| CONTACT SIZE OR TERMINAL PN | WIRE SIZE (AWG)      | CONTACT WIRE BARREL CRIMP |           |            |           |              | CONTACT INSULATION BARREL CRIMP WIDTH |           |              |
|-----------------------------|----------------------|---------------------------|-----------|------------|-----------|--------------|---------------------------------------|-----------|--------------|
|                             |                      | HEIGHT $\pm 0.05$         |           | WIDTH      |           | TYPE CRIMPER | APPLICATOR                            | HAND TOOL | TYPE CRIMPER |
|                             |                      | APPLICATOR                | HAND TOOL | APPLICATOR | HAND TOOL |              |                                       |           |              |
| 22-18                       | 22                   | 0.84                      | ---       | 1.58       | ---       | F            | 2.79                                  | ---       | O            |
|                             | 20                   | 0.94                      |           |            |           |              |                                       |           |              |
|                             | 18                   | 1.09                      |           |            |           |              |                                       |           |              |
| PN 2825493-1 (*)            | 0.5 mm <sup>2</sup>  | 0.83 +/- 0.03             | ---       | 1.40       | ---       | F            | 1.78                                  | ---       | F            |
| PN 794606-1 (*)             | 0.35 mm <sup>2</sup> | 0.79 +/- 0.03             | ---       | 1.40       | ---       | F            | 1.78                                  | ---       | F            |

(\*) Applicator used for qualification was the PN 2151022-1 (terminal/crimp validated according to Automotive requirements of Slow-Motion Bending Test).

Figure 3

### 3.7. Crimp Requirements



Wire insulation must NOT be cut or broken during the crimping operation. Reasonable care should be taken to provide undamaged wire terminations.

The contact must be crimped to the wire according to instructions packaged with applicable tooling.

#### A. Cutoff Tab and Burr

Cutoff tabs are the remaining portion of the carrier strip after the contact is cut from the strip. The following dimensional requirements will ensure proper application for these contacts.

1. The front cutoff tab must not extend beyond the contact box and the rear cutoff tab must not extend beyond the insulation barrel more than the limits shown in Figure 4.
2. The burr resulting from the cutoff tab shearing must not exceed the dimension shown in Figure 4.

#### B. Locking Lance

The height of the locking lances must be within the specified limits shown in Figure 4.

#### C. Spring Members

There must be no damage or distortion to the spring members of the receptacle contacts or the pin end of the plug contact. See Figure 4.

#### D. Orientation Barrel

There must be no damage or distortion to the orientation barrel. See Figure 4.

#### E. Wire Barrel Crimp

The crimp applied to the wire barrel portion of the contact is the most compressed area and is most critical in ensuring optimum electrical and mechanical performance of the crimped contact. The wire barrel must be crimped in the "F" crimp where the tips of the wire barrel turn inward and capture the wire strands. The wire barrel crimp height and width must be within the dimensions provided in Figure 4.

#### F. Effective Crimp Length

Effective crimp length is defined as that portion of the wire barrel, excluding bellmouths, fully formed by the crimping tool. For optimum crimp effectiveness, the crimp must be within the limits shown in Figure 4.

#### G. Wire Barrel Seam

The seam between the two sides of the wire barrel must be completely closed and there must be no evidence of loose wire strands or wire strands visible in the seam. Refer to Figure 4.

#### H. Bellmouths

The front and rear bellmouths caused by extrusion of the contact material during crimping must be within the limits shown in Figure 4.

### I. Wire Barrel Flash

Wire barrel flash is the formation that may appear on both sides of the wire barrel as the result of crimping. It must not exceed the dimension provided in Figure 4.

### J. Insulation Barrel Crimp

The insulation barrel crimp is crimped to form a support for the insulation. The insulation barrel must be crimped in the "F" crimp for contact sizes 30-26 and 24-20 where the tips of the insulation barrel turn inward and capture the wire insulation. The insulation barrel must be crimped in the "O" crimp for contact size 22-18 where the tips of the insulation barrel pass by each other and capture the wire insulation.

### K. Insulation Barrel Seam

The seam between the two sides of the insulation barrel must be completely closed and grasp the wire insulation. Refer to Figure 4.

### L. Conductor Location

The wire insulation and conductor must be visible within the transition area (between the contact insulation barrel and wire barrel). The insulation must not enter the wire barrel. The wire conductor ends be flush to or extend slightly beyond the wire barrel to the limit provided in Figure 4.

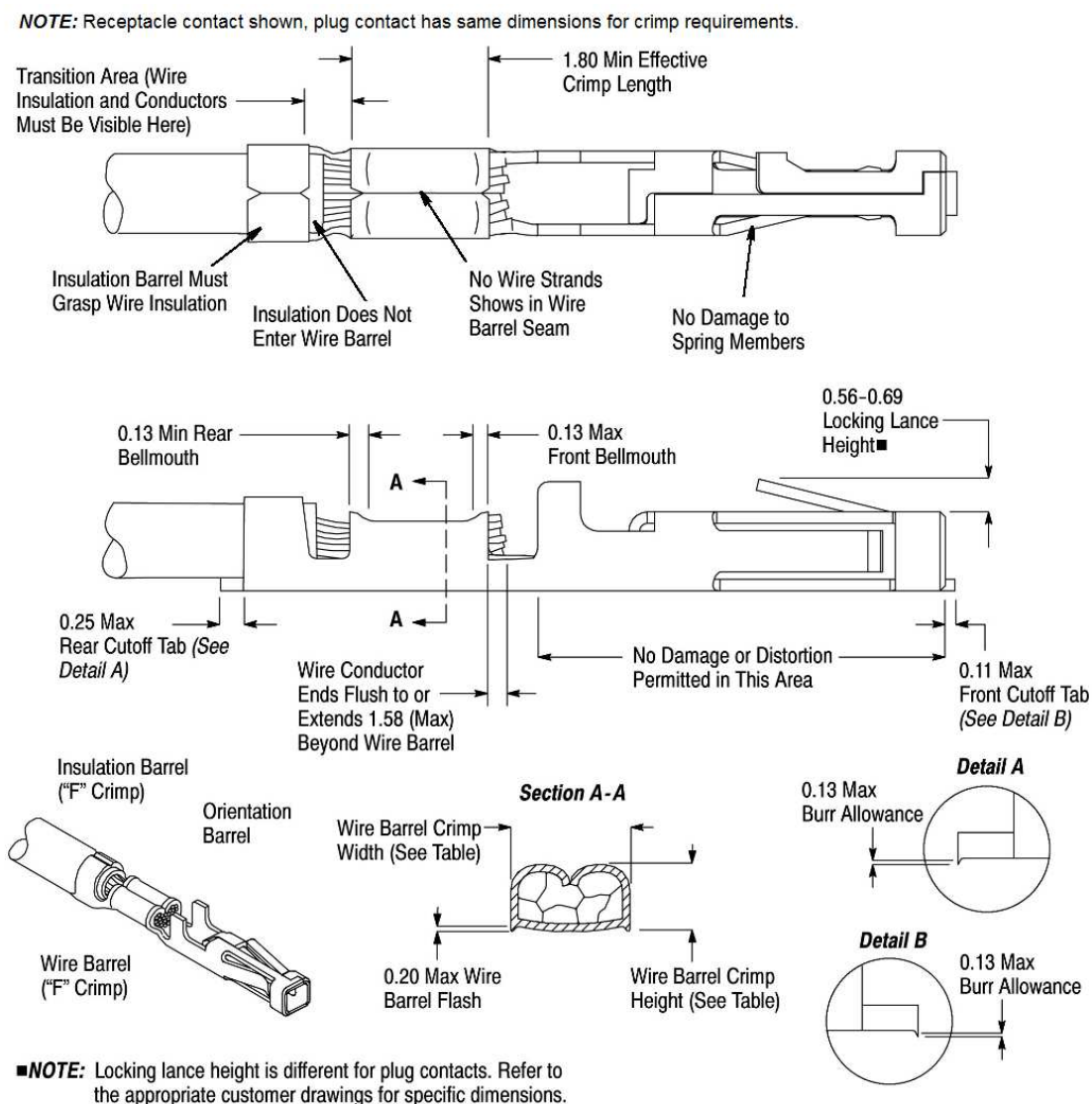

Figure 4

**NOTE**

The developed crimp configurations result from using the specific tooling described in Section 5, TOOLING.

**M. Straightness**

The force applied during crimping may cause some bending between the wire barrel and the mating portion of the contact. Such deformation is acceptable within the following limits.

## 1. Up and Down

The crimped portion, including cutoff tab and burr, must not be bent beyond the limits shown in Figure 5.

## 2. Side-to-Side

The crimped portion must not be bent from one side to the other beyond the limits shown in Figure 5.

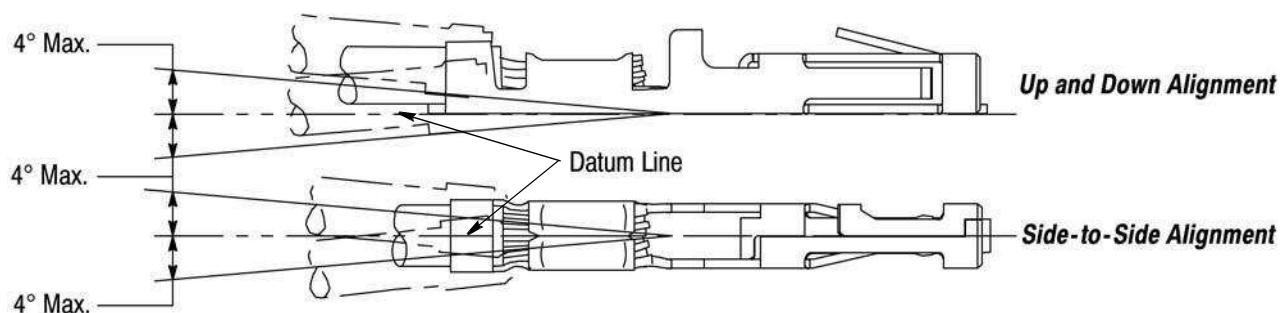

Figure 5

**N. Twist and Roll**

There should be no twist or roll of the wire barrel or mating portion of the crimped contact beyond the limits shown in Figure 6.

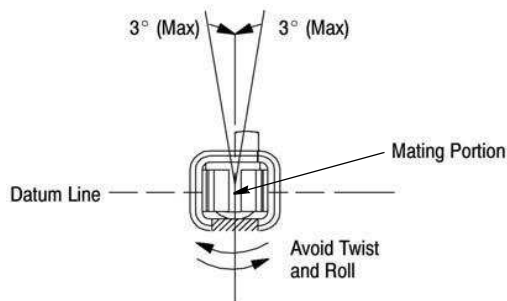

Figure 6

**3.8. Placement of Crimped Contacts****A. Receptacle Housing**

The contact orientation barrel must be aligned with the receptacle contact cavity orientation feature (located on the back of the receptacle). The contact must be inserted into the housing contact cavity and snapped into place. When fully inserted, the contact locking lance will engage the receptacle contact retention shoulder and prevent backing out during mating of the connectors. After inserting contact into housing, pull back lightly on the wire to ensure contact is fully seated. See Figure 7.

**NOTE**

An insertion tool is not required to insert contacts into receptacles.





Receptacle contacts are for use with receptacle housings only. Do not insert receptacle contacts into plug housings.

Back of Receptacle

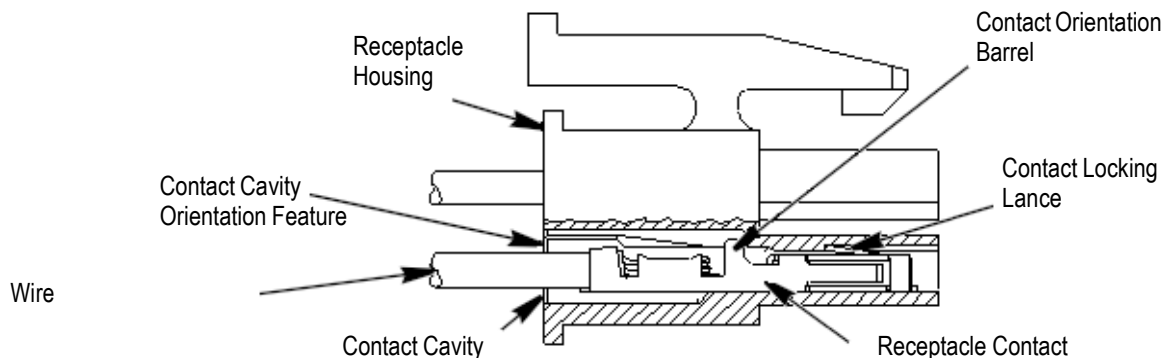

Figure 7

### B. Plug Housing

The plug contact can be aligned in one of two different ways, (180° opposite each other) during insertion into a plug housing. Either alignment is acceptable and will provide engagement of the lances with the housing locking shelves and prevent backing out during mating of connectors. After inserting contacts into the housing, pull back lightly on the wire to ensure the contact is fully seated. See Figure 8.



Plug contacts are for use with plug housings only. Do not insert plug contacts into receptacle housings.

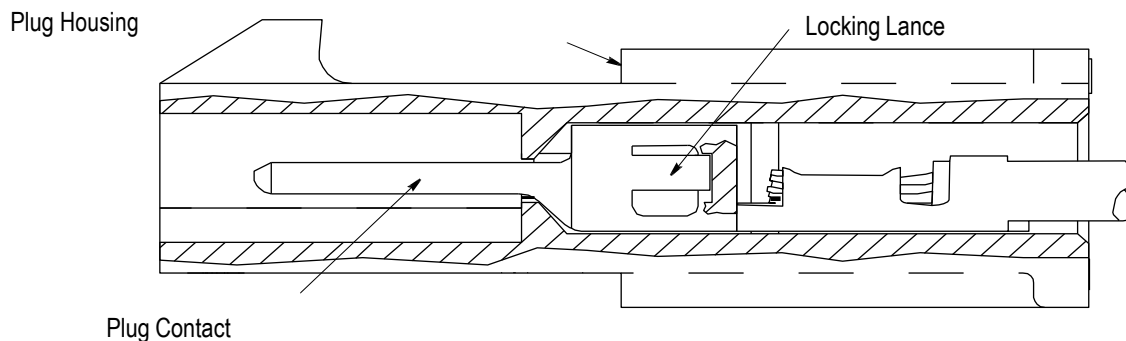

Figure 8

### 3.9. Connector Spacing

Care must be used to avoid interference between adjacent connectors and other components. The minimum allowable distance between pin headers to ensure proper mating is provided in Figure 9.

### 3.10. PC Board

#### A. Material and Thickness

The pc board material shall be glass epoxy (FR-4 or G-10). The pc board thickness shall be 1.57 mm.

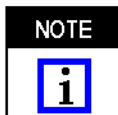

Contact the Product Information Center at the number listed at the bottom of page 1 for suitability of other board materials and thicknesses.

## B. Tolerance

Maximum allowable bow of the pc board shall be 0.03 mm over the length of the pin header.

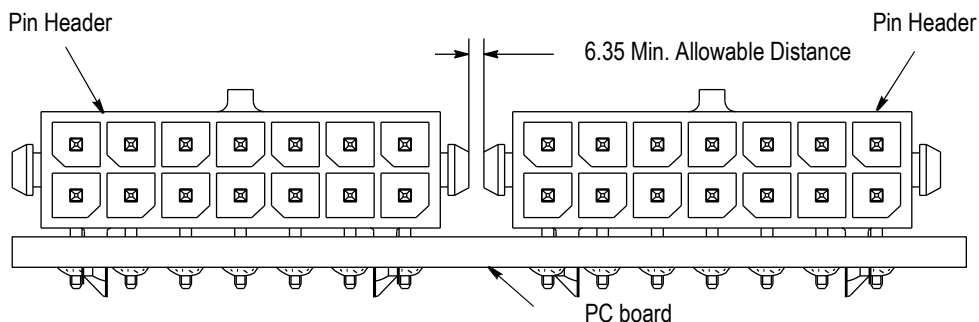

Remark: Allowable distance can be smaller (2 mm min.) for other versions where is not used holddown SMT version.

Figure 9

## C. Layout for Through Hole Mount Connectors

1. The pc board and lead wires must be solderable in accordance with Test Specification 109-11.
2. The pc board holes for the contact solder tines and boardlocks must be drilled and plated through to specific dimensions to prevent stubbing during placement of the connector on the pc board and to ensure optimum continuity for circuits after soldering. The drilled hole size, plating types, and plating thickness will depend on application requirements. The finished hole size must be as stated to provide unrestricted insertion and ensure adequate application of solder to the solder tines. See Figure 10.
3. The contact holes and boardlock holes in the pc board must be precisely located to ensure proper placement and optimum performance of the connector. Design the pc board using the dimensions provided in Figure 11.

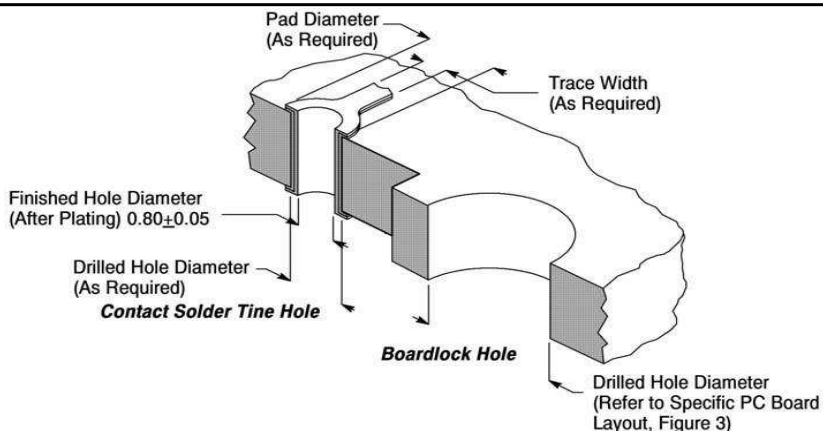

Figure 10

## D. Layout for Surface Mount Connectors

1. The pc board pads must be solderable in accordance with EIA-638 (Electronic Industries Alliance).
2. The connector boardlock holes on the pc board require precise drilling dimensions and the location of the circuit pads to these holes is critical to ensure proper placement and optimum performance of the connector. Recommended pc board pad pattern, dimensions, and tolerances are shown in the customer drawings of each header Micro MATE-N-LOK.

### NOTE



Four representative examples of recommended pc board patterns, dimensions, and tolerance; consult the customer drawings that contains pc board layouts or part numbers not listed in this document. Component side shown. See Paragraph 2.3.

### 3.11. Soldering Process

**NOTE**

After the connector is seated onto the pc board, the mechanical boardlocks must be soldered along with the contacts during the soldering process. Plastic boardlocks are not soldered.

Observe guidelines and procedures when soldering contacts. Solder, clean, and dry all contacts according to the following:

#### A. Recommended Solder Paste Characteristics

1. Alloy type must be 63 Sn/37 Pb or 60 Sn/40 Pb.
2. Flux must be RMA type.
3. Solids by weight must be 85% minimum.
4. Mesh designation -200 to +325 (74 to 44 square micron openings, respectively).
5. Minimum viscosity of screen print must be 510% cp (centipoise).
6. Minimum viscosity of stencil print must be 7.510% cp (centipoise).

#### B. Solder Paste Thickness

Solder paste thickness for the solder tines must be 0.22-0.25 mm.

#### C. Stencil

Stencil aperture is determined by the size of the circuit pad and thickness of the stencil. Generally, thinner stencils will need larger apertures to maintain a given volume of solder paste. Stencil thickness must range from 0.20 to 0.25 mm. Typically, a stencil thickness of 0.22 mm with apertures slightly smaller than the pad layout will provide satisfactory results. Solder deposition should be within each pad area.

**CAUTION**

All traces must be covered by solder mask in the solder deposit area. Exposed traces could cause bridging and create a short, or wick solder away, producing a weak solder joint.

**CAUTION**

If a hold-down aperture is used, the design must ensure that the connector housing will not sit on the solder deposit.

#### D. Solder Volume

Minimum solder volume (before curing) for each solder pad and boardlock pad is calculated by multiplying the pad length by the pad width by the stencil thickness. Recommended solder volume deposit (wet paste per solder pad) must be:

- 0.71 mm<sup>3</sup> per contact solder tine for vertical pin header connectors
- 0.81 mm<sup>3</sup> per contact solder tine for right angle pin header connectors
- 1.24 mm<sup>3</sup> per boardlock

**NOTE**

Solder volume may vary depending on solder paste composition.

#### E. Solder Mask

Solder mask is recommended between all pads. If a trace is run between adjacent pads on the solder side of the pc board, a solder mask must be applied over the trace to prevent bridging and wicking of solder away from the contact solder tines. Additionally, there should be solder mask covering any traces in the area of the boardlock (if applicable) solder deposit. Liquid photo imageable or dry film solder masks are recommended.

## F. Flux Selection

Contact solder tines must be fluxed prior to soldering with a mildly active, rosin base flux. Selection of the flux will depend on the type of pc board and other components mounted on the board. Additionally, the flux must be compatible with the wave solder line, manufacturing, health, and safety requirements. Call Product Information Center at the number at the bottom of page 1 for consideration of other types of flux. Flux that is compatible with these pin headers are provided in Figure 12.

| FLUX TYPE | ACTIVITY | RESIDUE      | COMMERCIAL DESIGNATION |       |
|-----------|----------|--------------|------------------------|-------|
|           |          |              | KESTER                 | ALPHA |
| RMA       | Mild     | Noncorrosive | 186                    | 611   |

Figure 12

## G. Connector Placement



If connectors are placed on the board manually, the connector should be handled only by the housing to avoid deformation, contamination, or damage to the contact solder tines and boardlocks.

### 1. Surface Mount Connectors

Optimally, the contact solder tines should be centered on the pc board circuit pads. However, slight misalignment is permissible as shown in Figure 13.

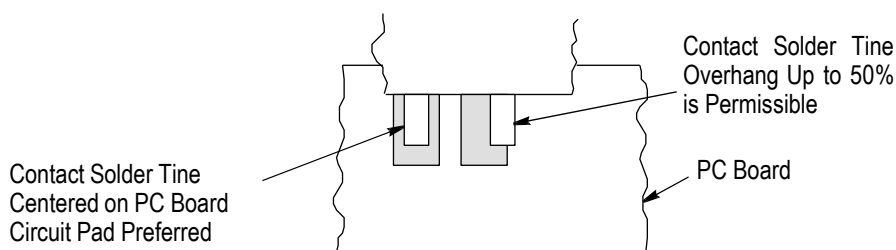

Figure 13

### 2. Through Hole Mount Connectors

When placing through hole mount connectors on the pc board, make sure that the contact solder tines are aligned and started into the matching holes before seating the connector onto the pc board.

## H. Technique

The connectors can be soldered using wave, non-focused infrared (IR) reflow soldering, or equivalent soldering technique. It is recommended using SN60 or SN62 solder for these connectors. The temperatures and exposure time must be as specified in Figure 14.

| SOLDERING PROCESS | TEMPERATURE (Max) | TIME (At Max Temperature) |
|-------------------|-------------------|---------------------------|
| Wave              | 260°C [500°F]     | 5 Seconds                 |
| IR                | 225°C [378°F]     | 90 Seconds                |

Figure 14

## I. Cleaning

After soldering, removal of fluxes, residues, and activators is necessary. Consult with the supplier of the solder and flux for recommended cleaning solvents. Cleaners must be free of dissolved flux and other contaminants. The following is a list of common cleaning solvents that will not affect connectors for the time and temperature specified. See Figure 15.

KESTER and ALPHA are trademarks of their respective owners.



Even when using “no clean” solder paste, it is imperative that the contact interface be kept clean of flux and residue, since it acts as an insulator. Flux may migrate under certain conditions with elevated temperatures and, therefore, cleaning is necessary.



Consideration must be given to toxicity and other safety requirements recommended by the solvent manufacturer. Refer to the manufacturer's Material Safety Data Sheet (MSDS) for characteristics and handling of cleaners. It is not recommended using Trichloroethylene and Methylene Chloride because of harmful occupational and environmental effects. Both are carcinogenic (cancer-causing).

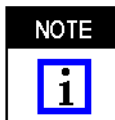

If you have a particular solvent that is not listed, contact the Product Information Center at the number at the bottom of page 1.

| CLEANER           |         | TIME<br>(Minutes) | TEMPERATURE<br>(Maximum) |
|-------------------|---------|-------------------|--------------------------|
| NAME              | TYPE    |                   |                          |
| ALPHA 2110        | Aqueous | 1                 | 132°C [270°F]            |
| BIOACT EC-7       | Solvent | 5                 | 100°C [212°F]            |
| Butyl CARBITOL    | Solvent | 1                 | Ambient Room             |
| Isopropyl Alcohol | Solvent | 5                 | 100°C [212°F]            |
| KESTER 5778       | Aqueous |                   |                          |
| KESTER 5779       | Aqueous |                   |                          |
| LONCOTERGE 520    | Aqueous |                   |                          |
| LONCOTERGE 530    | Aqueous |                   |                          |
| Terpene           | Solvent |                   |                          |

Figure 15

## J. Drying

When drying cleaned assemblies, make certain that temperature limitations are not exceeded: -40° to 105°C [-68° to 221°F]. Excessive temperatures may cause housing degradation or plating deterioration.

### 3.12. Checking Installed Connector

All solder joints should conform to the requirements specified in this document and those specified in the following: Workmanship Specification 101-21 for surface mount connectors  
Test Specification 109-11 for through hole mount connectors

Solder must be evenly distributed and not cracked. The connector standoffs must be seated on the pc board, and the housing not exceeding the dimension shown in Figure 16.

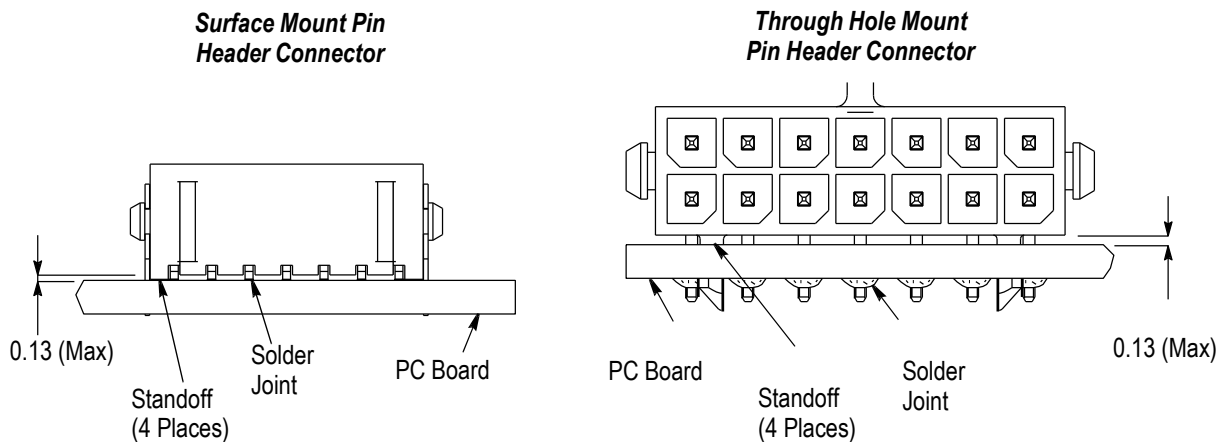

Figure 16

ALPHA, BIOACT, CARBITOL, KESTER, and LONCOTERGE are trademarks of their respective owners.

### 3.13. Polarization

The design of each contact cavity assures polarization for mating connectors.

### 3.14. Mating Connectors



Connectors should be handled only by the housing to avoid deformation, contamination, or damage to the contact solder tines.

The receptacle has an integral locking latch that should be fully seated and latched to the pin header locking tab after mating. The locking latch and locking tab ensures positive mating of connectors. The distance between mating connectors must be considered when determining location of connectors to ensure full mating. The mated dimension of the receptacle housing to the pin header housing is provided in Figure 17.

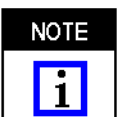

Receptacles will mate only with the appropriate pin headers or plug housings; the receptacle and pin header or plug housing must have identical number of circuit positions and rows.

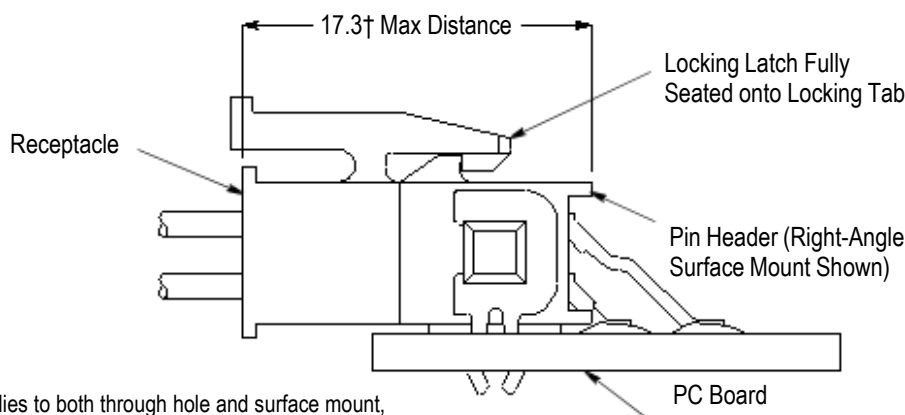

†Dimension applies to both through hole and surface mount, and right-angle and vertical pin headers when mated.

Figure 17

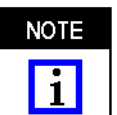

For connectors with plastic holddowns is recommendable to assemble them aligned with the PC board, according to showed below, otherwise, plastic holddowns can break when forced more of one side than other

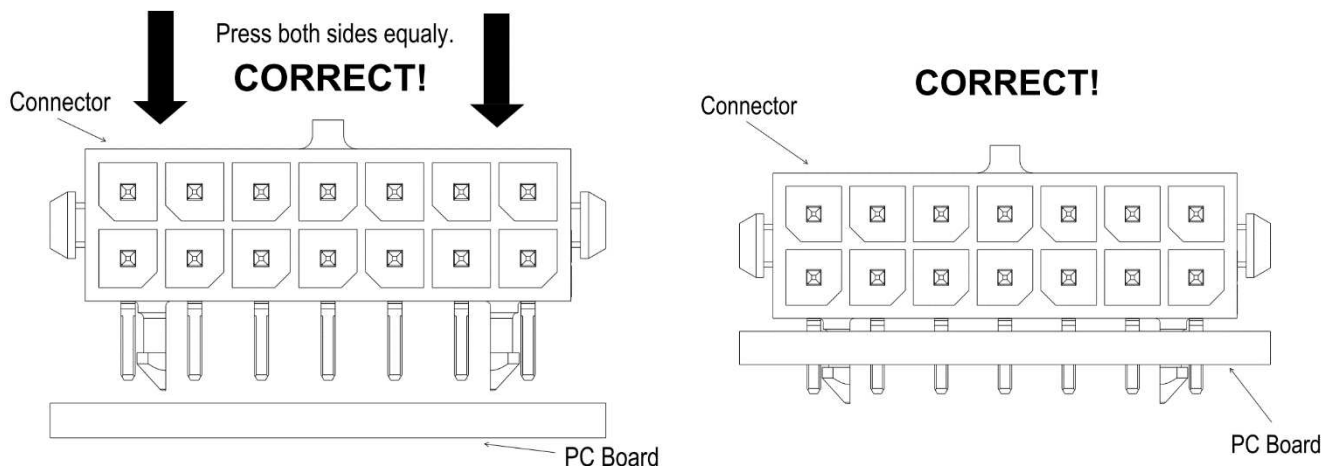

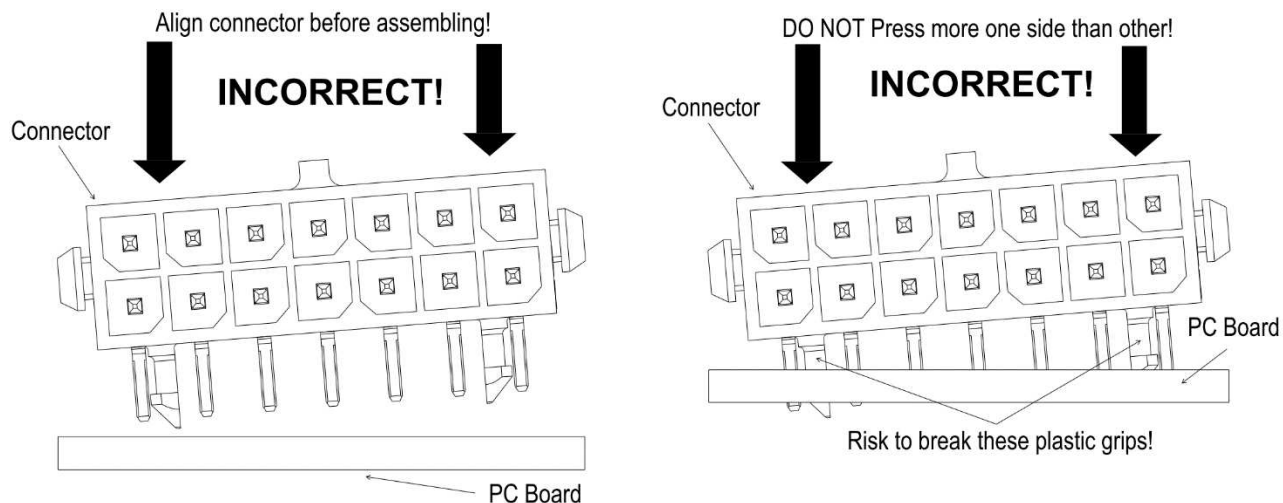

### 3.15. Strain Relief and Wire Dress

If required, wires can be bundled together and supported with cable ties. Wires must not be stretched or confined in any way that would restrict the floating action of the contacts. Therefore, the wires must remain perpendicular to the connector and avoid an excessively sharp bend radius. The minimum distance for the cable tie, measured from the wire end of the connector to the cable tie is shown in Figure 18.

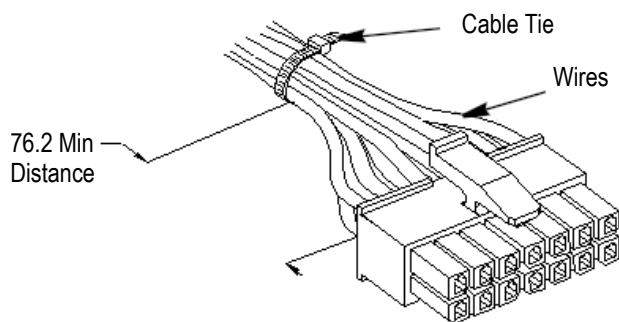

Figure 18

### 3.16. Repair

Damaged connectors must be removed, discarded, and replaced.

1. The connectors must be unmated by releasing the locking latch on the receptacle from the locking tab on the pin header and pulling the receptacle straight out.
2. Damaged or worn crimp type contacts may be replaced provided there is sufficient slack, after re-stripping the wire, to insert the new contact into the receptacle. An extraction tool must be used to remove individual contacts from the receptacle.
3. Pin headers will require standard de-soldering of all contact solder tines. Individual solder type contacts cannot be replaced.

## 4. QUALIFICATION

Micro MATE-N-LOK connectors are Recognized by Underwriters Laboratories Inc. (UL) in File E28476, and Certified by CSA International in File LR7189.

## 5. TOOLING

Tooling part numbers and instructional material packaged (if available) with the tooling are shown in Figure 19.

### 5.1. Extraction and Lance Reset Tool

The extraction and lance reset tool is designed to remove contacts from the receptacles by releasing the contact locking lance from the housing without overstressing the contact. This tool can also be used to reset locking lances that have been deformed.

### 5.2. Hand Crimping Tool

The hand crimping tools accommodate the full wire size range for terminating crimp type contacts. These tools are designed for prototype and low-volume application of loose piece form contacts.

### 5.3. Robotic Equipment

For automatic machine placement, a pc board support must be used to prevent bowing of the pc board during the placement of contacts and boardlocks on the board. It should have flat surfaces with holes or a channel large enough and deep enough to receive the contacts and boardlocks. The robotic equipment must have a true position accuracy tolerance to properly locate the contacts. This includes gripper and fixture tolerances as well as equipment repeatability. It must use the contact datum surfaces detailed on the customer drawing to ensure reliable placement.

### 5.4. Power Unit

**NOTE**

*Modified designs and additional tooling concepts may be available to meet other application requirements. Machines have been designed for a variety of application requirements. For assistance in setting up prototype and production line equipment, call the Tooling Assistance Center at the number at the bottom of page 1.*

#### A. Applicator

The applicators are designed to crimp strip form contacts onto pre-stripped wire, and provides for high volume, heavy duty production requirements. These applicators accept interchangeable crimping dies and must be installed onto a power unit.

#### B. Semi-Automatic Machine

The AMP-O-LECTRIC machine is an electrical power unit designed for terminating pre-stripped wires to reel-fed contacts. It is designed to be bench mounted and used for high volume applications.

#### C. Automatic Machine

These power units provide the force required to drive applicators for crimping tape-mounted contacts. They can be set up to automatically measure, cut, strip, and terminate wire. They provide for high volume, heavy duty production requirements. The AMPOMATOR CLS IV+ machine is an electrical power unit designed to be floor standing.

**Extraction and Lance  
Reset Tool**

**Rec 843996-6  
Tab 1586344-1**

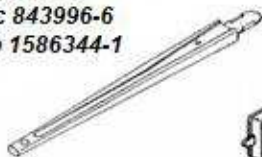

**Hand Crimping Tool  
(See Table)**



**Heavy Duty Miniature  
Quick-Change  
Applicators (Side-Feed  
Type) (See Table)**

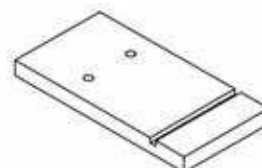
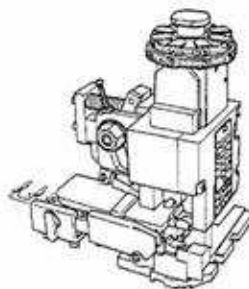

**PC Board Support  
(Must Be Custom Made)**

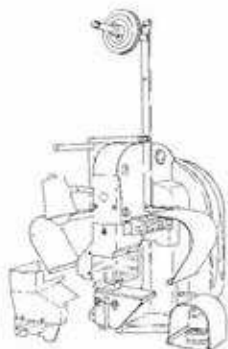

**AMP-O-LECTRIC Model "K"  
Terminator Machine  
565435-5**

**ELT Machine 1338600-[]  
with Optional Stripping  
Module**

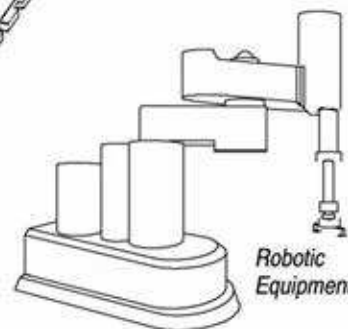
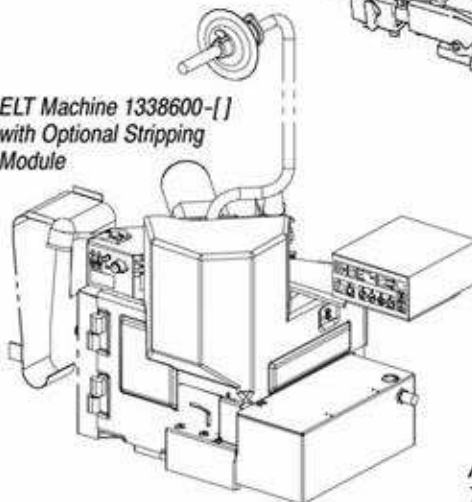

**Robotic  
Equipment**

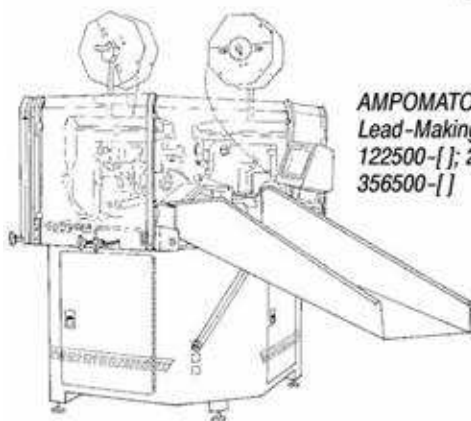

**AMPOMATOR CLS  
Lead-Making Machines  
122500-[]; 217500-[];  
356500-[]**

**AMP-O-LECTRIC Model "G"  
Terminating Machine 354500-[]  
with Optional Stripping Module**

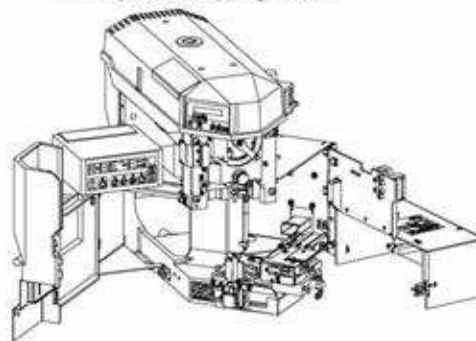

| WIRE SIZE RANGE (AWG)       | HAND CRIMPING TOOL | APPLICATOR (408-8040) FOR                   |  |                                   |                            |
|-----------------------------|--------------------|---|--|-----------------------------------|----------------------------|
|                             |                    | AMP-O-LECTRIC MODEL "K" TERMINATING MACHINE | AMP-O-LECTRIC MODEL "G" AND ELT TERMINATING MACHINES | AMPOMATOR CLS LEAD-MAKING MACHINE | OCEAN SIDE FEED APPLICATOR |
| 30-26                       | 91502-1            | 680894-2 (Rec)                              | 680894-3 (Rec)                                       | 680894-1‡ (Rec)                   | 2151142-1 (Rec)            |
|                             |                    | 1385377-2 (Plug)                            | 1385377-3 (Plug)                                     | 1385377-1 (Plug)                  | 2836146-1 (Plug)           |
| 24-20                       | 91501-1            | 680893-2 (Rec)                              | 680893-3 (Rec)                                       | 680893-1 (Rec)                    | 2151022-1 (Rec)            |
|                             |                    | 1385194-2 (Plug)                            | 1385194-3 (Plug)                                     | 1385194-1 (Plug)                  | 2151616-1 (Plug)           |
| 24-20                       | ---                | ---   | ---  | ---                               | 2837550-1 (Rec)            |
| 22-18                       | 2217299-1          | ---   | ---  | ---                               | 2266495-1 (Rec)            |
| 0.35 / 0.50 mm <sup>2</sup> | ---                | ---   | ---  | ---                               | 2151022-1 (Rec)            |

‡ Processes wire size 26 AWG only.

Figure 19

## 6. PACKAGING

This topic has only the goal to inform customer the kind of packaging used for each part number and its reeling direction when used tape & reel. There is no intention to show dimensions or details of packaging in this specification. This document must be just an orientation to customer. If there is a need for the customer to know the details, then engineering must be contacted.

### A - Tray

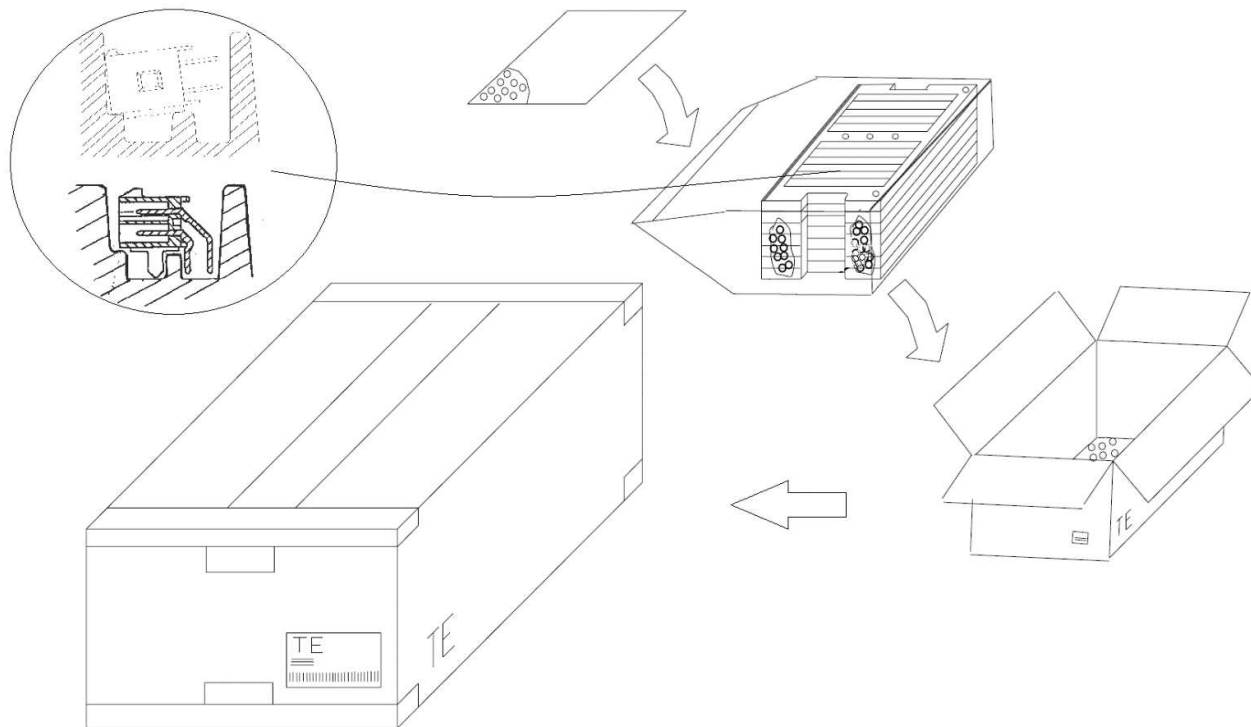

### B - Tape & Reel

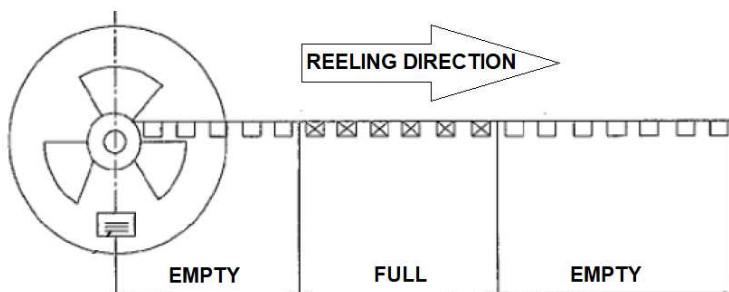

### C - Tape & Reel

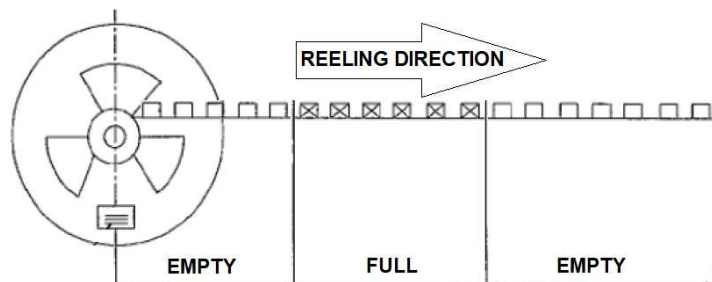

Reeling direction identification

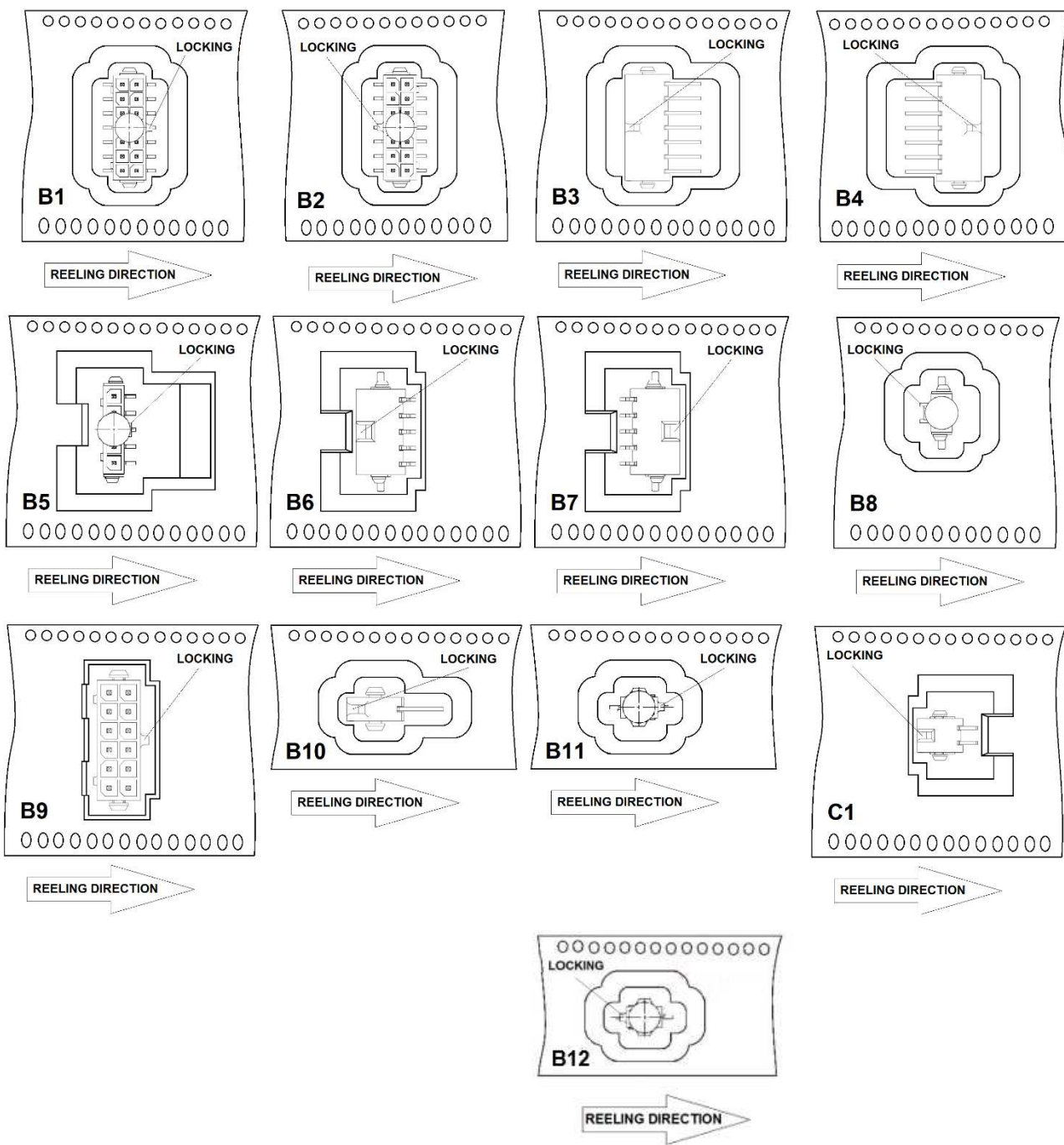

## Moisture Sensitive Level and Reeling Identification

| PNs / Identification | Dashes                    | MSL Level | A | B1 | B2 | B3 | B4 | B5 | B6 | B7 | B8 | B9 | B 10 | B 11 | B 12 | C1 |
|----------------------|---------------------------|-----------|---|----|----|----|----|----|----|----|----|----|------|------|------|----|
| 794618               | all                       | 1         | X |    |    |    |    |    |    |    |    |    |      |      |      |    |
| 794619               | all                       | 1         | X |    |    |    |    |    |    |    |    |    |      |      |      |    |
| 794620               | all                       | 1         | X |    |    |    |    |    |    |    |    |    |      |      |      |    |
| 794620               | 7-...-2                   | 1         |   |    |    | X  |    |    |    |    |    |    |      |      |      |    |
| 794621               | all                       | 2         |   |    |    | X  |    |    |    |    |    |    |      |      |      |    |
| 794621               | 3-...-2                   | 2         |   |    |    |    |    |    |    |    |    |    | X    |      |      |    |
| 794622               | all                       | 2         |   |    |    | X  |    |    |    |    |    |    |      |      |      |    |
| 794622               | 3-...-2                   | 2         |   |    |    |    |    |    |    |    |    |    | X    |      |      |    |
| 794623               | all                       | 2         |   |    |    | X  |    |    |    |    |    |    |      |      |      |    |
| 794623               | 3-...-2                   | 2         |   |    |    |    |    |    |    |    |    |    | X    |      |      |    |
| 794624               | all                       | 2         |   |    |    | X  |    |    |    |    |    |    |      |      |      |    |
| 794624               | 3-...-2                   | 2         |   |    |    |    |    |    |    |    |    |    | X    |      |      |    |
| 794625               | all                       | 2         |   |    |    | X  |    |    |    |    |    |    |      |      |      |    |
| 794625               | 3-...-2                   | 2         |   |    |    |    |    |    |    |    |    |    | X    |      |      |    |
| 794626               | all                       | 2         |   |    |    | X  |    |    |    |    |    |    |      |      |      |    |
| 794626               | 3-...-2                   | 2         |   |    |    |    |    |    |    |    |    |    | X    |      |      |    |
| 794627               | all                       | 2         |   |    |    | X  |    |    |    |    |    |    |      |      |      |    |
| 794627               | 3-...-2                   | 2         |   |    |    |    |    |    |    |    |    |    | X    |      |      |    |
| 794628               | all                       | 2         |   |    |    | X  |    |    |    |    |    |    |      |      |      |    |
| 794628               | 3-...-2                   | 2         |   |    |    |    |    |    |    |    |    |    | X    |      |      |    |
| 794629               | all                       | 2         |   |    |    | X  |    |    |    |    |    |    |      |      |      |    |
| 794629               | 3-...-2                   | 2         |   |    |    |    |    |    |    |    |    |    | X    |      |      |    |
| 794629               | 6-...-4, 6-...-8, 7-...-2 | 2         |   |    |    |    | X  |    |    |    |    |    |      |      |      |    |
| 794630               | all                       | 1         | X |    |    |    |    |    |    |    |    |    |      |      |      |    |
| 794631               | all                       | 1         | X |    |    |    |    |    |    |    |    |    |      |      |      |    |
| 794632               | all                       | 1         | X |    |    |    |    |    |    |    |    |    |      |      |      |    |
| 794633               | all                       | 1         |   | X  |    |    |    |    |    |    |    |    |      |      |      |    |
| 794633               | 3-...-2                   | 1         |   |    |    |    |    |    |    |    |    |    |      | X    |      |    |
| 794634               | all                       | 1         |   | X  |    |    |    |    |    |    |    |    |      |      |      |    |
| 794634               | 3-...-2                   | 1         |   |    |    |    |    |    |    |    |    |    |      | X    |      |    |
| 794635               | all                       | 1         |   | X  |    |    |    |    |    |    |    |    |      |      |      |    |
| 794635               | 7-...-4                   | 1         |   |    | X  |    |    |    |    |    |    |    |      |      |      |    |
| 794635               | 3-...-2                   | 1         |   |    |    |    |    |    |    |    |    |    |      | X    |      |    |
| 794636               | all                       | 1         |   | X  |    |    |    |    |    |    |    |    |      |      |      |    |
| 794636               | 3-...-2                   | 1         |   |    |    |    |    |    |    |    |    |    |      | X    |      |    |
| 794636               | 6-...-6                   | 1         |   |    | X  |    |    |    |    |    |    |    |      |      |      |    |
| 794637               | all                       | 1         |   | X  |    |    |    |    |    |    |    |    |      |      |      |    |
| 794637               | 3-...-2                   | 1         |   |    |    |    |    |    |    |    |    |    |      | X    |      |    |
| 794638               | all                       | 1         |   | X  |    |    |    |    |    |    |    |    |      |      |      |    |
| 794638               | 3-...-2                   | 1         |   |    |    |    |    |    |    |    |    |    |      | X    |      |    |
| 794677               | all                       | 1         | X |    |    |    |    |    |    |    |    |    |      |      |      |    |
| 794678               | all                       | 1         | X |    |    |    |    |    |    |    |    |    |      |      |      |    |
| 794679               | all                       | 1         | X |    |    |    |    |    |    |    |    |    |      |      |      |    |

| PNs / Identification | Dashes           | MSL Level | A | B1 | B2 | B3 | B4 | B5 | B6 | B7 | B8 | B9 | B 10 | B 11 | B 12 | C1 |
|----------------------|------------------|-----------|---|----|----|----|----|----|----|----|----|----|------|------|------|----|
| 794680               | all              | 1         | X |    |    |    |    |    |    |    |    |    |      |      |      |    |
| 794681               | all              | 1         | X |    |    |    |    |    |    |    |    |    |      |      |      |    |
| 794682               | all              | 1         | X |    |    |    |    |    |    |    |    |    |      |      |      |    |
| 794930               | 2-...-4          | 1         | X |    |    |    |    |    |    |    |    |    |      |      |      |    |
| 1445050              | all              | 1         | X |    |    |    |    |    |    |    |    |    |      |      |      |    |
| 1445051              | all              | 1         | X |    |    |    |    |    |    |    |    |    |      |      |      |    |
| 1445052              | all              | 1         |   |    |    |    |    | X  |    |    |    |    |      |      |      |    |
| 1445053              | all              | 1         |   |    |    |    |    | X  |    |    |    |    |      |      |      |    |
| 1445054              | all              | 1         | X |    |    |    |    |    |    |    |    |    |      |      |      |    |
| 1445055              | all              | 1         | X |    |    |    |    |    |    |    |    |    |      |      |      |    |
| 1445056              | all              | 1         |   |    |    |    |    |    | X  |    |    |    |      |      |      |    |
| 1445057              | all              | 1         |   |    |    |    |    |    | X  |    |    |    |      |      |      |    |
| 1445084              | all              | 1         | X |    |    |    |    |    |    |    |    |    |      |      |      |    |
| 1445085              | all              | 1         | X |    |    |    |    |    |    |    |    |    |      |      |      |    |
| 1445086              | all              | 1         |   |    |    |    |    | X  |    |    |    |    |      |      |      |    |
| 1445087              | all              | 1         |   |    |    |    |    | X  |    |    |    |    |      |      |      |    |
| 1445088              | all              | 1         | X |    |    |    |    |    |    |    |    |    |      |      |      |    |
| 1445089              | all              | 1         | X |    |    |    |    |    |    |    |    |    |      |      |      |    |
| 1445090              | all              | 1         |   |    |    |    |    |    | X  |    |    |    |      |      |      |    |
| 1445091              | all              | 1         |   |    |    |    |    |    | X  |    |    |    |      |      |      |    |
| 1445093              | all              | 1         | X |    |    |    |    |    |    |    |    |    |      |      |      |    |
| 1445094              | all              | 1         | X |    |    |    |    |    |    |    |    |    |      |      |      |    |
| 1445095              | all              | 1         |   |    |    |    |    | X  |    |    |    |    |      |      |      |    |
| 1445096              | all              | 1         |   |    |    |    |    | X  |    |    |    |    |      |      |      |    |
| 1445097              | all              | 1         | X |    |    |    |    |    |    |    |    |    |      |      |      |    |
| 1445098              | all              | 1         | X |    |    |    |    |    |    |    |    |    |      |      |      |    |
| 1445099              | all              | 1         |   |    |    |    |    |    | X  |    |    |    |      |      |      |    |
| 1445100              | all              | 1         |   |    |    |    |    |    | X  |    |    |    |      |      |      |    |
| 1445100              | 6-...-4          | 1         |   |    |    |    |    |    |    | X  |    |    |      |      |      |    |
| 1586835              | 4-...-2          | 1         |   |    | X  |    |    |    |    |    |    |    |      |      |      |    |
| 1586842              | all              | 1         |   |    | X  |    |    |    |    |    |    |    |      |      |      |    |
| 1586842              | 0-...-2          | 1         |   |    |    |    |    |    |    |    |    |    |      |      | X    |    |
| 1740655              | 0-...-4          | 2         |   |    |    |    |    |    |    |    |    |    |      |      |      | X  |
| 1740655              | 3-...-4, 5-...-4 | 2         |   |    |    | X  |    |    |    |    |    |    |      |      |      |    |
| 2029030              | all              | 1         |   |    |    |    |    |    | X  |    |    |    |      |      |      |    |
| 2029031              | 0-...-4          | 1         |   |    |    |    |    | X  |    |    |    |    |      |      |      |    |
| 2029032              | 0-...-2          | 1         |   |    |    |    |    |    |    |    | X  |    |      |      |      |    |
| 2029033              | 0-...-3          | 1         | X |    |    |    |    |    |    |    |    |    |      |      |      |    |
| 2029037              | 0-...-4, 1-...-4 | 1         | X |    |    |    |    |    |    |    |    |    |      |      |      |    |
| 2029076              | all              | 1         |   |    |    |    |    |    | X  |    |    |    |      |      |      |    |
| 2029104              | all              | 1         |   |    |    |    |    |    | X  |    |    |    |      |      |      |    |
| 2029266              | all              | 1         |   |    |    |    |    |    | X  |    |    |    |      |      |      |    |
| 2029304              | 0-...-1          | 1         |   |    |    |    |    |    |    |    |    | X  |      |      |      |    |

---

| <b>PNs /<br/>Identification</b> | <b>Dashes</b>    | <b>MSL<br/>Level</b> | <b>A</b> | <b>B1</b> | <b>B2</b> | <b>B3</b> | <b>B4</b> | <b>B5</b> | <b>B6</b> | <b>B7</b> | <b>B8</b> | <b>B9</b> | <b>B<br/>10</b> | <b>B<br/>11</b> | <b>B<br/>12</b> | <b>C1</b> |
|---------------------------------|------------------|----------------------|----------|-----------|-----------|-----------|-----------|-----------|-----------|-----------|-----------|-----------|-----------------|-----------------|-----------------|-----------|
| 2315124                         | 4-...-0, 4-...-2 | 1                    |          | X         |           |           |           |           |           |           |           |           |                 |                 |                 |           |
| 2372389                         | all              | 1                    | X        |           |           |           |           |           |           |           |           |           |                 |                 |                 |           |
| 2421777                         | All              | 1                    |          |           |           |           |           |           |           |           |           |           |                 |                 | X               |           |
| 2481029                         | All              | 1                    |          | X         |           |           |           |           |           |           |           |           |                 |                 |                 |           |

## 7. VISUAL AID

The illustration below shows a typical application of this product. This illustration should be used by production personnel to ensure a correctly applied product. Applications which DO NOT appear correct should be inspected using the information in the preceding pages of this specification and in the instructional material shipped with the product or tooling.

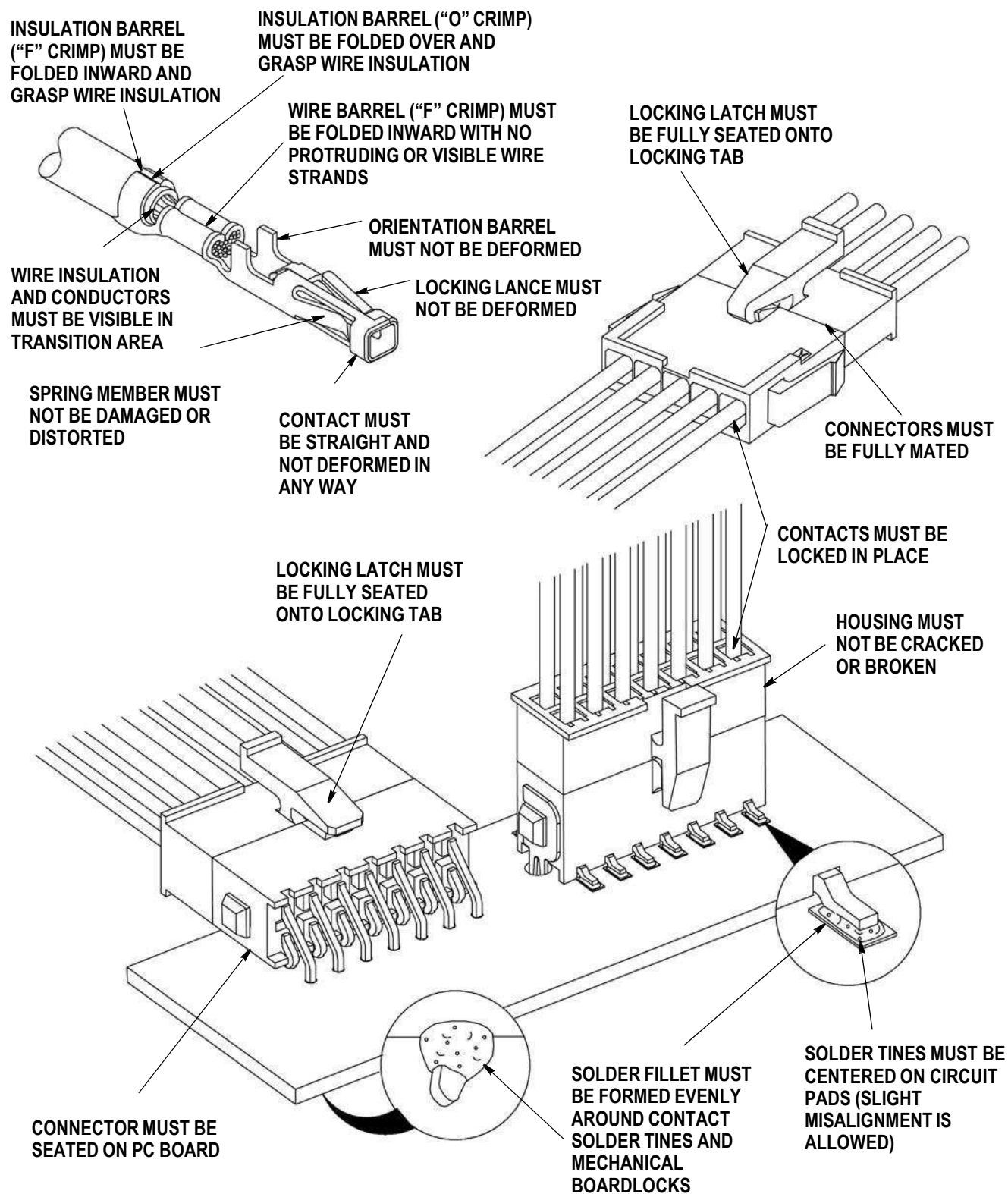

FIGURE 20. VISUAL AID

## Looking for pricing, stock, or lifecycle information?

Click below to explore more details on WIN SOURCE:

 [View 3-794637-8 on WIN SOURCE](#)

 [TE Connectivity](#) Information

## Optimize Your Supply Chain with WIN SOURCE Solutions

-  Global Sourcing Solution
-  Obsolete Management
-  Cost Control Management
-  Shortage Management
-  Alternative Solution
-  Excess Inventory Management