

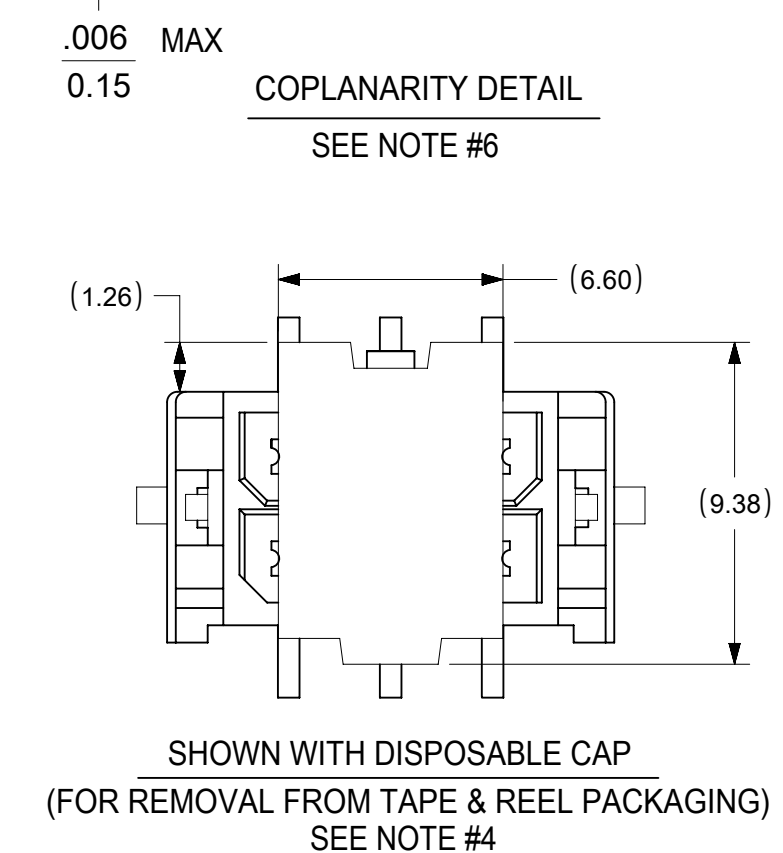

THE DATASHEET OF
0430451018

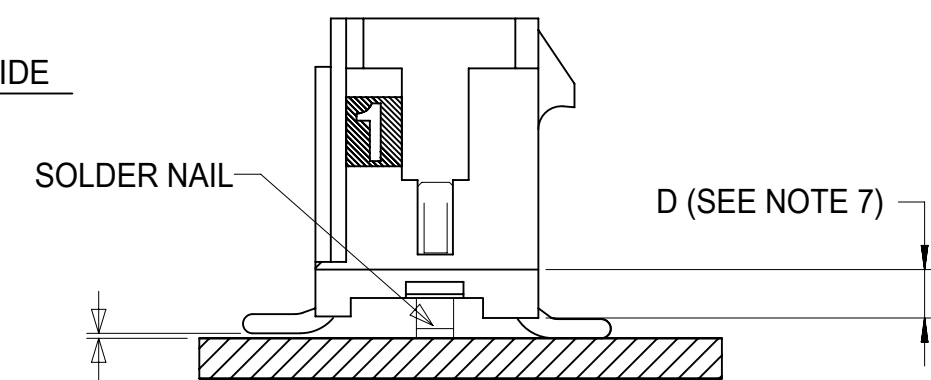

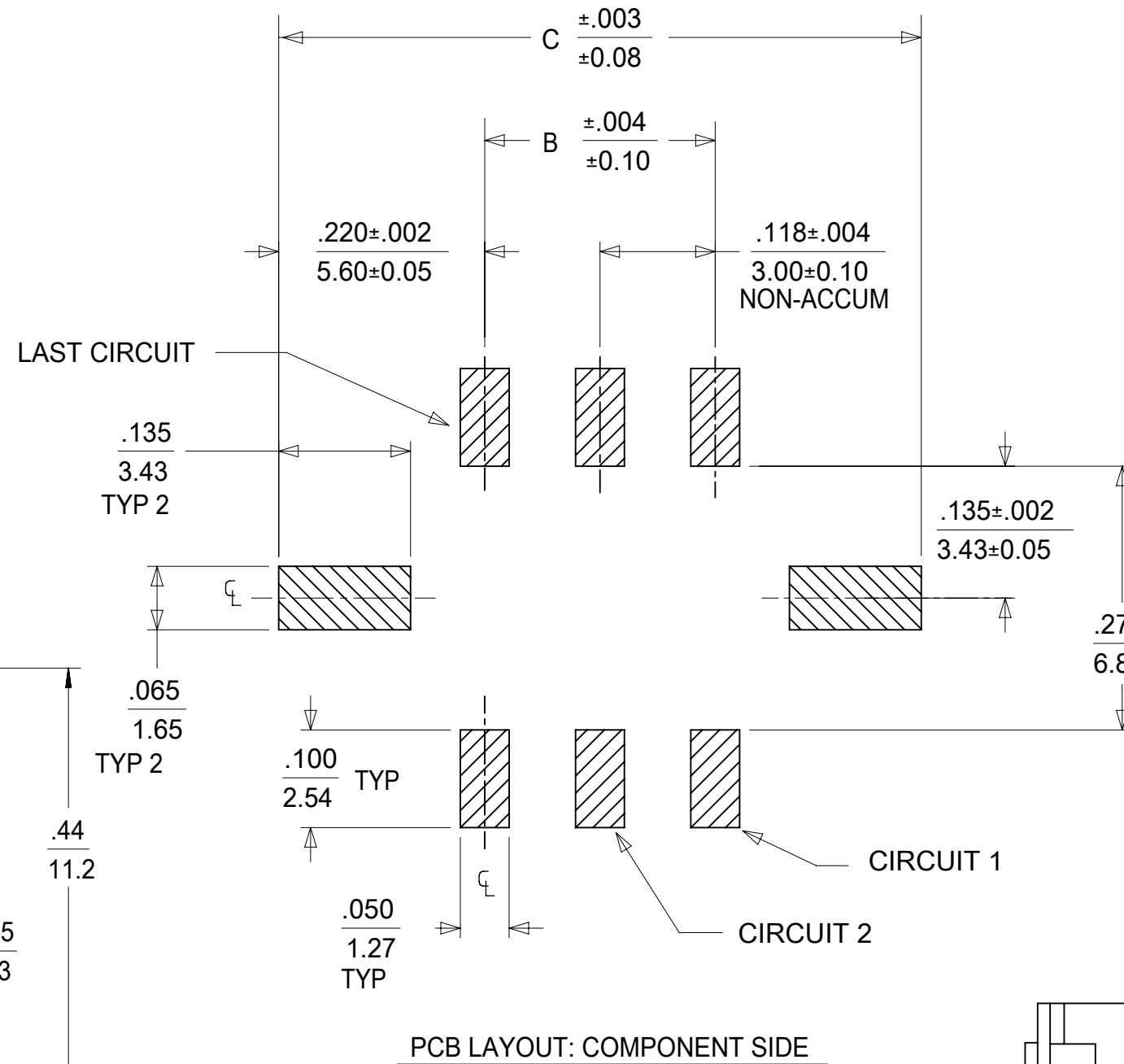
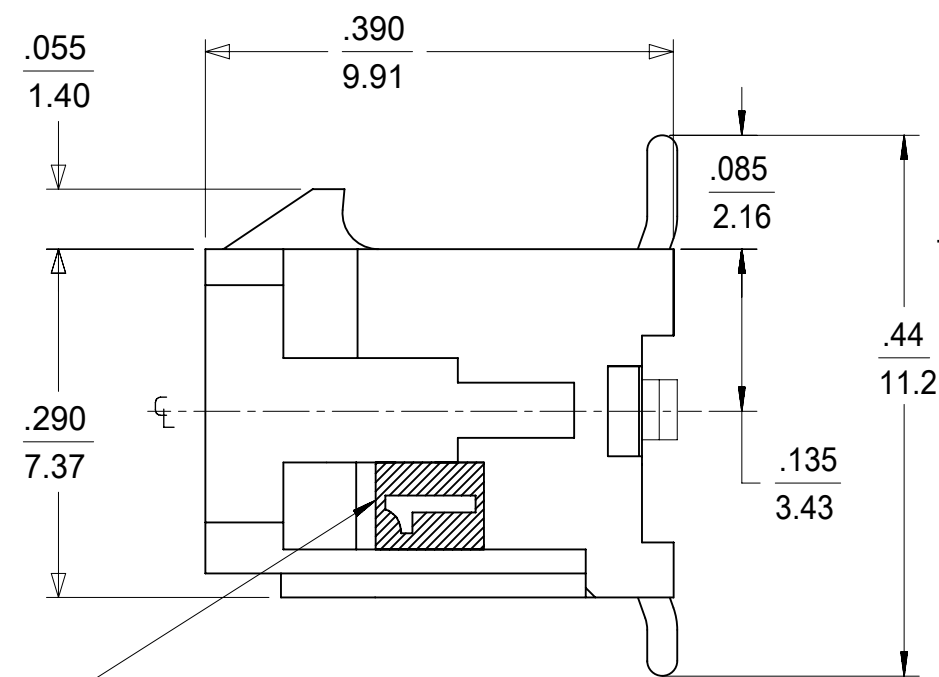
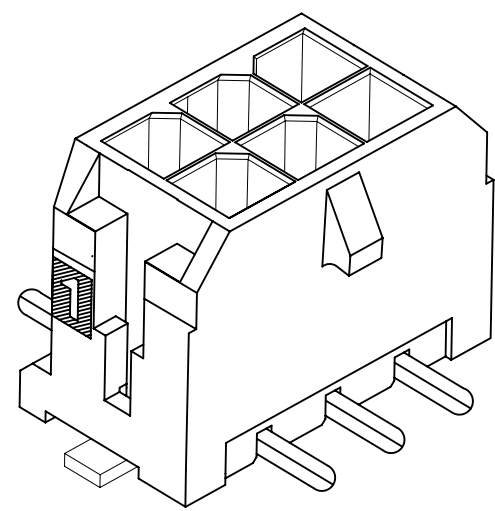
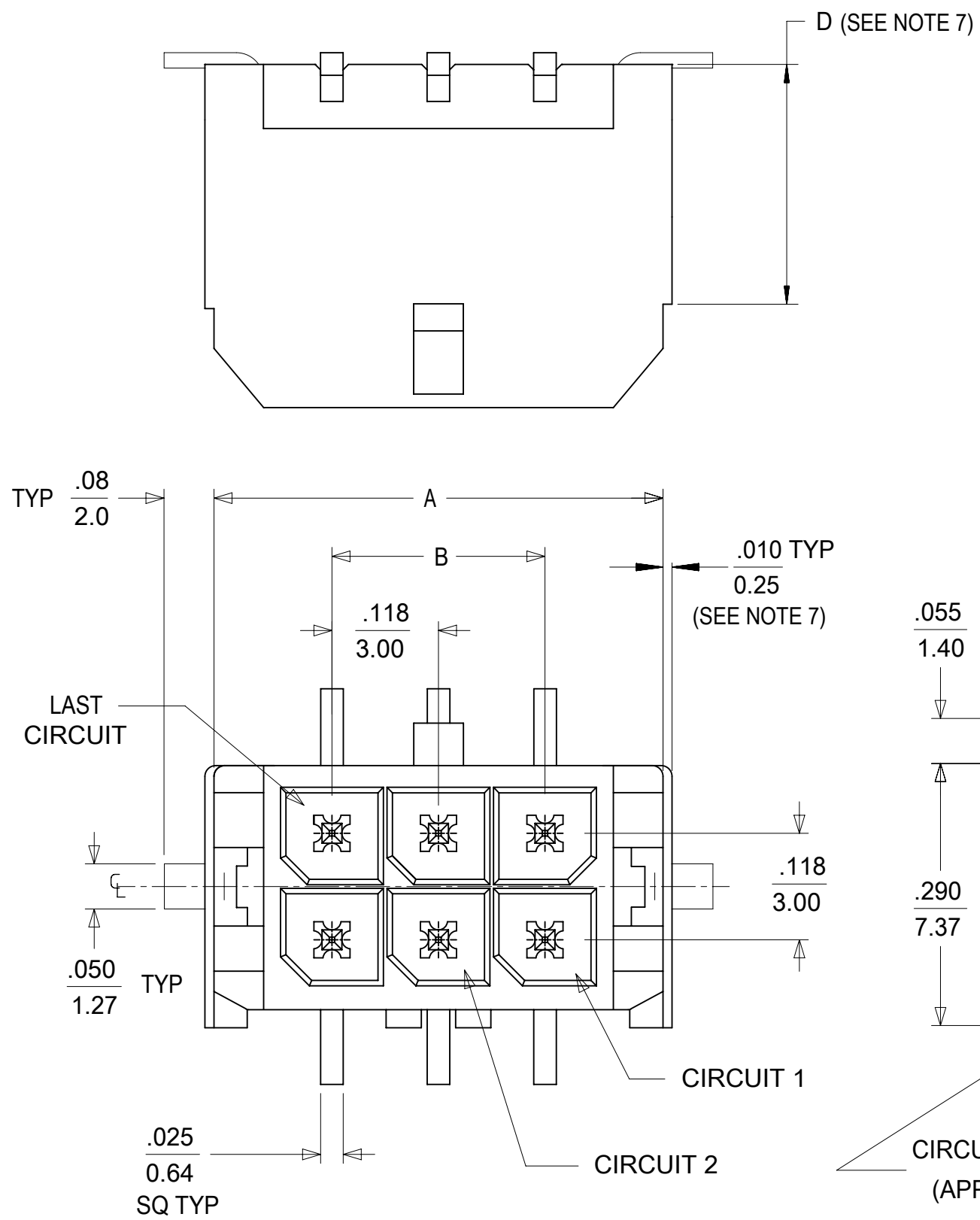

CKTS	A	B	C
02	.262 6.65	NA	.441 11.20
04	.380 9.65	.118 3.00	.559 14.20
06	.498 12.65	.236 6.00	.677 17.20
08	.616 15.65	.354 9.00	.795 20.20
10	.734 18.65	.472 12.00	.913 23.20
12	.852 21.65	.591 15.00	1.031 26.20
14	.970 24.65	.709 18.00	1.150 29.20
16	1.088 27.65	.827 21.00	1.268 32.20
18	1.206 30.65	.945 24.00	1.386 35.20
20	1.325 33.65	1.063 27.00	1.504 38.20
22	1.443 36.65	1.181 30.00	1.622 41.20
24	1.561 39.65	1.299 33.00	1.740 44.20

NOTES:

- HOUSING MATERIAL: GLASS FILLED LIQUID CRYSTAL POLYMER
UL94V-0, COLOR: BLACK
TERMINAL MATERIAL: BRASS ALLOY
- FINISH: A = .000060/(0.00152) MIN. REFLOWED MATTE TIN OVER .000050/(0.00127) MIN. NICKEL PLATE. (FINISH IS BRIGHT IN APPEARANCE, THICKNESS AS APPLIED PRIOR TO REFLOW)
B = .000015/(0.00038) MIN. SELECT GOLD IN CONTACT AREA; .000100/(0.00254) MIN. SELECT MATTE TIN ON SOLDER TAILS; BOTH OVER .000050/(0.00127) MIN. NICKEL PLATE.
C = .000030/(0.00076) MIN. SELECT GOLD IN CONTACT AREA; .000100/(0.00254) MIN. SELECT MATTE TIN ON SOLDER TAILS; BOTH OVER .000050/(0.00127) MIN. NICKEL PLATE.
D = .000100/(0.00254) MIN. MATTE TIN OVER .000050/(0.00127) MIN. NICKEL PLATE.
- PRODUCT SPECIFICATION: PS-43045
- TAPE AND REEL PACK : SEE MOLEX DRAWING 430450002-PK
- MATES WITH MICRO FIT (3.0) RECEPTACLE SERIES 43025
- THE COPLANARITY DIMENSION IS ESTABLISHED BY PLACING THE ASSEMBLY ON A FLAT SURFACE. THE DISTANCE FROM THAT SURFACE TO THE BOTTOM OF ANY TERMINAL OR SOLDER NAIL MUST NOT EXCEED .006/0.15
- CIRCUIT SIZES 2-6: "D" IS 0.265/6.74 FOR .010/0.25 STEP.
CIRCUIT SIZES 8-24: "D" IS .063/1.60 FOR .010/0.25 STEP.
- THIS PART CONFORMS TO CLASS B REQUIREMENTS OF COSMETIC SPECIFICATION PS-45499-002.
- TEXT ON PART IS FOR REFERENCE ONLY. TEXT AND TEXT LOCATION MAY VARY DEPENDING ON PART NUMBER AND/OR TOOL.

	FINISH A	FINISH B	FINISH C	FINISH D
CKTS	MATERIAL NO:	MATERIAL NO:	MATERIAL NO:	MATERIAL NO:
02	43045-0218	43045-0219	43045-0220	43045-0118
04	43045-0418	43045-0419	43045-0420	43045-0318
06	43045-0618	43045-0619	43045-0620	43045-0518
08	43045-0818	43045-0819	43045-0820	43045-0718
10	43045-1018	43045-1019	43045-1020	43045-0918
12	43045-1218	43045-1219	43045-1220	43045-1118
14	43045-1418	43045-1419	43045-1420	43045-1318
16	43045-1618	43045-1619	43045-1620	43045-1518
18	43045-1818	43045-1819	43045-1820	43045-1718
20	43045-2018	43045-2019	43045-2020	43045-1918
22	43045-2218	43045-2219	43045-2220	43045-2118
24	43045-2418	43045-2419	43045-2420	43045-2318

THIS DRAWING CONTAINS INFORMATION THAT IS PROPRIETARY TO MOLEX ELECTRONIC TECHNOLOGIES, LLC AND SHOULD NOT BE USED WITHOUT WRITTEN PERMISSION

DIMENSION UNITS	SCALE	CURRENT REV DESC:	molex		
mm	NTS				
GENERAL TOLERANCES (UNLESS SPECIFIED)			MICRO FIT (3.0) VERTICAL SMT, NAILS DUAL ROW HEADER		
	MM	INCH			
4 PLACES	±	±	PRODUCT CUSTOMER DRAWING		
3 PLACES	±	± 0.01			
2 PLACES	± 0.25	± 0.014	DOCUMENT NUMBER		
1 PLACE	± 0.36	±			
0 PLACES	±	±	SD-43045-007		
ANGULAR TOL	± 0.5°				
DRAFT WHERE APPLICABLE MUST REMAIN WITHIN DIMENSIONS			DOC TYPE DOC PART REVISION		
THIRD ANGLE PROJECTION			PSD 001 G5		
DRAWING SERIES			MATERIAL NUMBER CUSTOMER SHEET NUMBER		
C-SIZE 43045			SEE CHART GENERAL MARKET 1 OF 1		

Looking for pricing, stock, or lifecycle information?

Click below to explore more details on WIN SOURCE:

 [View 0430451018 on WIN SOURCE](#)

 [Molex, LLC Information](#)

Optimize Your Supply Chain with WIN SOURCE Solutions

-  Global Sourcing Solution
-  Obsolete Management
-  Cost Control Management
-  Shortage Management
-  Alternative Solution
-  Excess Inventory Management