

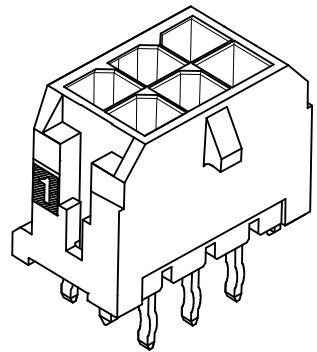

**THE DATASHEET OF**  
**0430450614**

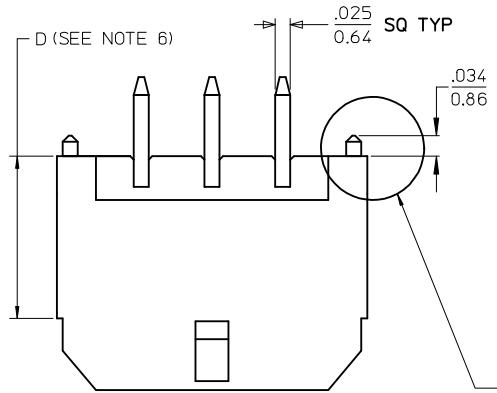



NOTE : (2) POLARIZATION PEGS ARE SHOWN, HOWEVER, ASSEMBLIES MAY BE MANUFACTURED WITH (1) PEG ONLY.

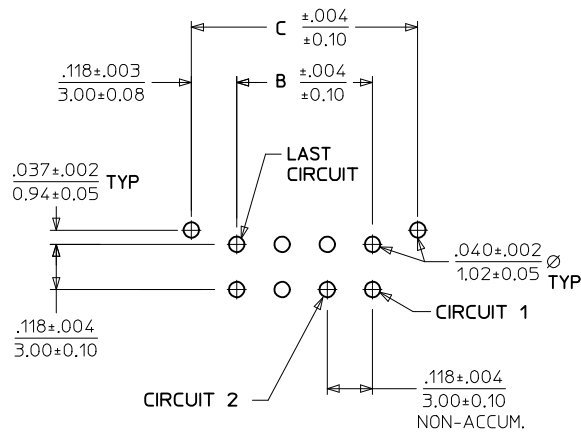

PCB LAYOUT: COMPONENT SIDE  
RECOMMEND PCB THICKNESS: .062/1.57

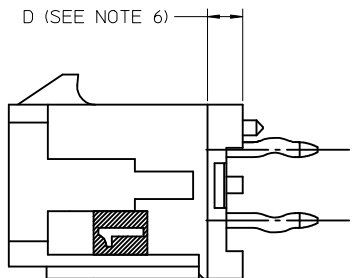
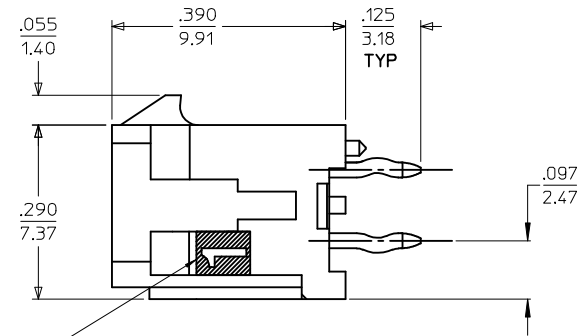
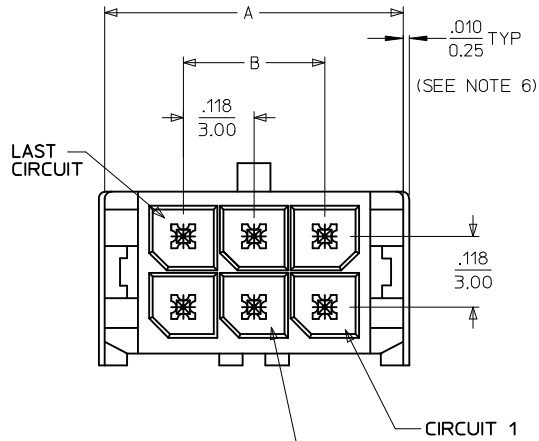

- NOTES:**
- HOUSING MATERIAL: GLASS FILLED LIQUID CRYSTAL POLYMER, UL94V-0, COLOR: BLACK  
TERMINAL MATERIAL: BRASS ALLOY
  - FINISH: A = .000060/(0.00152) MIN. REFLOWED MATTE TIN OVER .000050/(0.00127) MIN. NICKEL PLATE. (FINISH IS BRIGHT IN APPEARANCE. THICKNESS AS APPLIED PRIOR TO REFLOW)  
B = .000015/(0.00038) MIN. SELECT GOLD IN CONTACT AREA, .000100/(0.00254) MIN. SELECT MATTE TIN ON SOLDER TAILS, BOTH OVER .000050/(0.00127) MIN. NICKEL PLATE.  
C = .000030/(0.00076) MIN. SELECT GOLD IN CONTACT AREA, .000100/(0.00254) MIN. SELECT MATTE TIN ON SOLDER TAILS, BOTH OVER .000050/(0.00127) MIN. NICKEL PLATE.  
D = .000100/(0.00254) MIN. MATTE TIN OVER .000050/(0.00127) MIN. NICKEL PLATE.

- PRODUCT SPECIFICATION: PS-43045
- TRAY PACKAGED: SEE MOLEX DRAWING PK-70873-0314
- MATES WITH MICRO FIT (3.0) RECEPTACLE SERIES 43025
- CIRCUIT SIZES 2-6: "D" IS 0.265/6.74 FOR .010/0.25 STEP. CIRCUIT SIZES 8-24: "D" IS 0.063/1.60 FOR .010/0.25 STEP.
- THIS PART CONFORMS TO CLASS B REQUIREMENTS OF COSMETIC SPECIFICATION PS-45499-002.

CKTS	FINISH A	FINISH B	FINISH C	FINISH D
	MATERIAL NO:	MATERIAL NO:	MATERIAL NO:	MATERIAL NO:
02	43045-0212	43045-0213	43045-0214	43045-0311
04	43045-0412	43045-0413	43045-0414	43045-0511
06	43045-0612	43045-0613	43045-0614	43045-0711
08	43045-0812	43045-0813	43045-0814	43045-0911
10	43045-1012	43045-1013	43045-1014	43045-1111
12	43045-1212	43045-1213	43045-1214	43045-1311
14	43045-1412	43045-1413	43045-1414	43045-1511
16	43045-1612	43045-1613	43045-1614	43045-1711
18	43045-1812	43045-1813	43045-1814	43045-1911
20	43045-2012	43045-2013	43045-2014	43045-2111
22	43045-2212	43045-2213	43045-2214	43045-2311
24	43045-2412	43045-2413	43045-2414	43045-2511

FINISH A & D EC NO: UCP2016-4586 DRAWN: JFOX 2015/12/10 CHKD: SSOUSEK 2015/12/10 APPR: FSM LTH 2016/08/23	QUALITY SYMBOLS	GENERAL TOLERANCES (UNLESS SPECIFIED)	DIMENSION STYLE	SCALE	DESIGN UNITS	THIRD ANGLE PROJECTION
	▽=0	mm INCH	IN/MM	---	METRIC	
	▽=0	4 PLACES ± --- ± ---	DRAWN BY DATE			TITLE
	▽=0	3 PLACES ± --- ± .010	SAMIEC 2000/03/15			MICRO FIT (3.0) DUAL ROW VERTICAL THRU HOLE HEADER ASS'Y
	2 PLACES ± 0.25 ± .014	CHECKED BY DATE				molex
	1 PLACE ± 0.36 ± ---	SSOUSEK 2016/06/01				
	0 PLACE ± --- ± ---	APPROVED BY DATE				
		FSM LTH 2016/08/23				
	ANGULAR ±1/2°	MATERIAL NO.				
	DRAFT WHERE APPLICABLE MUST REMAIN WITHIN DIMENSIONS	SEE CHART			DOCUMENT NO.	
					SD-43045-005	
						SHEET NO.
						1 OF 1



## Looking for pricing, stock, or lifecycle information?

Click below to explore more details on WIN SOURCE:

 [View 0430450614 on WIN SOURCE](#)

 [Molex, LLC Information](#)

## Optimize Your Supply Chain with WIN SOURCE Solutions

-  Global Sourcing Solution
-  Obsolete Management
-  Cost Control Management
-  Shortage Management
-  Alternative Solution
-  Excess Inventory Management