

YXG シリーズ
SERIES

新規採用非推奨品
NOT recommended for new designs

105°C 低インピーダンス品
105°C Low Impedance

・105°C 3000~6000時間品。
Load Life : 105°C 3000~6000 hours.

RoHS
compliance



◆規格表/SPECIFICATIONS

項目 Items	特 性 Characteristics																															
カテゴリ温度範囲 Category Temperature Range	-40~+105°C																															
定格電圧範囲 Rated Voltage Range	6.3~100Vdc																															
静電容量許容差 Capacitance Tolerance	±20%(20°C, 120Hz)																															
漏れ電流 Leakage Current (MAX)	$I=0.01CV$ 又は $3\mu A$ のいずれか大なる値以下(定格電圧印加2分後) $I=0.01CV$ or $3\mu A$ whichever is greater. (After 2 minutes) I =漏れ電流(μA) Leakage Current C =静電容量(μF) Capacitance V =定格電圧(Vdc) Rated Voltage																															
損失角の正接 (tan δ) Dissipation Factor (MAX)	<table border="1"> <tr> <td>定格電圧(Vdc) Rated Voltage</td> <td>6.3</td><td>10</td><td>16</td><td>25</td><td>35</td><td>50</td><td>63</td><td>100</td> <td>(20°C, 120Hz)</td> </tr> <tr> <td>tanδ</td> <td>0.22</td><td>0.19</td><td>0.16</td><td>0.14</td><td>0.12</td><td>0.10</td><td>0.09</td><td>0.08</td> <td></td> </tr> </table> <p>1000μFを越えるものは1000μF増す毎に上表の値に0.02を加えた値とする。 When capacitance is over 1000μF, tanδ shall be added 0.02 to the listed value with increase of every 1000μF.</p>		定格電圧(Vdc) Rated Voltage	6.3	10	16	25	35	50	63	100	(20°C, 120Hz)	tan δ	0.22	0.19	0.16	0.14	0.12	0.10	0.09	0.08											
定格電圧(Vdc) Rated Voltage	6.3	10	16	25	35	50	63	100	(20°C, 120Hz)																							
tan δ	0.22	0.19	0.16	0.14	0.12	0.10	0.09	0.08																								
耐 久 性 Endurance	<p>105°C中で右表の時間定格電圧(リップル重量)印加後、下記項目を満足すること。 After applying rated voltage with rated ripple current for specified time at 105°C, the capacitors shall meet the following requirements.</p> <table border="1"> <tr> <td>静電容量変化率 Capacitance Change</td> <td>初期値の±25%以内 Within ±25% of the initial value.</td> <td>ケースサイズ Case Size</td> <td>時間(hrs) Life Time</td> </tr> <tr> <td>損失角の正接 Dissipation Factor</td> <td>規格値の200%以下 Not more than 200% of the specified value.</td> <td>$\phi D \leq 6.3$</td> <td>3000</td> </tr> <tr> <td>漏れ電流 Leakage Current</td> <td>規格値以下 Not more than the specified value.</td> <td>$\phi D = 8$</td> <td>4000</td> </tr> <tr> <td></td> <td></td> <td>$\phi D = 10$</td> <td>5000</td> </tr> <tr> <td></td> <td></td> <td>$\phi D \geq 12.5$</td> <td>6000</td> </tr> </table>		静電容量変化率 Capacitance Change	初期値の±25%以内 Within ±25% of the initial value.	ケースサイズ Case Size	時間(hrs) Life Time	損失角の正接 Dissipation Factor	規格値の200%以下 Not more than 200% of the specified value.	$\phi D \leq 6.3$	3000	漏れ電流 Leakage Current	規格値以下 Not more than the specified value.	$\phi D = 8$	4000			$\phi D = 10$	5000			$\phi D \geq 12.5$	6000										
静電容量変化率 Capacitance Change	初期値の±25%以内 Within ±25% of the initial value.	ケースサイズ Case Size	時間(hrs) Life Time																													
損失角の正接 Dissipation Factor	規格値の200%以下 Not more than 200% of the specified value.	$\phi D \leq 6.3$	3000																													
漏れ電流 Leakage Current	規格値以下 Not more than the specified value.	$\phi D = 8$	4000																													
		$\phi D = 10$	5000																													
		$\phi D \geq 12.5$	6000																													
低温特性 Low Temperature Stability (インピーダンス比) Impedance Ratio (MAX)	<table border="1"> <tr> <td>定格電圧(Vdc) Rated Voltage</td> <td>6.3</td><td>10</td><td>16</td><td>25</td><td>35</td><td>50</td><td>63</td><td>100</td> <td>(120Hz)</td> </tr> <tr> <td>Z(-25°C)/Z(20°C)</td> <td>4</td><td>3</td><td>2</td><td>2</td><td>2</td><td>2</td><td>2</td><td>2</td> <td></td> </tr> <tr> <td>Z(-40°C)/Z(20°C)</td> <td>8</td><td>6</td><td>4</td><td>3</td><td>3</td><td>3</td><td>3</td><td>3</td> <td></td> </tr> </table>		定格電圧(Vdc) Rated Voltage	6.3	10	16	25	35	50	63	100	(120Hz)	Z(-25°C)/Z(20°C)	4	3	2	2	2	2	2	2		Z(-40°C)/Z(20°C)	8	6	4	3	3	3	3	3	
定格電圧(Vdc) Rated Voltage	6.3	10	16	25	35	50	63	100	(120Hz)																							
Z(-25°C)/Z(20°C)	4	3	2	2	2	2	2	2																								
Z(-40°C)/Z(20°C)	8	6	4	3	3	3	3	3																								

◆リップル電流補正係数/
MULTIPLIER FOR RIPPLE CURRENT

周波数(Hz) Frequency		120	1k	10k	100k \leq
係数 Coefficient	6.8~33 μF	0.42	0.70	0.90	1.00
	39~270 μF	0.50	0.73	0.92	1.00
	330~680 μF	0.55	0.77	0.94	1.00
	820~1800 μF	0.60	0.80	0.96	1.00
	2200~18000 μF	0.70	0.85	0.98	1.00

◆寸法図/DIMENSIONS (mm)

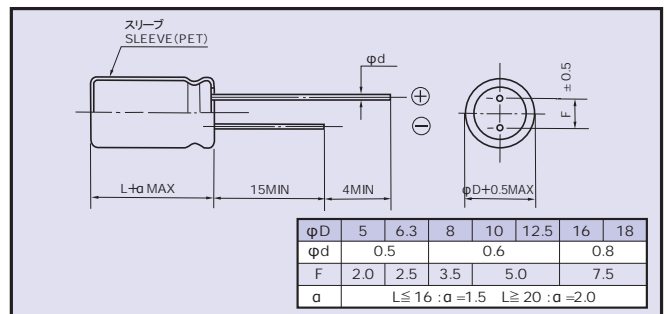

◆呼称方法/PART NUMBER

□□□	YXG	□□□□□	M	□□□	□□	DxL
定格電圧 Rated Voltage	シリーズ名 Series	静電容量 Capacitance	静電容量許容差 Capacitance Tolerance	副記号 Option	リード加工記号 Lead Forming	ケースサイズ Case Size

◆副記号/OPTION

	記号 Code
PETスリーブ PET Sleeve	EFC

◆標準品一覧表 / STANDARD SIZE

定格電圧 Rated Voltage (Vdc)	静電容量 Capacitance (μ F)	外形寸法 Size ϕ D×L(mm)	定格リップル電流 Rated ripple current (mA r.m.s./105°C, 100kHz)	インピーダンス(Ω MAX) Impedance	
				20°C, 100kHz	-10°C, 100kHz
6.3	150	5×11	210	0.58	2.3
	330	6.3×11	340	0.22	0.87
	680	8×11.5	640	0.13	0.52
	820	10×12.5	865	0.080	0.32
	1000	8×16	840	0.087	0.35
	1200	8×20	1050	0.069	0.27
	1200	10×16	1210	0.060	0.24
	1500	10×20	1400	0.046	0.18
	1800	12.5×16	1450	0.049	0.16
	2200	10×23	1650	0.042	0.17
	2700	10×28	1910	0.031	0.12
	2700	16×16	1940	0.042	0.12
	3300	12.5×20	1900	0.035	0.12
	3900	12.5×25	2230	0.027	0.089
	3900	18×16	2210	0.043	0.11
	4700	12.5×30	2650	0.024	0.078
	5600	12.5×35	2880	0.020	0.065
	5600	16×20	2530	0.027	0.078
	6800	12.5×40	3350	0.017	0.056
	6800	16×25	2930	0.021	0.060
6800	18×20	2860	0.026	0.067	
8200	16×31.5	3450	0.017	0.050	
10000	16×35.5	3610	0.015	0.044	
10000	18×25	3140	0.019	0.049	
12000	16×40	4080	0.013	0.038	
12000	18×31.5	4170	0.015	0.040	
15000	18×35.5	4220	0.014	0.038	
18000	18×40	4280	0.012	0.032	
16	56	5×11	210	0.58	2.3
	120	6.3×11	340	0.22	0.87
	330	8×11.5	640	0.13	0.52
	470	8×16	840	0.087	0.35
	470	10×12.5	865	0.080	0.32
	680	8×20	1050	0.069	0.27
	680	10×16	1210	0.060	0.24
	1000	10×20	1400	0.046	0.18
	1000	12.5×16	1450	0.049	0.16
	1200	10×23	1650	0.042	0.17
	1500	10×28	1910	0.031	0.12
	1500	12.5×20	1900	0.035	0.12
	1500	16×16	1940	0.042	0.12
	2200	12.5×25	2230	0.027	0.089
	2200	18×16	2210	0.043	0.11
	2700	12.5×30	2650	0.024	0.078
	2700	16×20	2530	0.027	0.078
	3300	12.5×35	2880	0.020	0.065
	3900	12.5×40	3350	0.017	0.056
	3900	16×25	2930	0.021	0.060
3900	18×20	2860	0.026	0.067	
4700	16×31.5	3450	0.017	0.050	
4700	18×25	3140	0.019	0.049	
5600	16×35.5	3610	0.015	0.044	
5600	18×31.5	4170	0.015	0.040	
6800	16×40	4080	0.013	0.038	
8200	18×35.5	4220	0.014	0.038	
10000	18×40	4280	0.012	0.032	
10	100	5×11	210	0.58	2.3
	220	6.3×11	340	0.22	0.87
	470	8×11.5	640	0.13	0.52
	680	8×16	840	0.087	0.35
	680	10×12.5	865	0.080	0.32
	1000	8×20	1050	0.069	0.27
	1000	10×16	1210	0.060	0.24
	1200	10×20	1400	0.046	0.18
	1500	10×23	1650	0.042	0.17
	1500	12.5×16	1450	0.049	0.16
	2200	10×28	1910	0.031	0.12
	2200	12.5×20	1900	0.035	0.12
	2200	16×16	1940	0.042	0.12
	2700	18×16	2210	0.043	0.11
	3300	12.5×25	2230	0.027	0.089
	3900	12.5×30	2650	0.024	0.078
	3900	16×20	2530	0.027	0.078
	4700	12.5×35	2880	0.020	0.065
	5600	12.5×40	3350	0.017	0.056
	5600	16×25	2930	0.021	0.060
5600	18×20	2860	0.026	0.067	
6800	16×31.5	3450	0.017	0.050	
6800	18×25	3140	0.019	0.049	
8200	16×35.5	3610	0.015	0.044	
8200	18×31.5	4170	0.015	0.040	
10000	16×40	4080	0.013	0.038	
10000	18×35.5	4220	0.014	0.038	
12000	18×40	4280	0.012	0.032	
25	47	5×11	210	0.58	2.3
	100	6.3×11	340	0.22	0.87
	220	8×11.5	640	0.13	0.52
	330	8×16	840	0.087	0.35
	330	10×12.5	865	0.080	0.32
	470	8×20	1050	0.069	0.27
	470	10×16	1210	0.060	0.24
	680	10×20	1400	0.046	0.18
	680	12.5×16	1450	0.049	0.16
	820	10×23	1650	0.042	0.17
	1000	10×28	1910	0.031	0.12
	1000	12.5×20	1900	0.035	0.12
	1000	16×16	1940	0.042	0.12
	1200	18×16	2210	0.043	0.11
	1500	12.5×25	2230	0.027	0.089
	1800	12.5×30	2650	0.024	0.078
	1800	16×20	2530	0.027	0.078
	2200	12.5×35	2880	0.020	0.065
	2200	18×20	2860	0.026	0.067
	2700	12.5×40	3350	0.017	0.056
2700	16×25	2930	0.021	0.060	
3300	16×31.5	3450	0.017	0.050	
3300	18×25	3140	0.019	0.049	
3900	16×35.5	3610	0.015	0.044	
3900	18×31.5	4170	0.015	0.040	
4700	16×40	4080	0.013	0.038	
4700	18×35.5	4220	0.014	0.038	
5600	18×40	4280	0.012	0.032	

◆標準品一覧表 / STANDARD SIZE

定格電圧 Rated Voltage (Vdc)	静電容量 Capacitance (μ F)	外形寸法 Size ϕ D×L(mm)	定格リップル電流 Rated ripple current (mA r.m.s./105°C, 100kHz)	インピーダンス(Ω MAX) Impedance	
				20°C, 100kHz	-10°C, 100kHz
35	33	5×11	210	0.58	2.3
	56	6.3×11	340	0.22	0.87
	150	8×11.5	640	0.13	0.52
	220	8×16	840	0.087	0.35
	220	10×12.5	865	0.080	0.32
	270	8×20	1050	0.069	0.27
	330	10×16	1210	0.060	0.24
	470	10×20	1400	0.046	0.18
	470	12.5×16	1450	0.049	0.16
	560	10×23	1650	0.042	0.17
	680	10×28	1910	0.031	0.12
	680	12.5×20	1900	0.035	0.12
	680	16×16	1940	0.042	0.12
	1000	12.5×25	2230	0.027	0.089
	1000	18×16	2210	0.043	0.11
	1200	12.5×30	2650	0.024	0.078
	1200	16×20	2530	0.027	0.078
	1500	12.5×35	2880	0.020	0.065
	1800	12.5×40	3350	0.017	0.056
	1800	16×25	2930	0.021	0.060
1800	18×20	2860	0.026	0.067	
2200	16×31.5	3450	0.017	0.050	
2200	18×25	3140	0.019	0.049	
2700	16×35.5	3610	0.015	0.044	
2700	18×31.5	4170	0.015	0.040	
3300	16×40	4080	0.013	0.038	
3300	18×35.5	4220	0.014	0.038	
3900	18×40	4280	0.012	0.032	
50	22	5×11	180	0.70	2.8
	56	6.3×11	295	0.30	1.2
	100	8×11.5	555	0.17	0.68
	120	8×16	730	0.12	0.48
	150	10×12.5	760	0.12	0.48
	180	8×20	910	0.091	0.36
	220	10×16	1050	0.084	0.34
	270	10×20	1220	0.060	0.24
	270	12.5×16	1260	0.061	0.20
	330	10×23	1440	0.055	0.22
	470	10×28	1690	0.043	0.17
	470	12.5×20	1660	0.045	0.15
	470	16×16	1690	0.055	0.17
	560	12.5×25	1950	0.034	0.11
	560	18×16	1930	0.054	0.15
	680	12.5×30	2310	0.030	0.10
	820	12.5×35	2510	0.025	0.083
	820	16×20	2210	0.034	0.10
	1000	12.5×40	2920	0.021	0.069
	1000	16×25	2555	0.025	0.075
1000	18×20	2490	0.036	0.097	
1200	16×31.5	3010	0.022	0.066	
1200	18×25	2740	0.026	0.070	
1500	16×35.5	3150	0.019	0.057	
1800	16×40	3710	0.016	0.048	
1800	18×31.5	3635	0.021	0.057	
2200	18×35.5	3680	0.017	0.046	
2700	18×40	3800	0.014	0.038	

定格電圧 Rated Voltage (Vdc)	静電容量 Capacitance (μ F)	外形寸法 Size ϕ D×L(mm)	定格リップル電流 Rated ripple current (mA r.m.s./105°C, 100kHz)	インピーダンス(Ω MAX) Impedance	
				20°C, 100kHz	-10°C, 100kHz
63	15	5×11	55	2.3	9.3
	33	6.3×11	115	1.2	5.0
	56	8×11.5	232	0.63	2.8
	82	8×16	300	0.45	2.1
	82	10×12.5	288	0.43	1.8
	120	8×20	362	0.33	1.6
	120	10×16	357	0.31	1.5
	180	10×20	466	0.21	0.94
	180	12.5×16	466	0.23	1.1
	220	10×23	531	0.20	0.84
	270	10×28	663	0.15	0.71
	270	12.5×20	690	0.16	0.64
	270	16×16	795	0.14	0.66
	330	12.5×25	784	0.12	0.45
	390	18×16	920	0.12	0.50
	470	12.5×30	905	0.10	0.42
	470	16×20	1040	0.091	0.38
	560	12.5×35	1050	0.083	0.35
	560	16×25	1250	0.073	0.27
	680	12.5×40	1180	0.071	0.30
680	18×20	1240	0.080	0.30	
820	16×31.5	1570	0.054	0.20	
820	18×25	1490	0.057	0.21	
1000	16×35.5	1790	0.045	0.17	
1000	18×31.5	1630	0.047	0.17	
1200	16×40	2020	0.040	0.15	
1200	18×35.5	1790	0.040	0.15	
新規採用非推奨品 NOT recommended for new designs					
100	6.8	5×11	55	2.3	9.3
	15	6.3×11	115	1.2	5.0
	27	8×11.5	232	0.63	2.8
	39	8×16	300	0.45	2.1
	47	10×12.5	288	0.43	1.8
	56	8×20	362	0.33	1.6
	68	10×16	357	0.31	1.5
	82	10×20	466	0.21	0.94
	82	12.5×16	466	0.23	1.1
	100	10×23	531	0.20	0.84
	120	10×28	663	0.15	0.71
	120	12.5×20	690	0.16	0.64
	150	16×16	795	0.14	0.66
	180	12.5×25	784	0.12	0.45
	180	18×16	920	0.12	0.50
	220	12.5×30	905	0.10	0.42
	220	16×20	1040	0.091	0.38
	270	12.5×35	1050	0.083	0.35
	270	16×25	1250	0.073	0.27
	330	12.5×40	1180	0.071	0.30
330	18×20	1240	0.080	0.30	
390	16×31.5	1570	0.054	0.20	
390	18×25	1490	0.057	0.21	
470	16×35.5	1790	0.045	0.17	
470	18×31.5	1630	0.047	0.17	
560	16×40	2020	0.040	0.15	
680	18×35.5	1790	0.040	0.15	
820	18×40	2330	0.036	0.13	

Looking for pricing, stock, or lifecycle information?

Click below to explore more details on WIN SOURCE:

-  [View 35YXG470MEFC10X20 on WIN SOURCE](#)
-  [Rubycon Information](#)

Optimize Your Supply Chain with WIN SOURCE Solutions

-  Global Sourcing Solution
-  Obsolete Management
-  Cost Control Management
-  Shortage Management
-  Alternative Solution
-  Excess Inventory Management