



THE DATASHEET OF
0334822102





PRODUCT SPECIFICATION



MX150 DUAL ROW SEALED ASSEMBLY MAT SEAL

REVISION: F10	ECR/ECN INFORMATION: EC No: UAU2016-1442 DATE: 3/28/2016	TITLE: MX150 DUAL ROW SEALED ASSEMBLY MAT SEAL	SHEET No. 1 of 14
DOCUMENT NUMBER: PS-33472-000	CREATED / REVISED BY: Andy Proffitt	CHECKED BY: Katy Boruszewski	APPROVED BY: Vijy Koshy



PRODUCT SPECIFICATION

Table of Contents

1.0	Scope	3
2.0	Product Description.....	3
2.1.	Direct Connect (wire to board application).....	3
2.2.	Inline Applications (wire to wire application)	3
2.3.	Receptacle Assembly.....	4
2.4.	Blade Assembly	4
2.5.	Product Name and Series Number.....	5
3.0	Integral Components and Accessories.....	6
3.1.	Integral Components.....	6
3.1.1.	Receptacle Terminals.....	6
3.1.2.	Blade Terminals	7
3.1.3.	Applicable Wires	7
3.1.3.1.	Wire size	7
3.1.3.2.	ISO Wire.....	7
3.1.3.3.	SAE Wire.....	8
3.1.4.	Terminal Service Tool	8
3.2.	Accessories	8
3.2.1.	Wire Harness Retention Clip - Recommended	8
3.2.2.	Backshell - Recommended.....	8
3.2.3.	Cavity (Seal) Plugs.....	8
4.0	Applicable Documents and Specifications.....	8
5.0	Ratings	9
5.1.	Voltage - Operating.....	9
5.2.	Voltage - Isolation Resistance	9
5.3.	Current Rating.....	9
5.4.	Temperature	9
5.5.	Sealing.....	9
5.6.	Flammability.....	10
5.7.	Dielectric Withstand Strength	10
6.0	Performance	10
6.1.	Electrical Requirements	10
6.2.	Mechanical Requirements.....	11
6.2.1.	Mechanical Requirements Deviations.....	12
6.3.	Environmental Requirements.....	13
7.0	Packaging.....	14
8.0	Gages and Fixtures.....	14
9.0	Other Information.....	14

REVISION: F10	ECR/ECN INFORMATION: EC No: UAU2016-1442 DATE: 3/28/2016	TITLE: MX150 DUAL ROW SEALED ASSEMBLY MAT SEAL	SHEET No. 2 of 14
DOCUMENT NUMBER: PS-33472-000	CREATED / REVISED BY: Andy Proffitt	CHECKED BY: Katy Boruszewski	APPROVED BY: Vijy Koshy



PRODUCT SPECIFICATION

1.0 SCOPE

This product specification covers the 3.50 mm (0.138 inch) centerline (pitch) mat seal dual row MX150 sealed product line connection system. The MX150 connection system uses crimp technology.

2.0 PRODUCT DESCRIPTION

2.1. DIRECT CONNECT (WIRE TO BOARD APPLICATION)

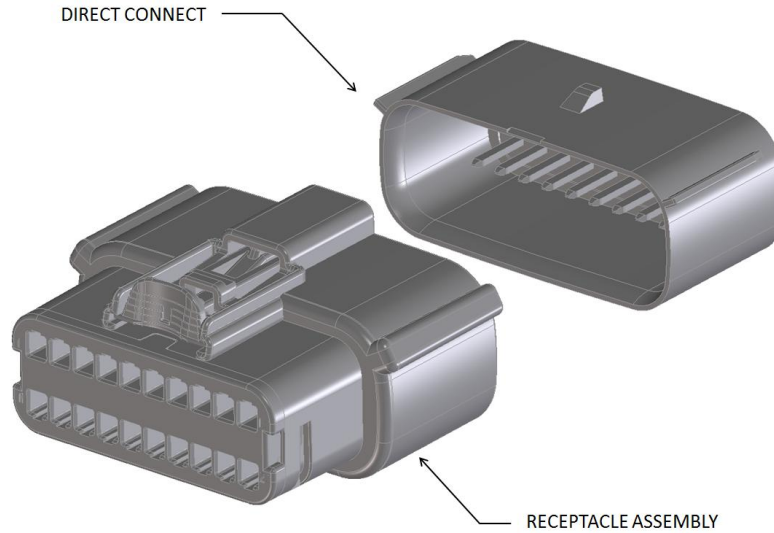

2.2. INLINE APPLICATIONS (WIRE TO WIRE APPLICATION)

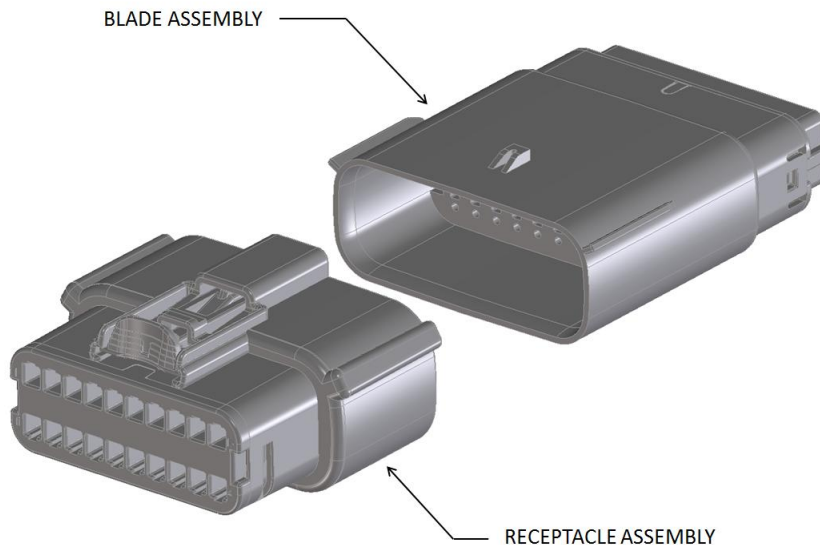

REVISION: F10	ECR/ECN INFORMATION: EC No: UAU2016-1442 DATE: 3/28/2016	TITLE: MX150 DUAL ROW SEALED ASSEMBLY MAT SEAL	SHEET No. 3 of 14
DOCUMENT NUMBER: PS-33472-000	CREATED / REVISED BY: Andy Proffitt	CHECKED BY: Katy Boruszewski	APPROVED BY: Vijy Koshy



PRODUCT SPECIFICATION

2.3. RECEPTACLE ASSEMBLY

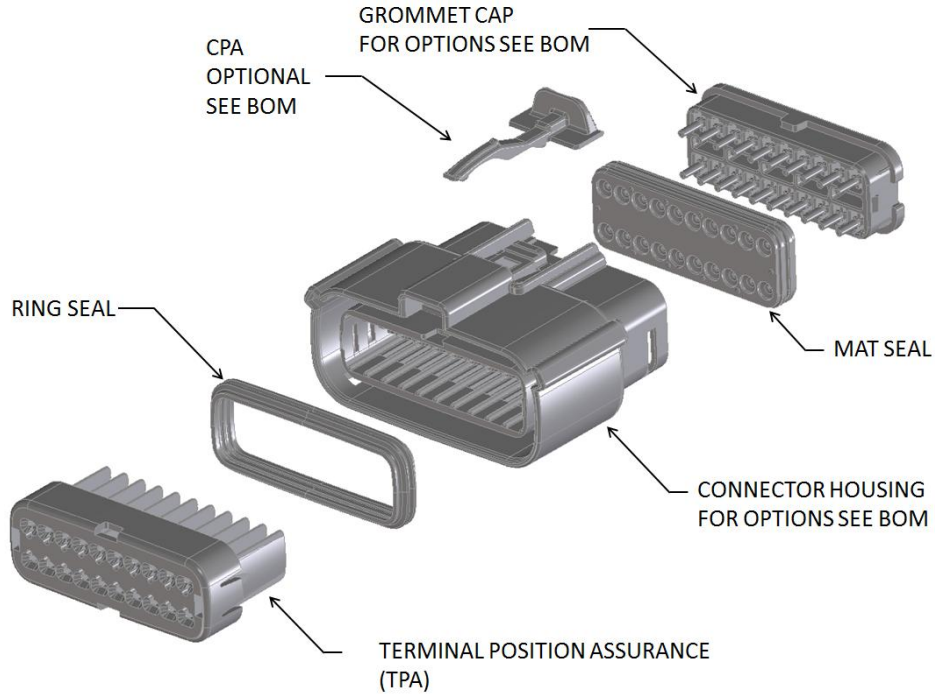

2.4. BLADE ASSEMBLY

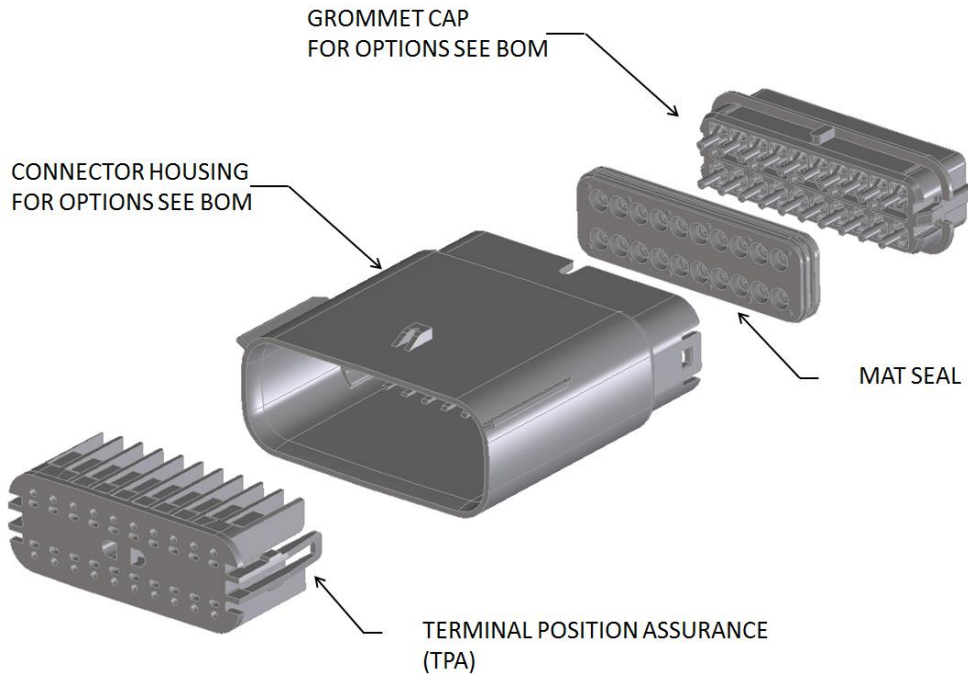

REVISION: F10	ECR/ECN INFORMATION: EC No: UAU2016-1442 DATE: 3/28/2016	TITLE: MX150 DUAL ROW SEALED ASSEMBLY MAT SEAL	SHEET No. 4 of 14
DOCUMENT NUMBER: PS-33472-000	CREATED / REVISED BY: Andy Proffitt	CHECKED BY: Katy Boruszewski	APPROVED BY: Vijy Koshy
TEMPLATE FILENAME: ENGINEERING_SPEC[SIZE_A](V.1).DOC			



PRODUCT SPECIFICATION

2.5. PRODUCT NAME AND SERIES NUMBER

Refer to listed document number for part availability, dimensions, material, marking information, packaging information, interface definition, and configuration options etc.

Product Name	Document Number	Series
MX150 Receptacle 2X2 Sealed Assembly	SD-33472-0001 - Assembly Drawing SD-33472-0002 - Bill of Materials	33472
MX150 Receptacle 2X3 Sealed Assembly		33472 ◇
MX150 Receptacle 2X3 Sealed Assembly with Clipslot		33472 ◇
MX150 Receptacle 2X4 Sealed Assembly		33472
MX150 Receptacle 2X4 Sealed Assembly with Clipslot		33472
MX150 Receptacle 2X6 Sealed Assembly		33472
MX150 Receptacle 2X6 Sealed Assembly with Clipslot		33472
MX150 Receptacle 2X8 Sealed Assembly		33472
MX150 Receptacle 2X10 Sealed Assembly		33472
MX150 Blade 2X2 Sealed Assembly		SD-33482-0001 - Assembly Drawing SD-33482-0002 - Bill of Materials
MX150 Blade 2X3 Sealed Assembly	33482	
MX150 Blade 2X4 Sealed Assembly	33482	
MX150 Blade 2X6 Sealed Assembly	33482	
MX150 Blade 2X8 Sealed Assembly	33482	
MX150 Blade 2X10 Sealed Assembly	33482	

◇ See document numbers listed above for connector assembly part numbers without a mat seal. These part numbers are omitted from PS-33472-000.

REVISION: F10	ECR/ECN INFORMATION: EC No: UAU2016-1442 DATE: 3/28/2016	TITLE: MX150 DUAL ROW SEALED ASSEMBLY MAT SEAL	SHEET No. 5 of 14
DOCUMENT NUMBER: PS-33472-000	CREATED / REVISED BY: Andy Proffitt	CHECKED BY: Katy Boruszewski	APPROVED BY: Vijy Koshy



PRODUCT SPECIFICATION

3.0 INTEGRAL COMPONENTS AND ACCESSORIES

Integral components and accessories are sold separately.

3.1. INTEGRAL COMPONENTS

3.1.1. Receptacle Terminals

For crimping information see the Receptacle Terminal Application Specification listed in section [4.0](#).

Terminal Information	Document Number
MX150 Receptacle, Mat Seal, High Performance, Sn, M3 Grip Code	SD-33012-002
MX150 Receptacle, Mat Seal, High Performance, Au, M3 Grip Code	
MX150 Receptacle, Mat Seal, High Performance, Ag, M3 Grip Code	
MX150 Receptacle, Mat Seal, High Performance, Sn, 22 Grip Code	
MX150 Receptacle, Mat Seal, High Performance, Au, 22 Grip Code	
MX150 Receptacle, Mat Seal, High Performance, Ag, 22 Grip Code	
MX150 Receptacle, Mat Seal, High Performance, Sn, 18 Grip Code	
MX150 Receptacle, Mat Seal, High Performance, Au, 18 Grip Code	
MX150 Receptacle, Mat Seal, High Performance, Ag, 18 Grip Code	
MX150 Receptacle, Mat Seal, High Performance, Sn, 14 Grip Code	
MX150 Receptacle, Mat Seal, High Performance, Au, 14 Grip Code	
MX150 Receptacle, Mat Seal, High Performance, Ag, 14 Grip Code	

REVISION: F10	ECR/ECN INFORMATION: EC No: UAU2016-1442 DATE: 3/28/2016	TITLE: MX150 DUAL ROW SEALED ASSEMBLY MAT SEAL	SHEET No. 6 of 14
DOCUMENT NUMBER: PS-33472-000	CREATED / REVISED BY: Andy Proffitt	CHECKED BY: Katy Boruszewski	APPROVED BY: Vijy Koshy



PRODUCT SPECIFICATION

3.1.2. Blade Terminals

For crimping information see the Blade Terminal Application Specification listed in section [4.0](#).

Terminal Information	Document Number
MX150 Blade Mat Seal, High Performance, Sn, M3 Grip Code	SD-33000-001
MX150 Blade Mat Seal, High Performance, Au, M3 Grip Code	
MX150 Blade Mat Seal, High Performance, Ag, M3 Grip Code	
MX150 Blade Mat Seal, High Performance, Sn, 22 Grip Code	
MX150 Blade Mat Seal, High Performance, Au, 22 Grip Code	
MX150 Blade Mat Seal, High Performance, Ag, 22 Grip Code	
MX150 Blade Mat Seal, High Performance, Sn, 18 Grip Code	
MX150 Blade Mat Seal, High Performance, Au, 18 Grip Code	
MX150 Blade Mat Seal, High Performance, Ag, 18 Grip Code	
MX150 Blade Mat Seal, High Performance, Sn, 14 Grip Code	
MX150 Blade Mat Seal, High Performance, Au, 14 Grip Code	
MX150 Blade Mat Seal, High Performance, Ag, 14 Grip Code	

3.1.3. Applicable Wires

3.1.3.1. Wire size

See section [5.5](#) for wire range recommended per circuit size.

3.1.3.2. ISO Wire

Per the listed wire specifications where the insulation diameter is within 1.20mm to 2.40mm.

- GMW15626 February 2008
- ES-AU5T-1A348-AA Rev D

REVISION: F10	ECR/ECN INFORMATION: EC No: UAU2016-1442 DATE: 3/28/2016	TITLE: MX150 DUAL ROW SEALED ASSEMBLY MAT SEAL	SHEET No. 7 of 14
DOCUMENT NUMBER: PS-33472-000	CREATED / REVISED BY: Andy Proffitt	CHECKED BY: Katy Boruszewski	APPROVED BY: Vijy Koshy



PRODUCT SPECIFICATION

3.1.3.3. SAE Wire

Per the listed wire specifications where the insulation diameter is within 1.50mm to 2.69mm.

- ESB-ML123-A 2003
- SAE J1128 Dec 2005

3.1.4. Terminal Service Tool

See the Connector Application Specification listed in section [4.0](#).

3.2. ACCESSORIES

3.2.1. Wire Harness Retention Clip - Recommended

For further information contact your sales engineer.

3.2.2. Backshell - Recommended

For availability and part numbers see the Assembly Drawing and the Bill of Materials Drawing listed in section [2.5](#).

3.2.3. Cavity (Seal) Plugs

*Seal plugs are not to be used to replace shorting bar terminals.

Information	Description	Document Number
MX150 Cavity Plug, Natural	34345-0001	SD-34345-001

4.0 APPLICABLE DOCUMENTS AND SPECIFICATIONS

Document Title	Document Number
UL File Number	Not Applicable
CSA File Number	Not Applicable
TUV License number	Not Applicable
IMDS Report	Available upon request
Environmental Compliance	Available on molex.com
Connector Application Specification	AS-33472-100
Terminal Product Specification	PS-33012-002
Receptacle Terminal Application Specification	AS-33012-002
Blade Terminal Application Specification	AS-33000-001
Connector Test Summary	TS-33472-0001
PLR Transit Related Product Specification	PS-34646-001
MX150 CPA Installation Guide	AS-33611-001

REVISION: F10	ECR/ECN INFORMATION: EC No: UAU2016-1442 DATE: 3/28/2016	TITLE: MX150 DUAL ROW SEALED ASSEMBLY MAT SEAL	SHEET No. 8 of 14
DOCUMENT NUMBER: PS-33472-000	CREATED / REVISED BY: Andy Proffitt	CHECKED BY: Katy Boruszewski	APPROVED BY: Vijy Koshy



PRODUCT SPECIFICATION

5.0 RATINGS

5.1. VOLTAGE - OPERATING

Operating Voltage: 14 Volts DC Maximum

5.2. VOLTAGE - ISOLATION RESISTANCE

100MΩ Minimum when 500 Volts DC between adjacent terminals and terminals to ground.

5.3. CURRENT RATING

See the Terminal Product Specification listed in section [4.0](#).

5.4. TEMPERATURE

Non-operating: - 40 C° to + 125 C°

Operating: - 40 C° to + 125 C°

5.5. SEALING

- Meets IP67
- Meets IPx9K when the following configuration is used.
 - With CPA
 - With Backshell
 - With Convuluted Conduit

Circuit Size	Part Numbers	Wire Range
2x2	ALL except 33472-04XX 33472-44XX 33482-04XX 33482-44XX	1.20-2.69 mm (0.047–0.106 in)
2X3	ALL ◇	
2X4		
2X6		
2X8		
2X10	33482-21xx – 33482-2999 33472-2xxx	1.40-2.69 mm (0.055–0.106 in)
2X2	33472-04XX 33472-44XX 33482-04XX 33482-44XX	
2X10	33482-20xx	

◇ See document numbers listed in section [2.5](#) for connector assembly part numbers without a mat seal. These part numbers are omitted from PS-33472-000.

REVISION: F10	ECR/ECN INFORMATION: EC No: UAU2016-1442 DATE: 3/28/2016	TITLE: MX150 DUAL ROW SEALED ASSEMBLY MAT SEAL	SHEET No. 9 of 14
DOCUMENT NUMBER: PS-33472-000	CREATED / REVISED BY: Andy Proffitt	CHECKED BY: Katy Boruszewski	APPROVED BY: Vijy Koshy



PRODUCT SPECIFICATION

- Product Performance Is Based On Connector Requirements Per GMW3191 Dec 2007
- Sealing Performance

Circuit Size	Operating Conditions	Additional Required Component
1x2	Sealing Class III Temperature Class III	Convolute CPA

◇ Backshells are one time use only. This condition may cause reduced backshell retention post-test.

5.6. FLAMMABILITY

The burn rate of the plastic material when tested to ISO 3795 shall not exceed 100 mm/min.

5.7. DIELECTRIC WITHSTAND STRENGTH

Connectors withstand 1500V AC between adjacent terminals for 1 minute.

Test performed with the following conditions.

- MX150 2X4 Connector
- JIS C5402 5.1/MIL-STD-202 Method 301
- UL1007 AWG18

6.0 PERFORMANCE

- Additional circuit sizes added to the product family are validated per USCAR-2 Rev. 4 Appendix D.

6.1. ELECTRICAL REQUIREMENTS

ITEM	DESCRIPTION	TEST CONDITION	REQUIREMENT
1	Contact Resistance (Low Level)	Mate connectors: limiting the open circuit voltage of 20 mV and a maximum current of 100 mA.	10 milliohms MAXIMUM
2	Contact Resistance @ Rated Current (Voltage Drop)	Mate connectors: apply a 5 ampere/ 1.0 mm ² current	10 milliohms MAXIMUM
3	Isolation Resistance	Apply a voltage of 500 VDC between adjacent terminals and between terminals to ground.	20 Meg ohms MINIMUM
4	Temperature Rise (via Current Cycling)	Mate terminals: measure the temperature rise at the rated current after: 1008 hours of bench top testing (45 minutes ON and 15 minutes OFF per hour).	Temperature rise over Ambient: +55 C° MAXIMUM

REVISION: F10	ECR/ECN INFORMATION: EC No: UAU2016-1442 DATE: 3/28/2016	TITLE: MX150 DUAL ROW SEALED ASSEMBLY MAT SEAL	SHEET No. 10 of 14
DOCUMENT NUMBER: PS-33472-000	CREATED / REVISED BY: Andy Proffitt	CHECKED BY: Katy Boruszewski	APPROVED BY: Vijy Koshy



PRODUCT SPECIFICATION

6.2. MECHANICAL REQUIREMENTS

ITEM	DESCRIPTION	TEST CONDITION	REQUIREMENT
5	Connector Mate/ Unmate Forces	Mate and unmate connector (male to female) at a rate of 50 ± 6 mm ($2 \pm \frac{1}{4}$ inch) per minute.	75 Newtons MAXIMUM
			Unmate 110 Newtons MINIMUM
6	Terminal Retention Force (in Housing)	Axial pullout force on the terminal in the housing at a rate of 50 ± 6 mm ($2 \pm \frac{1}{4}$ inch) per minute.	90 Newtons MINIMUM
7	Terminal Insertion Force (into Housing)	Apply an axial insertion force on the terminal at a rate of 50 ± 6 mm ($2 \pm \frac{1}{4}$ inch) per minute.	30 Newtons MAXIMUM
8	Connector Audible Feedback	The connector lock must provide audible feedback during connector mating at a rate of 50 ± 6 mm ($2 \pm \frac{1}{4}$ inch) per minute.	7dB over Ambient (C scale)
9	Polarization Feature Effectiveness	Connector must be polarized to prevent mating with similar connectors or incorrect orientation	220 Newtons MINIMUM
10	Terminal Position Assurance (TPA) Insertion Force (into housing)	The force to insert the TPA from the preload (as shipped) position to the final position at a rate of 50 ± 6 mm ($2 \pm \frac{1}{4}$ inch) per minute.	60 Newtons MAXIMUM
11	Terminal Position Assurance (TPA) Extraction Force (in housing)	The force to extract the TPA from the final position to the preload position (as shipped) at a rate of 50 ± 6 mm ($2 \pm \frac{1}{4}$ inch) per minute.	60 Newtons MAXIMUM
12	Connector Position Assurance (CPA) Insertion Force (into housing)	The force to insert the CPA from the preload (as shipped) position to the final position at a rate of 50 ± 6 mm ($2 \pm \frac{1}{4}$ inch) per minute.	40 Newtons MINIMUM (unmated)
			15 Newtons MAXIMUM (fully mated)
13	Connector Position Assurance (CPA) Extraction Force (in housing)	The force to extract the CPA from the final position to the preload position at a rate of 50 ± 6 mm ($2 \pm \frac{1}{4}$ inch) per minute.	60 Newtons MAXIMUM
14	Locator Clip Insertion Force (in housing)	The force to insert the locator clip to the final (as shipped) position at a rate of 50 ± 6 mm ($2 \pm \frac{1}{4}$ inch) per minute.	30 Newtons MAXIMUM
15	Locator Clip Extraction Force (in housing)	The force to extract the locator clip from the final (as shipped) position to out at a rate of 50 ± 6 mm ($2 \pm \frac{1}{4}$ inch) per minute.	110 Newtons MINIMUM

REVISION:	ECR/ECN INFORMATION:	TITLE:	SHEET No.
F10	EC No: UAU2016-1442 DATE: 3/28/2016	MX150 DUAL ROW SEALED ASSEMBLY MAT SEAL	11 of 14
DOCUMENT NUMBER:	CREATED / REVISED BY:	CHECKED BY:	APPROVED BY:
PS-33472-000	Andy Proffitt	Katy Boruszewski	Vijy Koshy



PRODUCT SPECIFICATION

6.2.1. Mechanical Requirements Deviations

ITEM	DESCRIPTION	TEST CONDITION	CKT	BLADE/ RCPT	REQUIREMENT
7	Terminal Insertion Force for Wire Diameter above 2.5mm not exceeding 2.69mm (into Housing)	Apply an axial insertion force on the terminal at a rate of 50 ± 6 mm ($2 \pm \frac{1}{4}$ inch) per minute.	ALL	BLADE	45 Newtons MAXIMUM
				RCPT	40 Newtons MAXIMUM
10	Terminal Position Assurance (TPA) Insertion Force (into housing)	The force to insert the TPA from the preload (as shipped) position to the final position at a rate of 50 ± 6 mm ($2 \pm \frac{1}{4}$ inch) per minute.	2X2	RCPT	90 Newtons MAXIMUM
11	Terminal Position Assurance (TPA) Extraction Force (in housing)	The force to extract the TPA from the final position to the preload position (as shipped) at a rate of 50 ± 6 mm ($2 \pm \frac{1}{4}$ inch) per minute.	2X2	RCPT	90 Newtons MAXIMUM
			2X3		130 Newtons MAXIMUM
			2x4		130 Newtons MAXIMUM
			2X10	BLADE	75 Newtons MAXIMUM
				RCPT	130 Newtons MAXIMUM
13	Connector Position Assurance (CPA) Extraction Force (in housing)	The force to extract the CPA from the final position to the preload position at a rate of 50 ± 6 mm ($2 \pm \frac{1}{4}$ inch) per minute.	ALL	RCPT	40 Newtons MAXIMUM
					3 Newtons MINIMUM

REVISION: F10	ECR/ECN INFORMATION: EC No: UAU2016-1442 DATE: 3/28/2016	TITLE: MX150 DUAL ROW SEALED ASSEMBLY MAT SEAL	SHEET No. 12 of 14
DOCUMENT NUMBER: PS-33472-000	CREATED / REVISED BY: Andy Proffitt	CHECKED BY: Katy Boruszewski	APPROVED BY: Vijy Koshy



PRODUCT SPECIFICATION

6.3. ENVIRONMENTAL REQUIREMENTS

ITEM	DESCRIPTION	TEST CONDITION	REQUIREMENT						
16	Field Correlated Life Test (FCLT)	Mate connectors up to 1 cycle and expose to environment per SAE/USCAR-20.	20 milliohms MAXIMUM						
17	Durability	Mate connectors up to 10 cycles prior to environmental tests.	10 milliohms MAXIMUM & Discontinuity < 1 microsecond						
18	Thermal Shock (Electrical)	Mate connectors per durability; expose to 100 cycles of: <table border="1" style="margin-left: 20px;"> <tr> <td>Temperature C°</td> <td>Duration (Minutes)</td> </tr> <tr> <td>-40 +0/-3</td> <td>30</td> </tr> <tr> <td>+125 +3/-0</td> <td>30</td> </tr> </table>	Temperature C°	Duration (Minutes)	-40 +0/-3	30	+125 +3/-0	30	10 milliohms MAXIMUM & Discontinuity < 1 microsecond
Temperature C°	Duration (Minutes)								
-40 +0/-3	30								
+125 +3/-0	30								
19	High Temperature Exposure (Sealing)	Mate connectors per durability and expose to 1008 hours at 125 ± 2°C	28 kPa for 15 seconds MINIMUM pressure/vacuum & Submersion for 30 minutes & Isolation Resistance of 20 Meg ohms @ 500 VDC MINIMUM						
20	Temperature/ Humidity (Sealing)	Mate connectors per durability and expose connector system to forty 8-hour cycles of combined heating and humidity exposure -40 °C and 125 °C at 0% to 90% RH	28 kPa for 15 seconds MINIMUM pressure/vacuum & Submersion for 30 minutes & Isolation Resistance of 20 Meg ohms @ 500 VDC MINIMUM						
21	Fluid Resistance (Sealing)	Submerge connector assemblies in the following fluids: gasoline, *diesel fuel, engine oil, ethanol, power steering fluid, automatic transmission fluid, engine coolant, and brake fluid.	Submersion for 30 minutes & Isolation Resistance of 20 Meg ohms @ 500 VDC MINIMUM						
22	Vibration/ Mechanical Shock (Electrical)	Mate connectors per durability. Connector assembly shall be vibrated for (8 hours / axes @ 12.1 Grms, 10 shocks @ 35 Gs / axes) Coupled to engine.	10 milliohms MAXIMUM & Discontinuity < 1 microsecond						

* Silicone seals swell in the presence of gasoline and diesel fuel. This condition may cause excessive connector mate/unmate forces and/or reduce the Grommet Cap retention.

REVISION: F10	ECR/ECN INFORMATION: EC No: UAU2016-1442 DATE: 3/28/2016	TITLE: MX150 DUAL ROW SEALED ASSEMBLY MAT SEAL	SHEET No. 13 of 14
DOCUMENT NUMBER: PS-33472-000	CREATED / REVISED BY: Andy Proffitt	CHECKED BY: Katy Boruszewski	APPROVED BY: Vijy Koshy



PRODUCT SPECIFICATION

7.0 PACKAGING

- Molex packaging drawing numbers are located on the Assembly Drawing listed in section [2.5](#).
- Parts should be packaged to protect against damage during handling, transit and storage.

8.0 GAGES AND FIXTURES

All applicable gages and fixtures are referenced in the appropriate control plans.

9.0 OTHER INFORMATION

- Products confirm to USCAR-2 class III environment.
- ♦ See document numbers listed in section [2.5](#) for connector assembly part numbers without a mat seal. These part numbers are omitted from PS-33472-000.
- To add new knock out patterns contact your sales engineer.

MOLEX REPRESENTS AND WARRANTS TO BUYER FOR A PERIOD OF ONE (1) YEAR FROM THE DATE OF DELIVERY OF THE PRODUCTS TO BUYER THAT

- 1) THE PRODUCTS SHALL CONFORM TO THE MOLEX SPECIFICATIONS FOR THE PRODUCTS IN FORCE AT THE DATE OF DELIVERY OF THE PRODUCTS TO BUYER, AND
- 2) THE PRODUCTS SHALL BE OF FREE FROM MATERIAL DEFECTS IN MATERIALS AND MANUFACTURING.

EXCEPT AS EXPRESSLY PROVIDED ABOVE, MOLEX MAKES NO WARRANTY, EXPRESS OR IMPLIED, REGARDING THE PRODUCTS. ALL IMPLIED WARRANTIES, INCLUDING, BUT NOT LIMITED TO, THE IMPLIED WARRANTIES OF FITNESS FOR A PARTICULAR PURPOSE, ARE HEREBY DISCLAIMED. IN ADDITION, MOLEX EXPRESSLY DISCLAIMS ANY WARRANTY OBLIGATIONS IN THOSE INSTANCES WHERE THE FAILURES RESULTED FROM THE MODIFICATION OF THE PRODUCTS BY BUYER OR ITS CUSTOMERS, IMPROPER HANDLING, USE OR INSTALLATION OF THE PRODUCTS BY BUYER OR ITS CUSTOMERS, OR ANY OTHER CAUSE BEYOND THE CONTROL OF MOLEX.

REVISION: F10	ECR/ECN INFORMATION: EC No: UAU2016-1442 DATE: 3/28/2016	TITLE: MX150 DUAL ROW SEALED ASSEMBLY MAT SEAL	SHEET No. 14 of 14
DOCUMENT NUMBER: PS-33472-000	CREATED / REVISED BY: Andy Proffitt	CHECKED BY: Katy Boruszewski	APPROVED BY: Vijy Koshy

Looking for pricing, stock, or lifecycle information?

Click below to explore more details on WIN SOURCE:

 [View 0334822102 on WIN SOURCE](#)

 [Molex, LLC Information](#)

Optimize Your Supply Chain with WIN SOURCE Solutions

-  Global Sourcing Solution
-  Obsolete Management
-  Cost Control Management
-  Shortage Management
-  Alternative Solution
-  Excess Inventory Management