





# TAI-SAW TECHNOLOGY CO., LTD.

No. 3, Industrial 2nd Rd., Ping-Chen Industrial District,  
Taoyuan, 324, Taiwan, R.O.C.

TEL: 886-3-4690038 FAX: 886-3-4697532

E-mail: [ttsales@mail.taisaw.com](mailto:ttsales@mail.taisaw.com) Web: [www.taisaw.com](http://www.taisaw.com)

## Product Specifications Approval Sheet

Product Description: SAW Filter 1582.4 MHz (BW 46.61MHz) SMD 1.4X1.1 mm

TST Part No.: TA2396A (This part is compliant with AEC-Q200)

Customer Part No.: \_\_\_\_\_

Customer signature required
Company: _____
Division: _____
Approved by : _____
Date: _____

Checked by: \_\_\_\_\_ Michael Yang *Michael*

Approval by: \_\_\_\_\_ Andy Yu *Andy Yu*

Date: \_\_\_\_\_ 2018/08/07

1. Customer signed back is required before TST can proceed with sample build and receive orders.
2. Orders received without customer signed back will be regarded as agreement on the specifications.
3. Any specifications changes must be approved upon by both parties and a new revision of specifications shall be released to reflect the changes.



# TAI-SAW TECHNOLOGY CO., LTD.

No. 3, Industrial 2nd Rd., Ping-Chen Industrial District,  
Taoyuan, 324, Taiwan, R.O.C.

TEL: 886-3-4690038 FAX: 886-3-4697532

E-mail: [tstsales@mail.taisaw.com](mailto:tstsales@mail.taisaw.com) Web: [www.taisaw.com](http://www.taisaw.com)

## SAW Filter 1582.4MHz

MODEL NO.:TA2396A

REV. NO.:2.0

### A. MAXIMUM RATING:

1. Input Power Level: 15 dBm
2. Input Power Level at 915MHz: 23 dBm
3. DC Voltage : 3V
4. Operating Temperature: -40 °C to +125 °C
5. Storage Temperature: -40 °C to +125 °C
6. Moisture Sensitivity Level: Level 3(MSL3)

RoHS Compliant  
Lead free  
Lead-free soldering

Electrostatic Sensitive Device (ESD)

### B. ELECTRICAL CHARACTERISTICS:

Terminating source impedance (single) :  $Z_s = 50 \Omega$

Terminating load impedance (single) :  $Z_L = 50 \Omega$

Item	Unit	min	Type.	max
<b>Center Frequency</b> <b>Fc</b>	MHz	-	1582.4	-
<b>Insertion Loss</b> (1559.05~1563.15 MHz) <b>IL</b>	dB		1.8	2.0
<b>Insertion Loss</b> (1573.37~1577.47 MHz) <b>IL</b>	dB		1.0	2.0
<b>Insertion Loss</b> (1574.42~1576.42 MHz) <b>IL</b>	dB		1.0	1.4
<b>Insertion Loss</b> (1597.78~1605.66 MHz) <b>IL</b>	dB		1.6	2.2
<b>VSWR</b> (1559.05~1563.15 MHz)			1.6	2.1
<b>VSWR</b> (1574.42~1576.42 MHz)			1.3	2.1
<b>VSWR</b> (1597.78~1605.66 MHz)			1.6	2.1
<b>Variation of group delay</b> (1597.78~1605.66 MHz)	ns		4	14 <sup>1)</sup>
<b>Attenuation</b>				
50 ~ 824 MHz	dB	36	41	
824 ~ 925 MHz	dB	35	40	
1427 ~ 1453 MHz	dB	38	43	
1710 ~ 1785 MHz	dB	27	32	
1850 ~ 1910 MHz	dB	33	38	
1920 ~ 1980 MHz	dB	33	38	
2400 ~ 2500 MHz	dB	35	40	
2500 ~ 2570 MHz	dB	33	38	
2600 ~ 3000 MHz	dB	29	34	

Temperature coefficient	ppm/°C	-36
Package size	mm	1411

1) Averaged over 2 MHz

C.OUTLINE DRAWING:

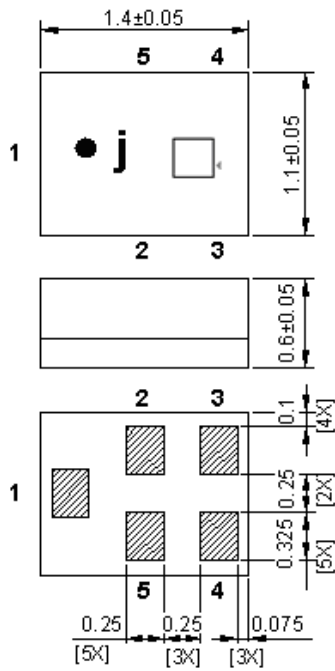

All tolerances are  $\pm 0.05$  mm unless otherwise specified  
 Coplanarity : 0.1 mm max.  
 1 to 5 : Pin No.  
 Unit : mm

Pin No.Ⓟ	SymbolⓅ	FunctionⓅ
1Ⓟ	INⓅ	InputⓅ
2Ⓟ	GNDⓅ	GroundⓅ
3Ⓟ	GNDⓅ	GroundⓅ
4Ⓟ	OUTⓅ	OutputⓅ
5Ⓟ	GNDⓅ	GroundⓅ

□ : Year/Month Code (Follow the table)

YEAR/Month	1	2	3	4	5	6	7	8	9	10	11	12
2013	A	B	C	D	E	F	G	H	J	K	L	M
2014	N	P	Q	R	S	T	U	V	W	X	Y	Z
2015	a	b	c	d	e	f	g	h	j	k	l	m
2016	n	p	q	r	s	t	u	v	w	x	y	z
2017	<u>A</u>	<u>B</u>	<u>C</u>	<u>D</u>	<u>E</u>	<u>F</u>	<u>G</u>	<u>H</u>	<u>J</u>	<u>K</u>	<u>L</u>	<u>M</u>
2018	<u>N</u>	<u>P</u>	<u>Q</u>	<u>R</u>	<u>S</u>	<u>T</u>	<u>U</u>	<u>V</u>	<u>W</u>	<u>X</u>	<u>Y</u>	<u>Z</u>
2019	<u>a</u>	<u>b</u>	<u>c</u>	<u>d</u>	<u>e</u>	<u>f</u>	<u>g</u>	<u>h</u>	<u>i</u>	<u>k</u>	<u>l</u>	<u>m</u>
2020	<u>n</u>	<u>p</u>	<u>q</u>	<u>r</u>	<u>s</u>	<u>t</u>	<u>u</u>	<u>v</u>	<u>w</u>	<u>x</u>	<u>y</u>	<u>z</u>

D. MEASUREMENT CIRCUIT:

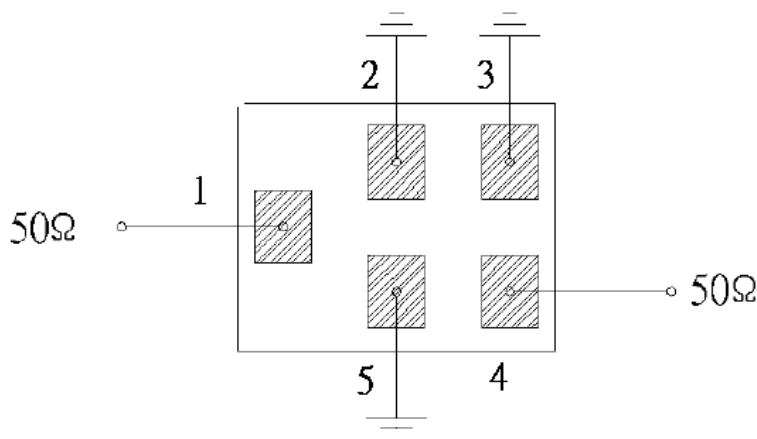

**E. Frequency Characteristics:  
S21 response: (span 500MHz)**

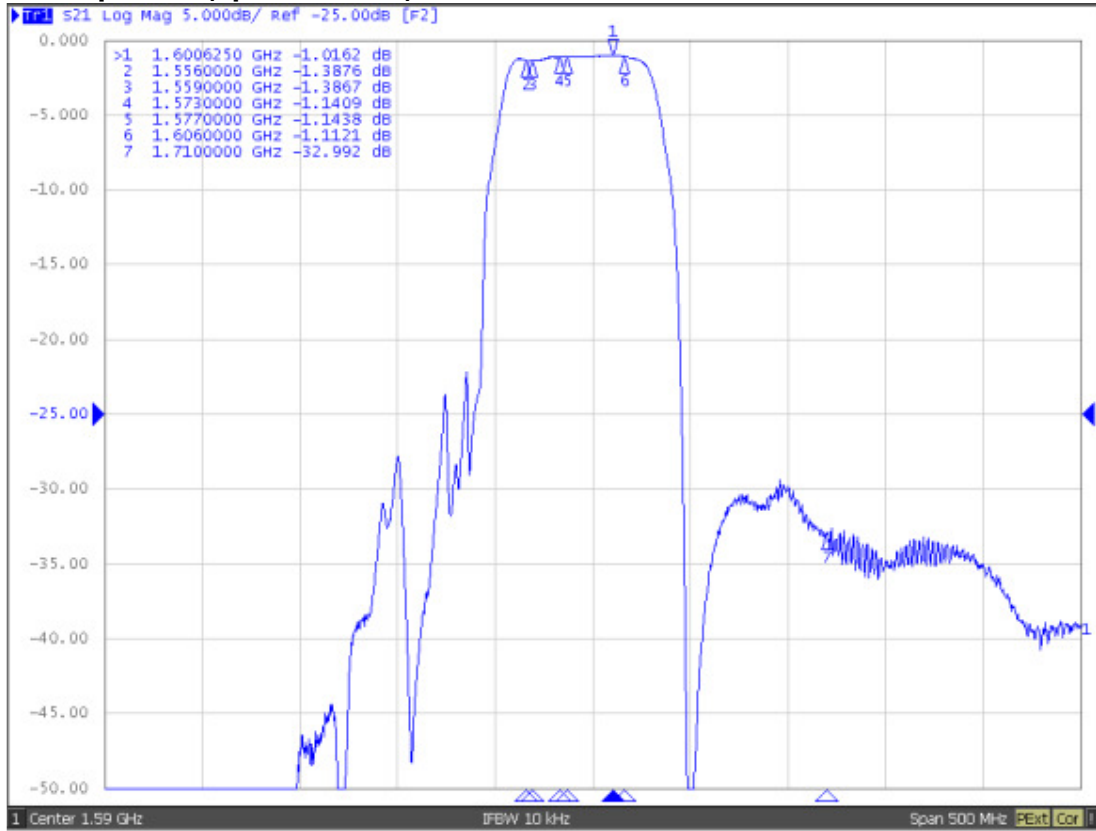

**S21 response: (span 120MHz)**

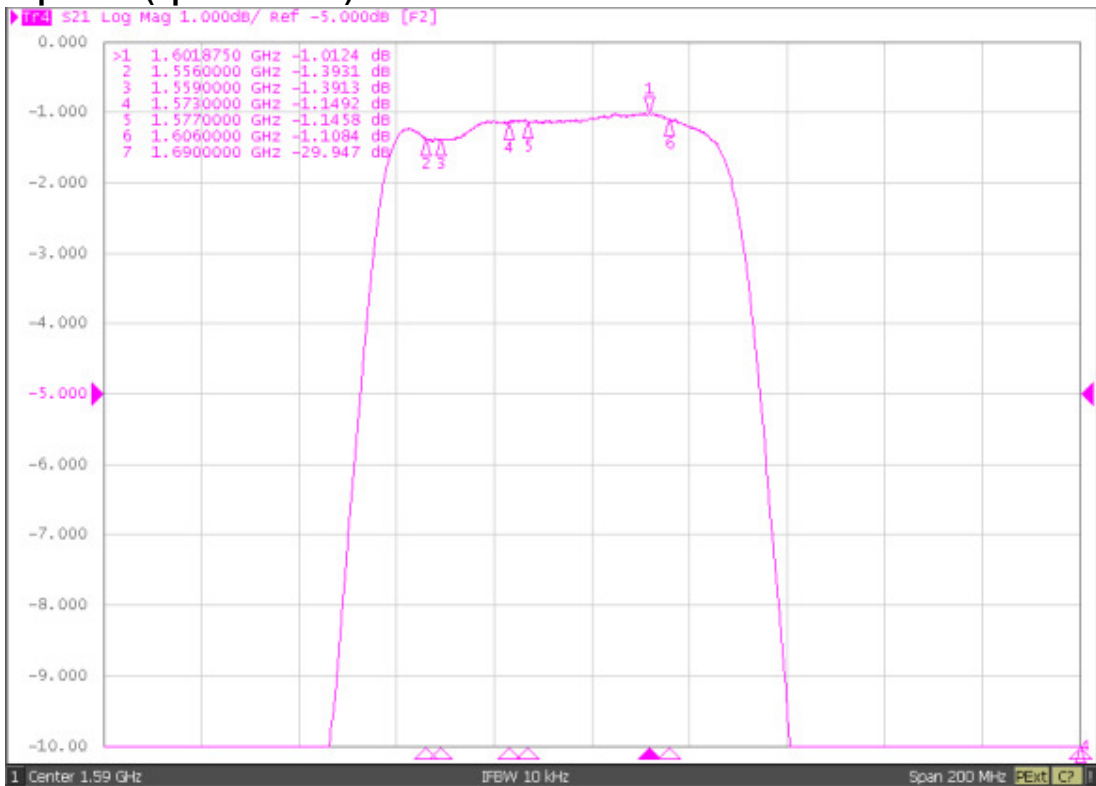

### S11/S22 response :

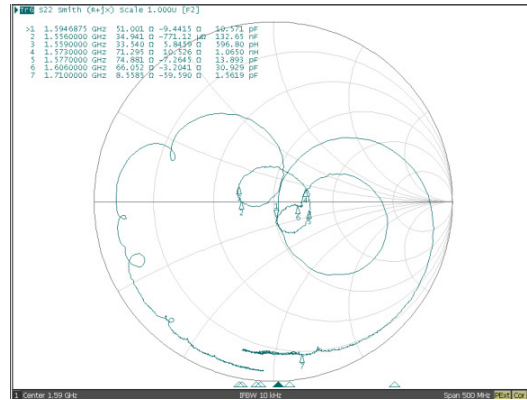
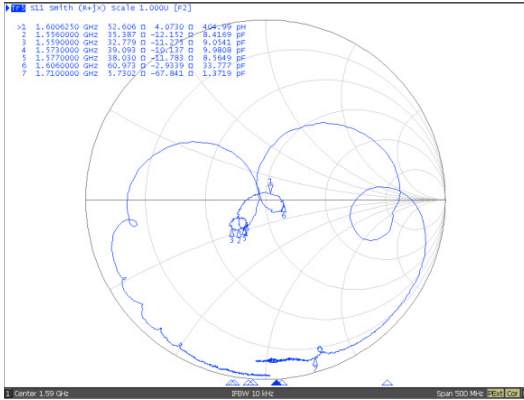

### S21 response: (span 4.5GHz)

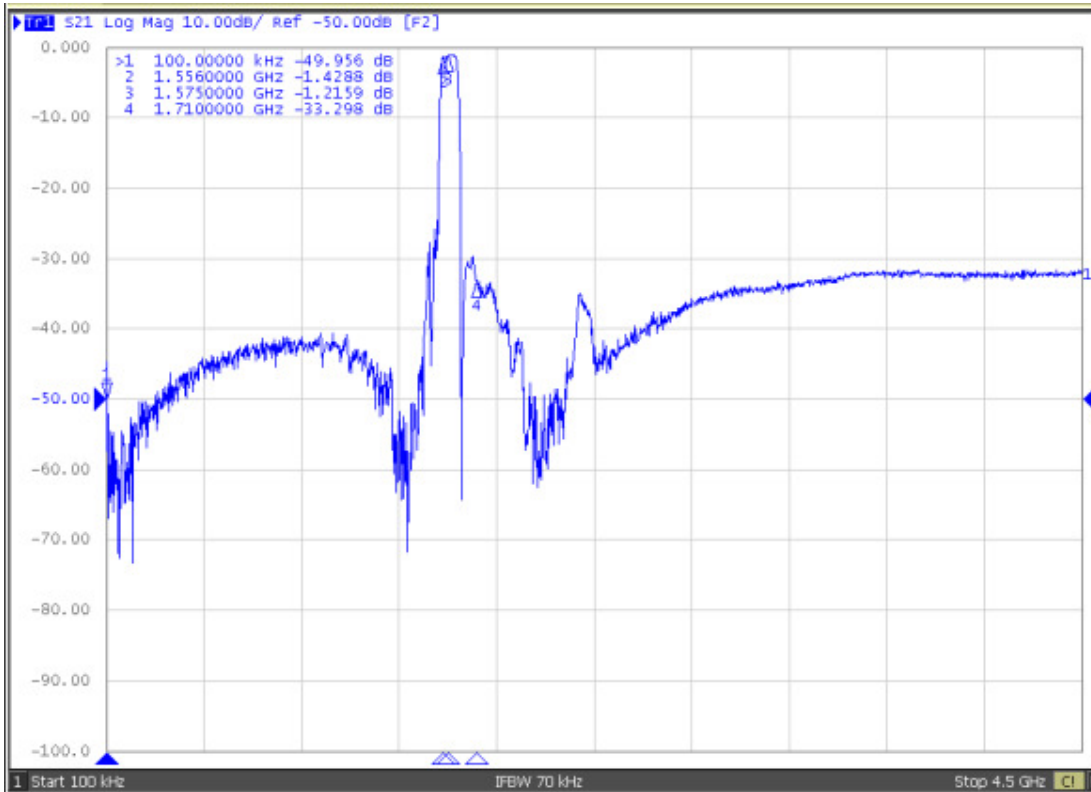

**F. PCB Footprint:**

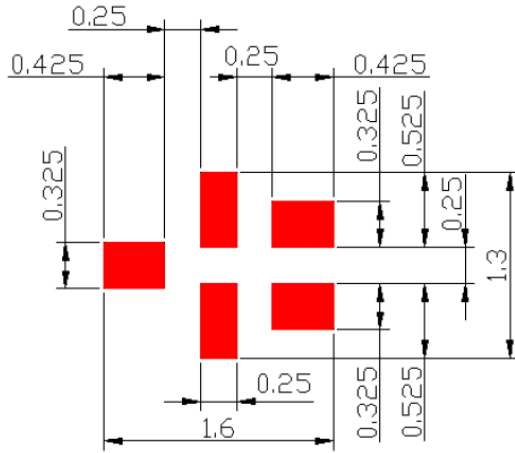

: Land Pattern

**G. PACKING:**

**1. REEL DIMENSION**

**(Please refer to FR-75D10 for packing quantity)**

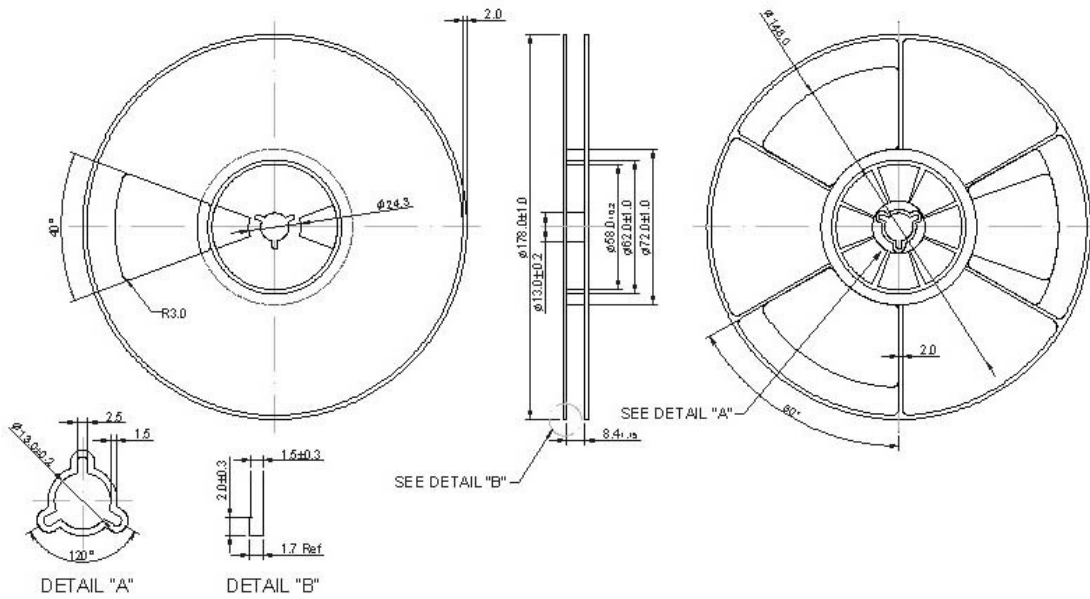



## Looking for pricing, stock, or lifecycle information?

Click below to explore more details on WIN SOURCE:

 [View TA2396A on WIN SOURCE](#)

 [TST - Tamsan Information](#)

## Optimize Your Supply Chain with WIN SOURCE Solutions

-  Global Sourcing Solution
-  Obsolete Management
-  Cost Control Management
-  Shortage Management
-  Alternative Solution
-  Excess Inventory Management