



**THE DATASHEET OF
BGS12WN6E6327XTSA1**



BGS12WN6

0.05–9 GHz SPDT switch with fast switching speed

Features

- Frequency range from 0.05 to 9 GHz
- Small size $0.7 \times 1.1 \text{ mm}^2$ and ultra-low profile of 0.375 mm height max
- Fast switching speed
- Low insertion loss and high port to port isolation up to 9 GHz
- RF input power up to 30 dBm power
- Low current consumption
- No DC blocking capacitors required if no DC applied on RF lines
- RoHS and WEEE compliant package

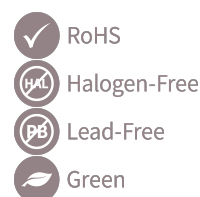

Potential applications

Antenna selection and switching of transmit signals (Tx/Rx) in

- IEEE 802.11a/b/g/n/ac/ax WLAN Networks
- Bluetooth (up to 6.0)
- Ultra-Wide-Band (UWB IEEE 802.15.4)
- Cellular applications (up to 6G)

Product validation

Qualified for industrial applications according to the relevant tests of JEDEC47/20/22.

Description

The BGS12WN6 is a broadband SPDT RF switch suitable for various wireless systems, including WiFi \BT, UWB, and cellular. Its high linearity performance and low insertion loss make it an ideal choice for switching transmit signals, e.g., as Tx \Rx switch or as antenna diversity switch. The integrated on-chip CMOS logic allows direct connection to a digital control pin, eliminating the need for extra interface circuitry, thereby simplifying system design, and reducing component count. The isolated port is a reflective short. The device's flexible voltage supply and control enable easy adaptation to diverse applications and use cases. The BGS12WN6 is fabricated using Infineon's proprietary RF CMOS technology. Housed in a miniature package, this device is particularly well-suited for applications where PCB space is critical, allowing for optimal utilization of available board real estate.

Type	Marking	Package	Ordering Information
BGS12WN6	K	PG-TSNP-6-10 PG-TSNP-6-2	BGS 12WN6 E6327 BGS 12WN6 E6329

BGS12WN6

0.05–9 GHz SPDT switch with fast switching speed



Block diagram

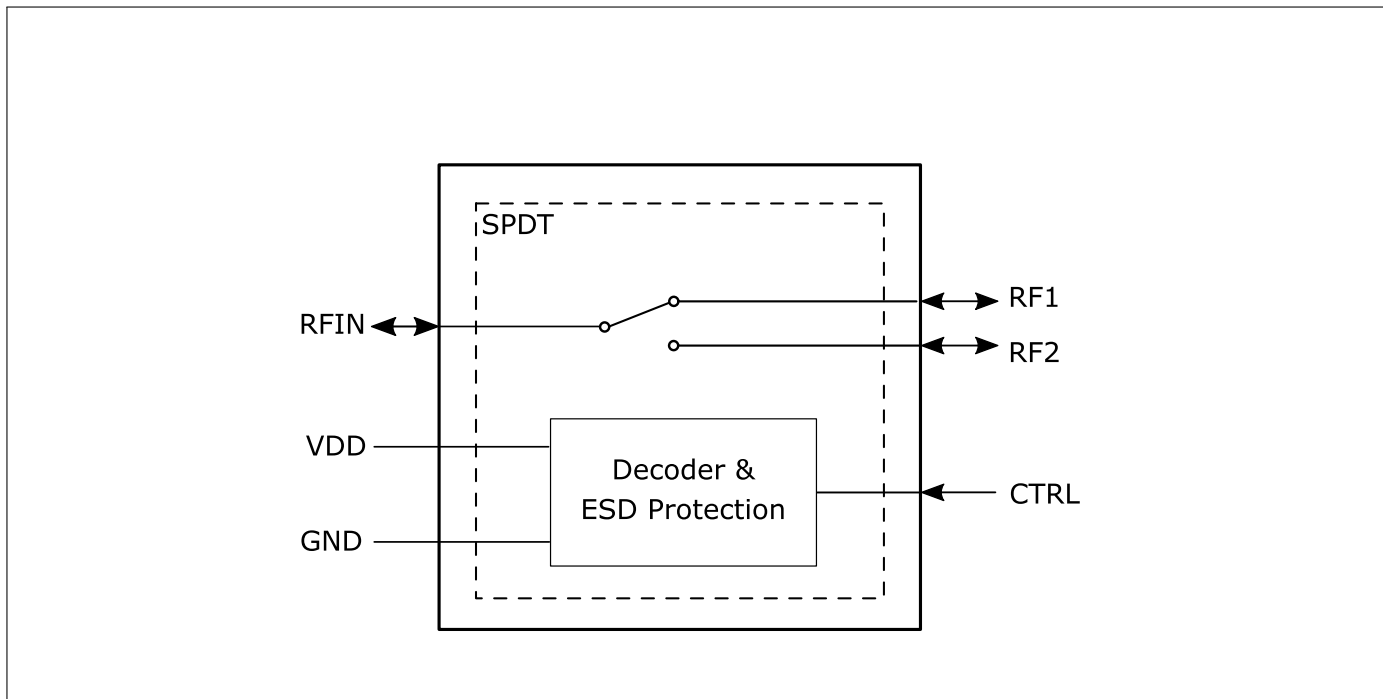

BGS12WN6

0.05–9 GHz SPDT switch with fast switching speed

Table of contents

Table of contents

1	Absolute maximum ratings	2
2	Operation ranges	3
3	RF characteristics	4
4	Application information	9
5	Package information	10

BGS12WN6

0.05–9 GHz SPDT switch with fast switching speed

Absolute maximum ratings

1 Absolute maximum ratings

Table 1: Absolute maximum ratings at $T_A = 25\text{ °C}$, unless otherwise specified

Parameter	Symbol	Values			Unit	Note / Test condition
		Min.	Typ.	Max.		
Frequency range ¹⁾	f	0.05	–	9	GHz	–
Supply voltage	V_{DD}	0	–	4.2	V	–
Storage temperature range	T_{STG}	–55	–	150	°C	–
RF input power at all RF ports	$P_{RF,max}$	–	–	30	dBm	CW / VSWR 1:1 / $Z_0 = 50\ \Omega$
ESD capability, CDM ²⁾	$V_{ESD,CDM}$	–1	–	+1	kV	–
ESD capability, HBM ³⁾	$V_{ESD,HBM}$	–1	–	+1	kV	–
ESD capability RF ports ⁴⁾	$V_{ESD,RF}$	–8	–	+8	kV	Each single RF-in/out port versus GND, with 27 nH shunt inductor
		–6	–	+6	kV	Each single RF-in/out port versus GND, with 56 nH shunt inductor
Junction temperature	T_j	–	–	125	°C	–
Thermal resistance junction - soldering point	R_{thJS}	–	–	70	K/W	–
Maximum DC-voltage on RF ports and RF-Ground	V_{RFDC}	0	–	0	V	No DC voltages allowed on RF-Ports

¹⁾There is also a DC connection between switched paths. The DC voltage at RF ports V_{RFDC} has to be 0 V.

²⁾Field-Induced Charged-Device Model ANSI/ESDA/JEDEC JS-002. Simulates charging/discharging events that occur in production equipment and processes. Potential for CDM ESD events occurs whenever there is metal-to-metal contact in manufacturing.

³⁾Human Body Model ANSI/ESDA/JEDEC JS-001 ($R = 1.5\text{ k}\Omega$, $C = 100\text{ pF}$).

⁴⁾IEC 61000-4-2 ($R = 330\ \Omega$, $C = 150\text{ pF}$), contact discharge.

Attention: Stresses above the max. values listed here may cause permanent damage to the device. Maximum ratings are absolute ratings; exceeding only one of these values may cause irreversible damage to the integrated circuit. Exposure to conditions at or below absolute maximum rating but above the specified maximum operation conditions may affect device reliability and life time. Functionality of the device might not be given under these conditions.

BGS12WN6

0.05–9 GHz SPDT switch with fast switching speed

Operation ranges

2 Operation ranges

Table 2: Operation ranges, at $T_A = -40\text{ °C} \dots 85\text{ °C}$, $V_{DD} = 1.65\text{ V} \dots 3.6\text{ V}$, unless otherwise specified

Parameter	Symbol	Values			Unit	Note / Test condition
		Min.	Typ.	Max.		
Ambient temperature	T_A	-40	25	85	°C	-
Supply voltage	V_{DD}	1.65	1.8	3.6	V	-
Control voltage Low	$V_{Ctrl,L}$	-0.3	-	0.45	V	-
Control voltage High	$V_{Ctrl,H}$	1.0	-	V_{DD}	V	-
Supply current	I_{DD}	-	63	100	μA	$T_A = 25\text{ °C}$, $V_{DD} = 1.8\text{ V}$, $V_{Ctrl} = -0.3\text{ V} \dots 0.45\text{ V}$ 1.35 V...1.8 V
		-	63	120	μA	$V_{Ctrl} = -0.3\text{ V} \dots 0.45\text{ V}$ 1.35 V... V_{DD}
		-	63	125	μA	$V_{Ctrl} = 1.0\text{ V} \dots 1.35\text{ V}$
Control current	I_{Ctrl}	-	2	10	nA	-

Table 3: RF Input power, at $T_A = -40\text{ °C} \dots 85\text{ °C}$, $V_{DD} = 1.65\text{ V} \dots 3.6\text{ V}$, VSWR 1:1 / $Z_0 = 50\ \Omega$, unless otherwise specified

Parameter	Symbol	Values			Unit	Note / Test condition
		Min.	Typ.	Max.		
RF input power at all RF ports	P_{RF}	-	-	26	dBm	CW
				30	dBm	$T_A = 25\text{ °C}$, duty cycle $\leq 1\%$
				29	dBm	$T_A = 85\text{ °C}$, duty cycle $\leq 1\%$

RF characteristics

3 RF characteristics

Table 4: RF characteristics at $T_A = -40\text{ °C} \dots 85\text{ °C}$, $P_{RF} = 0\text{ dBm}$, $V_{DD} = 1.65\text{ V} \dots 3.6\text{ V}$, unless otherwise specified

Parameter	Symbol	Values			Unit	Note / Test condition
		Min.	Typ.	Max.		
Insertion loss¹⁾ at $T_A = 25\text{ °C}$, $V_{DD} = 1.8\text{ V}$						
All RF ports	<i>IL</i>	–	0.15	0.20	dB	50–698 MHz
		–	0.16	0.21	dB	699–960 MHz
		–	0.19	0.26	dB	1200–2170 MHz
		–	0.22	0.29	dB	2170–2690 MHz
		–	0.30	0.42	dB	3300–4200 MHz
		–	0.38	0.52	dB	4400–5000 MHz
		–	0.46	0.68	dB	5150–5925 MHz
		–	0.62	0.93	dB	5925–7125 MHz
		–	0.79	1.15	dB	7125–7737 MHz
		–	0.91	1.34	dB	7737–8237 MHz
–	1.12	1.85	dB	8237–9000 MHz		
Insertion loss¹⁾						
All RF ports	<i>IL</i>	–	0.15	0.25	dB	50–698 MHz
		–	0.16	0.25	dB	699–960 MHz
		–	0.19	0.31	dB	1200–2170 MHz
		–	0.22	0.34	dB	2170–2690 MHz
		–	0.30	0.48	dB	3300–4200 MHz
		–	0.38	0.58	dB	4400–5000 MHz
		–	0.46	0.75	dB	5150–5925 MHz
		–	0.62	1.00	dB	5925–7125 MHz
		–	0.79	1.25	dB	7125–7737 MHz
		–	0.91	1.45	dB	7737–8237 MHz
–	1.12	2.00	dB	8237–9000 MHz		
Return loss¹⁾						
All RF ports	<i>RL</i>	28	33	–	dB	50–698 MHz
		26	29	–	dB	699–960 MHz
		20	23	–	dB	1200–2170 MHz
		18	20	–	dB	2170–2690 MHz
		14	16	–	dB	3300–4200 MHz
		13	14	–	dB	4400–5000 MHz
		11	13	–	dB	5150–5925 MHz
		9.5	11	–	dB	5925–7125 MHz
		9	10	–	dB	7125–7737 MHz
		8	9	–	dB	7737–8237 MHz
7	8	–	dB	8237–9000 MHz		

¹⁾ Measured on prober station to exclude board effects, without any matching components.

BGS12WN6

0.05–9 GHz SPDT switch with fast switching speed



RF characteristics

Table 5: RF characteristics at $T_A = -40\text{ }^{\circ}\text{C} \dots 85\text{ }^{\circ}\text{C}$, $P_{RF} = 0\text{ dBm}$, $V_{DD} = 1.65\text{ V} \dots 3.6\text{ V}$, unless otherwise specified

Parameter	Symbol	Values			Unit	Note / Test condition
		Min.	Typ.	Max.		
Isolation¹⁾						
RFIN to RF1 port	$ISO_{RFIN-RF1}$	43	53	–	dB	50–698 MHz
		40	46	–	dB	699–960 MHz
		33	39	–	dB	1200–2170 MHz
		31	37	–	dB	2170–2690 MHz
		26	33	–	dB	3300–4200 MHz
		24	30	–	dB	4400–5000 MHz
		21	28	–	dB	5150–5925 MHz
		20	25	–	dB	5925–7125 MHz
		19	24	–	dB	7125–7737 MHz
		18	23	–	dB	7737–8237 MHz
RFIN to RF2 port	$ISO_{RFIN-RF2}$	43	52	–	dB	50–698 MHz
		40	45	–	dB	699–960 MHz
		33	39	–	dB	1200–2170 MHz
		31	36	–	dB	2170–2690 MHz
		26	31	–	dB	3300–4200 MHz
		24	29	–	dB	4400–5000 MHz
		21	26	–	dB	5150–5925 MHz
		20	25	–	dB	5925–7125 MHz
		19	24	–	dB	7125–7737 MHz
		18	23	–	dB	7737–8237 MHz
RF1 to RF2 port / RF2 to RF1 port	$ISO_{Port-Port}$	53	63	–	dB	50–698 MHz
		50	56	–	dB	699–960 MHz
		41	49	–	dB	1200–2170 MHz
		39	45	–	dB	2170–2690 MHz
		34	40	–	dB	3300–4200 MHz
		30	36	–	dB	4400–5000 MHz
		25	33	–	dB	5150–5925 MHz
		23	31	–	dB	5925–7125 MHz
		21	29	–	dB	7125–7737 MHz
		19	28	–	dB	7737–8237 MHz
		17	27	–	dB	8237–9000 MHz

¹⁾ Measured on application board, without any matching components.

BGS12WN6

0.05–9 GHz SPDT switch with fast switching speed



RF characteristics

Table 6: WIFI RF characteristics at $T_A = 25\text{ °C}$, $V_{DD} = 1.65\text{ V} \dots 3.6\text{ V}$, unless otherwise specified

Parameter	Symbol	Values			Unit	Note / Test condition
		Min.	Typ.	Max.		
Compression point 0.1 dB¹⁾						
P0.1dB	$P_{0.1dB}$	30	–	–	dBm	
Harmonic generation¹⁾ at $P_{RF} = 24\text{ dBm}$, CW-mode, $Z_0 = 50\ \Omega$						
2 nd Harmonic	$P_{H2,WIFI}$	–	–79	–56	dBm	2400 MHz
		–	–67	–40	dBm	5800 MHz
		–	–67	–40	dBm	7100 MHz
3 rd Harmonic	$P_{H3,WIFI}$	–	–58	–54	dBm	2400 MHz
		–	–67	–54	dBm	5800 MHz
		–	–68	–51	dBm	7100 MHz
Error vector magnitude¹⁾ of WIFI signal (802.11ac, VHT40, MCS9) at $P_{RF} = 24\text{ dBm}$						
EVM	EVM	–	–49	–44	dB	2450 MHz
Intercept point¹⁾ at $P_{RF} = 20\text{ dBm}$ /tone						
IIP3 2.4 GHz band	$IIP3_{2.4,WIFI}$	58	63	–	dBm	2400 MHz
IIP3 5–7 GHz band	$IIP3_{5-7,WIFI}$	60	66	–	dBm	6000 MHz

¹⁾ Measured on application board, without any matching components.

Table 7: Cellular RF characteristics at $T_A = -40\text{ °C} \dots 85\text{ °C}$, $P_{RF} = 0\text{ dBm}$, $V_{DD} = 1.65\text{ V} \dots 3.6\text{ V}$, unless otherwise specified

Parameter	Symbol	Values			Unit	Note / Test condition
		Min.	Typ.	Max.		
Harmonic generation¹⁾ at $P_{RF} = 26\text{ dBm}$, CW-mode, $Z_0 = 50\ \Omega$						
2 nd Harmonic	$P_{H2,cellular}$	–	–74	–65	dBm	600–915 MHz
		–	–76	–67	dBm	1447–1980 MHz
		–	–83	–60	dBm	2300–2690 MHz
3 rd Harmonic	$P_{H3,cellular}$	–	–68	–60	dBm	600–915 MHz
		–	–68	–60	dBm	1447–1980 MHz
		–	–64	–60	dBm	2300–2690 MHz
Intermodulation distortion¹⁾						
IMD2	$IMD2$	–	–112	–103	dBm	Testcases see Table 8
IMD3	$IMD3$	–	–116	–109	dBm	Testcases see Table 9
Intercept point¹⁾						
IIP2	$IIP2$	108	117	–	dBm	Testcases see Table 8
IIP3	$IIP3$	67	70	–	dBm	Testcases see Table 9

¹⁾ Measured on application board, without any matching components.

RF characteristics

Table 8: Cellular IMD2 testcases

Band	Symbol	In-band frequency (MHz)	Blocker frequency 1 (MHz)	Blocker power 1 (dBm)	Blocker frequency 2 (MHz)	Blocker power 2 (dBm)
Band 1	$B1_{\text{IMD2,high}}$	2140	1950	20	4090	-15
	$B1_{\text{IMD2,low}}$	2140	1950	20	190	-15
Band 4	$B4_{\text{IMD2,high}}$	2132	1732	20	3864	-15
	$B4_{\text{IMD2,low}}$	2132	1732	20	400	-15
Band 5	$B5_{\text{IMD2,high}}$	881.5	836.5	20	1718	-15
	$B5_{\text{IMD2,low}}$	881.5	836.5	20	45	-15
Band 7	$B7_{\text{IMD2,high}}$	2655	2535	20	5190	-15
	$B7_{\text{IMD2,low}}$	2655	2535	20	120	-15

Table 9: Cellular IMD3 testcases

Band	Symbol	In-band frequency (MHz)	Blocker frequency 1 (MHz)	Blocker power 1 (dBm)	Blocker frequency 2 (MHz)	Blocker power 2 (dBm)
Band 1	$B1_{\text{IMD3,high}}$	2140	1950	20	6040	-15
	$B1_{\text{IMD3,mid}}$	2140	1950	20	1760	-15
Band 4	$B4_{\text{IMD3,high}}$	2132	1732	20	5596	-15
	$B4_{\text{IMD3,mid}}$	2132	1732	20	1332	-15
Band 5	$B5_{\text{IMD3,high}}$	881.5	836.5	20	2554.5	-15
	$B5_{\text{IMD3,mid}}$	881.5	836.5	20	791.5	-15
Band 7	$B7_{\text{IMD3,high}}$	2655	2535	20	7725	-15
	$B7_{\text{IMD3,mid}}$	2655	2535	20	2415	-15

BGS12WN6

0.05–9 GHz SPDT switch with fast switching speed

RF characteristics

Table 10: Switching time at $T_A = -40\text{ }^{\circ}\text{C} \dots 85\text{ }^{\circ}\text{C}$, $P_{RF} = 0\text{ dBm}$, $V_{DD} = 1.65\text{ V} \dots 3.6\text{ V}$, unless otherwise specified

Parameter	Symbol	Values			Unit	Note / Test condition
		Min.	Typ.	Max.		
Switching time¹⁾						
Switching time	t_{ST}	–	160	220	ns	Time between RF states in active mode $V_{Ctrl,H}$ Min. or $V_{Ctrl,L}$ max. level to 90% RF-signal
RF rise time	t_{RT}	–	35	80	ns	Time between 10% to 90% RF-signal
Power up settling time	t_{PUP}	–	5.8	7	μs	Time from V_{DD} Min. power level to 90% RF-signal

¹⁾ Measured on application board, without any matching components.

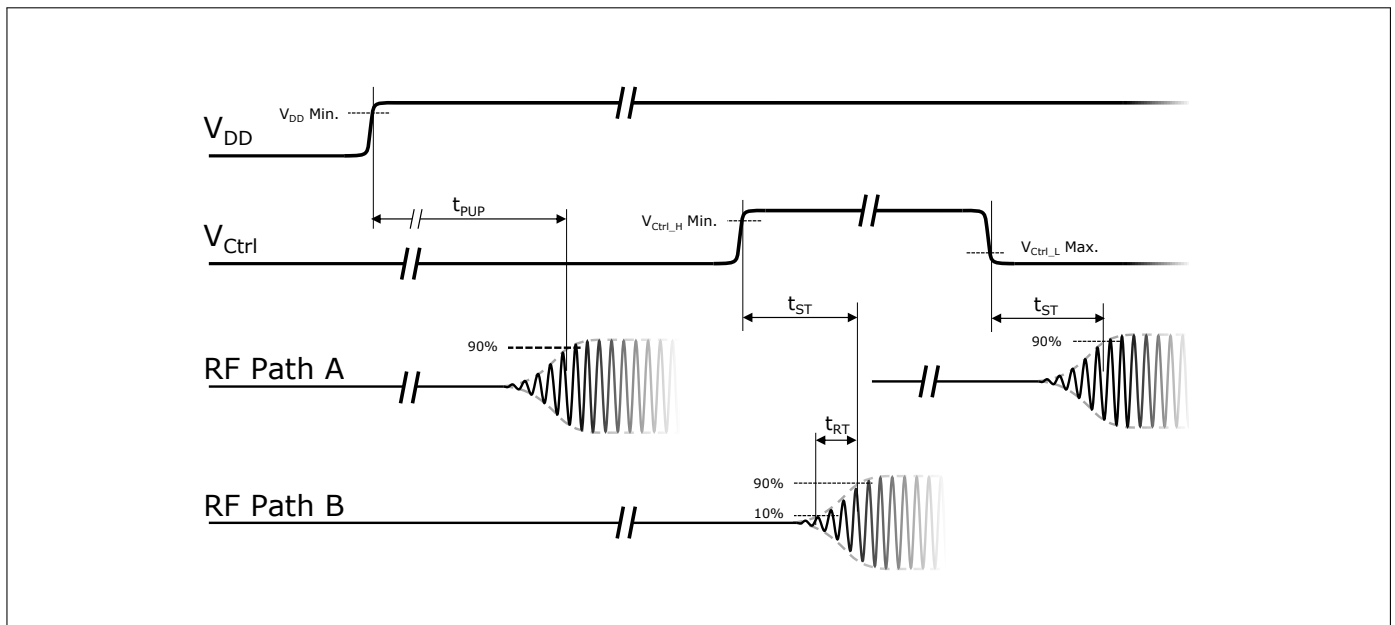

Figure 1: CTRL to RF time

BGS12WN6

0.05–9 GHz SPDT switch with fast switching speed

Application information

4 Application information

Pin configuration and function

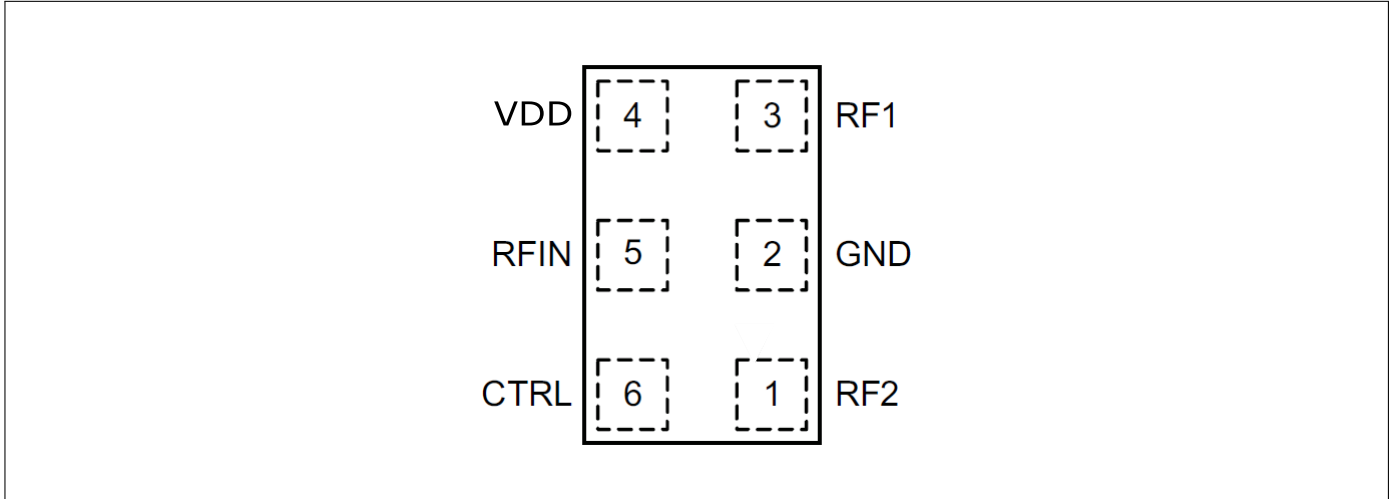

Figure 2: BGS12WN6 Pin configuration (top view)

Table 11: Pin definition and function

Pin No.	Name	Function
1	RF2	RF port 2
2	GND	Ground
3	RF1	RF port 1
4	VDD	Supply voltage
5	RFIN	RF port In
6	CTRL	Control pin

Table 12: Truth table switch control

Switched paths	CTRL
RFIN - RF1	0
RFIN - RF2	1

BGS12WN6

0.05–9 GHz SPDT switch with fast switching speed

Package information

5 Package information

Table 13: Mechanical data

Parameter	Symbol	Value	Unit
X-dimension	X	0.7 ± 0.05	mm
Y-dimension	Y	1.1 ± 0.05	mm
Size	Size	0.77	mm ²
Height PG-TSNP-6-10	H	$0.37 + 0.03 / - 0.02$	mm
Height PG-TSNP-6-2	H	$0.375 + 0.025 / - 0.015$	mm

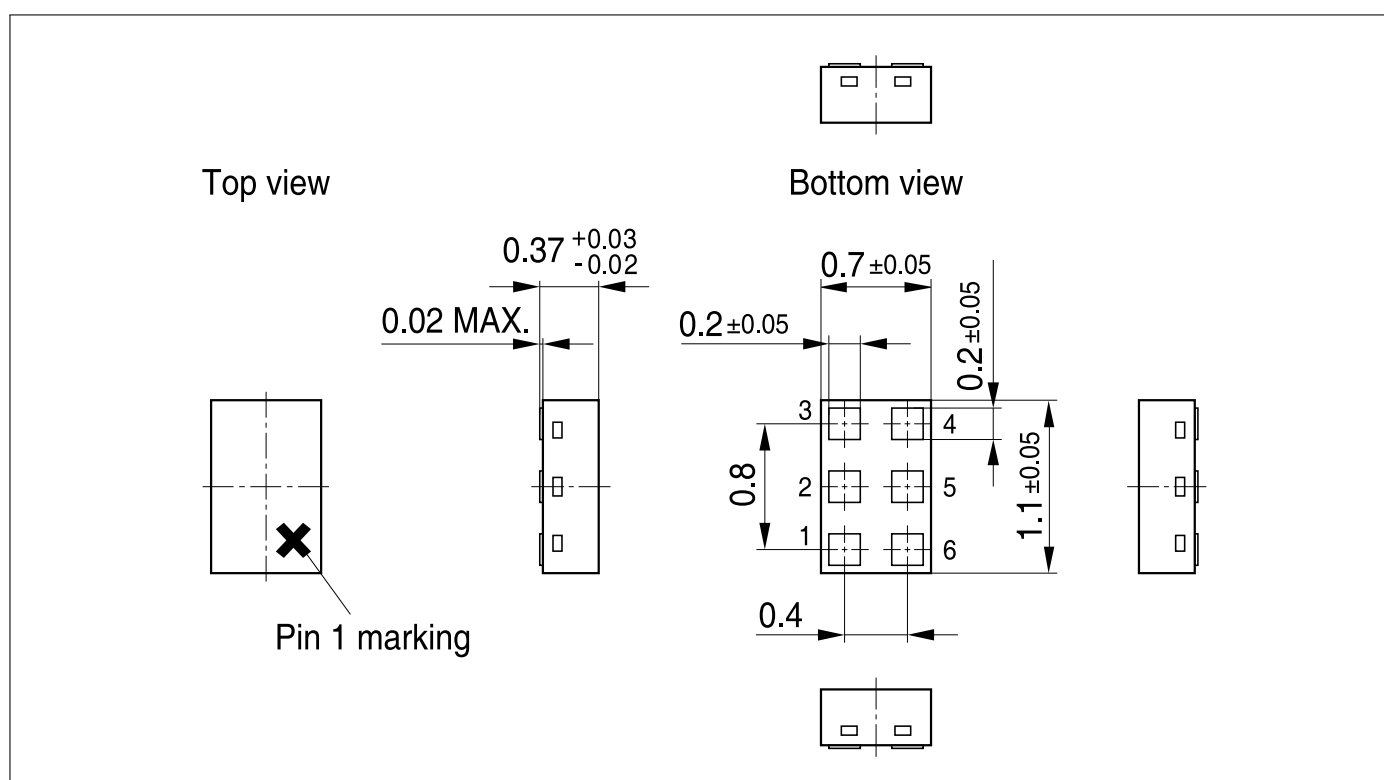

Figure 3: PG-TSNP-6-10 package outline (top, side and bottom views)

BGS12WN6

0.05–9 GHz SPDT switch with fast switching speed

Package information

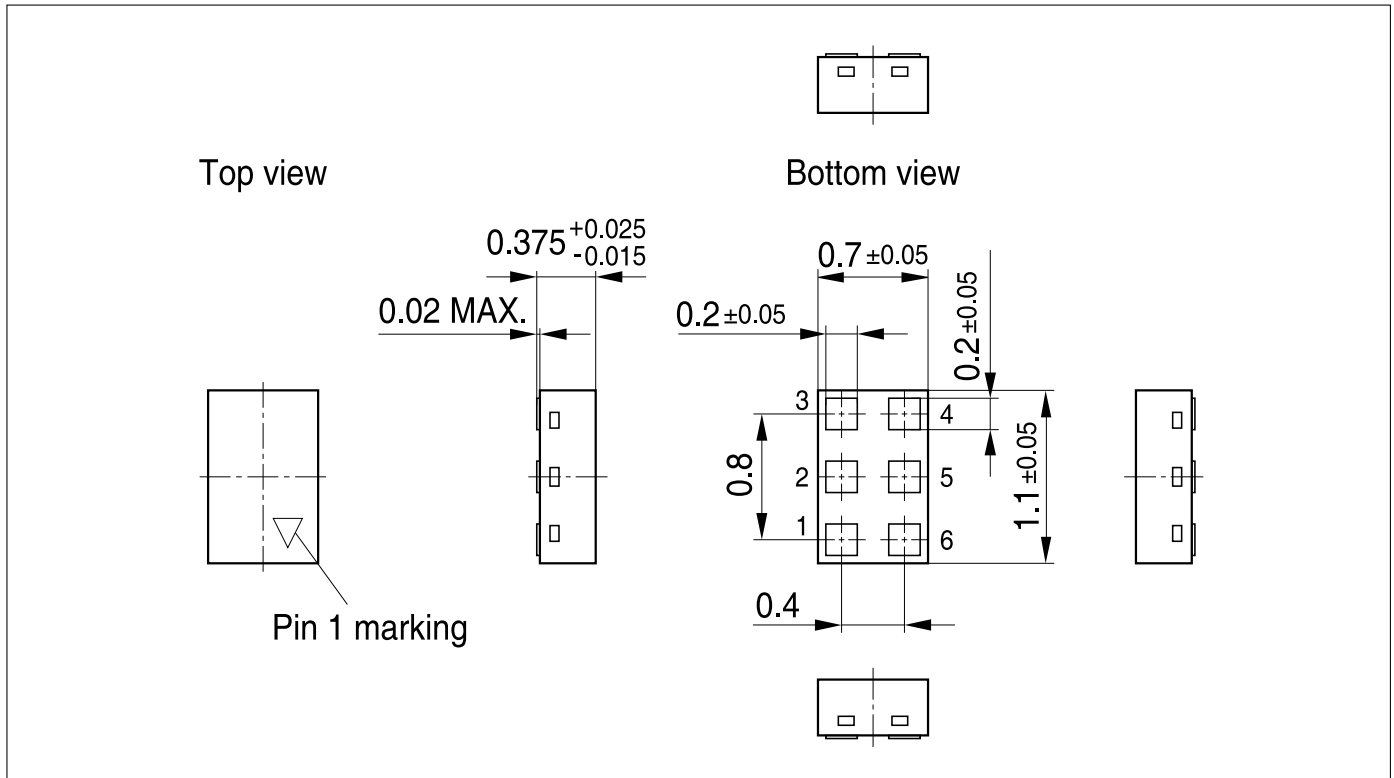

Figure 4: PG-TSNP-6-2 package outline (top, side and bottom views)

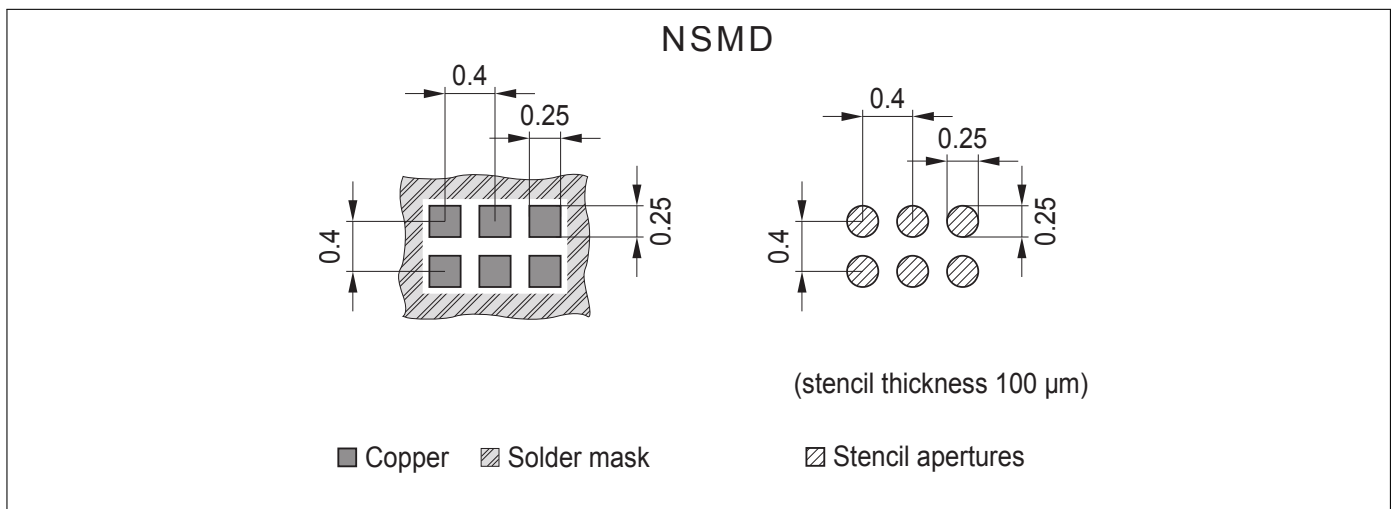

Figure 5: Footprint recommendation

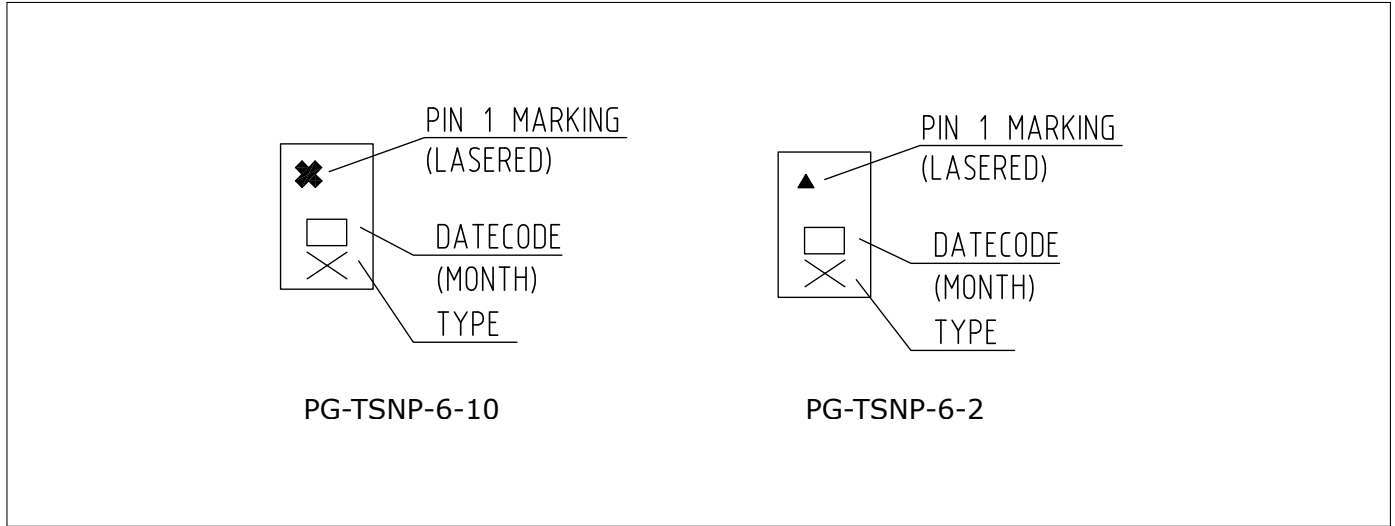

Figure 6: Marking specification (top view). Monthly date code specified in Table 14.

Table 14: Monthly date code marking

Month	2018	2019	2020	2021	2022	2023	2024	2025	2026
1	P	a	p	A	P	a	p	A	P
2	Q	b	q	B	Q	b	q	B	Q
3	R	c	r	C	R	c	r	C	R
4	S	d	s	D	S	d	s	D	S
5	T	e	t	E	T	e	t	E	T
6	U	f	u	F	U	f	u	F	U
7	V	g	v	G	V	g	v	G	V
8	X	h	x	H	X	h	x	H	X
9	Y	j	y	J	Y	j	y	J	Y
10	Z	k	z	K	Z	k	z	K	Z
11	4	l	2	L	4	l	2	L	4
12	5	n	3	N	5	n	3	N	5

BGS12WN6

0.05–9 GHz SPDT switch with fast switching speed

Package information

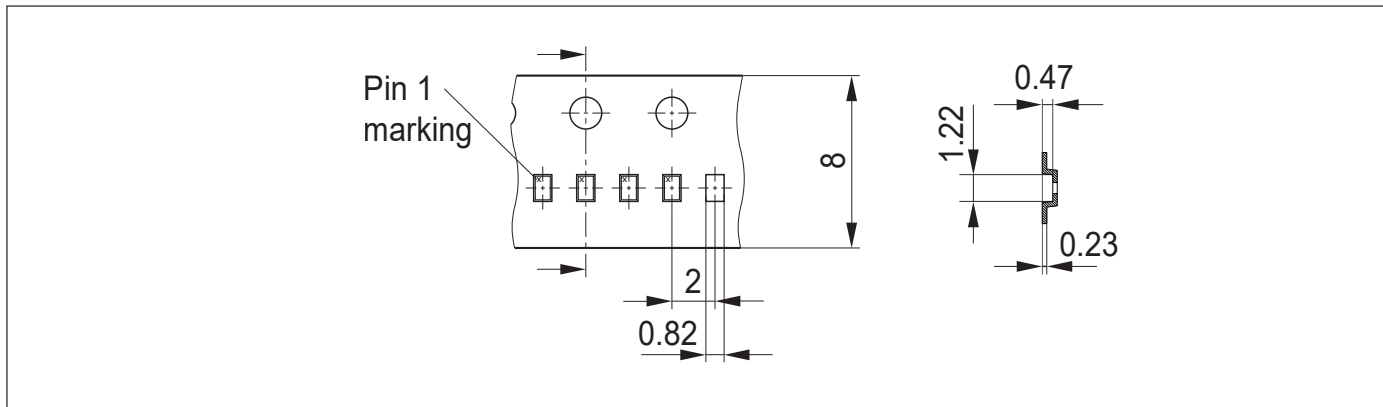

Figure 7: PG-TSNP-6-10 carrier tape drawing (top and side view)

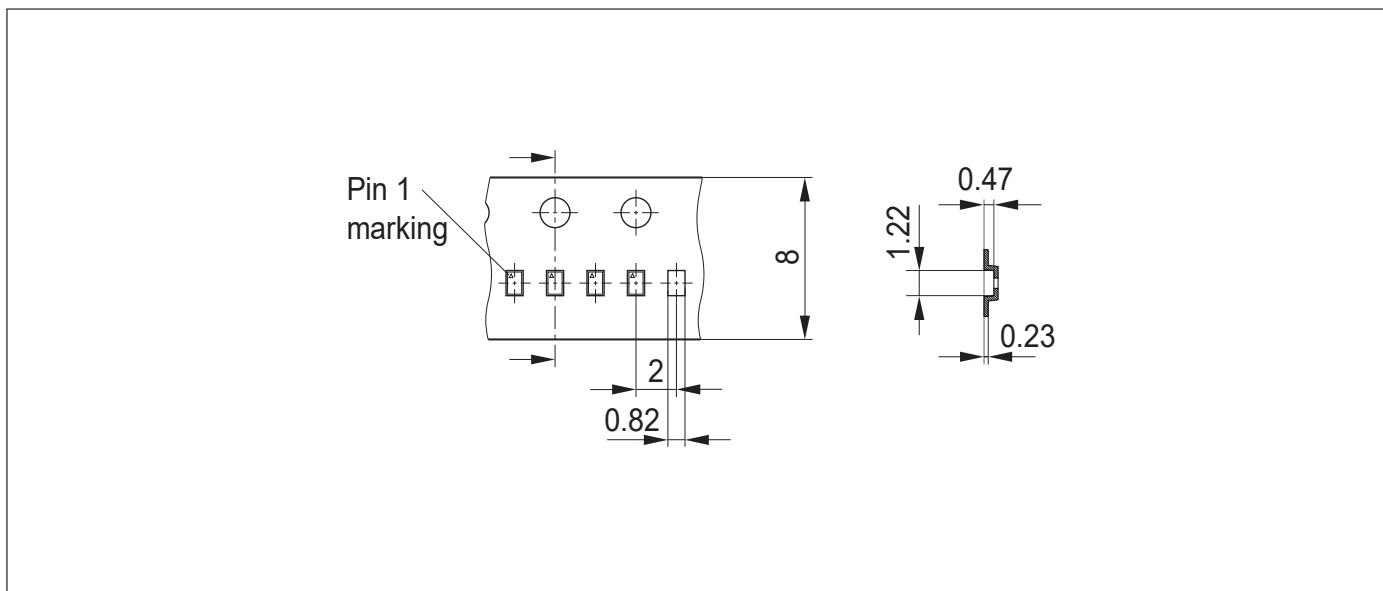

Figure 8: PG-TSNP-6-2 carrier tape drawing (top and side view)

BGS12WN6

0.05–9 GHz SPDT switch with fast switching speed



Revision History

Revision v2.7, 2023-04-12

Page or Item	Subjects (major changes since previous revision)
--------------	--

Revision 2.8, 2024-11-19

0	Title page updated
4	Control voltage and supply current for different control voltage high levels added in Table 2
6	WIFI characteristics added in Table 6 (IIP3, EVM)

Other Trademarks

All referenced product or service names and trademarks are the property of their respective owners.

Edition 2024-11-19
Published by
Infineon Technologies AG
81726 Munich, Germany

© 2024 Infineon Technologies AG.
All Rights Reserved.

Do you have a question about any aspect of this document?
Email: erratum@infineon.com

IMPORTANT NOTICE

The information given in this document shall in no event be regarded as a guarantee of conditions or characteristics ("Beschaffenheitsgarantie"). With respect to any examples, hints or any typical values stated herein and/or any information regarding the application of the product, Infineon Technologies hereby disclaims any and all warranties and liabilities of any kind, including without limitation warranties of non-infringement of intellectual property rights of any third party. In addition, any information given in this document is subject to customer's compliance with its obligations stated in this document and any applicable legal requirements, norms and standards concerning customer's products and any use of the product of Infineon Technologies in customer's applications. The data contained in this document is exclusively intended for technically trained staff. It is the responsibility of customer's technical departments to evaluate the suitability of the product for the intended application and the completeness of the product information given in this document with respect to such application.

For further information on technology, delivery terms and conditions and prices, please contact the nearest Infineon Technologies Office (www.infineon.com).

WARNINGS

Due to technical requirements products may contain dangerous substances. For information on the types in question please contact your nearest Infineon Technologies office.

Except as otherwise explicitly approved by Infineon Technologies in a written document signed by authorized representatives of Infineon Technologies, Infineon Technologies products may not be used in any applications where a failure of the product or any consequences of the use thereof can reasonably be expected to result in personal injury.

Looking for pricing, stock, or lifecycle information?

Click below to explore more details on WIN SOURCE:

- ⊖ [View BGS12WN6E6327XTSA1 on WIN SOURCE](#)
- ⊖ [Infineon Technologies Information](#)

Optimize Your Supply Chain with WIN SOURCE Solutions

- ✓ Global Sourcing Solution
- ✓ Obsolete Management
- ✓ Cost Control Management
- ✓ Shortage Management
- ✓ Alternative Solution
- ✓ Excess Inventory Management