



THE DATASHEET OF
0026A0024-9X





CABLE, HIGH-FREQUENCY AND CONTROLLED ELECTRICAL

1. SCOPE

1.1 SCOPE

This specification covers inspection methods, procedures and requirements for high-frequency and controlled electrical cables.

1.2 TEMPERATURE RATING

The temperature rating, when shown on the specification sheet, is based on data obtained from either testing of the insulation material(s) using the mechanical and electrical integrity of the product as defined by ASTM D 3032, Section 14, as the basis for the rating, or by industry-defined standards for the type of material. The temperature rating is not based on possible changes to the electrical characteristics of the cable which might occur as a result of exposure to temperature extremes.

2. APPLICABLE DOCUMENTS

2.1 GOVERNMENT-FURNISHED DOCUMENTS

The following documents, of the issue in effect on the date of invitation for bids or request for proposal, form a part of this specification to the extent specified herein.

2.1.1 Department of Defense

SPECIFICATIONS

Federal

UU-T-450 Tissue, Facial

Military

MIL-DTL-17 Cables, Radio Frequency, Flexible and Semirigid, General Specification For

MIL-DTL-915 Cable, Electrical, for Shipboard Use, General Specification For

(Copies of Department of Defense documents may be obtained from the Naval Publications and Forms Center, Standardization Documents Order Desk, 700 Robbins Ave., Bldg. 4D, Philadelphia, PA 19111-5094; or at <http://assist.daps.dla.mil/quicksearch/>.)

2.1.2 Department of Transportation, Federal Aviation Administration

FEDERAL AVIATION REGULATIONS (FAR)

Part 25 Airworthiness Standards: Transport Category Airplanes

(Copies of Department of Transportation, Federal Aviation Administration documents may be obtained from the Superintendent of Documents, Government Printing Office, Washington, D.C. 20402; or at www.faa.gov.)

2.2 OTHER PUBLICATIONS

The following documents, of the issue in effect on the date of invitation for bids or request for proposal, form a part of this specification to the extent specified herein.

2.2.1 American Society for Quality (ASQ)

ASQ Z1.4 Sampling Procedures and Tables for Inspection by Attributes

(Copies of ASQ documents may be obtained from the American Society for Quality, 600 North Plankinton Avenue, Milwaukee, WI 53203; or at www.asq.org.)

2.2.2 American Society for Testing and Materials (ASTM)

B 193 Standard Test Method for Resistivity of Electrical Conductor Materials

D 3032 Standard Test Methods for Hookup Wire Insulation

D 4566 Standard Test Methods for Electrical Performance Properties of Insulations and Jackets for Telecommunications Wire and Cable

E 595 Standard Test Method for Total Mass Loss and Collected Volatile Condensable Materials from Outgassing in a Vacuum Environment

(Copies of ASTM documents may be obtained from the American Society for Testing and Materials, 100 Barr Harbor Drive, West Conshohocken, PA 19428-2959; or at www.astm.org.)

2.2.3 Canadian Standards Association (CSA)

C22.2 No. 0.3 Test Methods for Electrical Wires and Cables

(Copies of CSA documents may be obtained from the Canadian Standards Association, 5060 Spectrum Way, Suite 100, Mississauga, Ontario, Canada L4W 5N6; or at www.shopcsa.ca.)

2.2.4 Electronic Components Industry Association (ECIA)

EIA-364-108 TP-108, Impedance, Reflection Coefficient, Return Loss, and VSWR Measured in the Time and Frequency Domain Test Procedure for Electrical Connectors, Cable Assemblies or Interconnection Systems

(Copies of ECIA documents may be obtained from the Electronic Components Industry Association, 1111 Alderman Drive, Suite 400, Alpharetta, GA 30005; or at www.ecianow.org.)

2.2.5 International Organization for Standardization (ISO)

8402 Quality Management and Quality Assurance - Vocabulary

(Copies of ISO documents may be obtained from the International Organization for Standardization; or at www.iso.org.)

2.2.6 National Electrical Manufacturers Association (NEMA)

WC 61 Transfer Impedance Testing

WC 27500 American National Standard for Aerospace and Industrial Electrical Cable

(Copies of NEMA documents may be obtained from the National Electrical Manufacturers Association, 1300 North 17th Street, Suite 900, Rosslyn, VA 22209; or at www.nema.org.)

2.2.7 Society of Automotive Engineers (SAE)

AS4373 Test Methods for Insulated Electric Wire

AS22759 Wire, Electrical, Fluoropolymer-Insulated, Copper or Copper Alloy

AS29606 Wire, Electrical, Stranded, Uninsulated Copper, Copper Alloy, or Aluminum, or Thermocouple Extension, General Specification For

J1128 Low Voltage Primary Cable

(Copies of SAE documents may be obtained from the Society of Automotive Engineers, 400 Commonwealth Drive, Warrendale, PA 15096-0001; or at www.sae.org.)

2.2.8 Underwriters Laboratories (UL)

UL 1581 Reference Standard for Electrical Wires, Cables and Flexible Cords

(Copies of UL documents may be obtained from Underwriters Laboratories Inc., 1655 Scott Boulevard, Santa Clara, CA 95050-4169; or at www.ul.com.)

3. REQUIREMENTS

3.1 SPECIFICATION SHEETS

The requirements for the individual cables furnished under this specification shall be as specified herein and in accordance with the applicable specification sheet. In the event of a conflict, the requirements of the specification sheet shall govern.

3.2 MATERIALS

Materials not specifically designated herein shall be of the quality and form best suited for the purpose intended. Unless otherwise specified, the materials shall meet the following requirements:

3.2.1 Conductor Material

Conductor material shall be as specified in the applicable specification sheet and shall meet the material requirements for that type as specified in AS29606.

3.2.2 Shield Material

Shield material shall be as specified in the applicable specification sheet and shall meet the material requirements for that type as specified in WC 27500.

3.2.3 Insulating Materials

Insulating materials, used for wire insulation or cable jackets, shall be in accordance with the applicable specification sheet.

3.3 CONSTRUCTION

Construction of the finished cable shall be as specified herein and in the applicable specification sheet.

3.3.1 Conductor

Unless otherwise specified in the applicable specification sheet, the conductor construction shall be in accordance with AS29606.

3.3.1.1 Conductor Elongation and Breaking Strength

Prior to dielectric extrusion, elongation and breaking strength of the conductor shall be in accordance with AS29606 for the AWG, construction, and material specified in the applicable specification sheet. Other materials not covered by AS29606 shall be in accordance with the applicable specification sheet.

3.3.2 Shields

3.3.2.1 Braided Shields

The shield shall be constructed so as to meet all physical and surface transfer impedance requirements of the applicable specification sheet. The shield shall be free of irregularities, discontinuities, and whole braid splices.

3.3.2.2 Foil Shields and Drain Wires

Foil shields and drain wires shall meet the requirements of the applicable specification sheet.

3.3.3 Wraps

Tape wraps, when required, shall be applied with an overlap of 25 percent minimum, unless otherwise specified, and shall meet the material and construction requirements specified in the applicable specification sheet. Tape overlap shall be determined in accordance with 4.5.37.

3.3.4 Insulating Materials

Insulating materials, used for wire insulation or cable jackets, shall be constructed as specified in the applicable specification sheet.

3.4 DETAIL REQUIREMENTS

Finished cable shall conform to the requirements of Table 1 and to those of the applicable specification sheet.

3.4.1 Blocking

When required by the specification sheet and tested in accordance with 4.5.3, adjacent turns and layers of the finished cable shall not block. Blocking shall be defined as a transfer of material between adjacent surfaces when they are separated.

3.4.2 Cabling

The required number of components as specified in the applicable specification sheet shall be cabled together with a left-hand lay. The lay length of the components, when required, shall be as specified in the applicable specification sheet.

3.4.3 Conductor and Shield Continuity

Prior to shipment, one hundred percent of all finished cable shall be tested for continuity in accordance with 4.5.7. There shall be no indication of discontinuity in any of the component wires or shields, as applicable.

3.4.4 Dielectric Concentricity

Where required, the dielectric concentricity shall be in accordance with the applicable specification sheet when tested in accordance with 4.5.9.

TABLE 1. PROPERTIES OF FINISHED CABLE

Examination or Test	Requirement	Test Method	*Inspection Class
ACRF	Specification Sheet	ASTM D 4566, Section 28	P
Adhesion of Conductor	Specification Sheet	4.5.1	P
Attenuation (Insertion Loss)	Specification Sheet	4.5.2	P
Blocking	Specification Sheet and 3.4.1	4.5.3	P
Cabling	Specification Sheet and 3.4.2	4.5.14	P
Capacitance	Specification Sheet	4.5.4	P
Capacitance Unbalance	Specification Sheet	4.5.5	P
Characteristic Impedance	Specification Sheet	4.5.6	P
Color	Specification Sheet	4.5.14	P
Conductor Elongation and Breaking Strength	3.3.1.1	AS29606	V
Conductor and Shield Continuity	3.4.3	4.5.7	100%
Conductor and Shield Resistance	Specification Sheet	4.5.8	P
Conductor Splices	AS29606	4.5.14	V
Construction and Materials	Specification Sheet, 3.2 and 3.3	4.5.14	P
Dielectric Concentricity	3.4.4	4.5.9	P
Dielectric/Jacket Elongation and Tensile Strength	Specification Sheet	4.5.10	P
Differential Impedance	Specification Sheet	4.5.11	P
Dimensional Stability	Specification Sheet	4.5.12	P
Dimensions	Specification Sheet	4.5.13	P
ELTCL	Specification Sheet	ASTM D 4566, Section 51	P
Eye Pattern	Specification Sheet	4.5.15	P
FEXT	Specification Sheet	4.5.16	P
Flammability	Specification Sheet and 3.4.5	4.5.17	P
Heat Shock	Specification Sheet	4.5.18	P
Insulation Resistance	Specification Sheet	4.5.19	P
Jacket Concentricity	3.4.6	4.5.20	P
Jacket Flaws	Specification Sheet and 3.4.7	4.5.21	100%
Jacket Wall Thickness	Specification Sheet	4.5.20	P
LCL	Specification Sheet	ASTM D 4566, Section 51	P
Low Temperature-Cold Bend	Specification Sheet and 3.4.8	4.5.22	P
NEXT	Specification Sheet	4.5.23	P
Partial Discharge (Corona Extinction Voltage)	Specification Sheet	4.5.24	P
Propagation Delay	Specification Sheet	ASTM D 4566, Section 45	P
Propagation Delay Skew	Specification Sheet	4.5.25	P
PSACRF	Specification Sheet	ASTM D 4566, Section 28	P
PSNEXT	Specification Sheet	ASTM D 4566, Section 25	P
Radiation Resistance	Specification Sheet	4.5.26	1/
Return Loss	Specification Sheet	ASTM D 4566, Section 50	P
Shield Coverage	Specification Sheet	4.5.27	P
Skew (Within Pair)	Specification Sheet	4.5.28	P
Structural Return Loss	Specification Sheet	4.5.29	P
Surface Transfer Impedance	Specification Sheet	4.5.30	P
TCL	Specification Sheet	ASTM D 4566, Section 51	P
Time Delay	Specification Sheet	4.5.31	P

TABLE 1. PROPERTIES OF FINISHED CABLE (Continued)

Examination or Test	Requirement	Test Method	*Inspection Class
UV Laser Mark Contrast	Specification Sheet and 3.4.9	AS4373, Method 1001	P
Vacuum Stability	Specification Sheet	4.5.32	<u>1</u> /
Velocity of Propagation	Specification Sheet	4.5.33	P
Voltage Withstand (Dielectric)	Specification Sheet	4.5.34.1	100%
Weight	Specification Sheet	4.5.35	P
Weight Loss	Specification Sheet and 3.4.10	4.5.36	P
Workmanship	3.4.11	4.5.14	P
Wraps	Specification Sheet and 3.3.3	4.5.37	P

***Inspection Class (see 4.2):**

P = In-Process or Lot Test

V = Vendor Test

100% = 100% Finished Product Test

1/ = Radiation Resistance and Vacuum Stability testing shall be performed at a frequency that has been agreed upon between the customer and TE Connectivity.**3.4.5 Flammability**

Finished cable shall be tested in accordance with 4.5.17 to the appropriate method as specified in the applicable specification sheet. Unless otherwise specified, finished cable shall meet the following requirements:

3.4.5.1 Method A, Vertical Test, Inclined Burner

60 seconds (maximum)
25 percent (maximum) of flag burned
No flaming of cotton

3.4.5.2 Method B, 60° Test, Inclined Burner

30 seconds (maximum)
3 inches (76 mm) (maximum)
No flaming of facial tissue

3.4.5.3 Method C, Horizontal Test, Vertical Burner

No flaming of indicator papers.

3.4.5.4 Method D, 45° Test, Inclined Burner

70 seconds (maximum)

3.4.6 Jacket Concentricity

When finished cable is tested in accordance with 4.5.20, the jacket concentricity shall be 70 percent, minimum, unless otherwise specified in the applicable specification sheet.

3.4.7 Jacket Flaws

One hundred percent of finished shielded and jacketed cable shall pass the impulse test or the spark test specified in 4.5.21 using the voltage specified in the applicable specification sheet. Testing shall be performed during the final winding of the cable on shipment spools or reels.

3.4.8 Low Temperature-Cold Bend

When finished cable is tested in accordance with 4.5.22, there shall be no cracking of the jacket and, when applicable, no breakdown of the jacket.

3.4.9 UV Laser Mark Contrast

When required by the specification sheet, the finished cable outer surface shall be ultraviolet (UV) laser markable. The mark shall meet a minimum contrast level as specified in the applicable specification sheet.

3.4.10 Weight Loss

When required by the specification sheet and tested in accordance with 4.5.36, specimens of cable with woven or spiral, round or flat, shielding shall not exceed the weight loss specified.

3.4.11 Workmanship

All details of workmanship shall be in accordance with high grade wire and cable manufacturing practices. The dielectric and jacket shall be free of cracks, splits, irregularities, and imbedded foreign material.

4. **QUALITY ASSURANCE PROVISIONS**

4.1 RESPONSIBILITY FOR INSPECTION

The supplier is responsible for the performance of all the inspection tests specified herein. The supplier may utilize his own or any other inspection facility and services acceptable to the buyer. Inspection records of the examinations and tests shall be kept complete and available to the buyer as required.

4.2 INSPECTION CLASSIFICATION

- a. Vendor Control (V): Requirements for raw materials such as conductor and insulation materials over which the vendor has control and responsibility.
- b. Process Control (P): Inspections performed on samples taken from the lots of cable. Inspections may be performed on finished cable or after the process which establishes the specified characteristic. The Quality Control Plan establishes the frequency of inspection based on process control data.
- c. One Hundred Percent (100%): Tests performed on the total length of each cable. Tests may be performed on the finished product or "in process", as applicable.

4.3 INSPECTION CONDITIONS

Unless otherwise specified herein, all test inspection conditions shall be in accordance with the following:

- a. Temperature: $25 \pm 10^{\circ}\text{C}$
- b. Relative humidity: 60 ± 15 percent
- c. Atmospheric pressure: 725 ± 76 mm of mercury

4.4 QUALITY CONFORMANCE INSPECTION

Quality conformance inspection consists of a series of tests and inspections that assure that raw materials and manufacturing processes are consistent and result in products that conform to specification requirements. Quality conformance tests and inspections are listed in Table 1, designated as "P", "V", or "100%", and shall be performed on every lot of cable procured under this specification.

4.4.1 Inspection Definitions

ISO 8402 shall apply for definitions of inspection terms used herein. For purposes of this specification, the following shall apply:

4.4.1.1 Lot

The inspection lot shall include all cable of one part number subjected to inspection at one time.

4.4.2 Nonconforming Inspection Lots

Disposition of material found unacceptable under quality conformance inspection shall be in accordance with ASQ Z1.4.

4.5 TEST METHODS

4.5.1 Adhesion of Conductor

4.5.1.1 Specimen Preparation

Two specimens shall be cut to the length shown in Figure 1 using shear-type cutters to minimize cross-sectional distortion. The jacket and shield shall be cut and carefully removed without bending or flexing the cable. The dielectric shall be removed using a razor blade without disturbing the remaining dielectric.

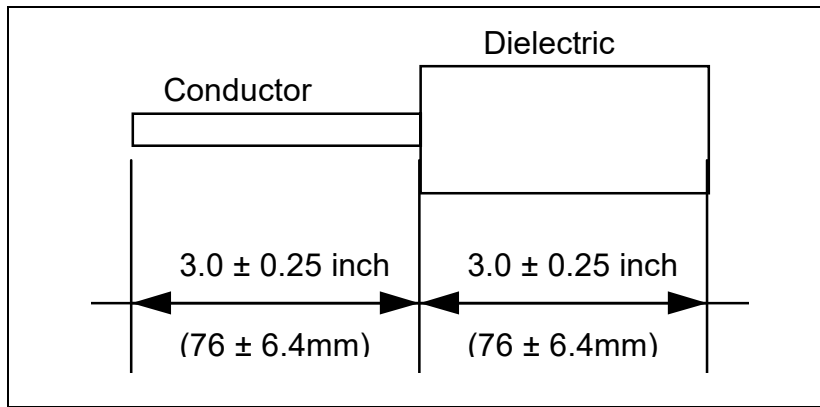

FIGURE 1.

Conductor Adhesion Stripping Dimensions

4.5.1.2 Apparatus

A test fixture capable of being held in a tensile testing machine and providing a hole for the conductor to pass through shall be used. Clearance holes for conductors shall be no smaller than the diameter of the conductor plus 0.002 inch (0.05 mm) and no larger than the smallest practicable numerical drill size.

4.5.1.3 Procedure

With the conductor passing through the appropriate hole, the conductor shall be clamped in one set of jaws while the test fixture is held or supported by the other set of jaws. The jaws shall be separated at a rate of 0.5 inch (13 mm) per minute and the force recorded while the conductor is pulled out of the dielectric. The maximum force recorded shall be designated as the strip force and shall meet the requirements of the applicable specification sheet.

4.5.1.4 Test Method Derivation

The preceding test method is derived from the Adhesion of Conductors test method in MIL-DTL-17.

4.5.2 Attenuation (Insertion Loss)

4.5.2.1 Specimen

The specimen shall be of sufficient length to exhibit at least 3 dB of attenuation at the lowest frequency required. The specimen shall be short enough to ensure that the measured signal is at least 10 dB higher than the measuring system noise floor. If the frequency range is such that one specimen cannot fulfill this requirement, then an additional specimen of suitable length shall be used. For coaxial-type cables, suitable connectors shall be attached to both ends of the cable. For twisted pairs, a connector board with insulation displacement connectors may be used.

4.5.2.2 Procedure

An appropriate test set shall be used to measure the attenuation of the sample. Calibration and specimen measurements shall be made in accordance with the analyzer or system procedures. The attenuation at any frequency shall be determined from the following formula:

$$\text{Attenuation in dB/100 feet (or dB/100 m)} = \frac{\text{Measured Attenuation (dB)} \times 100}{\text{Specimen length in feet (or meters)}}$$

4.5.2.3 Determination of Compliance

Within the frequency range(s) specified in the applicable specification sheet, the attenuation shall not exceed the specified value. Due to reflections, it may be necessary to perform a standard regression analysis on the raw data. The regression polynomial used shall be:

$$A(f) = a_1\sqrt{f} + a_2f$$

Where:

f = frequency in MHz

a₁, a₂ = coefficients determined by regression analysis

A(f) = attenuation in dB/100 feet (or dB/100 m) at frequency (f)

The regression analysis is used to smooth out SWR effects. To determine compliance, the frequency (or frequencies) listed on the specification sheet shall be substituted into the above equation, along with the regression coefficients a₁ and a₂, and the attenuation A(f) calculated.

4.5.2.4 Test Method Derivation

The preceding test method is derived from the Attenuation test methods in MIL-DTL-17 and ASTM D 4566.

4.5.3 Blocking

One end of a finished cable specimen of sufficient length to perform the test shall be affixed to a metal mandrel as specified in the applicable specification sheet. The cable shall then be spirally wound around the mandrel so at least three turns are in close contact with one another. The winding shall be continued until there are three layers of turns with each layer in close contact with one another. The free end of the cable shall be affixed to the mandrel to prevent unwinding or loosening of the turns. The mandrel and cable shall then be conditioned in an air oven for the time and at the temperature specified in the applicable specification sheet. After conditioning, the mandrel and cable shall be removed from the oven and allowed to cool to room temperature. After cooling, the cable shall be unwound manually and examined for evidence of blocking.

4.5.3.1 Test Method Derivation

The preceding test method is derived from the Blocking test method in WC 27500.

4.5.4 Capacitance

4.5.4.1 Configuration

For coaxial and triaxial cables only, capacitance shall be measured with a capacitance bridge at 1 kHz, unless otherwise specified in the applicable specification sheet. For pair and triad cables, the frequency shall be 1 MHz, unless otherwise specified. If the frequency specified for shielded or unshielded pairs or triads is 1 kHz, an appropriate capacitance bridge that performs measurements in accordance with ASTM D 4566 may be used (i.e. local area network cables).

4.5.4.2 Specimen Preparation

For measuring a frequency of 1 MHz, the specimen shall consist of an approximate 10-foot (3-*m*) length of finished cable with all shields removed for a distance of 1 inch (25 *mm*) from each end and the insulation removed for a distance of 0.5 inch (13 *mm*) from the end of all conductors. The length of the specimen shall be the shielded length. For measuring frequencies other than 1 MHz, the sample shall be prepared as above except that the specimen length shall be less than 1/40 wavelength.

4.5.4.3 Procedure

4.5.4.3.1 *Coaxial Cables*

The capacitance (*C*) shall be measured between the inner conductor and outer conductor (shield) with the outer shield grounded.

4.5.4.3.2 *Shielded Pair Cables*

The capacitance between the two inner conductors shall be measured by the two-terminal method. With the outer conductor (shield) connected to the ground terminal of the capacitance bridge, the mutual capacitance shall be determined as follows:

Designate:

C_a = capacitance between no. 1 conductor and no. 2 conductor, with no. 2 conductor connected to the outer conductor

C_b = capacitance between no. 2 conductor and no. 1 conductor, with no. 1 conductor connected to the outer conductor

C_c = capacitance between no. 1 and no. 2 conductors connected together and the outer conductor

The mutual capacitance (C_m) per unit length for each shielded pair shall be determined using the following formula:

$$C_m = \frac{2(C_a + C_b) - C_c}{4(\text{Length of specimen})}$$

4.5.4.3.3 *Shielded Triad Cables*

The capacitance shall be measured by the two-terminal method. With the outer conductor (shield) connected to the ground terminal of the capacitance bridge, the mutual capacitance shall be determined as follows:

Designate:

C_a = capacitance between no. 1 conductor and all other conductors connected to the outer conductor

C_b = capacitance between no. 2 conductor and all other conductors connected to the outer conductor

C_c = capacitance between no. 3 and all other conductors connected together and the outer conductor

C_d = capacitance between no. 1, no. 2, and no. 3 conductors connected together and the outer conductor

The mutual capacitance (C_m) per unit length for each shielded triad shall be determined using the following formula:

$$C_m = \frac{3(C_a + C_b + C_c) - C_d}{12(\text{Length of specimen})}$$

4.5.4.3.4 *Unshielded Pair Cables*

For unshielded pairs, the procedure shall be the same as given for shielded pair cables except that the overall shield, if any, and all the conductors of the specimen, except the pair under test, shall be connected together and treated as the outer conductor when making measurements. The mutual capacitance (C_m) for each pair shall be determined by the formula specified for the shielded pairs.

4.5.4.3.5 *Unshielded Triad Cables*

For unshielded triad cables, the procedure shall be the same as given for shielded triads except that the overall shield, if any, and all conductors of the specimen, except those of the triad under test, shall be connected together and treated as the outer conductor when making measurements. The mutual capacitance (C_m) for each triad shall be determined by the formula specified for shielded triads.

4.5.4.4 Test Method Derivation

The preceding test methods are derived from the Capacitance test methods in MIL-DTL-17, MIL-DTL-915, and ASTM D 4566.

4.5.5 Capacitance Unbalance

4.5.5.1 Capacitance Unbalance to Shield

4.5.5.1.1 *Capacitance Unbalance Pair-to-Shield*

The capacitance shall be determined in accordance with 4.5.4. The capacitance unbalance (C_u) in percent shall be determined using the following formula:

$$C_u = \frac{400|C_a - C_b|}{2(C_a + C_b) - C_c} \%$$

4.5.5.1.2 *Capacitance Unbalance Triad-to-Shield*

The capacitance shall be determined in accordance with 4.5.4. The capacitance unbalance (C_u) in percent shall be determined using the following formula:

$$C_{u1} = \frac{200|C_a - C_b|}{(C_a + C_b)} \%$$

$$C_{u2} = \frac{200|C_b - C_c|}{(C_b + C_c)} \%$$

$$C_{u3} = \frac{200|C_a - C_c|}{(C_a + C_c)} \%$$

Where:

C_{u1} = percent of capacitance unbalance of conductor no. 1 in relation to conductor no. 2

C_{u2} = percent of capacitance unbalance of conductor no. 2 in relation to conductor no. 3

C_{u3} = percent of capacitance unbalance of conductor no. 3 in relation to conductor no. 1

4.5.5.1.3 *Test Method Derivation*

The preceding test methods are derived from the Capacitance Unbalance test method in MIL-DTL-17 and the Capacitance test method in MIL-DTL-915.

4.5.5.2 Capacitance Unbalance Pair-to-Pair

Capacitance unbalance between the pairs of a finished cable shall be measured using a suitable meter or bridge specifically designed for use with telephone cable. The cable sample shall be connected to the measuring instrument in accordance with the instrument manufacturer's procedure. The measurement frequency shall be 1 kHz. The capacitance unbalance of all adjacent and alternate pairs shall be measured as well as the capacitance unbalance between the pairs in adjacent layers. A lesser number of measurements may be made if allowed by the applicable specification sheet. The measured value of the capacitance unbalance for the particular sample under test shall be converted to an unbalance per 1000 feet (*or km*) by use of the following formula:

$$C_u = C_{uL} \sqrt{\frac{1000}{L}}$$

Where:

- C_u = capacitance unbalance in pF/1000 feet (*or pF/km*)
- C_{uL} = measured capacitance unbalance of sample in picofarads (pF)
- L = length of sample in feet (*or meters*)

4.5.5.2.1 Test Method Derivation

The preceding test method is derived from the Capacitance Unbalance Pair-to-Pair section of ASTM D 4566.

4.5.5.3 Capacitance Unbalance Pair-to-Ground

Capacitance unbalance between the pairs of finished cable and ground shall be measured using a suitable meter or bridge specifically designed for use with telephone cable. The cable sample shall be connected to the measuring instrument in accordance with the instrument manufacturer's procedure. The measurement frequency shall be 1 kHz. If a capacitance unbalance bridge is not available, the pair-to-ground capacitance unbalance shall be calculated using the following formula:

$$C_{upg} = (C_{ag} + C_{ap}) - (C_{bg} + C_{bp})$$

Where:

- C_{upg} = capacitance unbalance between pair and ground of sample in picofarads (pF)
- C_{ag} = capacitance between conductor "a" and ground
- C_{ap} = capacitance between conductor "a" and all other pairs in the cable connected together and grounded
- C_{bg} = capacitance between conductor "b" and ground
- C_{bp} = capacitance between conductor "b" and all other pairs in the cable connected together and grounded

The measured value of the capacitance unbalance for the particular sample under test shall be converted to an unbalance per 1000 feet (*or km*) using the following formula:

$$Y_1 = \frac{1000Y}{X}$$

Where:

- Y_1 = unbalance corrected to 1000 feet (*or km*)
- Y = unbalance of cable length
- X = cable length in feet (*or meters*)

4.5.5.3.1 Test Method Derivation

The preceding test method is derived from the Capacitance Unbalance Pair-to-Ground section of ASTM D 4566.

4.5.6 Characteristic Impedance

4.5.6.1 Characteristic Impedance - Method A

This method shall be used for cables whose nominal impedance is within 20 percent of Z_{ref} , where Z_{ref} is the impedance of the calibrated reference air line (CRAL). However, if the Time Domain Reflectometer (TDR) has the capability of displaying ohms at cursor, this method may also be used for cables whose nominal impedance falls outside 20 percent of the impedance of the CRAL.

4.5.6.1.1 *Method A Specimen Preparation*

For coaxial cable, attach a suitable connector at one end of the cable. For twisted pairs, the measurement is made wire-to-wire. Designate one wire as the inner conductor and the other wire as the outer conductor and attach a suitable connector at one end.

4.5.6.1.2 *Method A Apparatus*

The apparatus shall consist of a TDR with a maximum rise time of 150 picoseconds. A calibrated reference air line (CRAL) of suitable impedance and suitable connectors shall be used.

4.5.6.1.3 *Method A Procedure*

Attach the CRAL to the TDR output. If the TDR displays ohms at cursor, follow the instrument manufacturer's procedure. If not, designate the resulting trace as Z_{ref} and adjust horizontal magnifier control until Z_{ref} extends through at least six horizontal divisions. The sample cable shall then be attached and the resulting addition to Z_{ref} shall be designated as Z_c . With the cable attached, the Reflection Coefficient dial shall be adjusted so that Z_{ref} and Z_c are both on the graticule portion of the screen, but as far apart vertically as possible. Record the setting on the dial as A_{RC} . Determine the vertical spacing between Z_{ref} and Z_c in vertical divisions and designate as ρ_u . If Z_{ref} is higher than Z_c , then ρ_u is negative. If Z_{ref} is lower than Z_c , then ρ_u is positive.

Define "ρ" as: $\rho = \rho_u * A_{RC}$

Characteristic impedance, Z_o , shall be determined using the following formula:

$$Z_o = Z_{ref} \frac{1 + \rho}{1 - \rho}$$

4.5.6.1.4 *Method A Test Method Derivation*

The preceding test method is derived from the Characteristic Impedance test method in MIL-DTL-17.

4.5.6.2 Characteristic Impedance - Method B

This method shall be used for the determination of the characteristic impedance of coaxial cables only.

4.5.6.2.1 *Method B Procedure*

The velocity of propagation (V_p) shall be determined in accordance with ASTM D 4566. The capacitance (C) shall be determined in accordance with 4.5.4. The characteristic impedance shall be determined from the following relation:

$$Z_o = \frac{101670}{V_p (\%) * C (pF / ft)}$$

4.5.6.2.2 *Method B Test Method Derivation*

The preceding test method is derived from the Characteristic Impedance test method in MIL-DTL-17.

4.5.6.3 Characteristic Impedance - Method C

This method is appropriate for determination of the characteristic impedance of cables at specified frequencies of 1 MHz or higher.

4.5.6.3.1 *Method C Procedure*

Using a 1 MHz bridge, determine the capacitance (C) in accordance with 4.5.4. The end of the specimen used to determine the capacitance shall then be shorted and the inductance (L) of the specimen shall be determined using a 1 MHz bridge. Determination of the capacitance and inductance may also be made at other specified frequencies by use of a suitable bridge. For determining the characteristic impedance at frequencies higher than 1 MHz, the sample length should be shortened in order to minimize the effect of resonance. The characteristic impedance, at the specified frequency, shall be determined from the following relation:

$$Z_o = \sqrt{L/C}$$

Where: Z_o = characteristic impedance in ohms
 L = inductance in henries
 C = capacitance in farads

For multi-conductor cables, the capacitance (C) shall be the mutual capacitance (C_m).

4.5.6.3.2 *Method C Test Method Derivation*

The preceding test method is derived from the Characteristic Impedance test method in MIL-DTL-915.

4.5.6.4 Characteristic Impedance - Method D

This method is appropriate for determination of the characteristic impedance of data bus (balanced pair) cables at specified frequencies of 772 kHz or higher.

4.5.6.4.1 *Method D Procedure*

Using an appropriate bridge or measurement system, the open circuit impedance (Z_{oc}) and short circuit impedance (Z_{sc}) shall be measured. For determining the characteristic impedance at frequencies higher than 1 MHz, the sample length should be shortened in order to minimize the effect of resonance. The characteristic impedance, at the specified frequency, shall be determined from the following relation:

$$Z_o = \sqrt{Z_{oc} Z_{sc}}$$

Where:

Z_o = complex characteristic impedance in ohms

Z_{oc} = complex open circuit impedance in ohms

Z_{sc} = complex short circuit impedance in ohms

For electrically long lines (more than 1/8 of a wave length), the presence of structural variations influences the impedance observed at the measured end considerably, so that it is not actually Z_o but rather an input impedance (Z_{in}). For this situation, least squares function fitting techniques can be used to extract the characteristic impedance from the input impedance.

4.5.6.4.2 *Method D Test Method Derivation*

The preceding test method is derived from the Characteristic Impedance test method in ASTM D 4566.

4.5.7 Conductor and Shield Continuity

To establish continuity, 25 volts DC, maximum, shall be applied to both ends of each conductor and shield of the cable through an appropriate indicator, such as an ohmmeter, light, or buzzer. The test voltage may be applied to the conductors and shields individually, or in series.

4.5.7.1 Test Method Derivation

The preceding test method is derived from the Continuity test method in MIL-DTL-17.

4.5.8 Conductor and Shield Resistance

Electrical resistance shall be determined on conductors or shields, as applicable, as specified in the applicable specification sheet. Cables containing two or more component wires shall have conductor resistance measured on each conductor prior to cabling, unless otherwise specified. The test procedure shall be in accordance with ASTM B 193. All test results shall be corrected to 20°C, unless otherwise specified.

4.5.9 Dielectric Concentricity

The concentricity of the dielectric insulation shall be determined by first locating and recording the minimum wall thickness measured on a cross section of the dielectric insulation. The maximum wall thickness of this same cross section of dielectric shall also be measured and recorded. All wall thickness measurements shall be made under suitable magnification. The wall thickness shall be the shortest distance between the outer rim of the dielectric insulation and the outer rim of the underlying strand of the conductor. The ratio of the minimum wall thickness to the maximum wall thickness, multiplied by 100, shall define the percent concentricity.

4.5.9.1 Test Method Derivation

The preceding test method is derived from the Insulation Concentricity test method in AS22759.

4.5.10 Dielectric/Jacket Elongation and Tensile Strength

Specimens of the dielectric insulation or cable jacket, as applicable, shall be carefully removed and tested for elongation and tensile strength in accordance with AS4373, Method 705, using 1-inch (25-mm) bench marks, a 1-inch (25-mm) initial jaw separation, and a jaw separation speed of 2 inches (51 mm) per minute, unless otherwise specified in the applicable specification sheet.

4.5.11 Differential Impedance

This method is appropriate for determination of the characteristic impedance of differential pairs in cables used for applications such as Universal Serial Bus (USB) or IEEE 1394. Differential impedance shall be measured in accordance with EIA-364-108, Time Domain Method.

4.5.12 Dimensional Stability

4.5.12.1 Specimen Preparation

A 5-foot (1.5-m), minimum, specimen shall be cut. The ends of the specimen shall be cut squarely and the specimen formed into an 18-inch (457-mm) coil.

4.5.12.2 Procedure

Place the specimen in an air-circulating oven at the temperature specified in the applicable specification sheet and condition for 6 hours. After the conditioning period, remove the specimen from the oven and condition at room temperature for 4 hours. Measure both ends of the specimen for protrusion or contraction of the inner conductor.

4.5.12.3 Test Method

The preceding test method is derived from the Dimensional Stability test method in MIL-DTL-17.

4.5.13 Dimensions

Measurements shall be made on a 12-inch (305-mm), minimum, length of cable. Inner components shall be made accessible by stripping and removing the outer components carefully so as not to nick, cut, or otherwise damage the component to be measured. Four points for measurement shall be located 3 to 4 inches (76 to 102 mm) apart along the component or finished cable specimen length, as applicable. Measurements shall be made at each point at two approximately perpendicular planes or as required to assure that the minimum and maximum reading is attained at each point. A total of eight measurements shall be performed on each specimen. The minimum, maximum, and average values shall be recorded, as applicable. Measurements shall be made with a micrometer, caliper, or any other instrument of equal accuracy.

4.5.13.1 Test Method Derivation

The preceding test method is derived from the Diameter Measurements test method in MIL-DTL-17.

4.5.14 Examination of Product

All samples shall be examined carefully to determine conformance to this specification and to the applicable specification sheet with regard to requirements not covered by specific test methods.

4.5.15 Eye Pattern

Eye pattern shall be tested in accordance with the appropriate method described in the commercial standard written for the particular cable (i.e. USB 2.0, USB 3.0). The basis for the height and width of the opening that describes the pass/fail criteria may be contained in a customer specification.

4.5.16 FEXT

FEXT (far end crosstalk) shall be tested in accordance with the appropriate method described in the commercial standard written for the particular cable (i.e. USB 2.0, USB 3.0). For category cables requiring FEXT, the cable shall be tested in accordance with ASTM D 4566, Section 27.

4.5.17 Flammability

Flammability shall be tested in accordance with one of the following procedures as specified in the applicable specification sheet.

4.5.17.1 Flammability - Method A, Vertical Test, Inclined Burner (VW-1)

The test shall be performed in accordance with UL 1581, Section 1080.

4.5.17.2 Flammability - Method B, 60° Test, Inclined Burner

4.5.17.2.1 Test Apparatus

The test shall be performed within a test chamber approximately 1 foot (0.30 m) square by 2 feet (0.61 m) in height, open at the top and front to provide adequate ventilation for combustion but to prevent drafts. The specimen holder shall be so designed that the lower end of a 24-inch (610-mm) specimen is held by a clamp, while the upper end of the specimen passes over a pulley and can be suitably weighted to hold the specimen taut at an angle of 60 degrees with the horizontal, in a plane parallel to and approximately 6 inches (152 mm) from the back of the chamber. The test flame shall originate from a Bunsen type gas burner with a 0.250-inch (6.4-mm) inlet, a needle valve in the base for gas adjustment, a nominal bore of 0.375 inch (9.5 mm), and a barrel length of approximately 4 inches (102 mm) above the air inlets. The burner shall be adjusted to furnish a 3-inch (76-mm) high conical flame with an inner cone approximately 1 inch (25 mm) in length and a flame temperature not less than 954°C at its hottest point, as measured with an accurate thermocouple pyrometer. A sheet of facial tissue conforming to UU-T-450 shall be suspended taut and horizontal 9.5 inches (241 mm) below the point of application of the flame to the specimen and at least 0.50 inch (13 mm) from the chamber floor, so that any material dripping from the specimen shall fall upon the tissue.

4.5.17.2.2 Test Procedure

A 24-inch (610-mm) specimen shall be marked at a distance of 8 inches (203 mm) from its lower end to indicate the point for flame application and shall be placed in the specified 60-degree position in the test chamber. The lower end of the specimen shall be clamped in position in the specimen holder and the upper end shall be passed over the pulley of the holder and the appropriate weight shall be attached. Weight shall be sufficient to hold the specimen taut throughout the test. With the burner held perpendicular to the specimen and at an angle of 30 degrees from the vertical plane of the specimen (see Figure 2), the hottest portion of the flame shall be applied to the lower side of the specimen at the test mark. The period of test flame application shall be 30 seconds and the test flame shall be withdrawn immediately at the end of that period. The distance of flame travel upward along the specimen from the test mark and the time of burning after removal of the test flame shall be recorded; also the presence or absence of flame in the facial tissue due to incendiary dripping from the specimen. Charred holes or charred spots in the tissue shall be ignored in the absence of actual flame. Breaking of the specimen shall not be considered as failure, provided the requirements for flame travel limits, duration of flame, and the absence of incendiary dripping are met.

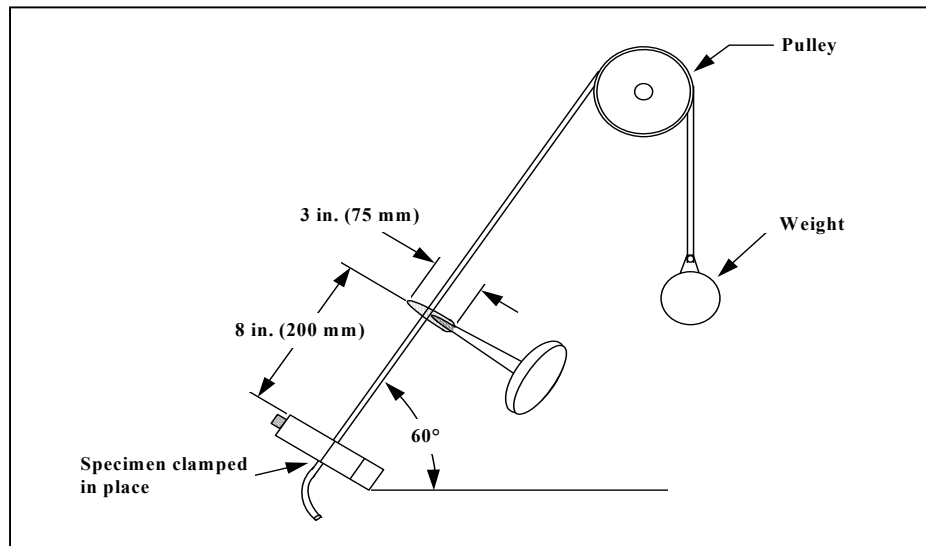

FIGURE 2.

Flammability, Test Apparatus - Method B, 60° Test, Inclined Burner

4.5.17.2.3 Test Method Derivation

The preceding test method conforms to FAR Part 25, Appendix F, Part I, and includes a provision for the detection of incendiary dripping.

4.5.17.3 Flammability - Method C, Horizontal Test, Vertical Burner

4.5.17.3.1 Apparatus

The test shall be performed within a test chamber approximately 14 inches (356 mm) square by 24 inches (610 mm) in height, open at the top and front to provide adequate ventilation for combustion but to prevent drafts. The chamber shall be equipped with supports 12 inches (305 mm) apart, designed to hold a 15-inch (381-mm) specimen in a taut, horizontal position during the test, and located in a plane parallel to and approximately 6 inches (152 mm) from the back of the chamber. The test flame shall originate from a Tirrill type gas burner with a 0.25-inch (6.4-mm) inlet, a needle valve in the base for gas adjustment, a nominal bore of 0.38 inch (9.5 mm) and a barrel length of approximately 4 inches (102 mm) above the air inlets. The burner shall be adjusted to furnish a 5-inch (127-mm) high conical flame with an inner cone approximately 1.5 inches (38 mm) in height.

4.5.17.3.2 Procedure

A 15-inch (381-mm) specimen shall be placed in a horizontal position in the chamber on supports 12 inches (305 mm) apart. Two strips of indicator paper shall be attached to the specimen 10 inches (254 mm) apart, each paper being 5 inches (127 mm) from the point on the specimen where the inner blue cone of the flame is to be applied. The indicator paper shall be moistened sufficiently for proper adhesion and wrapped once around the specimen, with the gummed side towards the specimen, and the ends pasted evenly together and projected 0.75 inch (19 mm) from the specimen on the opposite side to which the flame is to be applied. The Tirrill burner shall be placed in a vertical position and the flame adjusted to 5 inches (127 mm) in height with the inner blue cone 1.5 inches (38 mm) in height. The burner, in a vertical

position, shall be placed so that the inner cone just touches the underside of the specimen at a point midway between the two indicator papers. The flame shall be directed against the specimen for exactly 30 seconds and then removed. After flaming of the specimen has ceased, the indicator papers shall be examined to determine the maximum distance the flame extended in either direction from the center point of application of the flame.

4.5.17.3.3 Test Method Derivation

The preceding test method is derived from the Flame Retardance Horizontal test method of CSA Standard C22.2 No. 0.3.

4.5.17.4 Flammability - Method D, 45° Test, Inclined Burner

4.5.17.4.1 Apparatus

A gas burner having a 0.5-inch (13-mm) inlet, a nominal core of 0.4 inches (10 mm), and a length of 4 inches (102 mm) above the primary inlets shall be used. The gas burner shall be adjusted to produce a 4-inch (102-mm) gas flame with an inner cone one-half of its height.

4.5.17.4.2 Procedure

Suspend a 24-inch (610-mm) test specimen in a draft-free chamber such that the specimen is at a 45-degree angle to the vertical wall of the test chamber. The burner shall be perpendicular and in the plane of the specimen. The tip of the inner cone shall be positioned 4 inches (102 mm) from the bottom of the specimen. The flame shall be applied to the specimen for 15 seconds. The afterburn time shall be recorded.

4.5.17.4.3 Test Method Derivation

The preceding test method is derived from the Flame Resistance test method in SAE J1128.

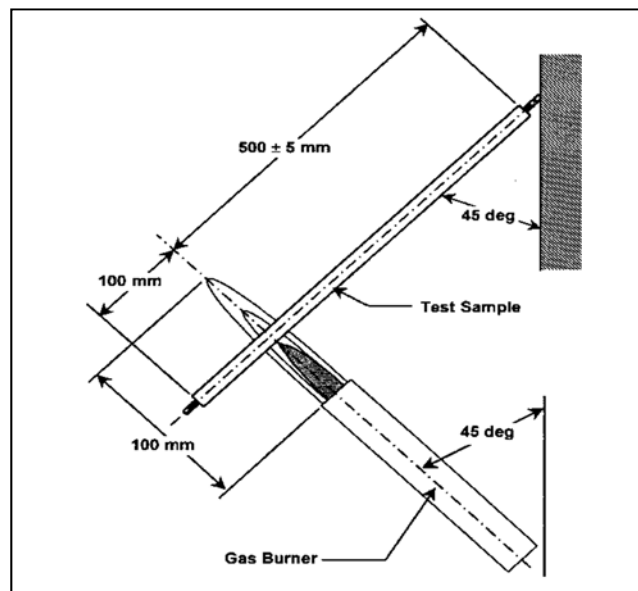

FIGURE 3.

Flammability, Test Apparatus - Method D, 45° Test, Inclined Burner

4.5.18 Heat Shock

A 4-inch (102-mm) specimen of finished cable shall be suspended for 4 hours in an air-circulating oven at the temperature specified in the applicable specification sheet. The velocity of air past the specimens shall not be less than 100 feet (30 m) per minute. After conditioning, the specimen shall be removed, cooled to room temperature, and visually examined for evidence of melting or flowing.

4.5.19 Insulation Resistance

Insulation resistance shall be measured on samples of finished cable at least 25 feet (7.6 m) in length. A DC potential between 200 and 500 volts shall be applied between each conductor or shield in the cable and all the other conductors and shields. The leakage current shall be measured after a 2-minute electrification period. However, a stable, or an increasing reading indicating compliance with the specification requirement obtained before the 2-minute period shall be acceptable. The insulation resistance of the test specimen shall be calculated from the following formula:

$$R = \frac{M \times L}{1000}$$

Where:

R = insulation resistance for 1000 feet (or 1 km) in megohms

M = reading in megohms

L = test specimen length, in feet (or meters), measured between outer conductor ends

4.5.19.1 Test Method Derivation

The preceding test method is derived from the Insulation Resistance test method in MIL-DTL-17.

4.5.20 Jacket Concentricity and Wall Thickness

The concentricity and wall thickness of the cable jacket shall be determined by first locating and recording the minimum wall thickness measured on a cross section of the jacket. The maximum wall thickness of this same cross section of jacket shall also be measured and recorded. The wall thickness shall be the radial distance between the inner and outer rim of the jacket as measured under suitable magnification. The ratio of the minimum wall thickness to the maximum wall thickness, multiplied by 100, shall define the percent concentricity.

4.5.20.1 Test Method Derivation

The preceding test method is derived from the Concentricity test method in WC 27500.

4.5.21 Jacket Flaws

One of the following methods shall be used to determine the presence of jacket flaws.

4.5.21.1 Impulse Test

Finished cable shall be tested in accordance with ASTM D 3032, Section 13, using the voltage specified in the applicable specification sheet with the shield grounded at one end or both ends. When specified in the contract or order, jacket failure, untested portions, or portions which have been exposed to fewer or more than the specified pulses may be marked by stripping the jacket or by any other suitable method of marking as specified in the contract in lieu of being cut out of the cable.

4.5.21.2 Spark Test

Finished cable shall be passed through a chain electrode spark test device using the voltage specified in the applicable specification sheet at a frequency of 60 or 3000 Hz. For specification sheets specifying a test frequency of 60 Hz only, 3000 Hz may be used alternatively. The shield shall be grounded at one or both ends. The electrode shall be of a suitable bead chain or fine mesh construction that will give intimate metallic contact with practically all of the cable surface. Electrode length and speed of specimen movement shall be such that the cable is subjected to the test voltage for a minimum of 0.2 second. Any portion showing jacket breakdown shall be cut out, including at least 2 inches (51 mm) of jacket on each side of the failure.

4.5.21.2.1 *Test Method Derivation*

The preceding test method is derived from the Jacket Flaws test method in WC 27500.

4.5.22 Low Temperature-Cold Bend

One end of a cable specimen shall be secured to a mandrel having a diameter as specified in the applicable specification sheet and placed in a cold chamber. One full turn shall be wrapped around the mandrel and the opposite end shall have sufficient weight attached to keep the cable vertical and tangent to the mandrel during the bending operation. The chamber shall be lowered to the temperature specified in the applicable specification sheet at a rate not to exceed 50°C per minute. The specimen and the mandrel shall be conditioned at this temperature for 4 hours. At the end of this period, and while both the specimen and mandrel are still at this low temperature, the cable shall be wrapped around the mandrel for 180 degrees without opening the chamber. The time for bending around 180 degrees of the mandrel shall be one-half minute at a uniform rate of speed. A revolving mandrel operated externally from the chamber shall be used. The specimen shall then be removed from the mandrel and visually examined, without magnification, for cracks. After examination of cracks, shielded and jacketed specimens shall then be subjected to the voltage withstand test (4.5.34.2).

4.5.22.1 Test Method Derivation

The preceding test method is derived from the Cold Bend test method in WC 27500.

4.5.23 NEXT

NEXT (near end crosstalk) shall be tested in accordance with the appropriate method described in the commercial standard written for the particular cable (i.e. USB 2.0, USB 3.0). For category cables requiring NEXT, the cable shall be tested in accordance with ASTM D 4566, Section 25.

4.5.24 Partial Discharge (Corona Extinction Voltage)

Partial discharge extinction voltage (PDEV) shall be defined for this test method as the voltage at which the apparent discharge level falls to 5 picocoulombs or less as the applied voltage is decreased from a value exceeding the inception voltage.

4.5.24.1 Specimen Preparation

A length of cable shall be selected such that the sensitivity of the detecting equipment will permit observation of discharges of 5 picocoulombs or less. The specimen shall be as shown in Figure 4. Similar preparation should be made on triaxial cables.

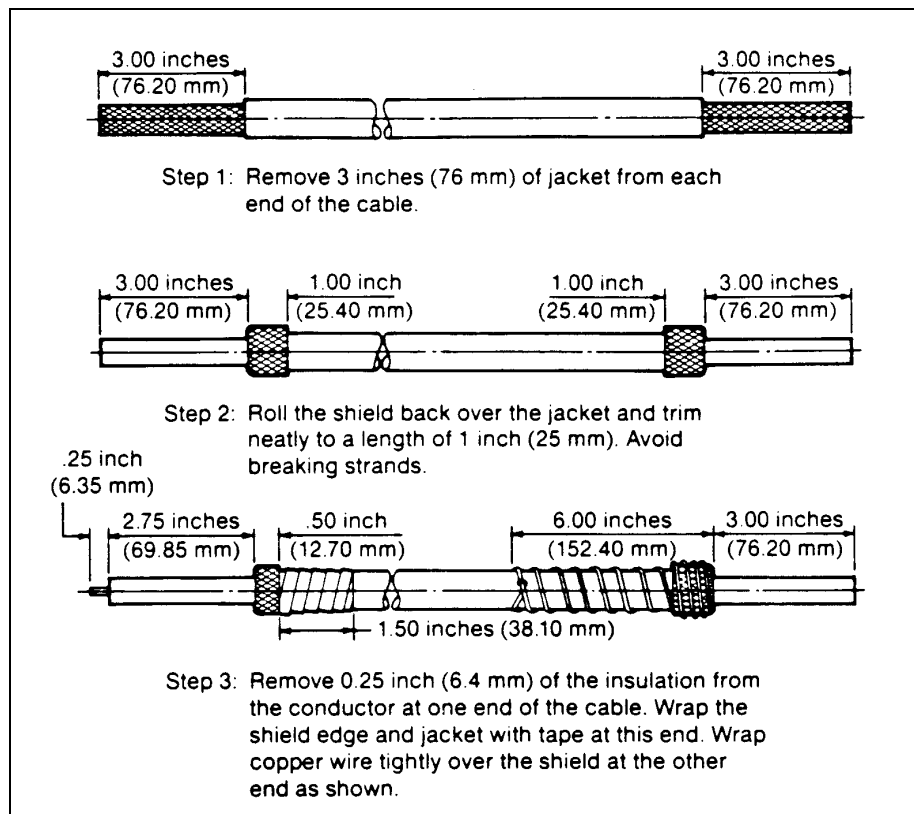

FIGURE 4.

Partial Discharge (Corona) Sample Preparation

4.5.24.2 Procedure

Connect the specimen to the voltage source so that the voltage is between the conductor and the shield. Triaxial cables shall be connected between the conductor and the first braid. In all cases, the high voltage shall be connected to the conductor or inner shield of the triaxial cable. The frequency of the test voltage shall be between 48 and 62 Hz. The specimen shall be connected to the detecting equipment with the specimen ends immersed in oil until the shield is at least 0.25 inch (6.4 mm) below the surface of the oil. Measurements shall not be made with air bubbles still visible in the oil. Apply the voltage at a maximum rate of 50 volts per second to specimens having a specified PDEV of 3 kV or less, and 100 volts per second for specimens having a specified PDEV above 3 kV. Increase the voltage until partial discharges are detected by the equipment. Then lower the voltage at the same rate until the partial discharges cease. This voltage shall be recorded as the PDEV.

4.5.24.3 Test Method Derivation

The preceding test is derived from the Corona Extinction Voltage test method in MIL-DTL-17.

4.5.25 Propagation Delay Skew

Propagation Delay Skew between pairs shall be calculated using the following formula:

$$\text{Propagation Delay Skew} = \left| \text{Propagation Delay (pair A)}_{\text{frequency n}} - \text{Propagation Delay (pair B)}_{\text{frequency n}} \right|$$

This calculation is to be made either over the frequency range specified in the applicable specification sheet or, if propagation delay is measured using the TDR method for a differential pair, it is a singular value. For multi-pair cables, propagation delay skew shall be calculated for all pair combinations excluding reciprocal combinations (i.e., "Pair A - Pair B" and "Pair B - Pair A" results in the same values and is thus not required).

4.5.26 Radiation Resistance

A 10-foot (3.0-m) specimen of finished cable shall be subjected to the electron radiation dosage as specified in the applicable specification sheet at an average rate of between 5 and 10 megarads (50 and 100 kGy) per minute. Following exposure, the center portion of the specimen shall be wound around a mandrel having a diameter as specified in the applicable specification sheet. The ends of the specimen shall extend at least 6 inches (152 mm) beyond the wound portion. Shielded and jacketed specimens shall then be removed from the mandrel without unwinding and shall be subjected to the voltage withstand test of 4.5.34.2. Unshielded, jacketed specimens shall be examined for cracks while still on the mandrel.

4.5.27 Shield Coverage

4.5.27.1 Braided Shields

The percent optical coverage (OC) of the braided shields shall be determined using the following formula:

$$OC = (2F - F^2) \times 100$$

Where:

$$F = \frac{EPd}{\sin \alpha} = \frac{ECd}{2L \sin \alpha}$$

Where:

- E = number of strands per carrier
- α = angle of strands with axis of cable
- P = picks per inch of cable length
- d = diameter of strands (or width, if flat strands are used)
- C = number of carriers
- L = length of lay of strands along cable

and

$$\tan \alpha = \frac{2\pi(D+2b)P}{C} = \frac{\pi(D+2b)}{L}$$

Where:

- b = diameter of strands (or thickness, if flat strands are used)
- D = average diameter of cable under shield (see 4.5.13)

4.5.27.2 Spiral Shields

The percent optical coverage (OC) of the spiral shield shall be determined using the following formula:

$$OC = F \times 100$$

Where:

$$F = \frac{Ed}{L \sin \alpha}$$

Where:

- E = number of strands
- d = diameter of strands
- L = length of lay of strands along the cable
- α = angle of strands with axis of cable

and

$$\tan \alpha = \frac{\pi(D+b)}{L}$$

Where:

- b = diameter of strands
- D = average diameter of cable under the shield (see 4.5.13)

4.5.27.3 Test Method Derivation

The preceding test methods are derived from the Shield Coverage test method in WC 27500.

4.5.28 Skew (Within Pair)

A sample of appropriate length shall be tested for skew in accordance with the equipment manufacturer's procedure. Skew shall be reported in nanoseconds per unit length at the frequency shown on the applicable specification sheet.

4.5.29 Structural Return Loss

4.5.29.1 Specimen Preparation

The specimen shall be of sufficient length to exhibit at least 3 dB attenuation at the lowest frequency required, unless otherwise specified. The specified connectors shall be attached to both ends of the specimen and the assembly connected to a TDR that is capable of producing a step-function rise-time of 150 picoseconds or less. With the far end of the specimen connected to a matched load, the impedance variation exhibited by each cable connector-cable interface shall not be greater than the maximum impedance variation permitted for the cable itself.

4.5.29.2 Procedure

An appropriate test set shall be used to measure the structural return loss of the sample. Calibration and specimen measurements shall be made in accordance with the analyzer or system procedures. The return loss shall be recorded over the specified frequency range.

4.5.29.3 Determination of Compliance

Within the frequency range(s) specified in the applicable specification sheet, the structural return loss shall be not greater than the specified value. (Note: Structural Return Loss is measured in dB. This measurement may be reported as SWR or VSWR and expressed as a ratio.)

4.5.29.4 Test Method Derivation

The preceding test method is derived from the Structural Return Loss test method in MIL-DTL-17.

4.5.30 Surface Transfer Impedance

4.5.30.1 Sample Preparation

Approximately 4 feet (1.2 m) of the cable shall be prepared in the manner described below. Any method of shield termination may be used provided the method is shown to produce results of equal accuracy to that obtained with the method described below.

4.5.30.1.1 *End A Preparation*

(See Figure 5). Approximately 3 inches (76 mm) of the cable jacket shall be removed from one end of the cable and the shield pushed back to expose the insulated conductor. The insulation shall be removed from the conductor to within 1 inch (25 mm) of the pushed-back shield as shown in Figure 5, Step 1. For a multi-conductor cable, connect all the conductors together to form a single "conductor". The shield shall then be pulled forward over the remaining insulation and soldered to the conductor. The shield shall completely enclose the insulated conductor, shall be soldered around 360 degrees of the conductor, and all disturbed

portions of the shield shall be well soldered. The conductor shall extend beyond the soldered joint with the shield and shall be formed and trimmed so as to be able to be soldered into the center pin of a BNC female-female adapter as shown in Figure 5, Step 2. Excess shield beyond the solder joint shall be removed, and the center pin of the adapter shall be attached to the conductor so that the pin is within 0.50 inch (13 mm) of the soldered joint. From the soldered joint, measure 1 meter and make an appropriate mark on the jacket insulation. A piece of shrink tubing or other appropriate material shall be applied over the soldered joint to insulate the joint as shown in Figure 5, Step 3. The adapter pin shall then be inserted into the BNC adapter as shown in Figure 5, Step 4. A metallic outer braid shall be pulled over the entire length of cable and shall extend one-third over the BNC adapter. The outer braid shall then be soldered to the BNC adapter, making sure that a 360-degree solder joint is formed as shown in Figure 5, Step 5.

4.5.30.1.2 End B Preparation

(See Figure 6). At the other end of the cable, push back the outer braid over the cable to expose the mark made 1 meter from the end "A" conductor solder joint. At the mark, the cable jacket shall be window-stripped for a distance of 0.50 inch (13 mm), 0.25 inch (6.4 mm) on either side of the mark as shown in Figure 6, Step 1. The outer shield shall then be pulled taut back over the cable and twisted at the end of the cable to hold the outer braid in place. The outer braid shall be soldered to the underlying exposed shield for 360-degrees around the cable at the window cut. Excess outer braid between the solder joint and the end of the cable shall be removed as shown in Figure 6, Step 2. Shrink tubing shall be applied over the entire length of outer braid ensuring that the braid is pressed firmly to the jacket as shown in Figure 5, Step 6. Excess heat shrink tubing shall be removed. The end of the cable shall then be cut and prepared for termination to the N-male connector such that the distance from the installed connector to the window in the cable jacket is as close as possible as shown in Figure 6, Step 3 and Figure 6, Step 4. For multi-conductor cables, one conductor shall be prepared for termination to the N connector, the other conductors shall be floating. (Floating conductors in a multi-conductor cable is achieved by applying shrink tubing to the exposed ends of the unused conductors.)

4.5.30.2 Configuration

An appropriate test set shall be used to measure the surface transfer impedance of the sample.

4.5.30.3 Procedure

This measurement procedure is suitable for use with a spectrum analyzer and tracking generator. The measurement procedure may be modified as needed if other instruments are used, provided the results are shown to be of equal accuracy to those obtained when the measurements are performed as described below. With the measuring system configured as shown in Figure 7, adjust the output of the signal generator to produce a trace on the spectrum analyzer, which at its highest point is near the top graticule line on the screen. Remove the specimen and insert a calibrated variable attenuator in its place. Adjust the attenuator until a trace is obtained which approximates the top graticule on the screen. The position of the trace shall be recorded either by storage on the screen or in any other suitable manner. Designate this trace A_0 , where A_0 is the setting of the attenuator in dB. Increase the attenuator setting by 20 dB and record the position of this trace, designated A_{20} , where A_{20} is the setting of the attenuator in dB. Increase the attenuator further by 20 dB and record the position of a trace designated A_{40} . Continue in this manner until the calibration traces have covered the entire height of the screen. Remove the attenuator and reconnect the specimen as shown in Figure 7.

Designate the resulting trace on the screen as S and record its position. The value of S, at any frequency, shall then be calculated using the following equation:

$$S = A_u + 20 \frac{y}{h} dB/m$$

Where:

A_u = attenuator setting used to produce the calibration trace immediately above trace S

y = distance on the screen between the traces A_u and S

h = distance on the screen between trace A_u and the calibration trace immediately below trace S

The power of attenuation P of the shield is:

$$P = 10^{S/10}$$

The surface transfer impedance Z_t , at the frequency chosen, is given by:

$$Z_t = \frac{Z_0}{2} \sqrt{P} \text{ ohms / meter}$$

Where:

Z_0 = characteristic impedance of the spectrum analyzer and tracking generator

Unless otherwise specified, 100 points uniformly spaced throughout the decade of frequency, and including the beginning and end of the decade, shall be taken for each decade of frequency range specified in the applicable specification sheet.

4.5.30.4 Determination of Compliance

The values of Z_t , as determined from measurements made in accordance with 4.5.30.3, shall not exceed the maximum specified values of Z_t as shown in the applicable specification sheet in any of the following ways:

- A single maximum value of Z_t may be specified at a discrete frequency or over a range of frequencies.
- The maximum value of Z_t over a range of frequencies may be specified by a plot of the maximum value of Z_t versus frequency.
- The maximum value of Z_t over a range of frequencies specified by a curve defined by the maximum value of Z_t at given frequencies.
- The maximum value of Z_t over a range of frequencies may be specified from the following equation:

$$\text{Maximum specified } Z_t = A_{z(f)} B_z \text{ milliohms/meter}$$

Where:

f = frequency in MHz

A_z, B_z = Z_t calculation parameters specified in the applicable specification sheet

4.5.30.5 Test Method Derivation

The preceding test method is derived from the Surface Transfer Impedance test method in WC 61.

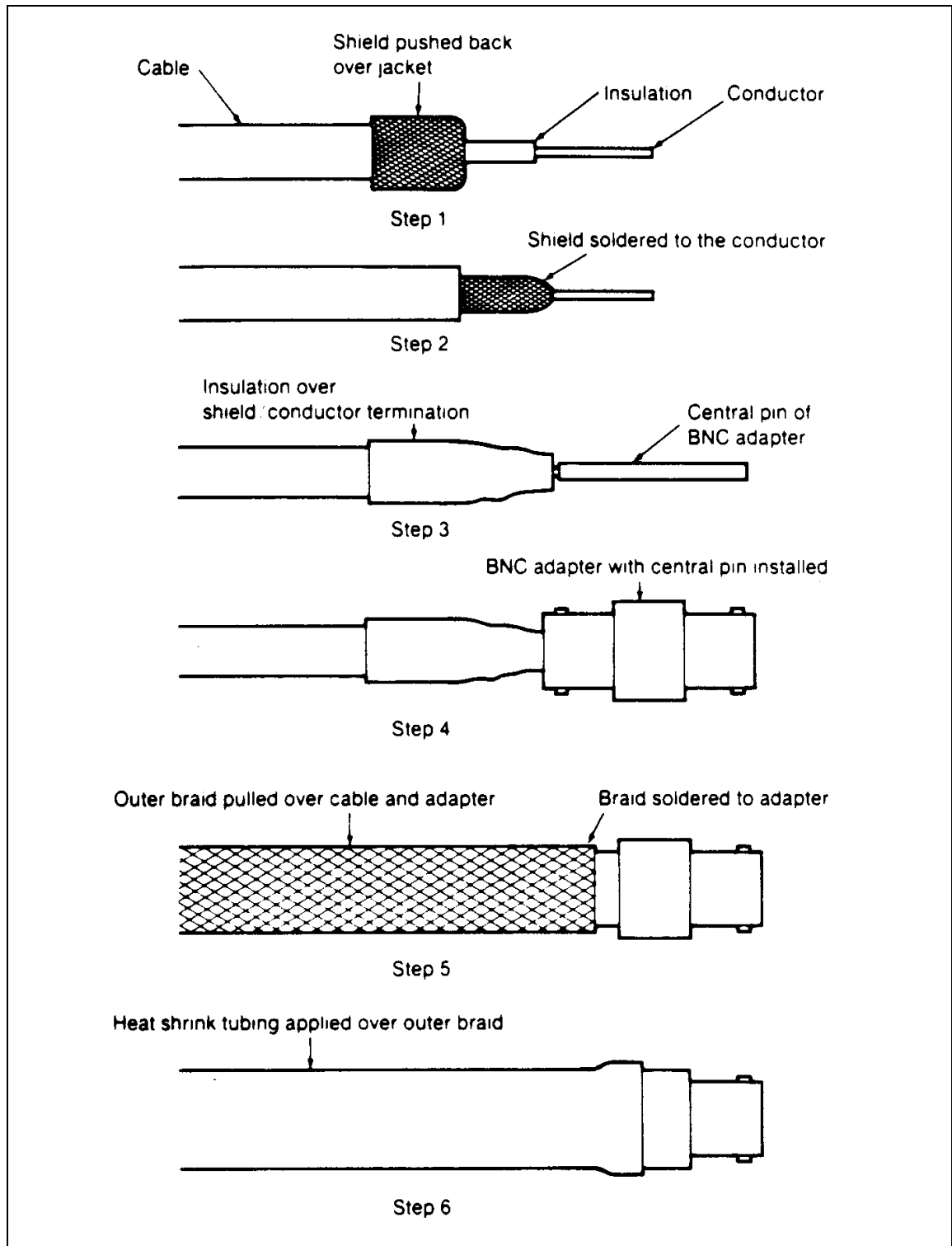

FIGURE 5.

Preparation of Cable End A

NOTE: ANY PRINTED COPY OF THIS DOCUMENT IS AN UNCONTROLLED COPY.

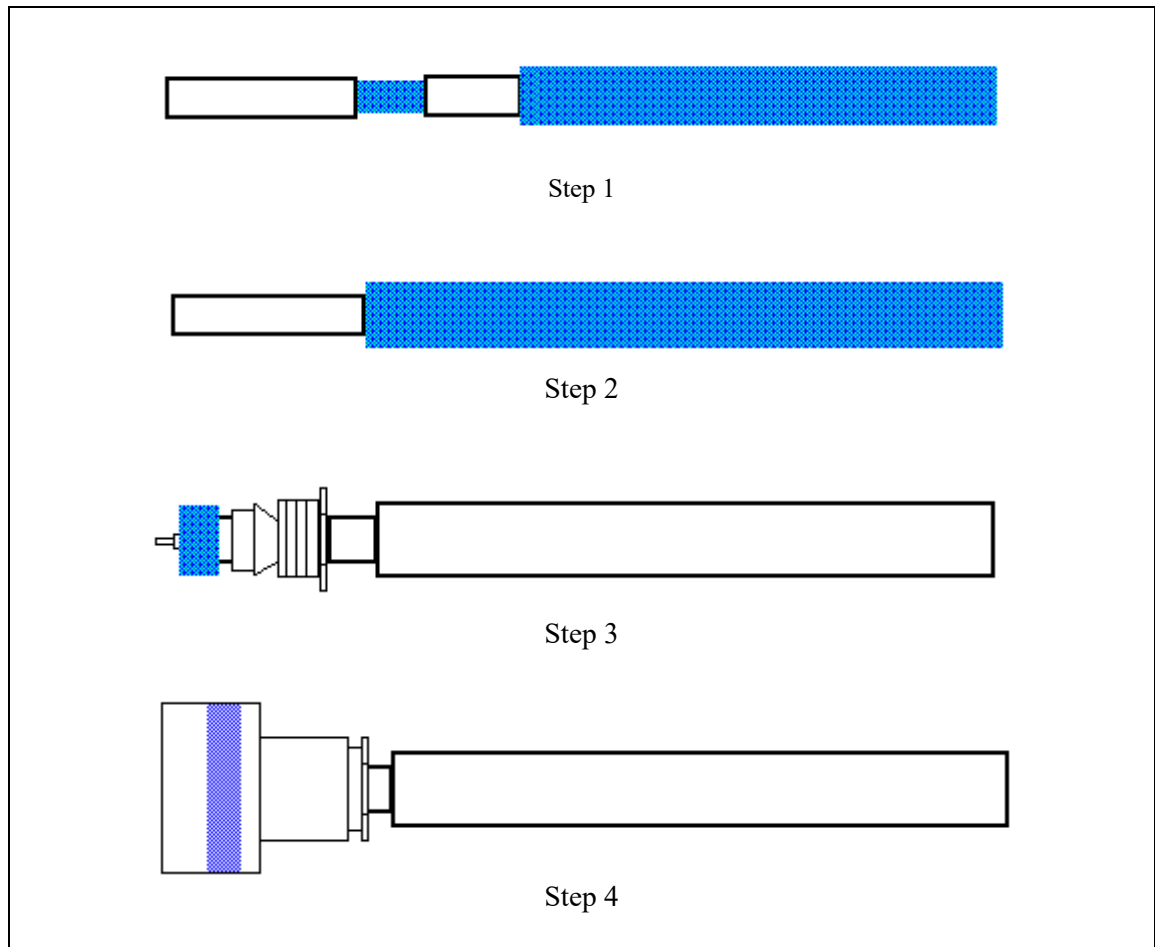

FIGURE 6.

Preparation of Cable End B

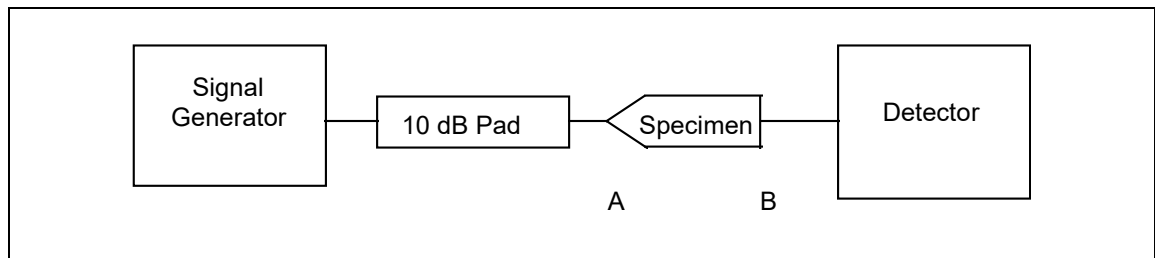

FIGURE 7.

Configuration of the measurement system for determining surface transfer impedance. The letters "A" and "B" refer to the A and B ends of the specimen as described in paragraph 4.5.30.1.

NOTE: ANY PRINTED COPY OF THIS DOCUMENT IS AN UNCONTROLLED COPY.

4.5.31 Time Delay

Time delay (TD), in nanoseconds per foot, shall be determined from the following formula:

$$TD = \frac{101.67}{V_p(\%)}$$

Where:

V_p = velocity of propagation as determined by ASTM D 4566.

4.5.32 Vacuum Stability

Specimens of finished cable shall be tested in accordance with ASTM E 595.

4.5.33 Velocity of Propagation

The following procedure is applicable to coaxial, twinaxial, and triaxial cables. For constructions that require Velocity of Propagation at a specific frequency or over a frequency range, testing shall be performed in accordance with ASTM D 4566, section 46.

4.5.33.1 Specimen Preparation

The sample cable shall be of suitable length, 10 feet (3 m), minimum. At one end of the cable, the center conductor and shield shall be connected together. For a twisted pair, the conductors shall be twisted together and the shield left unconnected. At the other end of the cable, one conductor shall be designated as the center conductor and the other conductor as the outer conductor. The sample length shall be defined as the length of cable covered by the shield. For an unshielded twisted pair, tape the components together 0.50 inch (13 mm) from each end of the cable. The sample length shall be defined as the length of cable between the outside edges of the tape. The sample length shall be measured and designated as L.

4.5.33.2 Procedure

The free end of the cable shall be attached to a "T"-type connector. One leg of the T shall be attached to a detector and the other leg to a signal generator. The signal generator shall be adjusted to a frequency of 1 MHz and the frequency shall then be increased until a sharp decrease in the detector reading is observed. The frequency generator shall be adjusted until a minimum in the detector reading is achieved. This frequency shall be recorded to the nearest 0.1 MHz. Designate this reading as f_1 . The frequency of the signal generator shall be increased further until another decrease in the detector reading is observed. The frequency of the minimum detector reading shall be recorded as f_2 . This procedure shall be repeated until at least four different frequencies are recorded.

4.5.33.3 Calculations

At each recorded frequency, the frequency in MHz shall be divided by the subscript number and the results recorded.

$$\begin{aligned} f_1 / 1 &= f_{01} \\ f_2 / 2 &= f_{02} \\ f_3 / 3 &= f_{03} \\ f_4 / 4 &= f_{04} \\ &etc. \end{aligned}$$

The mean value of all the resulting frequencies shall be calculated and designated as f . The velocity of propagation (V_p) shall be determined from the following formula:

$$V_p = \frac{2L_m f}{299.8} \quad \text{or} \quad \frac{2L_f f}{983.6} \quad \%$$

Where:

L_m = Specimen length in meters

L_f = Specimen length in feet

4.5.33.4 Test Method Derivation

The preceding test method is derived from the Time Delay test method in MIL-DTL-17.

4.5.34 Voltage Withstand

Voltage withstand tests shall be made using an AC source with a frequency of 50 or 60 Hz. The voltage specified in the applicable specification sheet shall be applied for 1 minute.

4.5.34.1 Voltage Withstand (Dielectric)

Voltage withstand (dielectric) tests shall be performed upon finished cable by applying the specified voltage between each conductor or shield in turn, and all other conductors and shields which shall be tied together and grounded. There shall be no dielectric breakdown.

4.5.34.2 Voltage Withstand (Post Environmental)

Voltage withstand (post environmental) tests on the outer jacket shall be performed after the specified conditioning. The finished cable shall be immersed in a 5-percent, by weight, solution of sodium chloride in water at room temperature for at least 1 hour and, while the cable is still immersed, a voltage of 1000 volts (rms) shall be applied between all the conductors and shields, tied together, and the water bath which shall be grounded.

4.5.34.3 Test Method Derivation

The preceding test methods are derived from the Dielectric Withstand and Voltage Withstand, Jacket, test methods in WC 27500.

4.5.35 Weight

The weight of each lot of finished cable shall be determined by Procedure I (4.5.35.1). Lots failing to meet the weight requirement of the applicable specification sheet when tested in accordance with Procedure I shall be subjected to Procedure II (4.5.35.2). All spools or reels failing to meet the requirements of the applicable specification sheet when tested to Procedure II shall be rejected.

4.5.35.1 Procedure I

A length of cable, sufficient to produce a measured weight to at least 3 significant figures, shall be weighed and converted to the weight per unit length shown on the applicable specification sheet.

4.5.35.2 Procedure II

The net weight of the finished cable on each spool or reel shall be obtained by subtracting the tare weight of the spool or reel from the gross weight of the spool or reel containing the finished cable. The net weight of cable on each spool or reel shall be divided by the accurately determined length of finished cable on that spool or reel and the resultant figure converted to the weight per unit length shown on the applicable specification sheet. When wood or other moisture absorbent materials are used for spool or reel construction, weight determinations shall be made under substantially uniform conditions of relative humidity.

4.5.35.3 Test Method Derivation

The preceding test methods are derived from the Wire Weight test methods in AS22759.

4.5.36 Weight Loss

A 5-foot (1.5-m) length of shielded cable shall be flush cut and weighed to the nearest 0.001 grams. Prior to weighing, the jacket surface of cables with jackets may be wiped clean with a suitable low boiling solvent such as isopropyl alcohol to remove any accumulation of debris. If a wipe is performed, the test specimen should be allowed to re-equilibrate to ambient conditions for 30 minutes. After cleaning, the sample should be handled using cotton gloves to avoid any contamination with finger oils. The cable jacket, if any, shall be removed by longitudinally slitting with a razor blade or a similar tool. After removal, the jacket and shielded inner bundle shall be wrapped into a loose coil and suspended in a forced air flow oven at $250 \pm 2^\circ\text{C}$ for 20 minutes. After this conditioning, the collective test specimen shall be allowed to cool to ambient conditions for 30 minutes and then reweighed to the nearest 0.001 grams. The percent weight loss shall be calculated using the following formula:

$$\% \text{ Weight Loss} = \frac{(\text{Original Weight} - \text{Final Weight})}{\text{Original Weight}} \times 100$$

4.5.37 Wrap Coverage

The coverage of a tape wrap shall be expressed as the percentage by which one turn of the tape overlaps the previous turn, and shall be determined using the following formula:

$$\text{Overlap} = \frac{a}{b} \times 100\%$$

Where:

a = distance, measured perpendicular to the edge of the tape, by which one turn of the tape overlaps the next

b = width of the tape

Alternatively:

$$\text{Overlap} = \left(1 - \frac{c}{d}\right) \times 100\%$$

Where:

c = distance between adjacent visible tape edges measured along the axis of the cable

d = width of the tape measured along the axis of the cable

5. STANDARD PACKAGING

Unless otherwise specified (see 6.1), the following shall define the standard spooling and labeling requirements for cable furnished under this specification. Standard shipping tolerance on ordered quantity shall be ± 10 percent.

5.1 SPOOLING REQUIREMENTS

All layers of cable shall be wound on spools or reels (see 5.1.1) with sufficient tension to prevent shifting of layers and creation of crossovers within layers. Finished cable lengths shall be wound on spools or reels with all ends exposed. There shall be no more than 5 lengths per spool or reel and no length shall be less than 50 feet (15 m).

5.1.1 Spools and Reels

Spools and reels shall be of a non-returnable type. Each spool and reel shall have an appropriate diameter for the respective cable size. In no case shall the barrel of the spool or reel have a diameter less than 3.5 inches (89 mm). Spools and reels shall be suitably finished to prevent corrosion under typical storage and handling conditions. Loaded plastic spools shall not exceed 50 pounds (23 kg). Loaded wooden reels shall have no weight restriction.

5.1.2 Containers

Unless otherwise specified (see 6.1), finished cable shall be delivered in standard commercial containers so constructed as to ensure acceptance by common or other carrier for safe transportation at the lowest rate to the point of delivery.

5.2 LABELING REQUIREMENTS

All spools and reels shall be identified with the following information:

Manufacturer's Part Number
Lot Number
Quantity in Feet (*or Meters*)
Name of Manufacturer

6. NOTES

6.1 ORDERING DATA

Procurement documents should specify the following:

- a. Title, number, and revision of this specification
- b. Applicable specification sheet part number
- c. Quantity
- d. Special preparation for delivery requirements, if applicable (see Section 5)

6.2 METRIC UNITS

Metric units (where shown in parentheses) are for information only.

6.3 TEST METHOD DERIVATIONS

Test method derivations contained in test methods are shown for information only.

6.4 TRADEMARKS

Raychem, TE Connectivity, and TE connectivity (logo) are trademarks.

6.5 SYMBOLS

The following symbols and prefixes are used in this specification and are listed below for information.

6.5.1 Standard Prefixes

Symbol	Prefix	Multiplier
M	mega	10^6
k	kilo	10^3
d	deci	10^{-1}
c	centi	10^{-2}
m	milli	10^{-3}
μ	micro	10^{-6}
n	nano	10^{-9}
p	pico	10^{-12}
f	femto	10^{-15}

6.5.2 Standard Symbols

Symbol	Name
B	bel
Bm	bel (relative to 1 milliwatt)
C	coulomb
$^{\circ}\text{C}$	degrees, Celsius
$^{\circ}\text{F}$	degrees, Fahrenheit
eV	electron-volt
ft.	foot
F	farad
g	gram
Hz	hertz
in.	inch
m	meter
psi	pounds per square inch
s	second
V	volt
Ω	ohm

6.5.3 Electrical Symbols

Symbol	Description
a_1, a_2	Attenuation formula coefficients
ac	Alternating current
A_0, A_{20}, \dots	Calibrated attenuator settings, dB
$A(f)$	Attenuation at frequency (f)
A_u	Calibrated attenuator setting, dB
A_z	Z_t calculation parameter
B_z	Z_t calculation parameter
C	Calculated or measured capacitance
C_a, C_b, C_c, C_d	Measured capacitances
C_{ag}, C_{bg}	Measured capacitance, conductor to ground
C_{ap}, C_{bp}	Measured capacitance, conductor to pair
C_m	Mutual capacitance, calculated
C_u	Capacitance unbalance, calculated
$C_{u1}, C_{u2}, \text{etc.}$	Capacitance unbalance, %
C_{uL}	Pair-to-pair capacitance unbalance, measured
C_{upg}	Pair-to-ground capacitance unbalance, calculated
CRAL	Calibrated reference air line
dc	Direct current
f	Frequency (MHz)
f_1, f_2, \dots	Resonant frequency (MHz)
h	Measurement on spectrum analyzer screen
L	Calculated or measured inductance
M	Leakage current reading in megohms
P	Power ratio
PDEV	Partial discharge extinction voltage
R	Insulation resistance, calculated
S	Calculated attenuation
SWR	Standing wave ratio
TD	Time delay
TDR	Time domain reflectometer
VSWR	Voltage standing wave ratio
V_p	Velocity of propagation, %
y	Measurement on spectrum analyzer screen
Y	Pair-to-ground capacitance unbalance, measured
Y_1	Pair-to-ground capacitance unbalance per 1000 feet (<i>km</i>)
Z_{in}	Input impedance
Z_o	Characteristic impedance
Z_{os}	Open circuit impedance, measured
Z_{sc}	Short circuit impedance, measured
Z_{ref}	Reference characteristic impedance
Z_t	Surface transfer impedance
ρ	Reflection coefficient, calculated
ρ_u	Reflection coefficient, un-scaled

Looking for pricing, stock, or lifecycle information?

Click below to explore more details on WIN SOURCE:

 [View 0026A0024-9X](#) on WIN SOURCE

 [TE Connectivity](#) Information

Optimize Your Supply Chain with WIN SOURCE Solutions

-  Global Sourcing Solution
-  Obsolete Management
-  Cost Control Management
-  Shortage Management
-  Alternative Solution
-  Excess Inventory Management