



THE DATASHEET OF
106529-2



NOTE



All numerical values are in metric units [with U.S. customary units in brackets]. Dimensions are in millimeters [and inches]. Unless otherwise specified, dimensions have a tolerance of ± 0.13 [$\pm .005$] and angles have a tolerance of $\pm 2^\circ$. Figures and illustrations are for identification only and are not drawn to scale.

1. INTRODUCTION

This specification covers the requirements for application of AMP-DUAC Headers and Connectors. This product line consist of contacts which are installed in 2- through 24-position plug and receptacle connector housings. These housings may mate with each other for wire-to-wire applications. The receptacle housing mates with printed circuit (pc) board right-angle or vertical header assemblies. The plug housings may be free hanging or panel mounted. The header assemblies come with pre-loaded contacts, and may be installed on the pc board manually, or automatically using robotic equipment. The contacts will accept 26-22, 22-18, and 16 AWG wire.

When corresponding with TE Personnel, use the terminology provided on this specification to help facilitate your inquiry for information. Basic terms and features of components are provided in Figure 1.

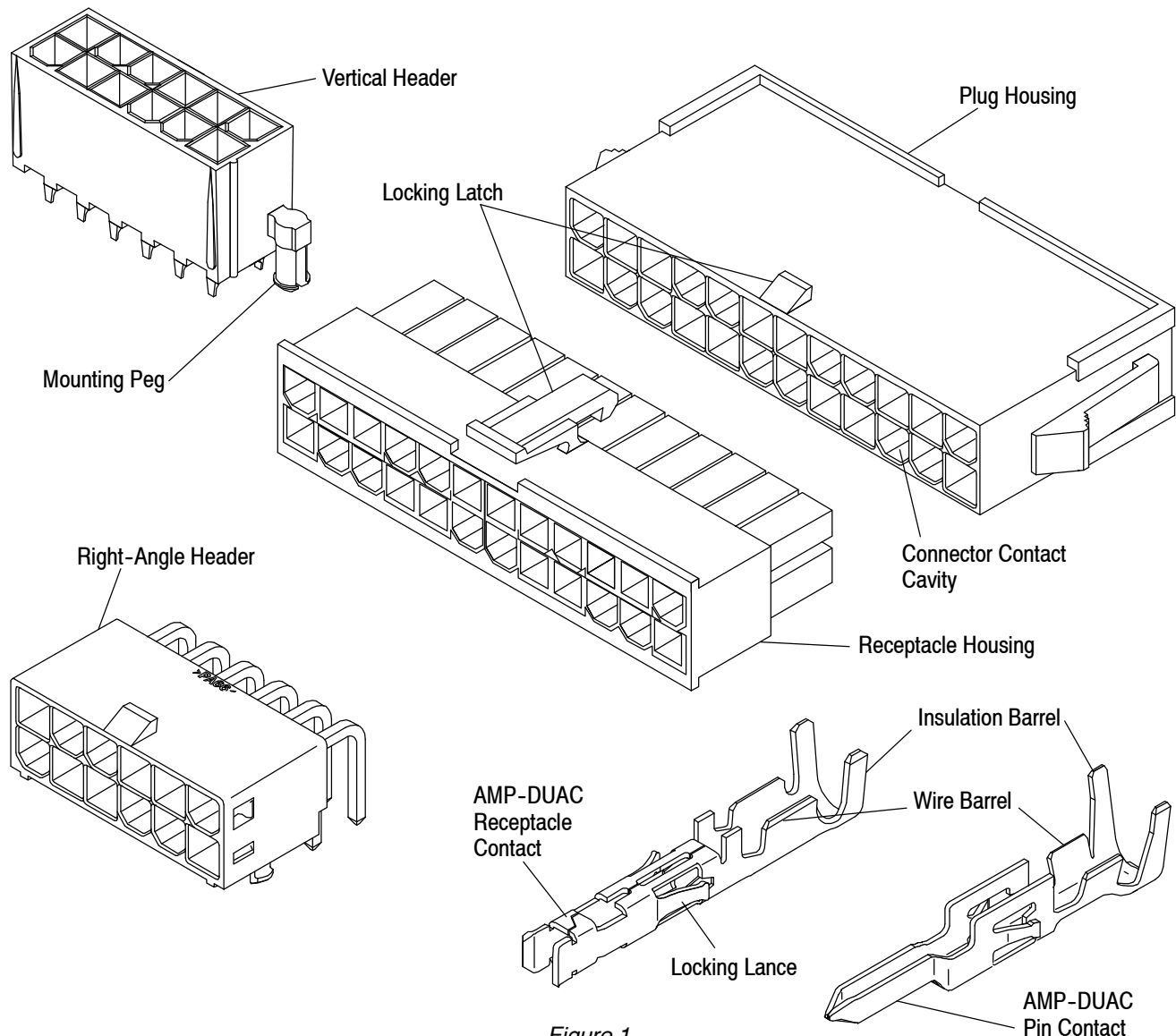

Figure 1

2. REFERENCE MATERIAL

2.1. Revision Summary

This paragraph is reserved for a revision summary covering the most recent additions and changes made to this specification which include the following:

- Updated document to corporate requirements
- Updated Figure 9

2.2. Customer Assistance

Reference Part Number 106527 and Product Code 2373 are representative numbers of AMP-DUAC Headers and Connectors. Use of these numbers will identify the product line and expedite your inquiries through a service network established to help you obtain product and tooling information. Such information can be obtained through a local TE Representative or, after purchase, by calling the Tooling Assistance Center or the Product Information number at the bottom of page 1.

2.3. Drawings

Customer Drawings for specific products are available from the service network. The information contained in Customer Drawings takes priority if there is a conflict with this specification or with any technical documentation supplied by Tyco Electronics.

2.4. Manuals

Manual 402-40 is available upon request and can be used as a guide in soldering. This manual provides information on various flux types and characteristics along with the commercial designation and flux removal procedures. A checklist is included in the manual as a guide for information on soldering problems.

2.5. Specifications

Product Specifications 108-1699 and 108-19099 provides product performance requirements and test information.

2.6. Instructional Material

The following list includes available instruction sheets (408-series) that provide assembly procedures for product, operation, maintenance and repair of tooling, as well as setup and operation procedures of applicators; and customer manuals (409-series) that provides setup, operation, and maintenance of machines.

<u>Document Number</u>	<u>Document Title</u>
408-3295	Preparing Reel of Contacts for Applicator Tooling
408-4385	Hand Crimping Tool 90714-1
408-8040	Heavy Duty Miniature Quick-Change Applicators (Side-Feed Type)
408-8053	Conversion Guide for Miniature Quick Change Applicators
408-8330	AMP-DUAC 6-Position Strain Relief 1375618-1
408-9816	Handling of Reeled Products
409-5128	Basic AMP-O-LECTRIC* Model "K" Terminating Machine 565435-5
409-5842	AMP-O-LECTRIC Model "G" Terminating Machine 354500-[]
409-5852	AMPOMATOR* CLS III-G Lead Making Machine 122500-[]
409-5878	AMPOMATOR CLS IV+ Lead-Making Machine 356500-[]
409-10012	AMP-O-MATIC* Side Feed Stripper-Crimper III Machine No. 1320895-[]

3. REQUIREMENTS

3.1. Storage

A. Ultraviolet Light

Prolonged exposure to ultraviolet light may deteriorate the chemical composition used in the header assemblies or housings.

B. Shelf Life

The header assemblies and housings should remain in the shipping containers until ready for use to prevent damage. These products should be used on a first in, first out basis to avoid storage contamination.

C. Reeled Contacts

When using reeled contacts, store coil wound reels horizontally and traverse wound reels vertically.

D. Chemical Exposure

Do not store housings or header assemblies near any chemicals listed below, as they may cause stress corrosion cracking in the components.

Alkalies	Ammonia	Citrates	Phosphates	Citrates	Sulfur Compounds
Amines	Carbonates	Nitrites	Sulfur Nitrites		Tartrates

NOTE  Where the above environmental conditions exist, phosphor-bronze contacts are recommended instead of brass if available.

3.2. Special Characteristics

AMP-DUAC Connectors are available as a wire-to-board or wire-to-wire connector system designed for power applications. The housings and header assemblies are designed on 4.2 x 4.2 mm centerlines. The housings are polarized to prevent miss-mating. The vertical headers are available with or without mounting pegs and drain holes.

3.3. Wire Selection and Preparation

The contacts will accept a wire size range of 26-22 and 22-18 AWG, and are to be terminated to stranded wire. Figure 2 lists the insulation diameter range, strip length, and crimp height as determined by the wire size.

CAUTION  When stripping the wire, care must be taken to avoid scraping, nicking, or cutting the conductor. Care must also be used when handling the wire during stripping and crimping to prevent cracking or breaking of the conductor and insulation.

NOTE  Each crimp dimension represents the functional range of a wire/contact combination. There are tool designs available to meet various application requirements. The developed crimp configuration is unique for each tool design and is acceptable provided the crimp height is within the functional range. For crimp dimensions of a specific tool, refer to instruction sheet packaged with manual tools and applicator log packaged with power tools.

Note: Not to Scale

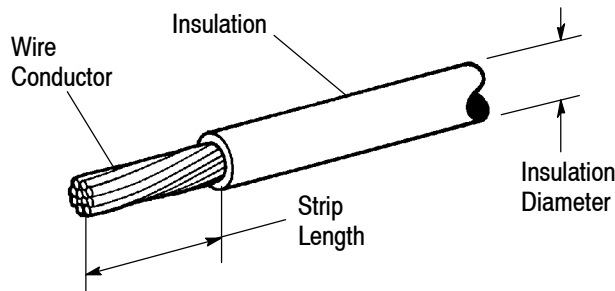

WIRE SIZE, mm ² [AWG]	INSULATION DIAMETER RANGE	WIRE STRIP LENGTH	WIRE BARREL CRIMP HEIGHT
0.12 [26]	1.20-1.75	2.4-3.2	0.690-0.590
[24]	1.20-1.75	2.4-3.2	0.740-0.640
0.30 [22]	1.20-1.75	2.4-3.2	0.840-0.740
0.35 [22]	1.50-2.40	2.4-3.2	0.860-0.760
[20]	1.50-2.40	2.4-3.2	0.960-0.860
0.87 [18]	1.50-2.40	2.4-3.2	1.120-1.020
(2) 0.8-0.9 [18]	3.30 Max	2.4-3.2	1.325-1.275
(1) [16]	3.00 Max	2.4-3.2	1.220-1.170

Figure 2

3.4. Crimped Contact Requirements

The contact shall be located in desired tooling and crimped according to the instructions packaged with that tooling, if available. See Section 5, TOOLING, of this document for details on tooling options and instructional materials.



Wire insulation shall NOT be cut or broken during the crimping operation, nor shall the insulation be crimped into the contact wire barrel. Reasonable care should be taken by tooling operators to provide undamaged wire terminations.

A. Contact Crimp Features

Figure 3 shows a typical contact as it should appear after crimping.

1. Crimp Location

For optimum crimp effectiveness, the crimp must be within the area shown and must meet the crimp requirements provided in Figure 3.

2. Crimp Height

The crimp applied to the wire barrel portion of the contact is the most compressed area and is most critical in ensuring optimum electrical and mechanical performance of the terminated contact. The contact wire barrel crimp height must be within the dimension provided in Figure 2.

3. Effective Crimp Length

Effective crimp length shall be defined as that portion of the wire barrel, excluding bellmouth(s), fully formed by the crimping tool. See Figure 3.

4. Conductor Extension

The conductor may extend beyond the wire barrel to the maximum shown in Figure 3.

5. Wire Barrel Seam

The wire barrel seam must be closed with no evidence of loose wire strands visible in the seam.

6. Conductor/Insulation

The conductor and insulation must both be visible in the area between the insulation barrel and the wire barrel.

7. Bellmouth

The front and rear bellmouths are caused by the extrusion of metal during crimping and must be within the range specified in Figure 3.

8. Cutoff Tab and Burr

The cutoff tab and burr resulting from the contact being cut from the carrier strip must be within limits to allow the contact to be fully inserted and seated in the housing. See Figure 3.

9. Flash

The wire barrel flash at the bottom of the wire barrel results from applied crimp pressure and must be within the dimension provided in Section X-X of Figure 3.

NOTE: Receptacle contact shown, but pin contact dimensions are the same.

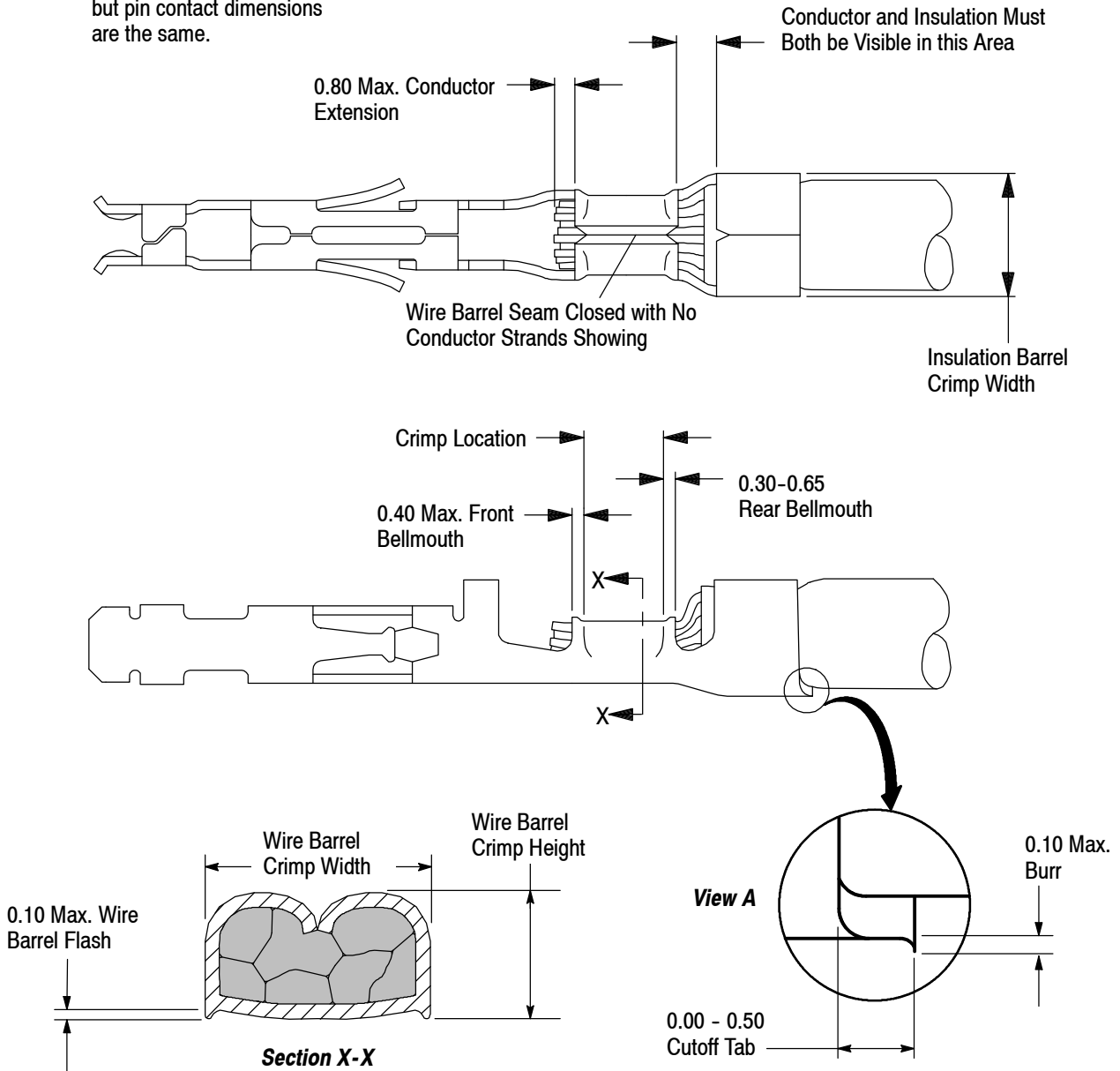

Figure 3

B. Twist and Roll

There shall be no twist, roll, deformation, or other damage to the mating portion of the crimped contact that will prevent proper mating. See Figure 4.

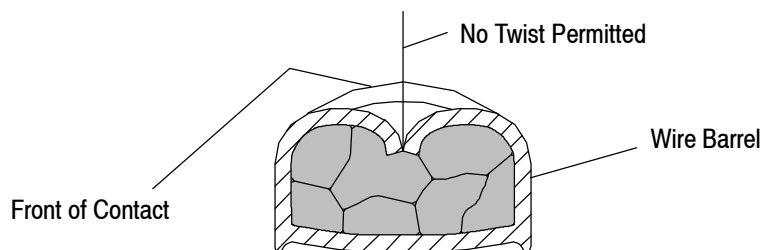

Figure 4

C. Straightness

The force applied during crimping may cause some bending between the crimped wire barrel and the mating portion of the contact. Such deformation is acceptable within the following limits.

1. Up and Down

The crimped contact, including cutoff tab and burr, shall not be bent above or below the datum line more than the amount shown in Figure 5.

2. Side to Side

The side-to-side bending of the contact may not exceed the limits provided in Figure 5.

NOTE

Periodic inspections must be made to ensure crimped contact formation is consistent as referenced.

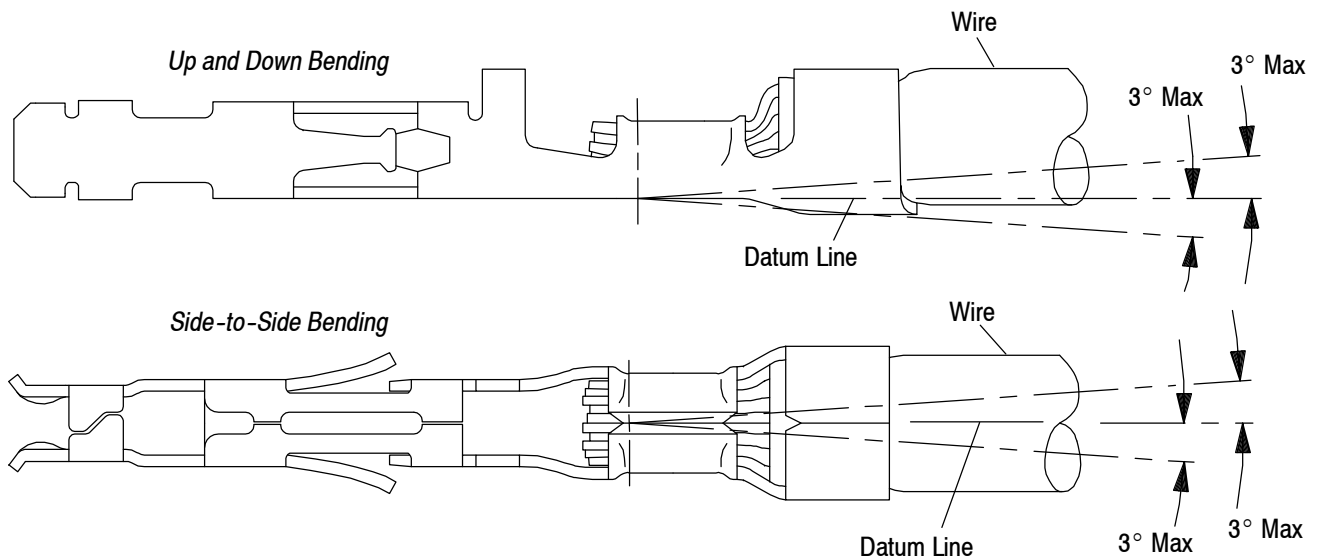

Figure 5

3.5. Placement of Crimped Contact in Housing

The contact must be inserted in the back of the housing and snapped into place. For the plug housings, install the contact so the wire barrel is facing the housing latch. For the receptacles, orientation of the contact can be in either direction. When fully inserted, the locking lances will engage the housing and prevent backing out during mating of the connector. After inserting contact into housing, pull back lightly on the wire to ensure contact is fully seated. See Figure 6.

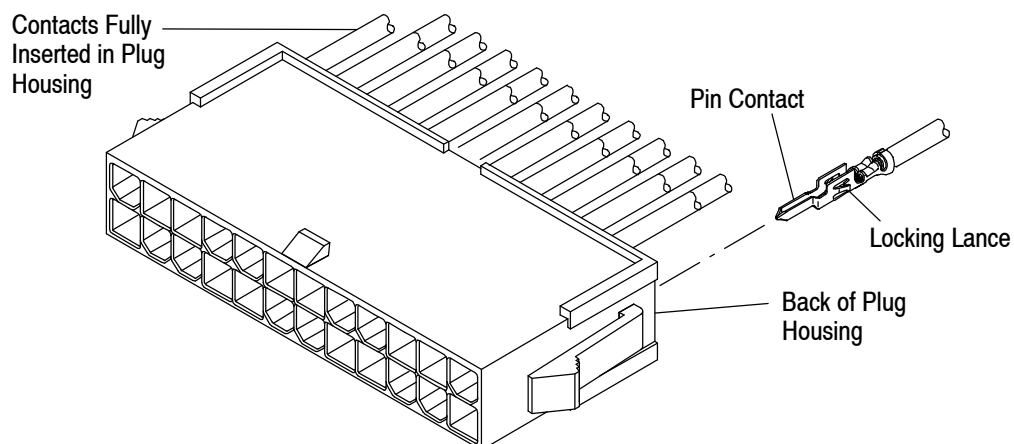

Figure 6

3.6. Strain Relief and Wire Dress

If required, wires can be bundled together and supported with cable ties. Wires must not be stretched or confined in any way that would restrict the floating action of the contacts. Therefore, the wires must remain perpendicular to the connector and avoid an excessively sharp bend radius. The minimum distance for the cable tie, measured from the wire end of the connector to the cable tie is shown in Figure 7.

Also, refer to Instruction Sheet 408-8330 for information on assembly of the strain relief for the 6-position AMP-DUAC Connector.

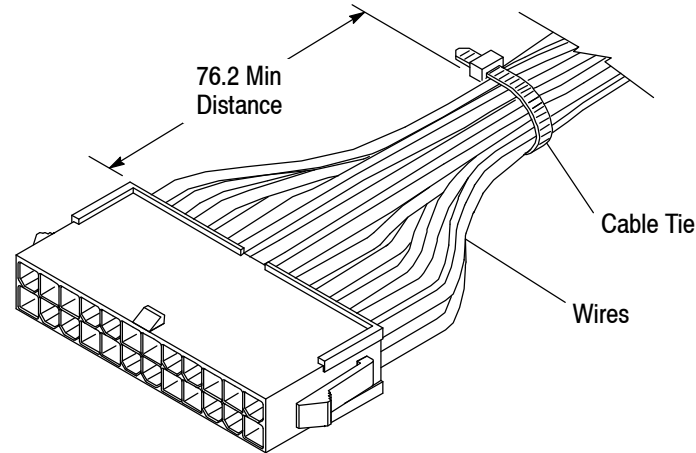

Figure 7

3.7. Connector Assembly

The plug and receptacle connectors will mate according to the polarization designed in the housings. Once the connectors have been mated, the latch will secure them from becoming unmated. See Figure 8.

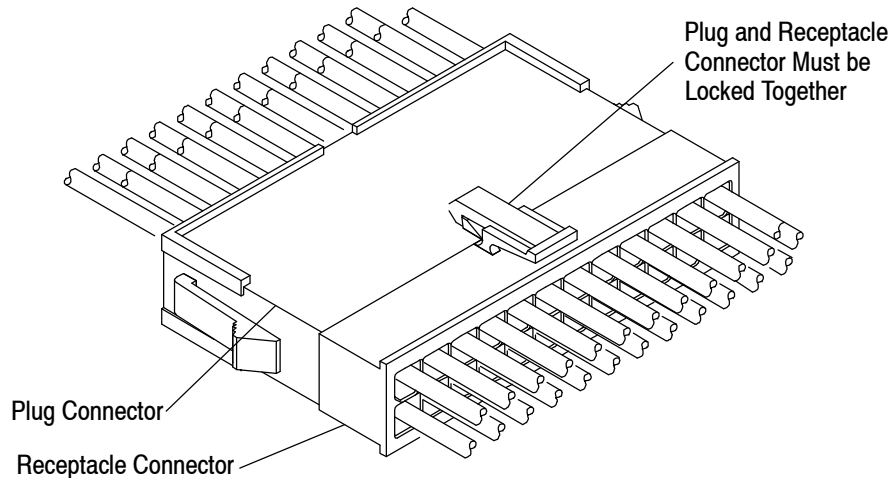

Figure 8

3.8. Wire Bend Radius

TE Engineering recommends that individual cables should be dressed to a bend radius of *at least* ten times the cable outside diameter. Likewise, cable bundles should be dressed to a bend radius of *at least* ten times the diameter of the bundle.

3.9. Panel Cutout

AMP-DUAC Connector panel cutouts shall be as indicated in Figure 9. No mounting hardware is required. The plug housing features flexible mounting tabs for insertion into the panel. Push the plug connector through the panel – in the same direction as the cutout was made – until it snaps in place.

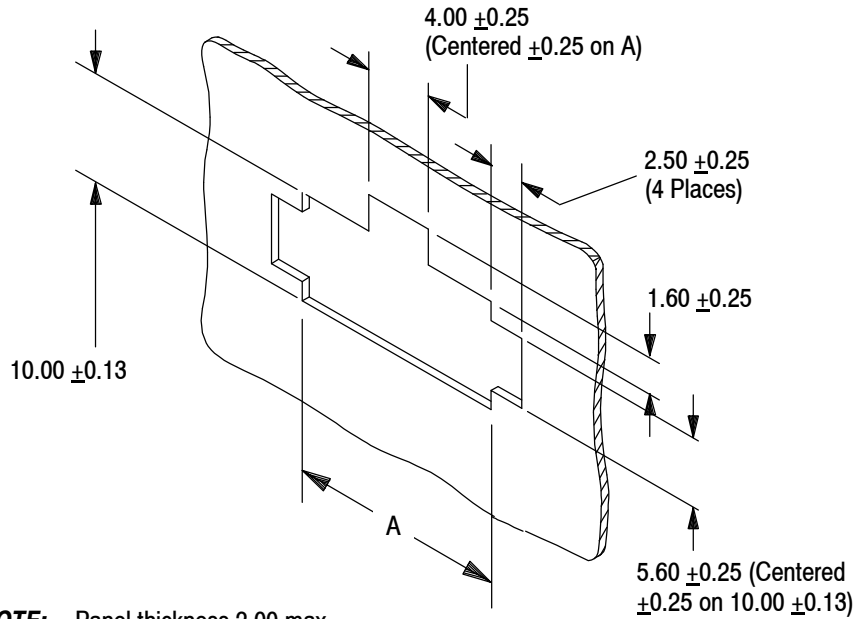

NUMBER OF CIRCUIT POSITIONS	"A" ±0.13
2	5.80
4	10.00
6	14.20
8	18.40
10	22.60
12	26.80
14	31.00
16	35.20
18	39.40
20	43.60
22	47.80
24	52.00

Figure 9

3.10. Header Assemblies

The pc board right-angle and vertical header assemblies are supplied with pre-installed contacts that have right-angle or vertical solder tines. They are designed to mate with connectors that have precision formed, crimp-type contacts inserted into 2- through 24-position housings. The vertical header assemblies are soldered to the pc board with or without pegs or drain holes. See Figure 1.

3.11. PC Board

A. Material and Thickness

1. Board material will be glass epoxy (FR-4, G-10).
2. Board thickness shall be 1.78 mm Max.

Contact the Product Information Center or the Tooling Assistance Center number listed at the bottom of page 1 for suitability of other board materials or thicknesses.

B. Tolerance

Maximum allowable bow of the pc board shall be 0.03 mm over the length of the header assembly.

C. PC Board Layout

The mounting and contact holes in the pc board must be precisely located to ensure proper placement and optimum performance of the header assembly. Design the pc board using the dimensions provided in Figure 10. The layout shows the top (component) side of the board.

Typical Vertical Header with or without
Pegs and with or without Drain Holes

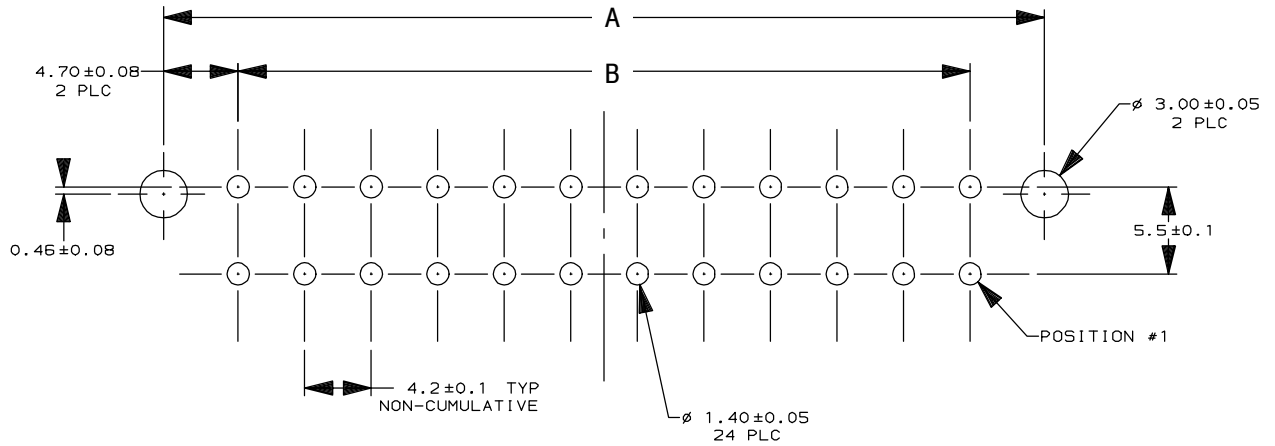

Typical Right-Angle
Header with Pegs

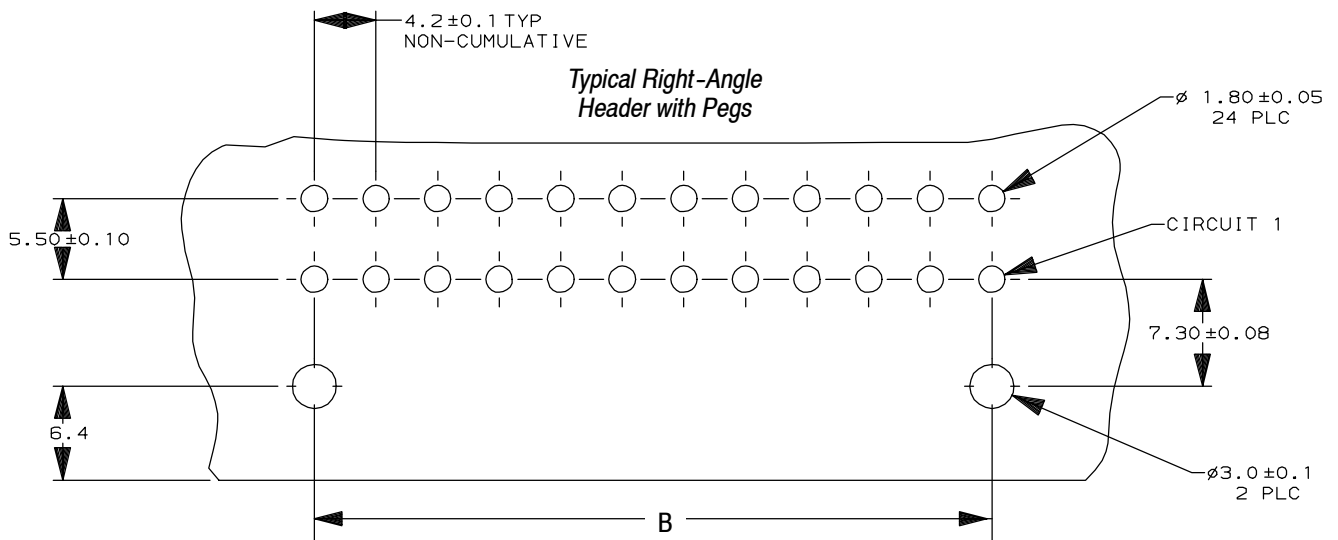

NUMBER OF CIRCUITS	DIMENSION	
	"A"	"B"
2	9.4	0.0
4	13.6	4.2
6	17.8	8.4
8	22.0	12.6
10	26.2	16.8
12	30.4	21.0
14	34.6	25.2
16	38.8	29.4
18	43.0	33.6
20	47.2	37.8
22	51.4	42.0
24	55.6	46.2

Figure 10

3.12. PC Board Solder Tine Holes

The holes in the pc board for the solder tines must be drilled and plated through to specific dimensions. See Figure 11.

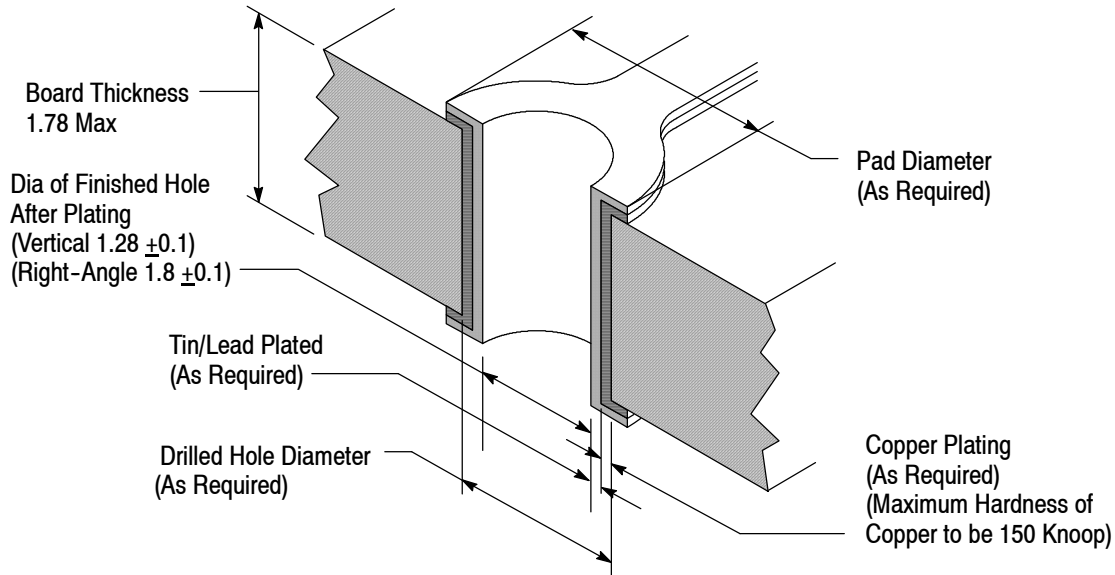

Figure 11

3.13. PC Board Header Assembly Placement



The header assemblies should be handled only by the housing to prevent deformation or other damage to the solder tines.

A. Manual Placement

Align the header assembly solder tines with the appropriate holes in the pc board. Start all solder tines into the board, then press on the header until it seats on the pc board.

B. Robotic Placement

The robotic equipment must be adjusted to feed, pick up, and place the headers on the pc board with an accuracy of 0.25. The header assembly datum surfaces detailed on the customer drawing will ensure correct placement of the header. For information on robotic equipment, see Section 5, TOOLING.

3.14. Soldering

A. Flux Selection

Contact solder tines must be fluxed prior to soldering with a mildly active, rosin base flux. Selection of the flux will depend on the type of pc board and other components mounted on the board. Additionally, the flux must be compatible with the wave solder line, manufacturing, health, and safety requirements. Call the Product Information phone number at the bottom of page 1 for consideration of other types of flux. Some fluxes that are compatible with these header assemblies are provided in Figure 12.

FLUX TYPE	ACTIVITY	RESIDUE	COMMERCIAL DESIGNATION	
			KESTER	ALPHA
Type RMA (Mildly Activated)	Mild	Noncorrosive	186	611

Figure 12

B. Soldering Guidelines

AMP-DUAC Header Assemblies can be soldered using a variety of soldering techniques. The temperatures and exposure time shall be within the ranges specified in Figure 13. We recommend using SN60 or SN62 solder for these header assemblies.

NOTE *Manual 402-40 provides some guidelines for establishing soldering practices. Refer to Paragraph 2.4, Manuals.*

SOLDERING PROCESS	TEMPERATURE		TIME (At Max Temperature)
	CELSIUS	FAHRENHEIT	
Wave Soldering	260●	500●	5 Seconds
Infrared Reflow Soldering◇	240	464	30 Seconds

●Wave Temperature ◇Applies to Black High-temperature Headers Only

Figure 13

C. Reflow Parameters for High Temperature Headers

Due to the many variables involved with the reflow process (e.g., component density, orientation, etc.), TE recommends that the user conduct trial runs under actual manufacturing conditions to ensure product and process compatibility. For reference purposes only, see recommendations provided in Figure 14, for typical reflow parameters.

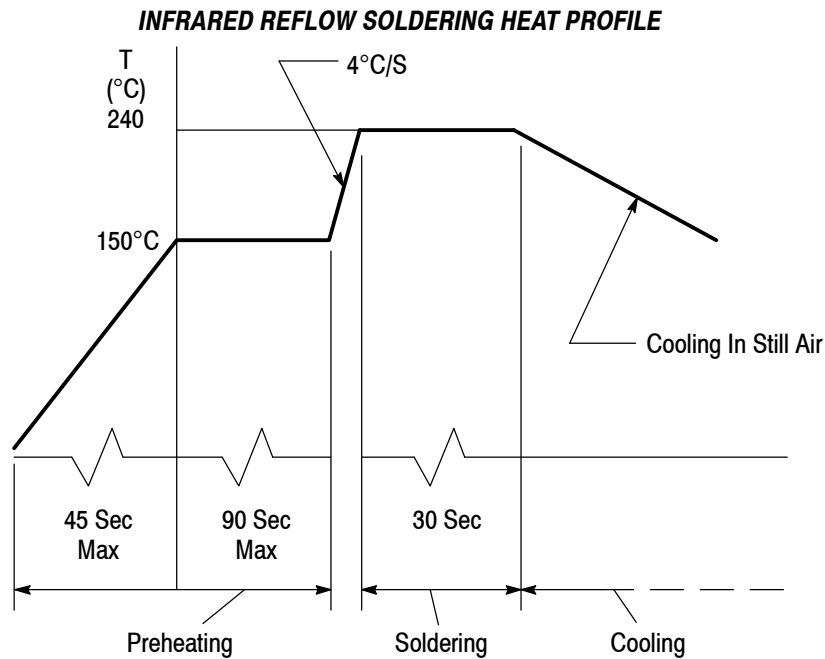

NOTE: IR reflow solder: Preheat at 3°C/sec to 150°C, reflow at 240°C or 30 seconds.

PREHEAT 350°C [662°F]	ZONE 1	ZONE 2	ZONE 3
	150°C [464°F]	150°C [302°F]	240°C [464°F]

Figure 14

D. Cleaning

After soldering, removal of fluxes, residues, and activators is necessary. Consult with the supplier of the solder and flux for recommended cleaning solvents. The following is a listing of common cleaning solvents that will not affect the header assemblies for the time and temperature specified. See Figure 15.



Consideration must be given to toxicity and other safety requirements recommended by the solvent manufacturer. Refer to the manufacturer's Material Safety Data Sheet (MSDS) for characteristics and handling of cleaners. Trichloroethylene and Methylene Chloride can be used with no harmful affect to the header assemblies; however TE does not recommend them because of the harmful occupational and environmental effects. Both are carcinogenic (cancer-causing) and Trichloroethylene is harmful to the earth's ozone layer.

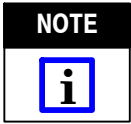

If you have a particular solvent that is not listed, contact the Tooling Assistance Center or Product Information number at the bottom of page 1.

CLEANER		TIME (Minutes)	TEMPERATURES (Maximum)	
NAME	TYPE		CELSIUS	FAHRENHEIT
ALPHA 2110	Aqueous	1	132	270
BIOACT EC-7	Solvent	5	100	212
Butyl CARBITOL	Solvent	1	Room Ambience	
Isopropyl Alcohol	Solvent	5	100	212
KESTER 5778	Aqueous	5	100	212
KESTER 5779	Aqueous	5	100	212
LONCOTERGE 520	Aqueous	5	100	212
LONCOTERGE 530	Aqueous	5	100	212
Terpene Solvent	Solvent	5	100	212

Figure 15

E. Drying

When drying cleaned assemblies and printed circuit boards, make certain that temperature limitations are not exceeded: -105°C [221°F] max for a period of 5 minutes for standard temperature products. Excessive temperatures may cause header assembly degradation. Values may vary with different types of automatic cleaning equipment. See the equipment manufacturers recommendations.

3.15. Checking Installed Header Assemblies

The header assemblies must be seated on the pc board to the dimensions shown in Figure 16.

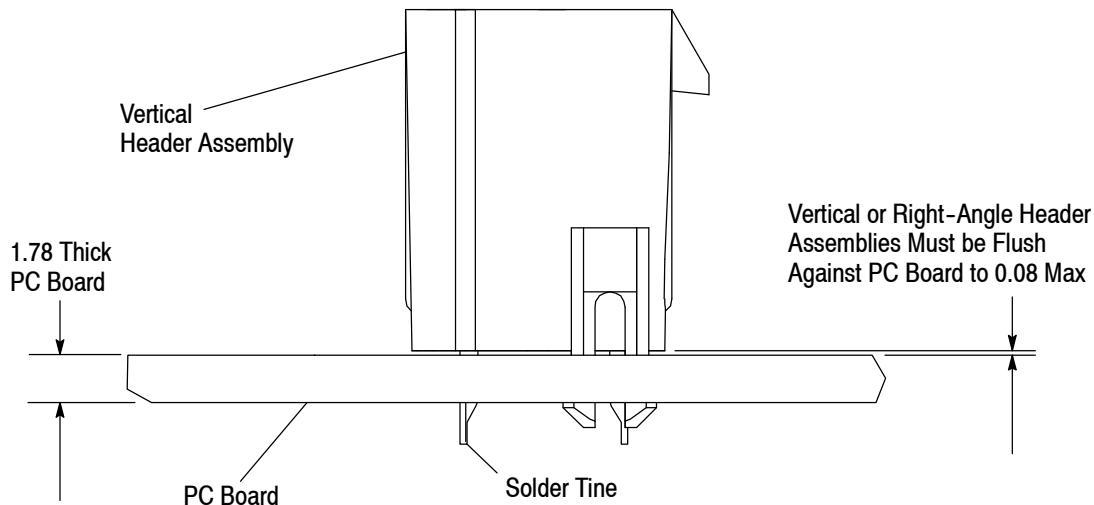

Figure 16

3.16. Polarization

The configuration of the AMP-DUAC Connector mating cavities prevents accidental inversion when mating the two components.

3.17. Mating of Connectors

To ensure a proper circuit connection, the receptacle connector latch must fully engage the header assembly locking ramp.

3.18. Header Assembly Spacing

Care must be used to avoid interference between adjacent header assemblies and/or other components. If robotic equipment is used, space allowances will be required for the grippers.

3.19. Repair/Removal

Use an extraction tool to remove individual contacts from connectors for replacement or for relocation to another housing cavity. Extraction Tool 188688-1 is used to extract contacts from receptacle connectors. See Figure 17. Reset the locking lances to the original spread before reusing contacts. Damaged or worn contacts may be replaced provided there is sufficient slack, after restripping the wire, to insert the new contact into the connector. Refer to Section 5, TOOLING. Damaged pc board header assemblies may be removed from the pc board by standard de-soldering methods.

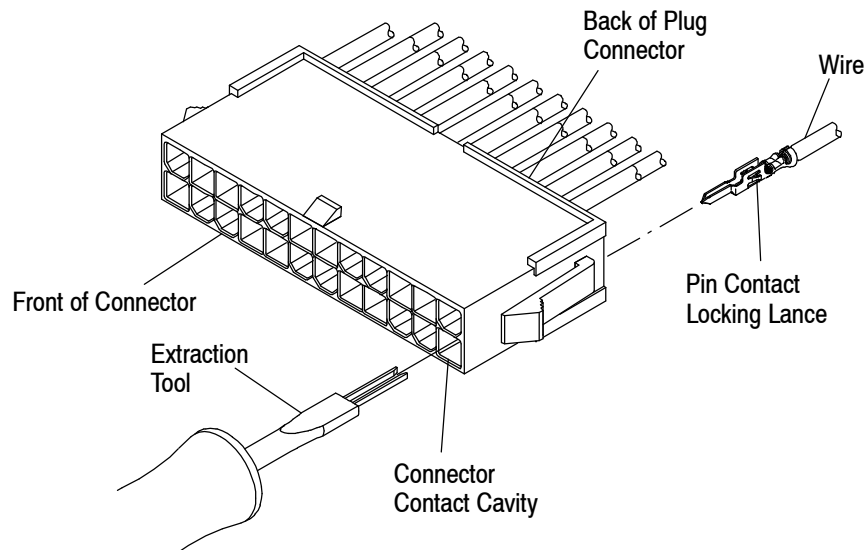

Figure 17

4. QUALIFICATIONS

AMP-DUAC Connectors are Recognized by Underwriters Laboratories Inc. (UL) in File E28476 and Certified by CSA International in File LR7189.

5. TOOLING

A listing of tooling recommendations covering the full wire size range is provided in Figure 18. The listing includes hand tools for manual application of loose piece contacts, and semi-automatic and automatic machines for power assisted application of strip form contacts. Modified designs and additional tooling concepts may be available to meet other application requirements. For additional information, contact one of the service groups at the bottom of page 1.

NOTE



TE Tool Engineers have designed machines for a variety of application requirements. For assistance in setting up prototype and production line equipment, contact Tool Engineering through your local TE Representative or call the Tooling Assistance Center number at the bottom of page 1.

- **Hand Crimping Tools**

Hand crimping tools that accommodate the full wire size range are designed for prototype and low-volume applications such as repair of damaged contacts.

- **Applicators**

Applicators are designed for the full wire size range of strip-fed, precision formed contacts, and provide for high volume, heavy duty production requirements. The applicators can be used in bench or floor model power units.

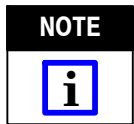

Each applicator is shipped with a metal identification tag attached. DO NOT remove this tag or disregard the information on it. Also, a packet of associated paperwork is included in each applicator shipment. This information should be read before using the applicator; then it should be stored in a clean, dry area near the applicator for future reference. Some changes may have to be made to the applicators to run in all related power units. Contact the Tooling Assistance Center number at the bottom of page 1 for specific changes.

Power Units

A power unit is an automatic or semi-automatic device used to assist in the application of a product. Power unit includes the power source used to supply the force or power to an applicator.



The Model “K” AMP-O-LECTRIC Terminating Machine PN 565435-5 (409-5128) has been superseded by the Model “G” Terminating Machine PN 354500-1 (409-5842) for new applications. For existing applications, the Model “K” is still recommended because of the large number of installed machines.

Robotic Equipment

Robotic equipment for placement of the header assemblies on a pc board must have a true position accuracy of 0.25 to ensure proper location and insertion of the solder tines. This includes gripper and fixture tolerances as well as equipment repeatability. It must use the assembly datum surface to ensure reliable header placement. If you need assistance in setting up prototype or production line equipment, contact Tooling Engineering through your local TE Representative or call the Tooling Assistance Center number at the bottom of page 1.

PC Board Support

A pc board support must be used to prevent bowing of the pc board during insertion of the headers. It should have a flat surface with holes or a channel large enough to receive the solder tines during installation.

Extraction Tools

Extraction Tools are designed to release the contacts inside the receptacle connector without damaging the housing or contacts. Refer to Paragraph 3.19.

WIRE SIZE, mm ² [AWG]	INSULATION DIA RANGE	APPLICATION TOOLING			
		APPLICATOR (DOCUMENT)	POWER UNIT (DOCUMENT)	HAND TOOL (DOCUMENT)	EXTRACTION TOOL (DOCUMENT)
0.12-0.30 [26-22]	1.19-1.75	567960-1	1320895-1 (409-10012)	734202-3	
		680307-1 (408-8040)	122500-2, -3 (409-5852)		
			356500-1, -2 (409-5878)		
		680307-2 (408-8040)	354500-1 (409-5842)		
		680307-3 (408-8040)	565435-5 (409-5128)		
0.30-0.80 [22-18]	1.50-2.39	567959-1	1320895-1 (409-10012)	734202-2	188688-1
		680308-1 (408-8040)	122500-2, -3 (409-5852)		
			356500-1, -2 (409-5878)		
		680308-2 (408-8040)	354500-1 (409-5842)		
		680308-3 (408-8040)	565435-5 (409-5128)		
2 [18] or 1 [16]	3.30 Max	680350-1 (408-8040)	122500-2, -3 (409-5852)	90714-1 (408-4385)	
			356500-1, -2 (409-5878)		
		680350-2 (408-8040)	354500-1 (409-5842)		
		680350-3 (408-8040)	565435-5 (409-5128)		

Figure 18 (cont'd)

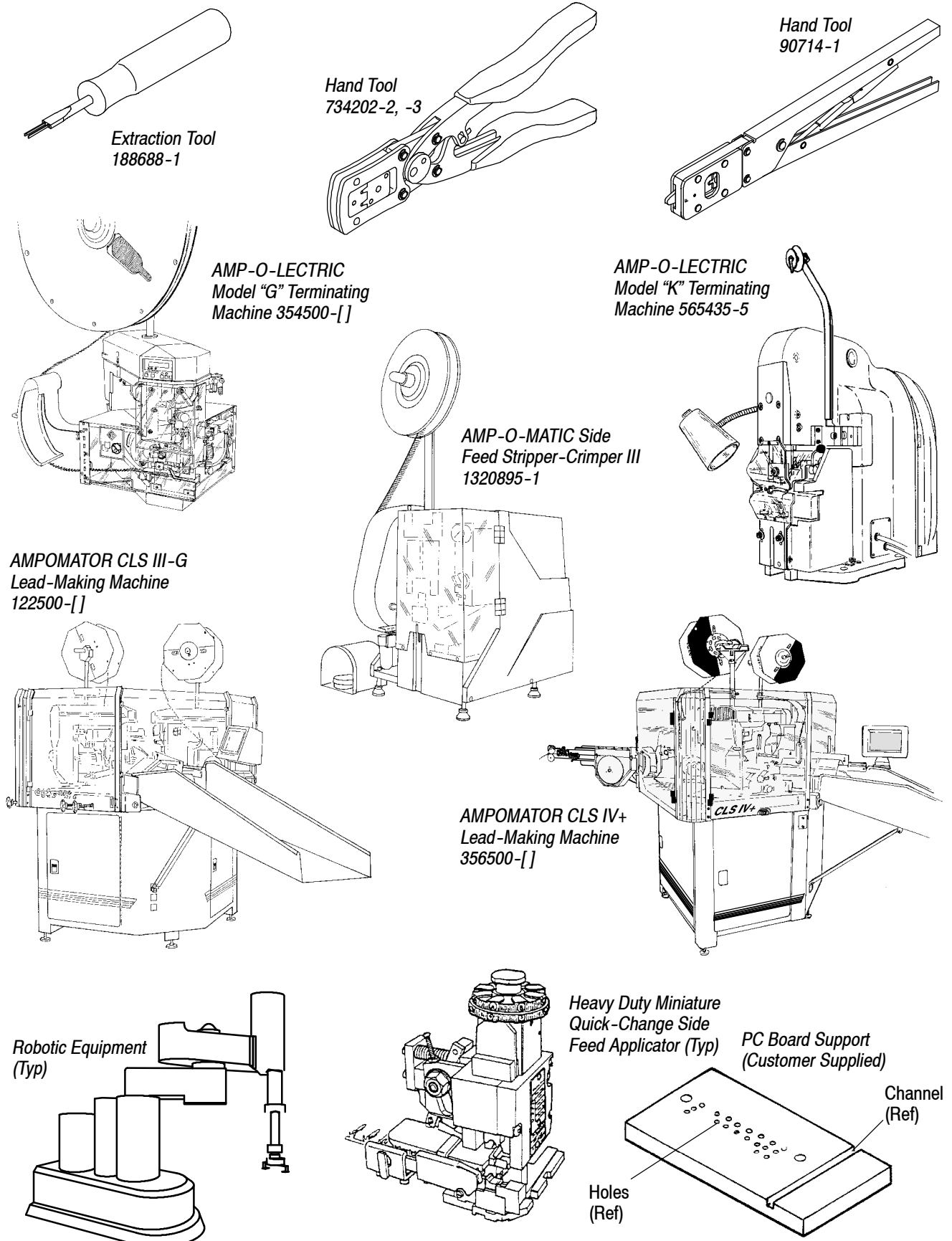

Figure 18 (end)

6. VISUAL AID

Figure 19 shows a typical application of AMP-DUAC Connectors. This illustration should be used by production personnel to ensure a correctly applied product. Applications which DO NOT appear correct should be inspected using the information in the preceding pages of this specification and in the instructional material shipped with the product or tooling.

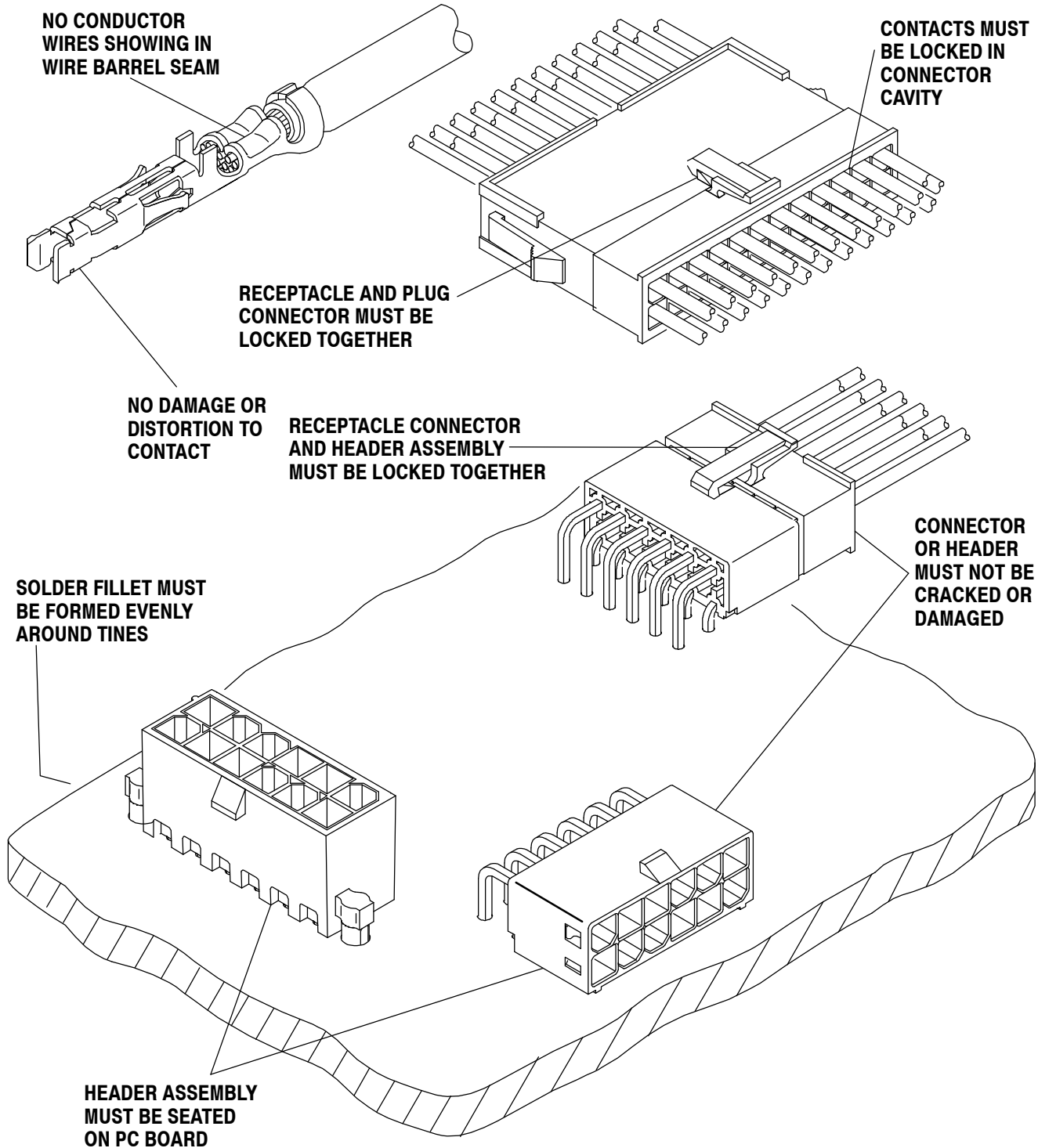



FIGURE 19. VISUAL AID

Looking for pricing, stock, or lifecycle information?

Click below to explore more details on WIN SOURCE:

 [View 106529-2 on WIN SOURCE](#)

 [TE Connectivity](#) Information

Optimize Your Supply Chain with WIN SOURCE Solutions

-  Global Sourcing Solution
-  Obsolete Management
-  Cost Control Management
-  Shortage Management
-  Alternative Solution
-  Excess Inventory Management