

Quad Boost Amplifier

■ GENERAL DESCRIPTION

The **NJM2792** is a quad boost amplifier designed for car audio system. It expands the frequency characteristics by high slew rate.

It can swing 14V peak-to-peak output voltage at 9V. It consists of four channel non-inverting amplifier with the gain of 8dB.

It is suitable for car audio system and other boost amplifier system.

■ PACKAGE OUTLINE

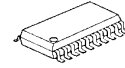

NJM2792V

■ FEATURES

- Operating Voltage (6 to 11V)
- Operating Current (12mA typ.)
- Boost output Function ($V_o=14V_{pp}:@V^+=9V$)
- Maximum Output Voltage (4.5Vrms typ., @ f=100kHz)
- Supply Voltage Rejection Ratio (50dB typ.)
- Total Harmonic Distortion (0.003% typ.)
- Noise Output Voltage (5 μ Vrms typ.)
- Bipolar Technology
- Package Outline SSOP20

■ BLOCK DIAGRAM

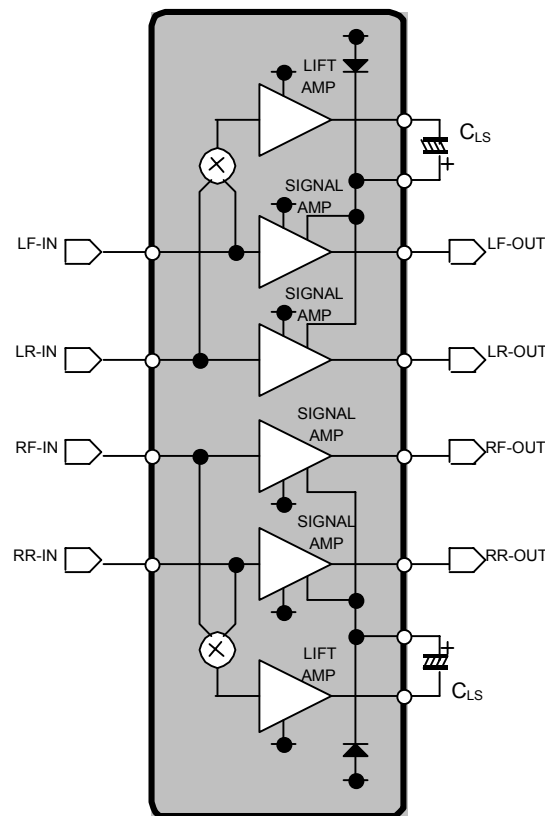

■PIN CONFIGURATION

1	L-GND	L-CIN	20
2	L-COUT	RL-OUT	19
3	FL-OUT	RL-FB	18
4	FL-FB	RL-IN	17
5	FL-IN	V+	16
6	REF	RR-IN	15
7	FR-IN	RR-FB	14
8	FR-FB	RR-OUT	13
9	FR-OUT	R-CIN	12
10	R-COUT	R-GND	11

No.	Symbol	Function	No.	Symbol	Function
1	L-GND	Ground for Left Channel	11	R-GND	Ground for Right Channel
2	L-COUT	Capacitor for - Level Shift Left Channel	12	R-CIN	Capacitor for + Level Shift Right Channel
3	FL-OUT	Output for Front Left Channel	13	RR-OUT	Output for Rear Right Channel
4	FL-FB	- Input for Front Left Channel	14	RR-FB	- Input for Rear Right Channel
5	FL-IN	+ Input for Front Left Channel	15	RR-IN	+ Input for Rear Right Channel
6	REF	Reference Voltage	16	V+	Power Supply
7	FR-IN	+ Input for Front Right Channel	17	RL-IN	+ Input for Rear Left Channel
8	FR-FB	- Input for Front Right Channel	18	RL-FB	- Input for Rear Left Channel
9	FR-OUT	Output for Front Right Channel	19	RL-OUT	Output for Rear Left Channel
10	R-COUT	Capacitor for - Level Shift Right Channel	20	L-CIN	Capacitor for + Level Shift Left Channel

■ ABSOLUTE MAXIMUM RANGES (Ta=25°C)

PARAMETER	SYMBOL	RANGE	UNIT
Supply Voltage	V ⁺	+15	V
Power Dissipation	P _D	550 NOTE: EIA/JEDEC STANDARD Test board (76.2x114.3x1.6mm, 2layer, FR-4) mounting	mW
Operating Temperature	Topr	-40 to +85	°C
Storage Temperature	Tstg	-40 to +125	°C

■ ELECTRICAL CHARACTERISTIC (V⁺=9V, Ta=25°C)

PARAMETER	SYMBOL	TEST CONDITION	MIN.	TYP.	MAX.	UNIT
DC CHARACTERISTIC						
Operating Voltage	V ⁺		6.0	9.0	11.0	V
Operating Current	I _{CC}	No Signal	-	12.0	18.0	mA
Output Voltage	V _{ODC}		-	7.8	-	V
AC CHARACTERISTIC (f=1kHz, V_O=1Vrms, R_L=10kΩ)						
Voltage Gain	A _v		7.5	8.0	8.5	dB
Channel Separation 1	CS1	R _S =600Ω, V _O =1Vrms, f = 1kHz, Front channel vs. Rear channel	70	80	-	dB
Channel Separation 2	CS2	R _S =600Ω, V _O =1Vrms, f = 1kHz, L channel vs. R channel	-	100	-	dB
Channel Balance	BAL		-	-	0.5	dB
Roll-off Low Frequency	f _{RL}	-1dB	-	5	-	Hz
Roll-off High Frequency	f _{RH}	-1dB	100	-	-	kHz
Input Resistance	R _{IN}		44	60	76	kΩ
Output Resistance	R _{OUT}		-	2	-	Ω
Maximum Output Voltage 1	V _{OM1}	THD=0.1%, f = 1kHz	5.0	5.2	-	Vrms
Maximum Output Voltage 2	V _{OM2}	THD=1%, f = 100kHz	-	4.5	-	Vrms
Noise Output Voltage	V _{NO}	R _S =0Ω, A-Weighting	-	5	10	μVrms
Total Harmonic Distortion	THD1	f=1kHz, V _O =3Vrms, A-Weighting	-	0.003	0.01	%
	THD2	f=17Hz to 20kHz, V _O =3Vrms, A-Weighting	-	0.01	-	%
Supply Voltage Rejection Ratio	SVR1	R _S =0Ω, f=1kHz, V _{RP} =100mVrms	55	-	-	dB
	SVR2	R _S =0Ω, f=20Hz to 20kHz, V _{RP} =100mVrms	-	50	-	dB

■ TERMINAL DESCRIPTION

PIN NO.	SYMBOL	FUNCTION	EQUIVALENT CIRCUIT	TERMINAL DC VOLTAGE
2 10	L-COUT R-COUT	Capacitor for - Level Shift Left Channel Capacitor for - Level Shift Right Channel		$(V^+ - 1.4) \times 0.09$ [V]
12 20 3 9 13 19	R-CIN L-CIN FL-OUT FR-OUT RR-OUT RL-OUT	Capacitor for + Level Shift Right Channel Capacitor for + Level Shift Left Channel Output for Front Left Channel Output for Front Right Channel Output for Rear Right Channel Output for Rear Left Channel		$V^+ - 0.7$ [V] (12,20PIN) $V^+ - 1.4$ [V] (3,9,13,19PIN)
4 8 14 18 5 7 15 17	FL-FB FR-FB RR-FB RL-FB FL-IN FR-IN RR-IN RL-IN	- Input for Front Left Channel - Input for Front Right Channel - Input for Rear Right Channel - Input for Rear Left Channel + Input for Front Left Channel + Input for Front Right Channel + Input for Rear Right Channel + Input for Rear Left Channel		$(V^+ - 1.4) \times 0.4$ [V]

■ TERMINAL DESCRIPTION

PIN NO.	SYMBOL	FUNCTION	EQUIVALENT CIRCUIT	TERMINAL DC VOLTAGE
6	REF	Reference Voltage		$(V^+ - 1.4) \times 0.6$ [V]

NJM2792

APPLICATION CIRCUIT

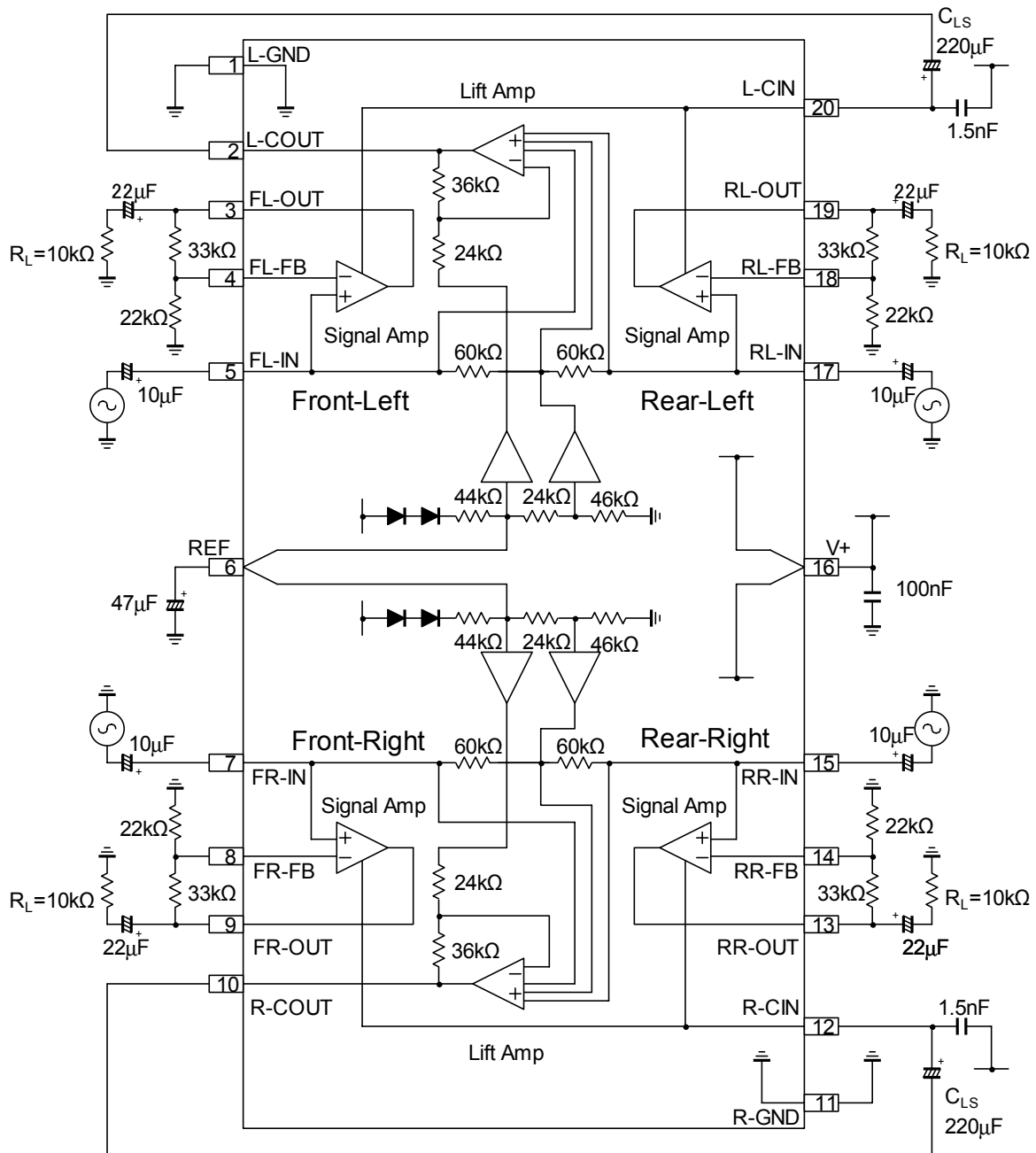

TYPICAL CHARACTERISTICS

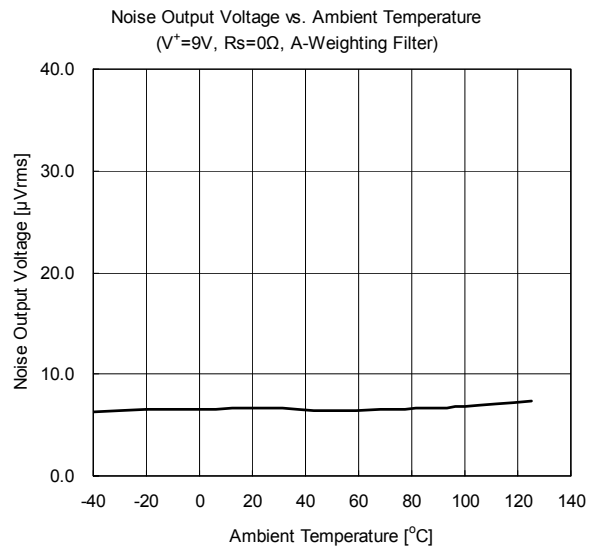
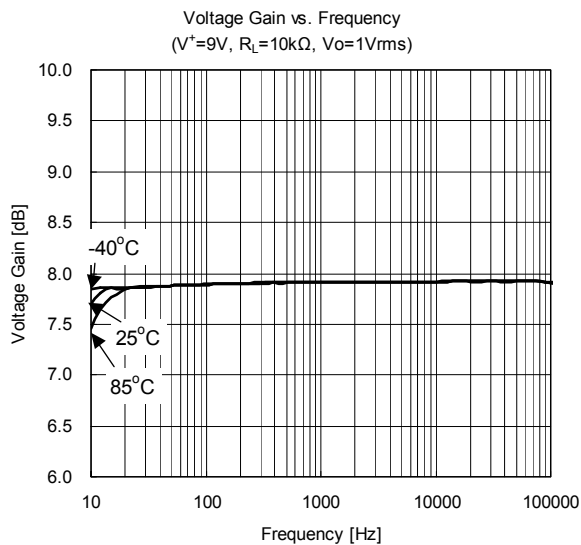
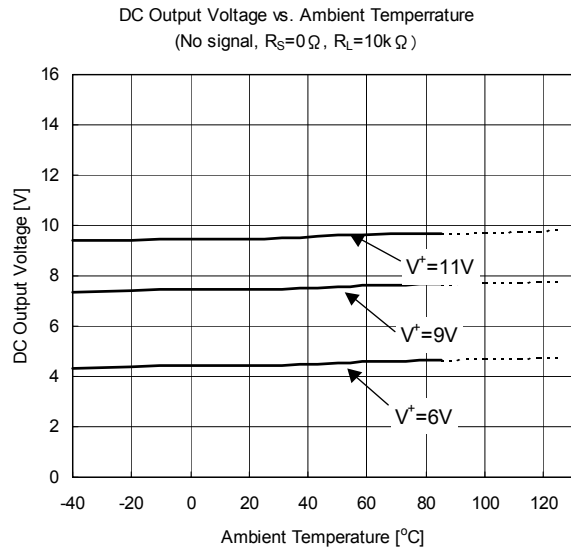
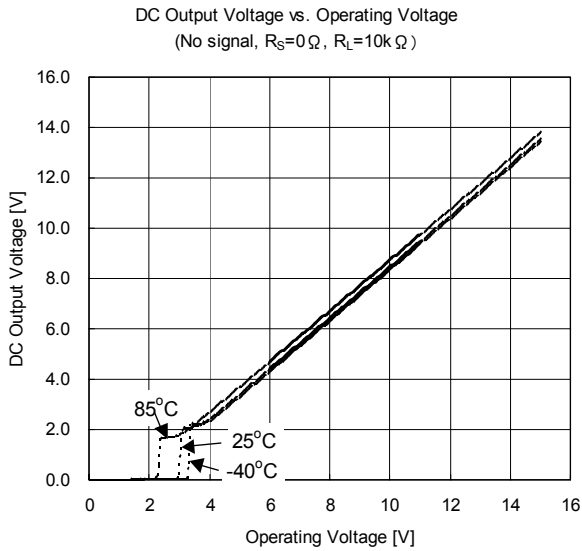
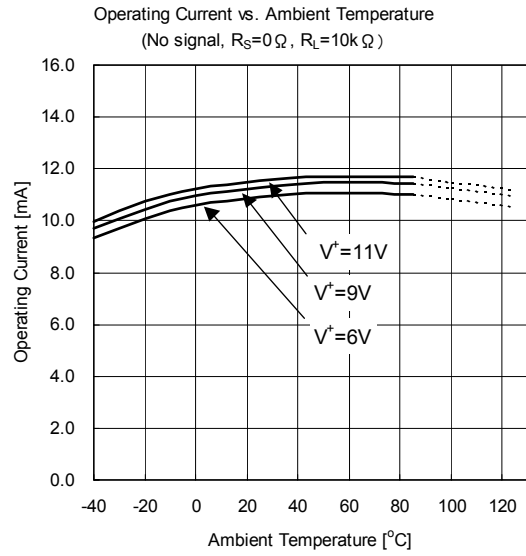
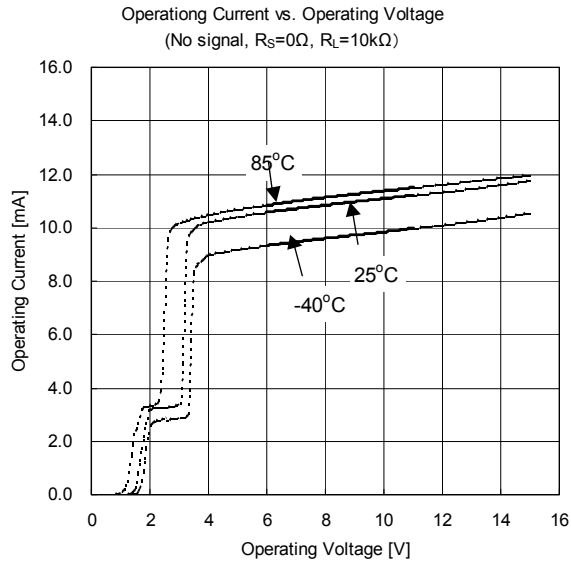

TYPICAL CHARACTERISTICS

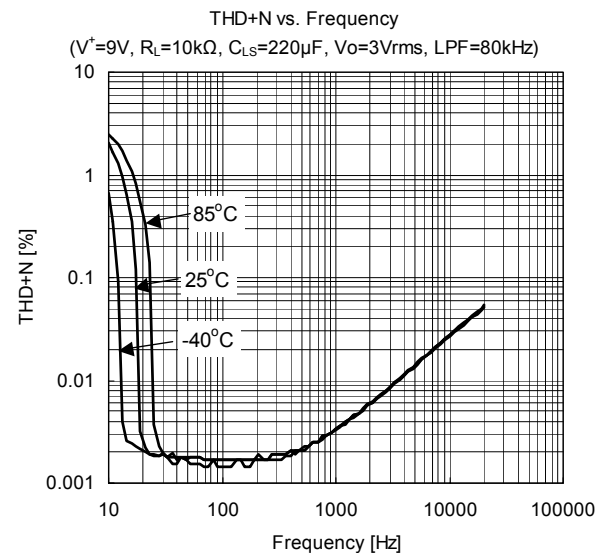
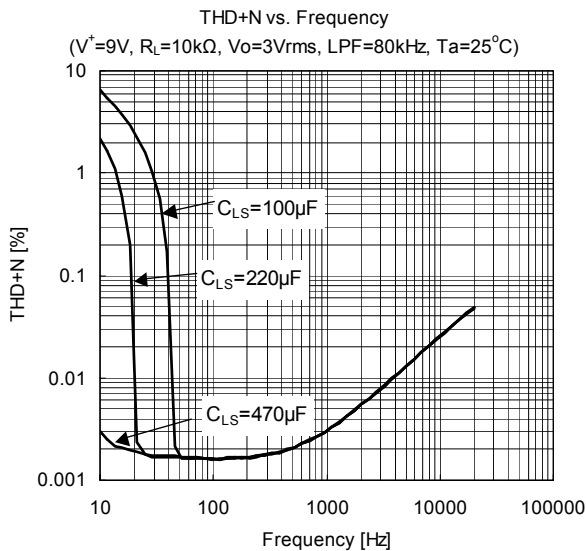
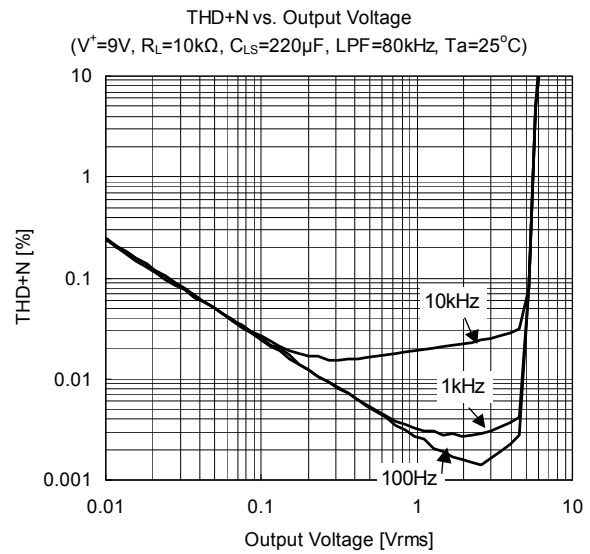
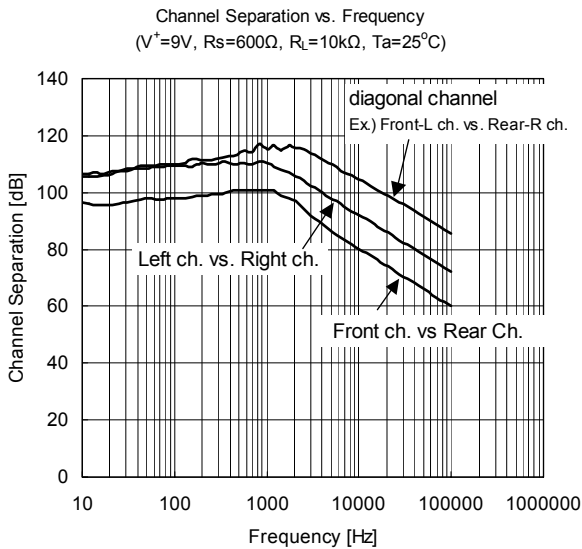
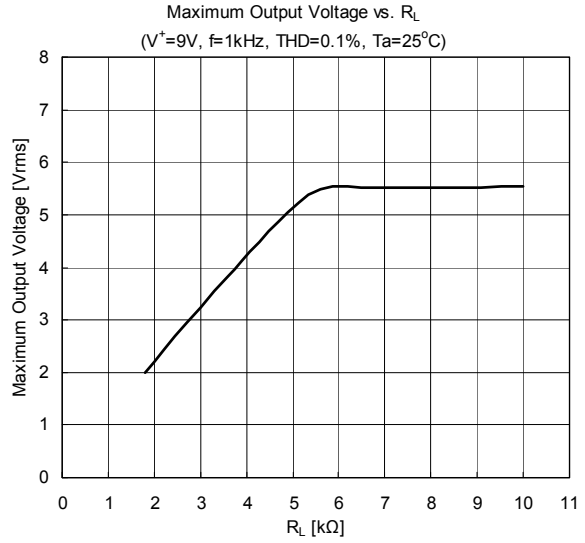
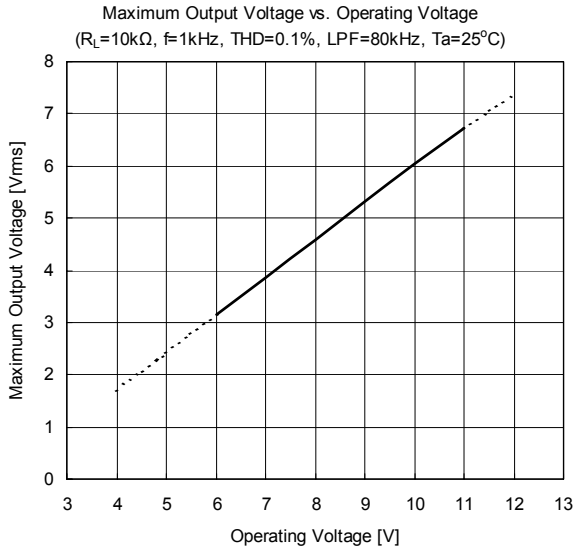

■ TYPICAL CHARACTERISTICS

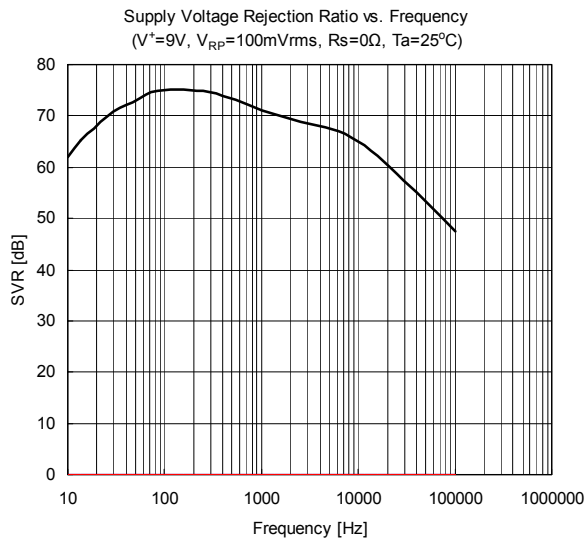

[CAUTION]
 The specifications on this databook are only given for information, without any guarantee as regards either mistakes or omissions. The application circuits in this databook are described only to show representative usages of the product and not intended for the guarantee or permission of any right including the industrial rights.

Mouser Electronics

Authorized Distributor

Click to View Pricing, Inventory, Delivery & Lifecycle Information:

[Nisshinbo Micro Devices:](#)

[NJM2792V-TE2](#) [NJM2792V-TE1](#)

Looking for pricing, stock, or lifecycle information?

Click below to explore more details on WIN SOURCE:

- ⊖ [View NJM2792V-TE2 on WIN SOURCE](#)
- ⊖ [Nisshinbo Micro Devices Inc. Information](#)

Optimize Your Supply Chain with WIN SOURCE Solutions

- ✓ Global Sourcing Solution
- ✓ Obsolete Management
- ✓ Cost Control Management
- ✓ Shortage Management
- ✓ Alternative Solution
- ✓ Excess Inventory Management