



THE DATASHEET OF
QPB9378TR13



Product Overview

The QPB9378 is a highly integrated RF front-end module targeted for 5G TDD base stations. The module integrates a two-stage LNA and a high-power SPDT switch in a dual channel configuration. It features a 2nd stage LNA with bypass functionality and power down mode for LNA when in transmit mode.

The QPB9378 can be operated across the 2.3 – 5.0 GHz range. It provides 1.25 dB noise figure and 33.5dB gain at 3.6 GHz for operation in the receive mode and 0.5 dB insertion loss in the transmit mode. The switch supports input RF power signals of up to 20 W average power assuming 9 dB PAR.

The QPB9378 is packaged in a RoHS-compliant, compact 6 x 6 mm surface-mount leadless package. The switch LNA module is targeted for wireless infrastructure applications configured for 5G TDD-based MIMO architectures.

Functional Block Diagram

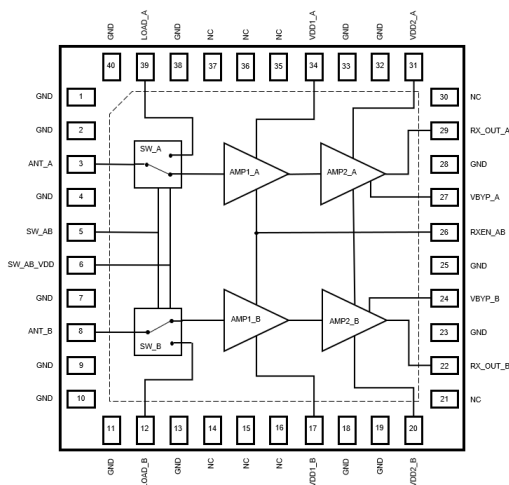

Top View

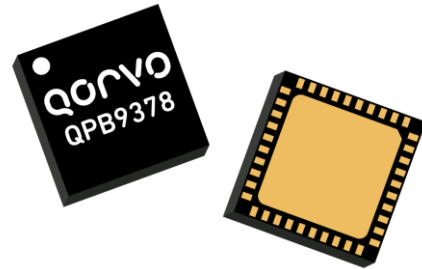

40 Pin 6 x 6 mm Leadless SMT Package

Key Features

- 2.3–5.0 GHz Frequency Range
- Dual Channel
- Low Gain mode with second stage LNA bypass
- 20 W average power handling (Tx mode)
- 33.5 dB Gain (Rx mode, High Gain state)
- 14.5 dB Gain (Rx mode, Low Gain state)
- +33 dBm OIP3 (Rx mode, High Gain state)
- +34.5 dBm OIP3 (Rx mode, Low Gain state)
- 1.25 dB Noise Figure (Rx mode)
- 0.5 dB Insertion Loss (Tx mode)
- Compact package size, 6 x 6 mm

Applications

- 5G m-MIMO
- Wireless Infrastructure
- Small cell BTS
- TDD-based architectures

Ordering Information

Part No.	Description
QPB9378EVB-01	2.3 - 4.2 GHz Evaluation Board
QPB9378EVB-02	4.4 – 5.0 GHz Evaluation Board
QPB9378TR13	2500 pcs on 13" reel (standard)

Absolute Maximum Ratings

Parameter	Rating
Storage Temperature	- 65 to +150°C
Supply Voltage (All VDD)	+6 V
Switch Control Voltage (SW12)	-0.3V to +5.8 V
Input Power, RX Mode (Avg, 9dB PAR, 100% DC, T _C 105°C)	+22 dBm
Input Power, TX Mode, > 10 yrs. (Avg, 9dB PAR, 8.8ms frame max 88% DC, T _C 105°C)	+43 dBm
Input Power, TX Mode, ≤10 sec. (Avg, 9dB PAR, 8.8ms frame max 88% DC, T _C 105°C)	+44 dBm

Exceeding any one or a combination of the Absolute Maximum Rating conditions may cause permanent damage to the device.

Recommended Operating Conditions

Parameter	Min	Typ	Max	Units
LNA Supply Voltage (VDD)	+4.75	+5	+5.25	V
T _{CASE}	-40		+105	°C
T _j (Tx path), >10 ⁶ hours MTTF			+125	°C
T _j (Rx path), >10 ⁶ hours MTTF			+190	°C

Electrical specifications are measured at specified test conditions. Specifications are not guaranteed over all recommended operating conditions. Application of conditions to the device outside the Recommended Operating Conditions may reduce device reliability and performance.

Electrical Specifications

Test conditions unless otherwise noted: All V_{DD} = +5V, Temp = +25 °C, 50 Ω system.

Parameter	Conditions	Min	Typ	Max	Units
Operational Frequency Range		2300		5000	MHz
Test Frequency			3600		MHz
Gain	Rx mode, High gain state	31.0	33.5		dB
	Rx mode, Low gain state	12.5	14.5		dB
Gain Flatness	Rx mode, High gain state, any 100 MHz		0.5		dB
	Rx mode, Low gain state, any 100 MHz		0.1		dB
Input Return Loss	Rx mode, High gain state		18.0		dB
	Rx mode, Low gain state		16.0		dB
	Tx mode		16.0		dB
Output Return Loss	Rx mode		20.0		dB
Noise Figure	Rx mode, High Gain state		1.25	1.6	dB
Output IP3	Rx mode, High gain state P _{out} = +2 dBm/tone, Δf = 1 MHz	28.0	33.0		dBm
	Rx mode, Low gain state P _{out} = +2 dBm/tone, Δf = 1 MHz	28.0	34.5		dBm
OP1dB	Rx mode, High gain state	15.6	18.3		dBm
	Rx mode, Low gain state		15.2		dBm
Switch Insertion Loss	Tx mode		0.5	0.9	dB

Electrical Specifications (Continued)

Test conditions unless otherwise noted: All $V_{DD} = +5V$, Temp = +25 °C, 50 Ω system.

Parameter	Conditions	Min	Typ	Max	Units
Switch Isolation	ANT to TX in RX mode		25.5		dB
	ANT to RX in TX mode		60.0		dB
Channel Isolation	Rx mode, RFIN_A to RFIN_B or RFOUT_A to RFOUT_B		40.0		dB
	Tx mode, RFIN_A to RFIN_B or LOAD_A to LOAD_B		40.0		dB
	Cross Isolation		40.0		
LNA Current	Rx mode, High gain state, both channels		230	300	mA
	Rx mode, Low gain state, both channels		116		mA
Switch Current	Tx mode, (LNA Off)		8		mA
Control Logic High Voltage		+1.2	+1.8	VDD+0.3	V
Control Logic Low Voltage		0		0.63	V
Logic Control Current	0V or +1.8V, Source or sink		± 150		μA
Switching Time	Switch between Rx mode and Tx mode, Ton/Toff (50% ctrl to 1/99% RF)		822		nsec
	Between high gain state and low gain state		573		nsec
Thermal Resistance, θ_{jc}	Tx Mode, 20W RFIN applied to one channel		4.7		$^{\circ}C/W$
	Rx Mode		21.4		$^{\circ}C/W$

Control Logic Truth Table

Parameter, V_{PD}	SW_AB ⁽¹⁾	RXEN_AB ⁽¹⁾	VBYP_AB
RX Mode, LNA Normal (High Gain)	0	0	0
RX Mode, LNA Bypass (Low Gain)	0	0	1
TX Mode, LNA Disable	1	1	X

Note:

1. Synchronize SW_AB and RXEN_AB for better performance and smooth transitions

Evaluation Board and Schematic – QPB9378EVB-01/02

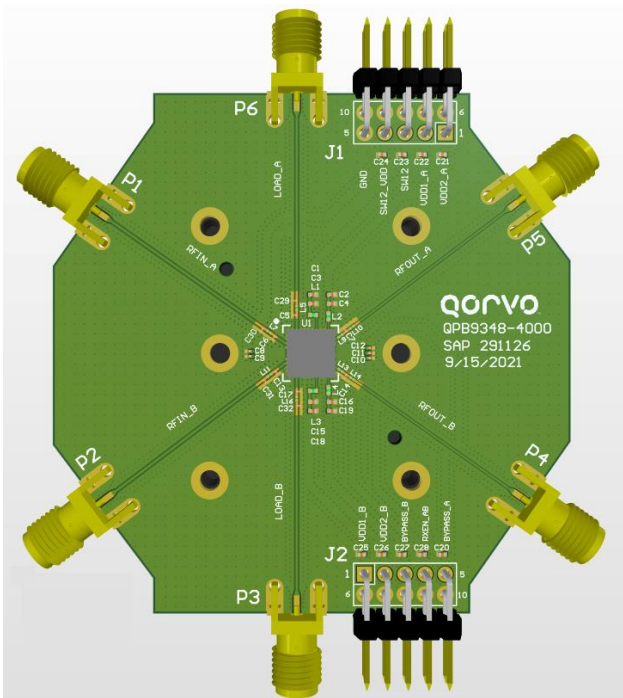
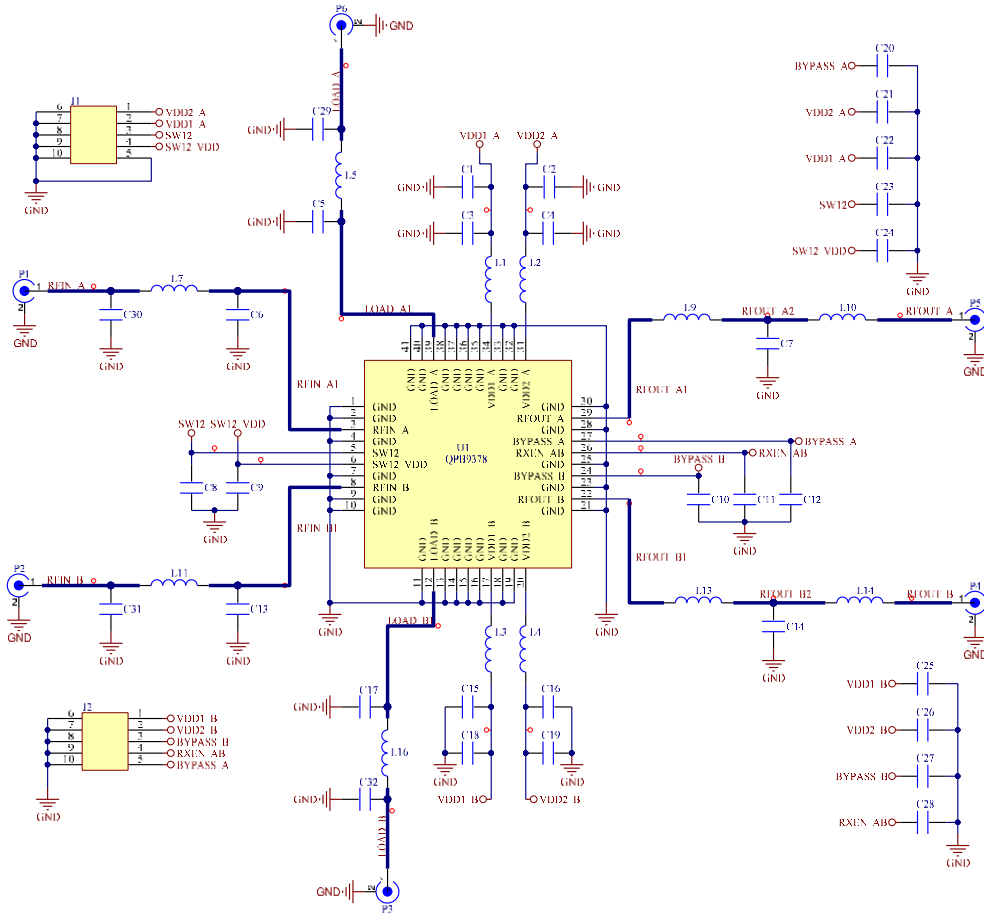

Top View

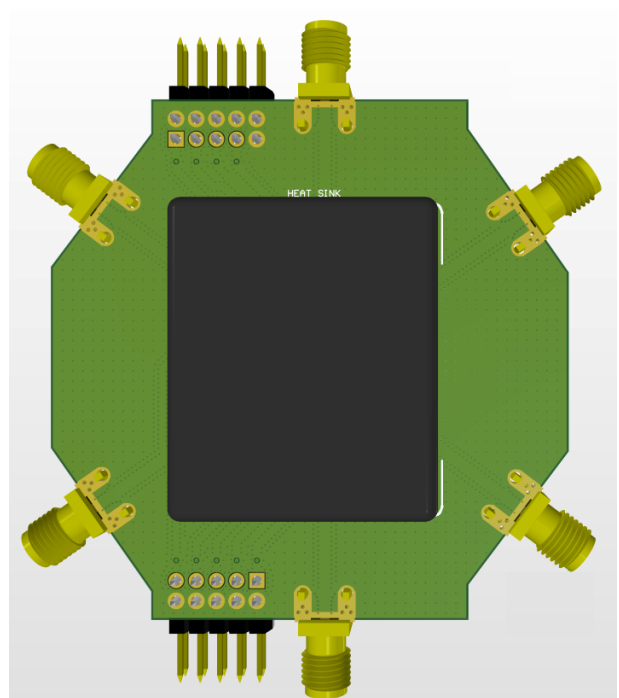

Bottom View

Bill of Material – QPB9378EVB-01

Reference Des.	Value	Description	Manuf.	Part Number
U1	NA	2.3-5 GHz 20W Switch-LNA Module	Qorvo	QPB9378
C23	10 pF	CAP, 5%, 50V, HI-Q, 0402	Murata	GJM1555C1H100JB01D
C11, L10, L14	10 pF	CAP, +/-0.5pF, 25V, C0G, 0201	Murata	GRM0335C1E100JA01J
C8, C10, C12	100 pF	CAP, 5%, 25V, C0G, 0201	Murata	GRM0335C1E101JA01D
C9	0.1 uF	CAP, 10%, 10V, X7R, 0201	Murata	GRM033Z71A104KE14D
C1, C2, C18, C19, C21, C22, C24, C25, C26	1 uF	CAP, 10%, 6.3V, X7R, 0402	Murata	GRM155R70J105KA12D
C20, C27	1000 pF	CAP, 10%, 50V, X7R, 0402	Johanson	500R07W102KV4T
C3, C4, C15, C16, C28	100 pF	CAP, 5%, 50V, NP0, 0402	Various	
L1, L2, L3, L4, L5, L7, L9, L11, L13, L16	0 Ω	JMPR, 0201	Kamaya	RMC1/20JPPA15

Typical Performance – QB9378EVB-01

Test conditions unless otherwise noted: $V_{DD} = +5\text{ V}$, Temp = $+25^\circ\text{C}$

Parameter	Conditions	Typical Values							Units
Frequency		2300	2500	2700	3300	3600	3800	4200	MHz
Gain	Rx High Gain Mode	31.1	31.0	30.9	31.9	32.9	33.8	36.0	dB
Input RL		15.4	27.3	23.4	15.5	17.5	20.6	21.6	dB
Output RL		19.4	15.2	13.4	18.5	23.4	19.2	15.1	dB
Noise Figure ⁽¹⁾		1.22	1.16	1.14	1.19	1.22	1.20	1.27	dB
OIP3 ⁽²⁾		32.5	32.8	33.6	34.4	33.5	33.4	32.2	dBm
Input P1dB		18.0	18.6	19.3	18.4	17.9	17.1	16.4	dBm
Cross Isolation		49.4	50.3	57.9	61.0	51.0	42.0	45.0	dB
Insertion Loss ⁽¹⁾		Tx Mode	0.2	0.3	0.3	0.4	0.5	0.5	0.5
Input Return Loss	29.4		26.7	24.5	16.5	15.2	15.3	15.7	dB
Output Return Loss	30.7		29.5	27.1	17.1	15.7	15.5	15.8	dB

Notes:

1. Input trace loss de-embedded from NF and IL data.
2. Pout/tone = +2 dBm, $\Delta f = 1\text{ MHz}$

Performance Plots – QPB9378EVB-01

Test conditions unless otherwise noted: $V_{DD} = +5\text{ V}$.

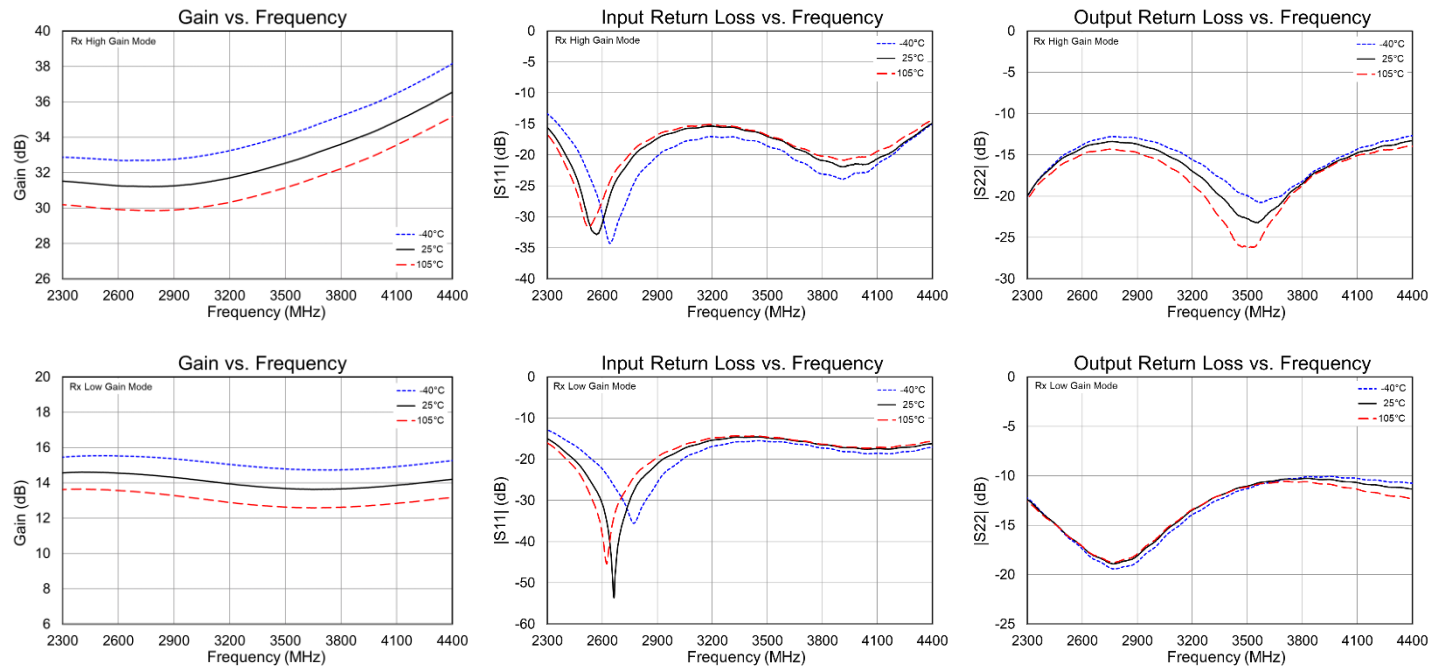

Performance Plots – QPB9378EVB-01 (Continued)

Test conditions unless otherwise noted: $V_{DD} = +5\text{ V}$.

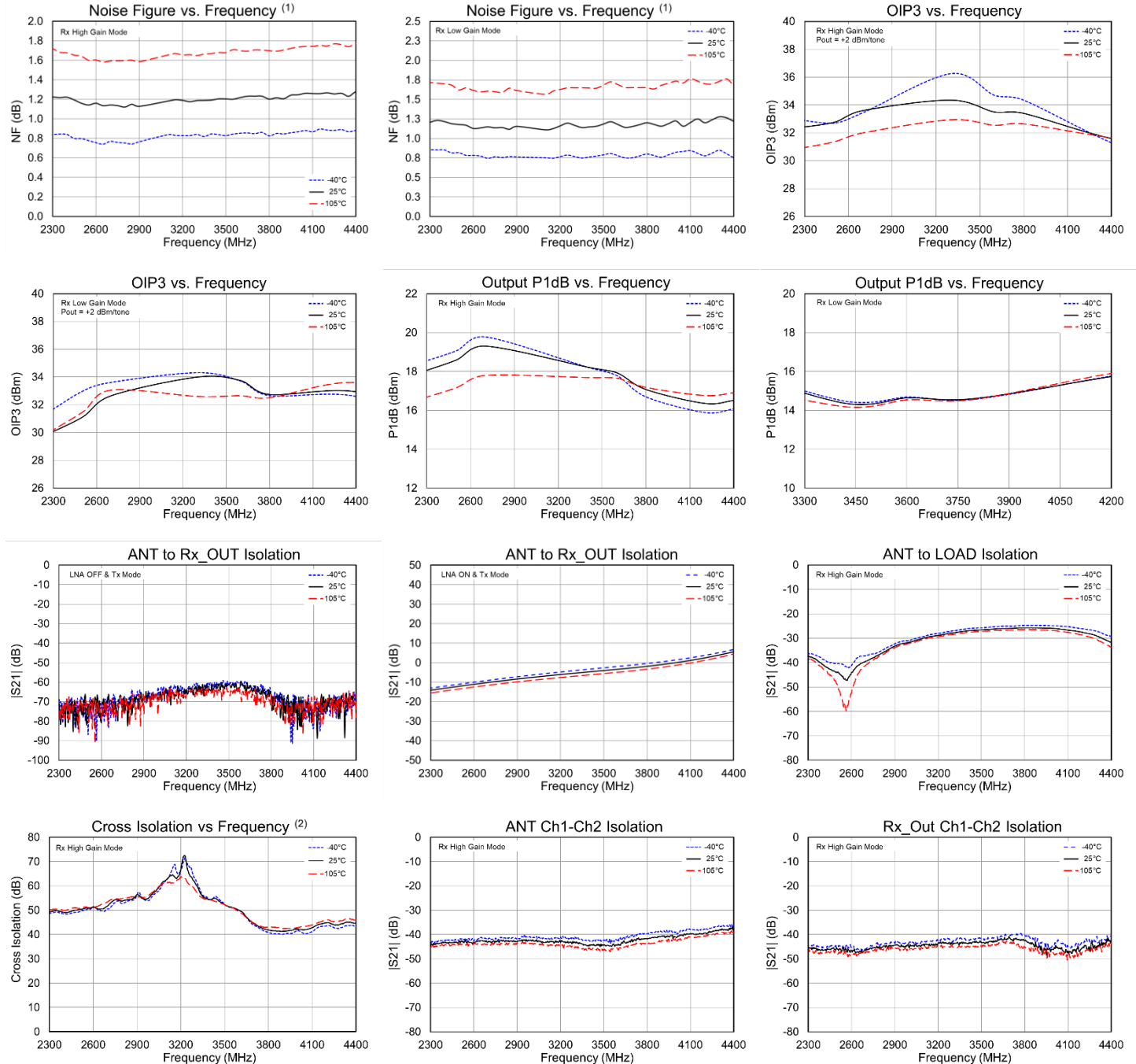

- Notes:
- Trace loss de-embedded from Noise Figure data.
 - Cross Isolation is defined as S21-S41 or S43-S23, where Port 1 is ANT_ChA, Port 2 is Rx_Out_ChA, Port3 is ANT_ChB and Port4 is Rx_Out_ChB.

Performance Plots – QPB9378EVB-01 (Continued)

Test conditions unless otherwise noted: $V_{DD} = +5\text{ V}$.

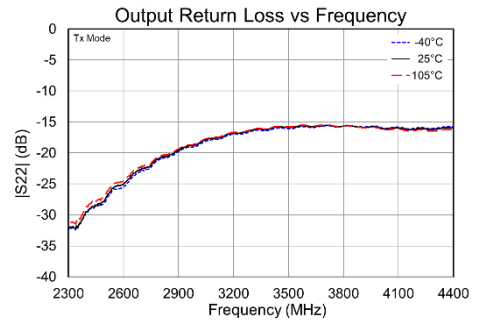
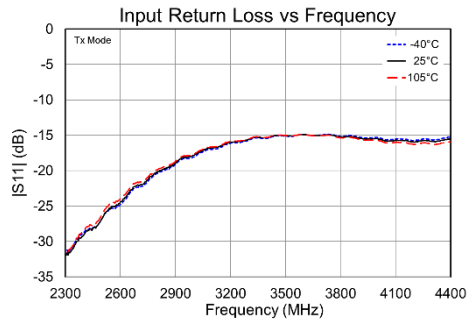
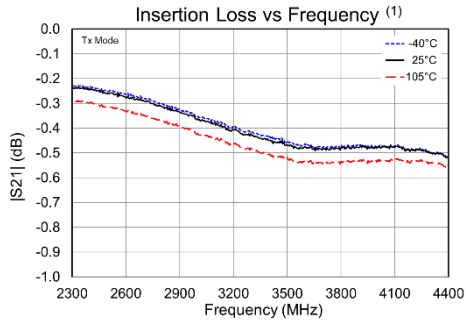

Notes:

1. Trace loss de-embedded from Insertion Loss data.

Bill of Material – QPB9378EVB-02 (4400 – 5000 MHz)

Reference Des.	Value	Description	Manuf.	Part Number
U1		2.3-5GHz 20W Switch-LNA Module	Qorvo	QPB9378
L10	2 pF	CAP, ±0.1pF, 25V, C0G, HIQ, 0201	Murata	GJM0335C1E2R0BB01D
C23	10 pF	CAP, 5%, 50V, HI-Q, 0402	Murata	GJM1555C1H100JB01D
C5, C17	0.2 pF	CAP, +/-0.1pF, 25V, HI-Q, 0201	Murata	GJM0335C1ER20BB01D
L7, L11	0.8 pF	CAP, +/-0.1pF, 25V, HI-Q, 0201	Murata	GJM0335C1ER80BB01D
L5, L16	3 pF	CAP, +/-0.1pF, 25V, HI-Q, 0201	Murata	GJM0335C1E3R0BB01D
L14	1.5 pF	CAP, +/-0.25pF, 25V, C0G, 0201	Murata	GRM0335C1E1R5CA01D
C8, C10, C12	100 pF	CAP, 5%, 25V, C0G, 0201	Murata	GRM0335C1E101JA01D
C9	0.1 uF	CAP, 10%, 10V, X7R, 0201	Murata	GRM033Z71A104KE14D
C1, C2, C18, C19, C21, C22, C24, C25, C26	1 uF	CAP, 10%, 6.3V, X7R, 0402	Murata	GRM155R70J105KA12D
C11	10 pF	CAP, 5%, 25V, C0G, 0201	Yageo	CC0201JRNPO8BN100
C28	4700 pF	CAP, 10%, 100V, X7S, 0402	TDK	C1005X7S2A472K050BB
C3, C4, C15, C16, C28	100 pF	Cap, 5%, 50V, NP0, 0402	Various	
C20, C27	1000 pF	CAP, 10%, 50V, X7R, 0402	Johanson	500R07W102KV4T
L1, L2, L3, L4, L9, L13	0 Ω	JMPR, 0 OHM, 0201	Kamaya	RMC1/20JPPA15
C6, C13	4.3 nH	IND, 3%, 0.35A, HI-Q, 0201	Murata	LQP03TN4N3H02D
C7, C14	10 nH	IND, 3%, M/L, MID-Q, 0201	TDK	MLG0603P10NHT000

Typical Performance – QPB9378EVB-02 (4400 – 5000 MHz)

Test conditions unless otherwise noted: $V_{DD} = +5\text{ V}$, Temp = $+25^\circ\text{C}$

Parameter	Conditions	Typical Values			Units
Frequency		4400	4900	5000	MHz
Gain, Channel A	Rx High Gain Mode	36.5	39.5	39.5	dB
Gain, Channel B		38.1	42.5	42.1	dB
Input RL		13.0	15.0	11.8	dB
Output RL		10.8	13.4	12.8	dB
Noise Figure ⁽¹⁾		1.45	1.44	1.47	dB
OIP3 ⁽²⁾		31.3	30.6	30.6	dBm
Input P1dB		16.6	16.2	16.3	dBm
Cross Isolation		42.4	38.3	39.3	dB
Insertion Loss ⁽¹⁾	Tx Mode	0.5	0.5	0.5	dB
Input Return Loss		16.5	27.5	23.9	dB
Output Return Loss		16.9	23.1	21.8	dB

Notes:

1. Input trace loss de-embedded from NF and IL data.
2. Pout/tone = +2 dBm, $\Delta f = 1\text{ MHz}$

Performance Plots – QPB9378EVB-02 (4400 – 5000 MHz)

Test conditions unless otherwise noted: $V_{DD} = +5\text{ V}$.

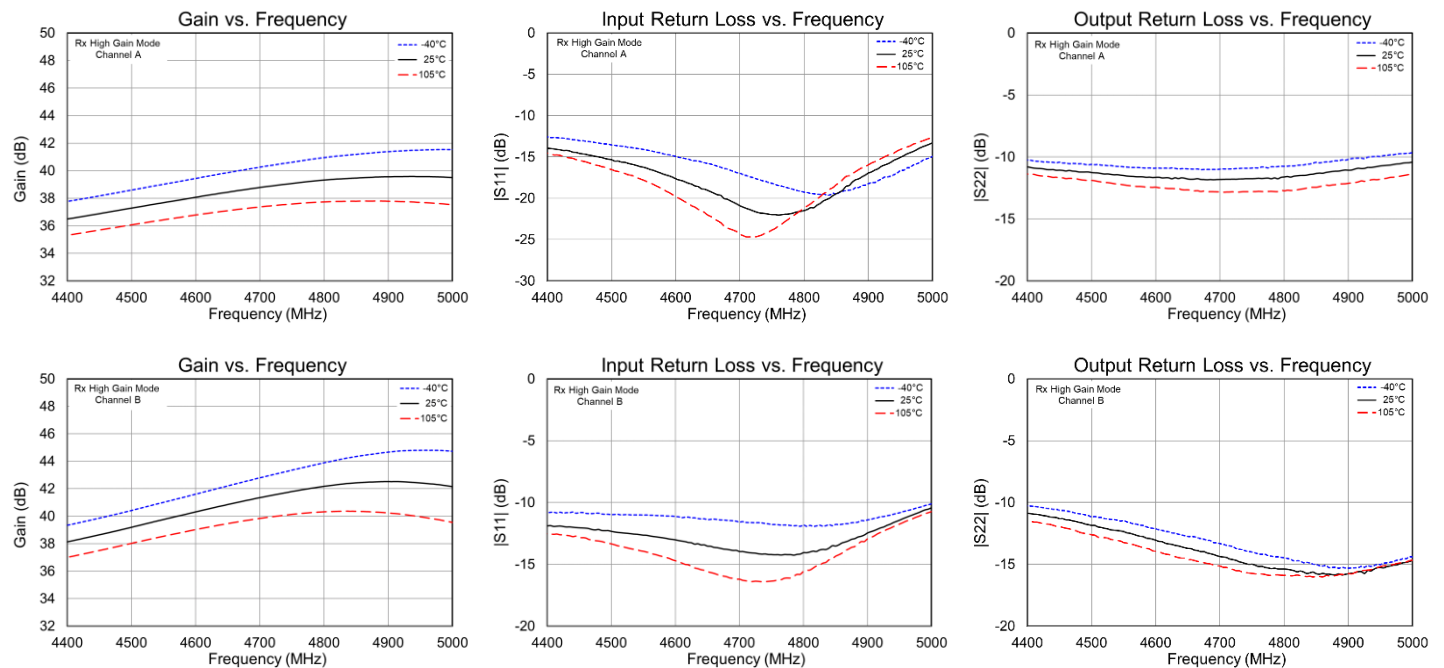

Performance Plots – QPB9378EVB-02 (4400 – 5000 MHz) Continued

Test conditions unless otherwise noted: $V_{DD} = +5\text{ V}$.

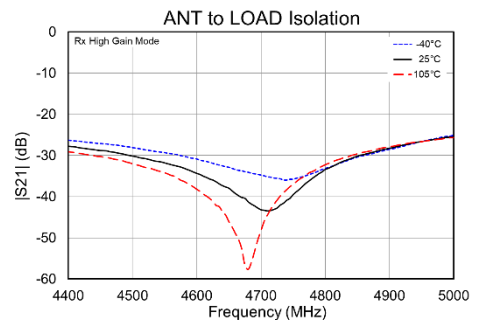
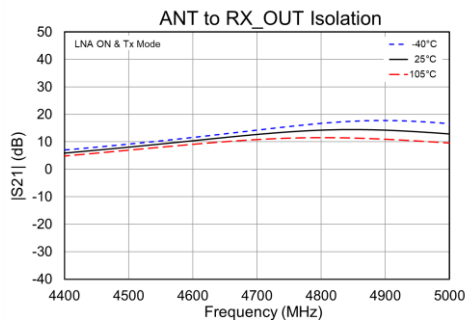
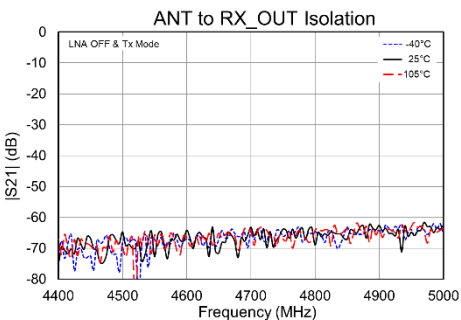
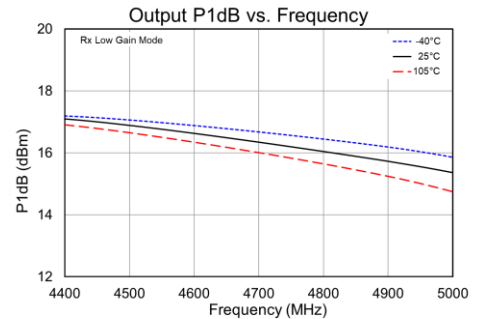
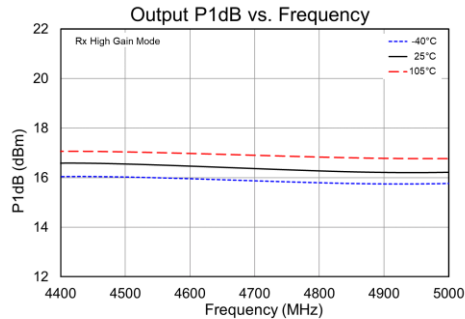
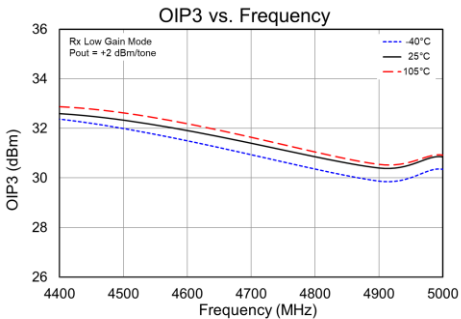
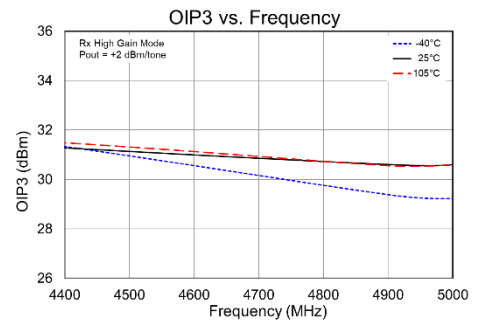
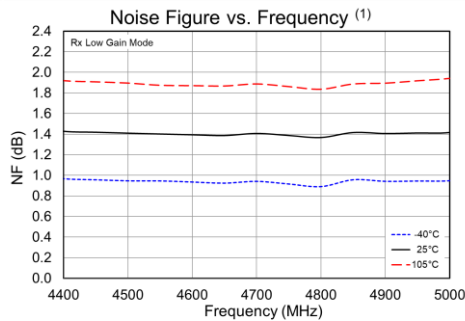
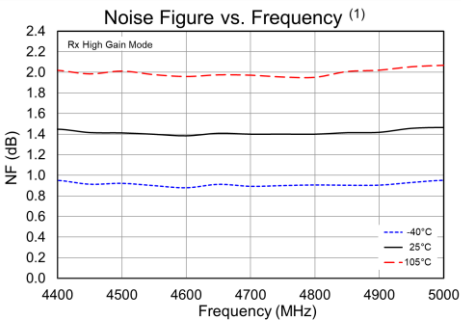
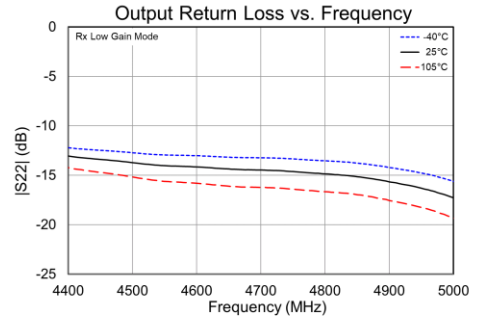
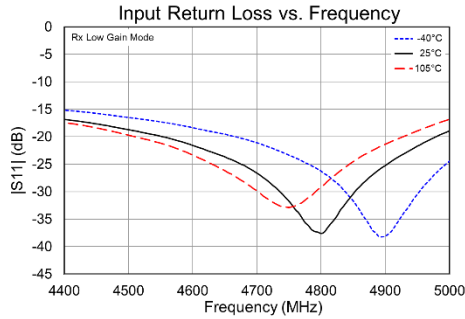
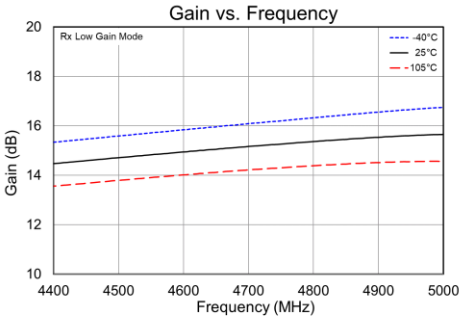

Notes:

- Trace loss de-embedded from Noise Figure data.

Performance Plots – QPB9378EVB-02 (4400 – 5000 MHz) Continued

Test conditions unless otherwise noted: $V_{DD} = +5\text{ V}$.

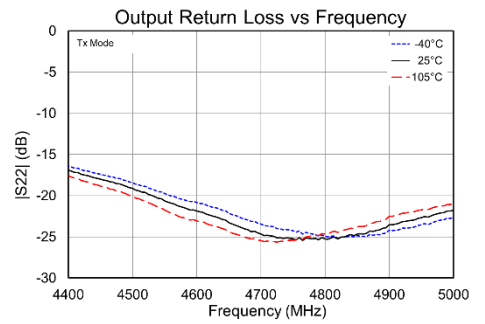
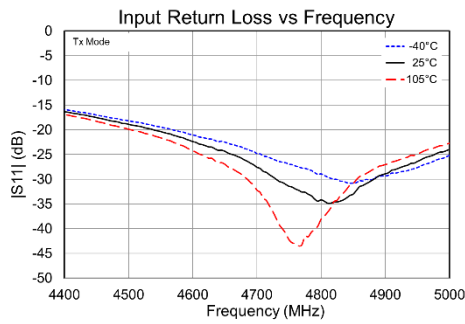
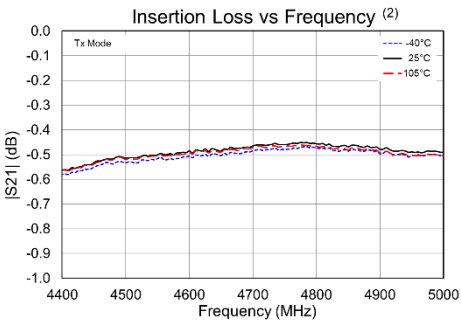
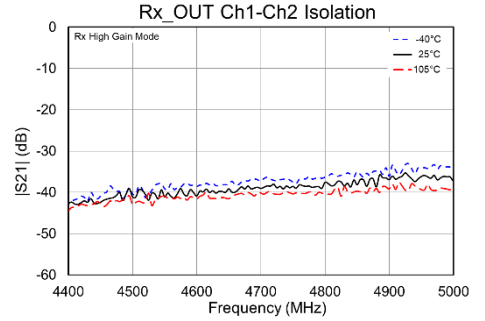
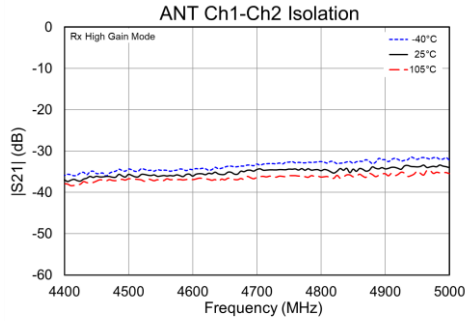
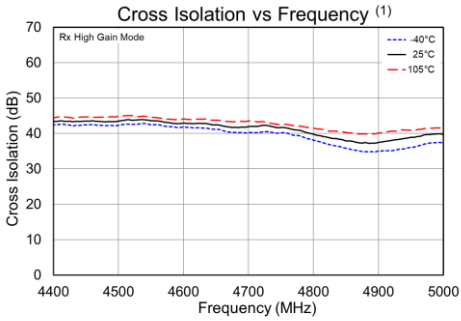

- Notes:
1. Cross Isolation is defined as S21-S41 or S43-S23, where Port 1 is ANT_ChA, Port 2 is Rx_Out_ChA, Port3 is ANT_ChB and Port4 is Rx_Out_ChB.
 2. Trace loss de-embedded from Insertion Loss data.

Pad Configuration and Description

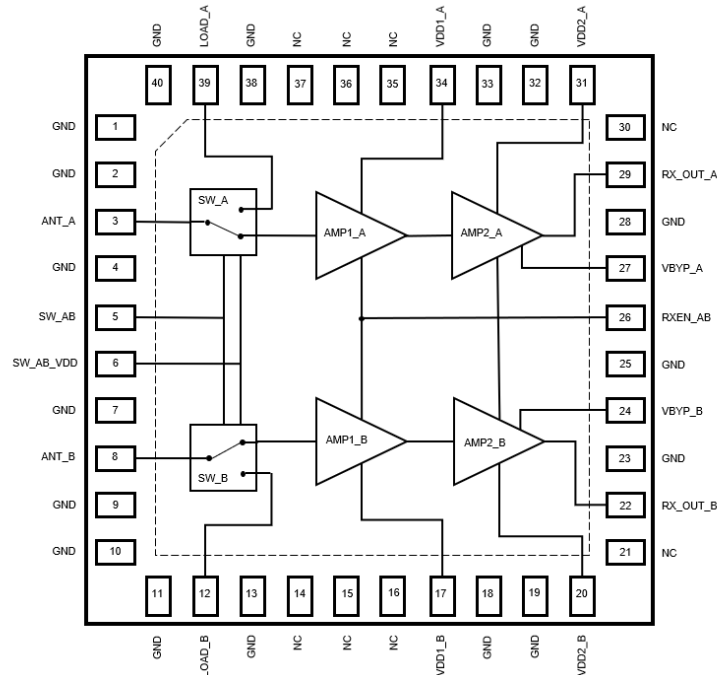

Top View

Pad No.	Label	Description
1, 2, 4, 7, 9, 10, 11, 13, 18, 19, 23, 25, 28, 32, 33, 38, 40	GND	Internally connected to ground, can be left no connection, or connect to ground externally.
14, 15, 16, 21, 30, 35, 36, 37	NC	Internally not connected to ground, can be left no connection, or connect to ground externally
3	ANT_A	RF Input, Antenna port of switch, Channel A
5	SW_AB	Control input, Switching path to Rx or Tx, both channel A & B
6	SW_AB_VDD	DC supply voltage input, Tx-Rx switches, both channel A & B
8	ANT_B	RF Input, Antenna port of switch, Channel B
12	LOAD_B	RF output, Tx termination, Channel B
17	VDD1_B	DC supply voltage input, First stage LNA, Channel B
20	VDD2_B	DC supply voltage input, Second stage LNA, Channel B
22	RX_OUT_B	RF output, Rx, Channel B
24	VBYP_B	Control input, Second LNA bypass, Channel B
26	RXEN_AB	Control input, LNA shutdown, both Channel A & B
27	VBYP_A	Control input, Second LNA bypass, Channel A
29	RX_OUT_A	RF output, Rx, Channel A
31	VDD2_A	DC supply voltage input, Second stage LNA, Channel A
34	VDD1_A	DC supply voltage input, First stage LNA, Channel A
39	LOAD_A	RF output, Tx termination, Channel A
Backside Pad	GND	Ground connection. The back side of the package should be connected to the ground plane. PCB via holes under the device are recommended.

Package Marking and Dimensions

Marking: Pin 1 Indicator and Qorvo Logo
Part Number – QPB9378
Trace Code – Assigned by sub-contractor

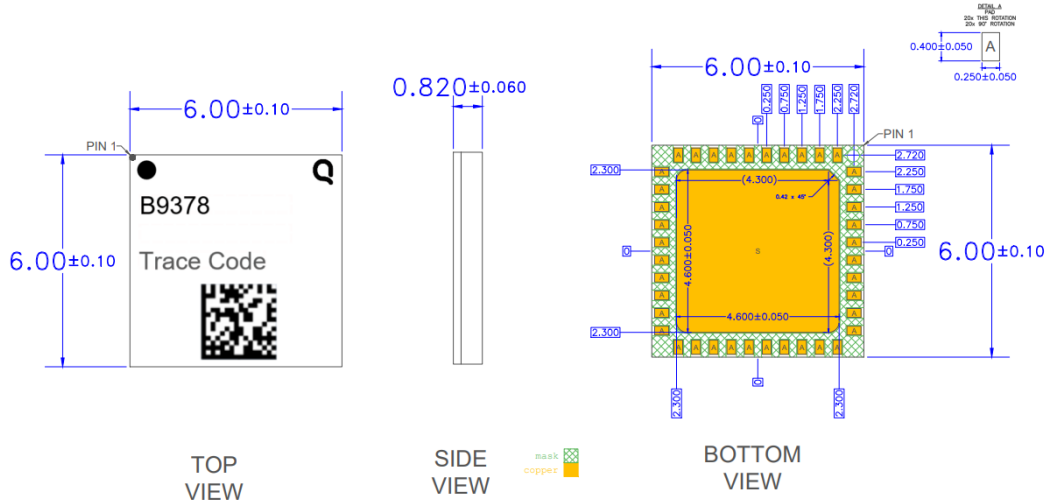

- Notes:
1. All dimensions are in millimeters. Angles are in degrees.
 2. The terminal #1 identifier and terminal numbering conform to SPE-000677.
 3. Contact plating: ENEPIG

Recommended PCB Layout Pattern

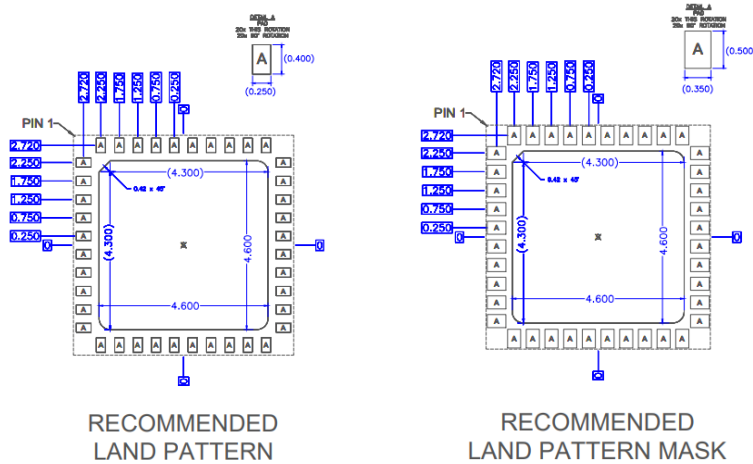

- Notes:
1. All dimensions are in millimeters. Angles are in degrees.
 2. Use 1 oz. copper minimum for top and bottom layer metal.
 3. Via holes are required under the backside paddle of this device for proper RF/DC grounding and thermal dissipation. We recommend a 0.35mm (#80/.0135") diameter bit for drilling via holes and a final plated thru diameter of 0.25 mm (0.01").
 4. Ensure good package backside paddle solder attach for reliable operation and best electrical performance.

Tape and Reel Information – Carrier and Cover Tape Dimensions

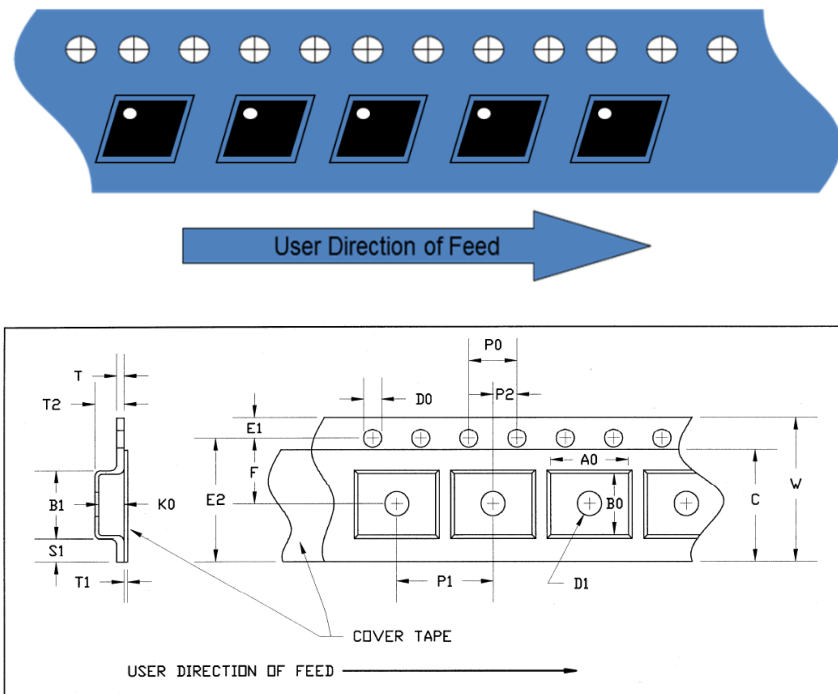

Feature	Measure	Symbol	Size (in)	Size (mm)
Cavity	Length	A0	0.250	6.35
	Width	B0	0.250	6.35
	Depth	K0	0.072	1.83
	Pitch	P1	0.472	12.00
Centerline Distance	Cavity to Perforation - Length Direction	P2	0.079	2.00
	Cavity to Perforation - Width Direction	F	0.295	7.50
Cover Tape	Width	C	0.524	13.3
Carrier Tape	Width	W	0.630	16.0

Tape and Reel Information – Reel Dimensions

Standard T/R size = 2500 pieces on a 13” reel.

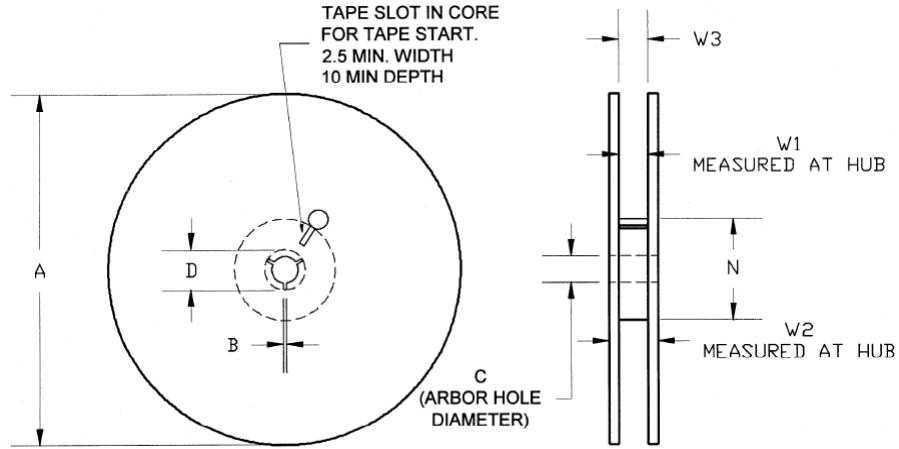

Feature	Measure	Symbol	Size (in)	Size (mm)
Flange	Diameter	A	12.992	330.0
	Thickness	W2	0.874	22.2
	Space Between Flange	W1	0.661	16.8
Hub	Outer Diameter	N	4.016	102.0
	Arbor Hole Diameter	C	0.512	13.0
	Key Slit Width	B	0.079	2.0
	Key Slit Diameter	D	0.787	20.0

Tape and Reel Information – Tape Length and Label Placement

Tape and reel specifications for this part are also available on the Qorvo website.
Standard T/R size = 2500 pieces on a 13” reel.

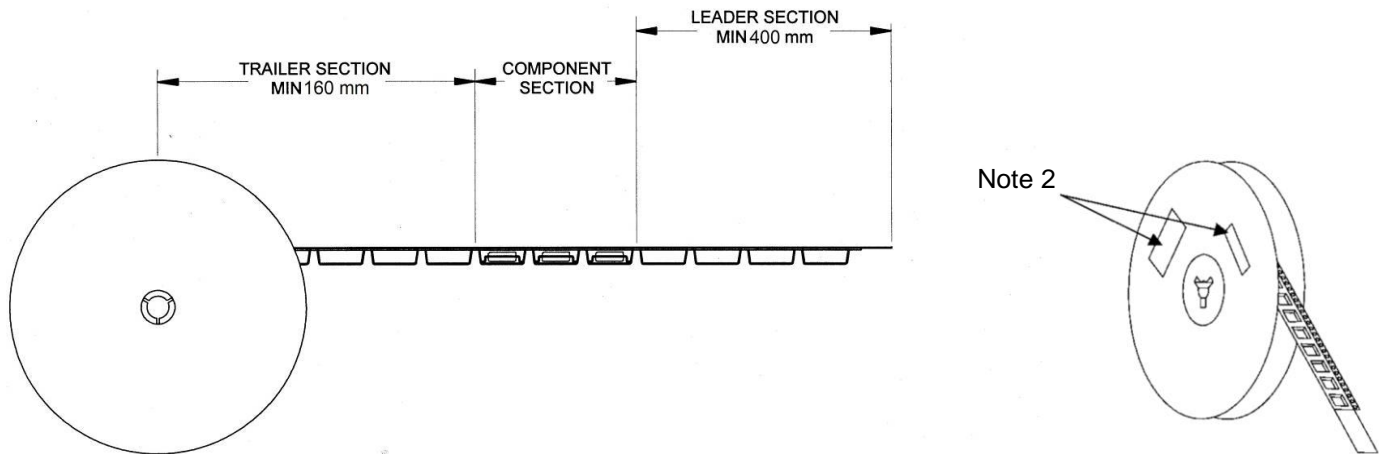

Notes:

1. Empty part cavities at the trailing and leading ends are sealed with cover tape. See EIA 481.
2. Labels are placed on the flange opposite the sprockets in the carrier tape.

Handling Precautions

Parameter	Rating	Standard
ESD – Human Body Model (HBM)	Class 1C	ESDA / JEDEC JS-001-2017
ESD – Charged Device Model (CDM)	Class C3	JEDEC JESD22-C101F
MSL – Moisture Sensitivity Level	Level 3	IPC/JEDEC J-STD-020E



Caution!
ESD-Sensitive Device

Solderability

Compatible with both lead-free (260°C max. reflow temperature) and tin/lead (245°C max. reflow temperature) soldering processes. Solder profiles available upon request.

Contact plating: ENEPIG (*Ni 0.40 ±0.10 μm, Pd 0.145 ±0.035 μm, Au 0.095 ±0.025 μm*)

RoHS Compliance

This part is compliant with 2011/65/EU RoHS directive (Restrictions on the Use of Certain Hazardous Substances in Electrical and Electronic Equipment) as amended by Directive 2015/863/EU.

This product also has the following attributes:

- Halogen Free (Chlorine, Bromine)
- Antimony Free
- TBBP-A (C₁₅H₁₂Br₄O₂) Free
- PFOS Free
- SVHC Free

Contact Information

For the latest specifications, additional product information, worldwide sales and distribution locations:

Web: www.qorvo.com

Tel: 1-844-890-8163

Email: customer.support@qorvo.com

Important Notice

The information contained herein is believed to be reliable; however, Qorvo makes no warranties regarding the information contained herein and assumes no responsibility or liability whatsoever for the use of the information contained herein. All information contained herein is subject to change without notice. Customers should obtain and verify the latest relevant information before placing orders for Qorvo products. The information contained herein or any use of such information does not grant, explicitly or implicitly, to any party any patent rights, licenses, or any other intellectual property rights, whether with regard to such information itself or anything described by such information. **THIS INFORMATION DOES NOT CONSTITUTE A WARRANTY WITH RESPECT TO THE PRODUCTS DESCRIBED HEREIN, AND QORVO HEREBY DISCLAIMS ANY AND ALL WARRANTIES WITH RESPECT TO SUCH PRODUCTS WHETHER EXPRESS OR IMPLIED BY LAW, COURSE OF DEALING, COURSE OF PERFORMANCE, USAGE OF TRADE OR OTHERWISE, INCLUDING THE IMPLIED WARRANTIES OF MERCHANTABILITY AND FITNESS FOR A PARTICULAR PURPOSE.**

Without limiting the generality of the foregoing, Qorvo products are not warranted or authorized for use as critical components in medical, life-saving, or life-sustaining applications, or other applications where a failure would reasonably be expected to cause severe personal injury or death.

Copyright 2022 © Qorvo, Inc. | Qorvo is a registered trademark of Qorvo, Inc.

Looking for pricing, stock, or lifecycle information?

Click below to explore more details on WIN SOURCE:

 [View QPB9378TR13 on WIN SOURCE](#)

 [Qorvo US Inc. Information](#)

Optimize Your Supply Chain with WIN SOURCE Solutions

-  Global Sourcing Solution
-  Obsolete Management
-  Cost Control Management
-  Shortage Management
-  Alternative Solution
-  Excess Inventory Management