



THE DATASHEET OF
5962-86716012A



HI-201HS/883

High Speed Quad SPST CMOS Analog Switch

FN8265
Rev.0.00
April 9, 2012

The HI-201HS/883 is a monolithic CMOS analog switch featuring very fast switching speeds and low ON resistance. This integrated circuit consists of four independently selectable SPST switches and is pin compatible with the industry standard HI-201 switch.

Fabricated using silicon-gate technology and the Intersil dielectric isolation process, this TTL compatible device offers improved performance over previously available CMOS analog switches while eliminating the problem of latch-up associated with other fabrication processes. Featuring maximum switching times of 50ns, low ON resistance of 50Ω maximum, and a wide analog signal range, the HI-201HS/883 is designed for any military application where improved switching performance, particularly switching speed, is required. (A more detailed discussion on the design and application of the HI-201HS/883 can be found in Application Note [AN543](#).)

The HI-201HS/883 is available in a 16 Ld CerDIP package and is specified over the temperature range of -55 °C to +125 °C.

Features

- This Circuit is Processed in Accordance to MIL-STD-883 and is Fully Conformant Under the Provisions of Paragraph 1.2.1.
- Low “On” Release 50Ω Max
- Wide Analog Signal Range ±15V
- Turn-On Time 50ns
- Analog Current Range (Continuous) 25mA
- TTL/CMOS Compatible
- No Latch-Up
- Pin Compatible with Standard HI-201

Applications

- High Speed Multiplexing
- High Frequency Analog Switching
- Sample and Hold Circuits
- Digital Filters
- Op Amp Gain Switching Networks
- Integrator Reset Circuits

Pin Configuration

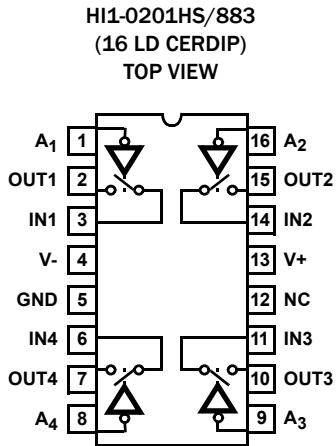

TRUTH TABLE

LOGIC	SWITCH
0	ON
1	OFF

Functional Diagram

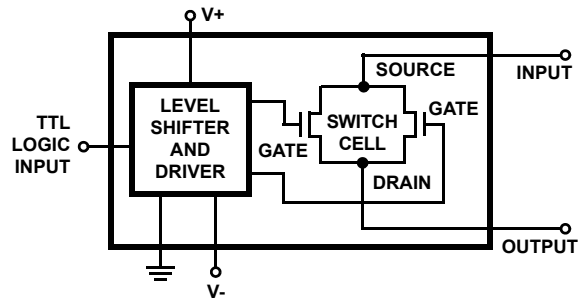

Ordering Information

PART NUMBER	PART MARKING	TEMP. RANGE (°C)	PACKAGE	PKG. DWG. #
HI1-0201HS/883	HI1-201HS/883	-55 to +125	16 Ld CerDIP	F16.3

Absolute Maximum Ratings

Voltage Between V+ and V- Terminals	36V
$\pm V_{SUPPLY}$ to Ground (V+, V-)	$\pm 18V$
Analog Input Voltage, (+V _S)	+V _{SUPPLY} +2V
(-V _S)	-V _{SUPPLY} -2V
Digital Input Voltage, (+V _A)	+V _{SUPPLY} +4V
(-V _A)	-V _{SUPPLY} -4V
Peak Current (S or D) (Pulse at 1ms, 10% Duty Cycle Max)	50mA
Continuous Current Any Terminal (Except S or D)	25mA

Thermal Information

Thermal Resistance	θ_{JA} (°C/W)	θ_{JC} (°C/W)
CerDIP Package	75	16
Package Power Dissipation at +75°C		
CerDIP Package	1.0W	
Package Power Dissipation Derating Factor above +75°C		
CerDIP Package	13.36mW/°C	
Junction Temperature	+175°C	
Storage Temperature Range	-65°C to +150°C	
Lead Temperature (Soldering 10s)	≤275°C	

Recommended Operating Conditions

Operating Temperature Range	-55°C to +125°C
Operating Supply Voltage Range ($\pm V_{SUPPLY}$)	$\pm 15V$
Analog Input Voltage (V _S)	$\pm V_{SUPPLY}$
Logic Low Level (V _{AL})	0V to 0.8V
Logic High Level (V _{AH})	3.0V to +V _{SUPPLY}

CAUTION: Do not operate at or near the maximum ratings listed for extended periods of time. Exposure to such conditions may adversely impact product reliability and result in failures not covered by warranty.

TABLE 1. D.C. ELECTRICAL PERFORMANCE SPECIFICATIONS

Device Tested at: +V_{SUPPLY} = +15V, -V_{SUPPLY} = -15V, GND = 0V, unless otherwise specified.

D.C. PARAMETERS	SYMBOL	CONDITIONS	GROUP A SUBGROUPS	TEMPERATURE (°C)	MIN	MAX	UNITS
Switch "ON" Resistance	r_{DS}	$V_A = 0.8V, V_S = 10V, I_D = -1mA$ All Unused Channels $V_{AL} = 0.8V$	1	+25	-	50	Ω
			2, 3	-55 to +125	-	75	Ω
		$V_A = 0.8V, V_S = -10V, I_D = 1mA$ All Unused Channels $V_{AL} = 0.8V$	1	+25	-	50	Ω
			2, 3	-55 to +125	-	75	Ω
Source "OFF" Leakage Current	$I_{S(OFF)}$	$V_S = +14V, V_D = -14V, V_{AH} = 3.0V$ All Unused Channels $V_{AH} = 3.0V,$ $V_D = +14V, V_S = -14V$	1	+25	-10	10	nA
			2, 3	-55 to +125	-100	100	nA
		$V_S = -14V, V_D = +14V, V_{AH} = 3.0V$ All Unused Channels $V_{AH} = 3.0V,$ $V_D = -14V, V_S = +14V$	1	+25	-10	10	nA
			2, 3	-55 to +125	-100	100	nA
Drain "OFF" Leakage Current	$I_{D(OFF)}$	$V_D = -14V, V_S = +14V, V_{AH} = 3.0V$ All Unused Channels $V_{AH} = 3.0V,$ $V_D = +14V, V_S = -14V$	1	+25	-10	10	nA
			2, 3	-55 to +125	-100	100	nA
		$V_D = +14V, V_S = -14V, V_{AH} = 3.0V$ All Unused Channels $V_{AH} = 3.0V,$ $V_D = -14V, V_S = +14V$	1	+25	-10	10	nA
			2, 3	-55 to +125	-100	100	nA
Channel "ON" Leakage Current	$I_{D(ON)}$	$V_D = V_S = +14V, V_{AL} = 0.8V,$ All Unused Channels $V_{AL} = 0.8V,$ $V_D = V_S = -14V$	1	+25	-10	10	nA
			2, 3	-55 to +125	-100	100	nA
		$V_D = V_S = -14V, V_{AL} = 0.8V,$ All Unused Channels $V_{AL} = 0.8V,$ $V_D = V_S = +14V$	1	+25	-10	10	nA
			2, 3	-55 to +125	-100	100	nA
Low Level Input Current	I_{AL}	$V_{AL} = 0.8V$ All Unused Channels $V_{AH} = 4.0V$	1	+25	-	500	μA
			2, 3	-55 to +125	-	500	μA
High Level Input Current	I_{AH}	$V_{AH} = 4.0V$ All Unused Channels $V_{AL} = 0.8V$	1	+25	-	40	μA
			2, 3	-55 to +125	-	40	μA
Supply Current	$+I_{CC}$	All Channels $V_{AL} = 0.8V$	1, 2	+25, +125	-	10	mA
			3	-55	-	10	mA
		All Channels $V_{AH} = 3.0V$	1, 2	+25, +125	-	10	mA
			3	-55	-	10	mA

TABLE 1. D.C. ELECTRICAL PERFORMANCE SPECIFICATIONS (Continued)

Device Tested at: +V_{SUPPLY} = +15V, -V_{SUPPLY} = -15V, GND = 0V, unless otherwise specified.

D.C. PARAMETERS	SYMBOL	CONDITIONS	GROUP A SUBGROUPS	TEMPERATURE (°C)	MIN	MAX	UNITS
Supply Current	-I _{CC}	All Channels V _{AL} = 0.8V	1, 2	+25, +125	-	6	mA
			3	-55	-	6	mA
		All Channels V _{AH} = 3.0V	1, 2	+25, +125	-	6	mA
			3	-55	-	6	mA

TABLE 2. A.C. ELECTRICAL PERFORMANCE SPECIFICATIONS

Device Tested at: +V_{SUPPLY} = +15V, -V_{SUPPLY} = -15V, GND = 0V, unless otherwise specified.

PARAMETERS	SYMBOL	CONDITIONS	GROUP A SUBGROUPS	TEMPERATURE (°C)	MIN	MAX	UNITS
Turn "ON" Time	t _(ON)	C _L = 35pF, R _L = 1kΩ V _{AH} = 3.0V, V _{AL} = 0.8V	9	+25	-	50	ns
			10, 11	-55, +125	-	100	ns
Turn "OFF" Time	t _(OFF)	C _L = 35pF, R _L = 1kΩ V _{AH} = 3.0V, V _{AL} = 0.8V	9	+25	-	50	ns
			10, 11	-55, +125	-	100	ns

TABLE 3. ELECTRICAL PERFORMANCE SPECIFICATIONS (NOTE 1)

Device Characterized at: +V_{SUPPLY} = +15V, -V_{SUPPLY} = -15V, GND = 0V

PARAMETERS	SYMBOL	CONDITIONS	NOTE	TEMPERATURE (°C)	MIN	MAX	UNITS
Address Capacitance	C _A	f = 1MHz, V _{AL} = 0V	1	+25	-	35	pF
Switch Input Capacitance	C _{S (OFF)}	f = 1MHz, V _{AH} = 5V, Measure Input to GND	1	+25	-	20	pF
Switch Output Capacitance	C _{D (OFF)}	f = 1MHz, V _{AH} = 5V, Measure Output to Ground	1	+25	-	20	pF
	C _{D (ON)}	f = 1MHz, V _{AL} = 0V, Measure Output to Ground	1	+25	-	50	pF
Drain to Source Capacitance	C _{DS}	f = 1MHz, V _{AH} = 5V	1	+25	-	2.0	pF
Off Isolation	V _{ISO}	f = 100kHz, V _A = 3.0, R _L = 1k, V _{GEN} = 1V _{P-P} , C _L = 10pF	1	+25	50	-	dB
Cross Talk	V _{CT}	f = 100kHz, V _A = 3.0, R _L = 1k, V _{GEN} = 1V _{P-P} , C _L = 10pF	1	+25	50	-	dB
Charge Transfer Error	V _{CTE}	R _L = 1k, C _L = 0.01μF	1	+25	-	10	mV

NOTE:

- Parameters listed in Table 3 are controlled via design or process parameters and are not directly tested at final production. These parameters are lab characterized upon initial design release, or upon design changes. These parameters are guaranteed by characterization based upon data from multiple production runs which reflect lot to lot and within lot variation.

TABLE 4. ELECTRICAL TEST REQUIREMENTS

MIL-STD-883 TEST REQUIREMENTS	SUBGROUPS (Tables 1 and 2)
Interim Electrical Parameters (Pre Burn-in)	1
Final Electrical Test Parameters	1 (Note 2), 2, 3, 9, 10, 11
Group A Test Requirements	1, 2, 3, 9, 10, 11
Groups C & D Endpoints	1

NOTE:

- PDA applies to Subgroup 1 only.

Test Circuits

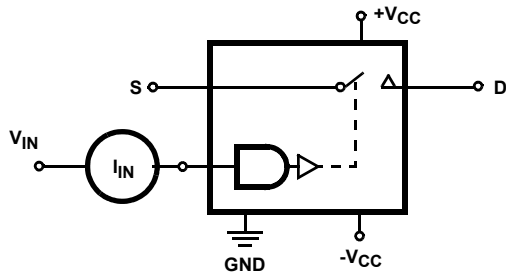

FIGURE 1. INPUT LEAKAGE CURRENT

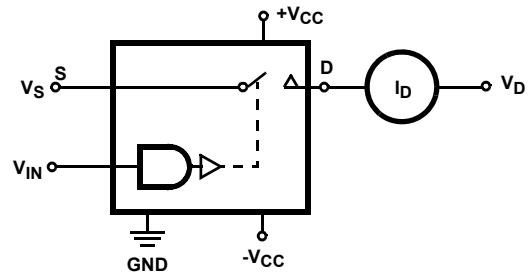

FIGURE 2. $I_{D(OFF)}$

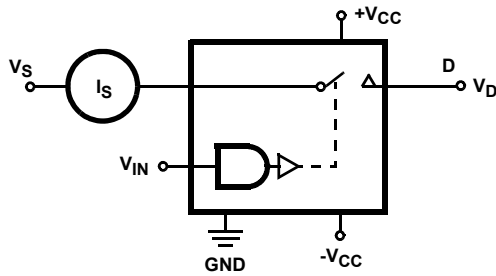

FIGURE 3. $I_{S(OFF)}$

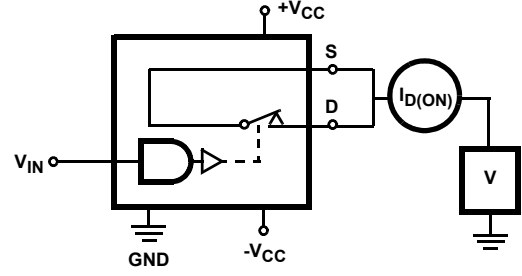

FIGURE 4. $I_{D(ON)}$

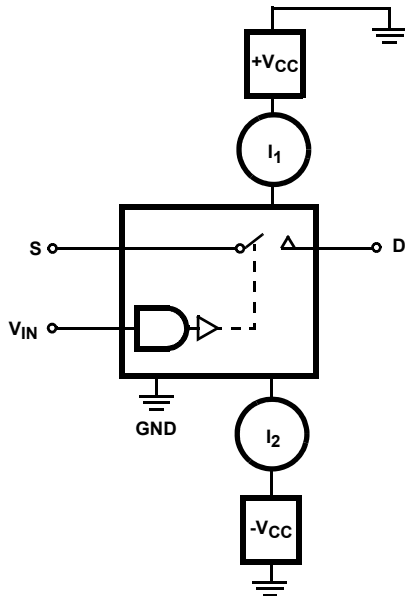
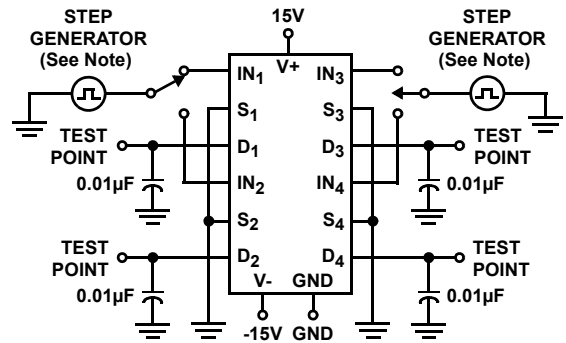

FIGURE 5. SUPPLY CURRENTS



NOTE: The pulse generator has the following characteristics:
 $V_{GEN} = 0V$ to $3V$, rise time $\leq 20ns$, fall time $\leq 20ns$, PRR = $100kHz$.

FIGURE 6. CHARGE TRANSFER ERROR

Test Circuits (Continued)

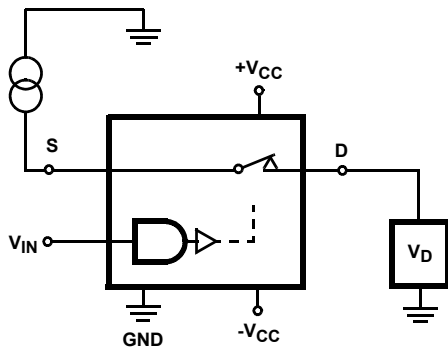
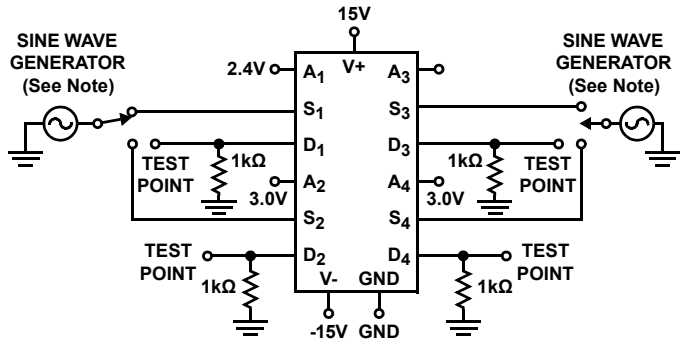
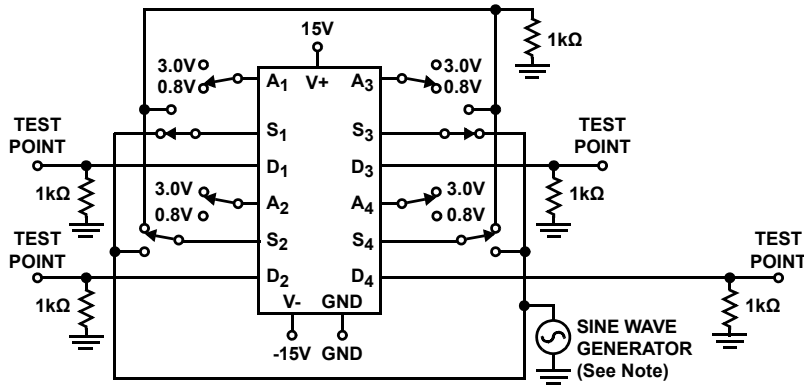

FIGURE 7. R_{DS}



NOTE: The pulse generator has the following characteristics:
 $V_{GEN} = 1V_{p-p}$, Frequency = 100kHz.

FIGURE 8. OFF CHANNEL ISOLATION



NOTE: The pulse generator has the following characteristics: $V_{GEN} = 1V_{p-p}$, Frequency = 100kHz.

FIGURE 9. CROSSTALK BETWEEN CHANNELS

Switching Waveforms

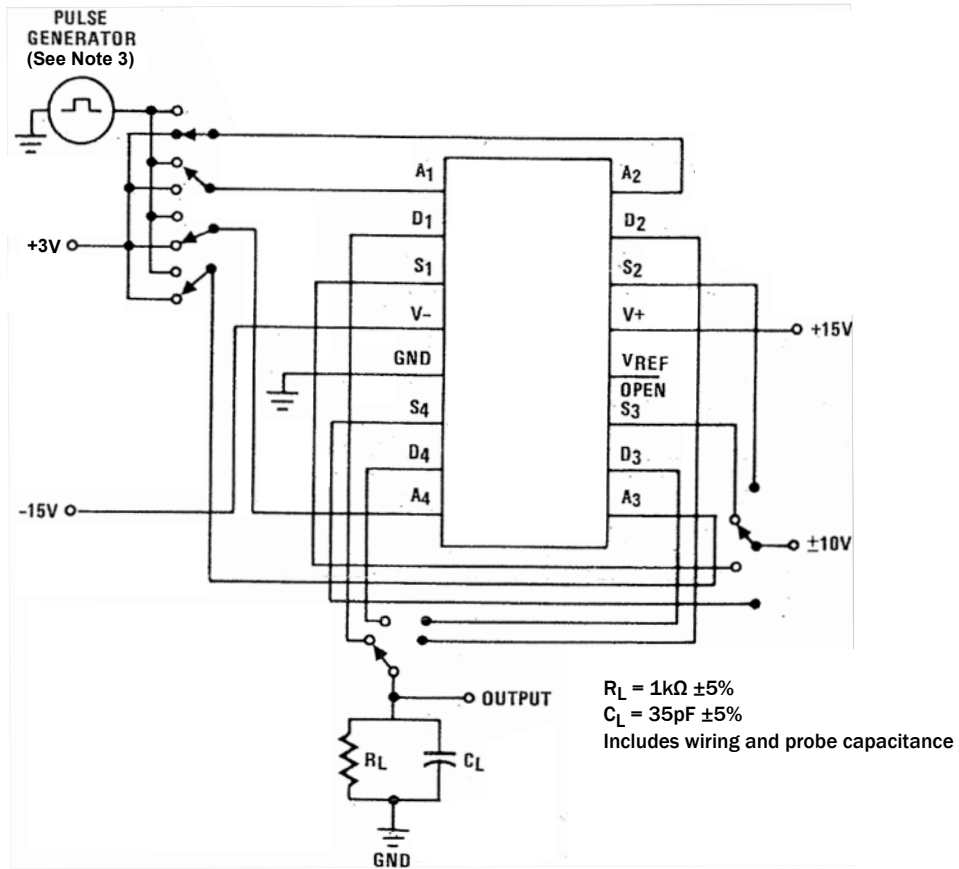

NOTES:

- 3. The pulse generator has the following characteristics:
 $V_{GEN} = 3.0V$, $t_{THL} \leq 20ns$
- 4. See Table 2 for complete terminal conditions

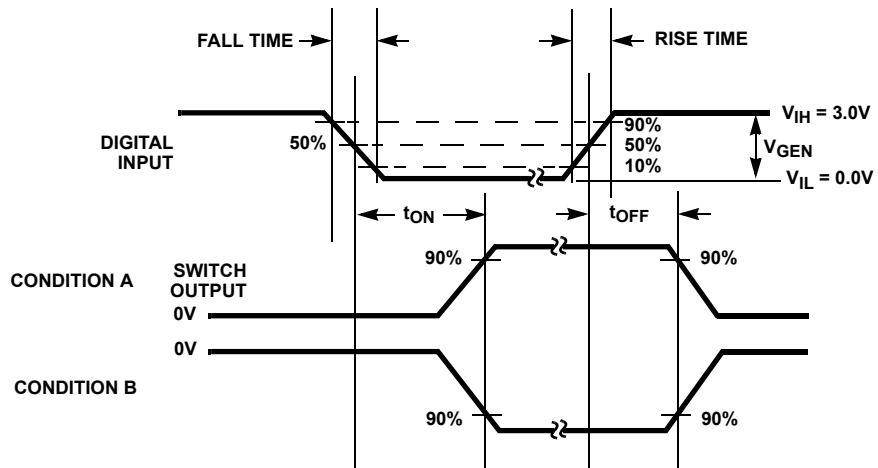

NOTE: Rise time and fall time $\leq 20ns$.

Burn-In Circuit

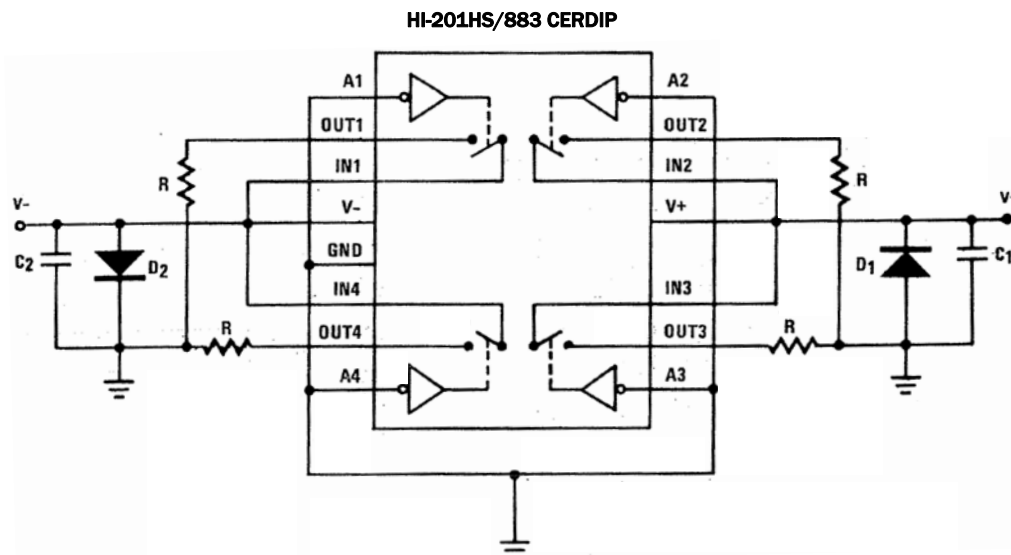

NOTE:

$R = 10k\Omega$, 5%, 1/4W or 1/2W.

$C_1 = C_2 = 0.01\mu F$ (per socket) or $0.1\mu F$ (per row).

$D_1 = D_2 = IN4002$ or equivalent (one per board).

$|(V+) - (V-)| = 30V$.

Schematic Diagrams

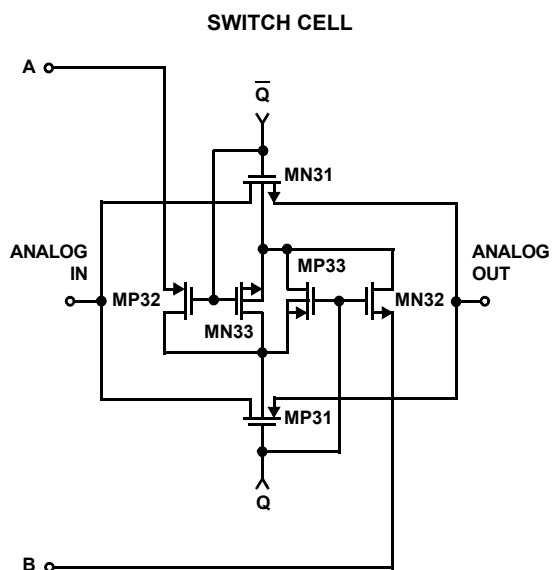

Schematic Diagrams (Continued)

REFERENCE/LEVEL SHIFTER

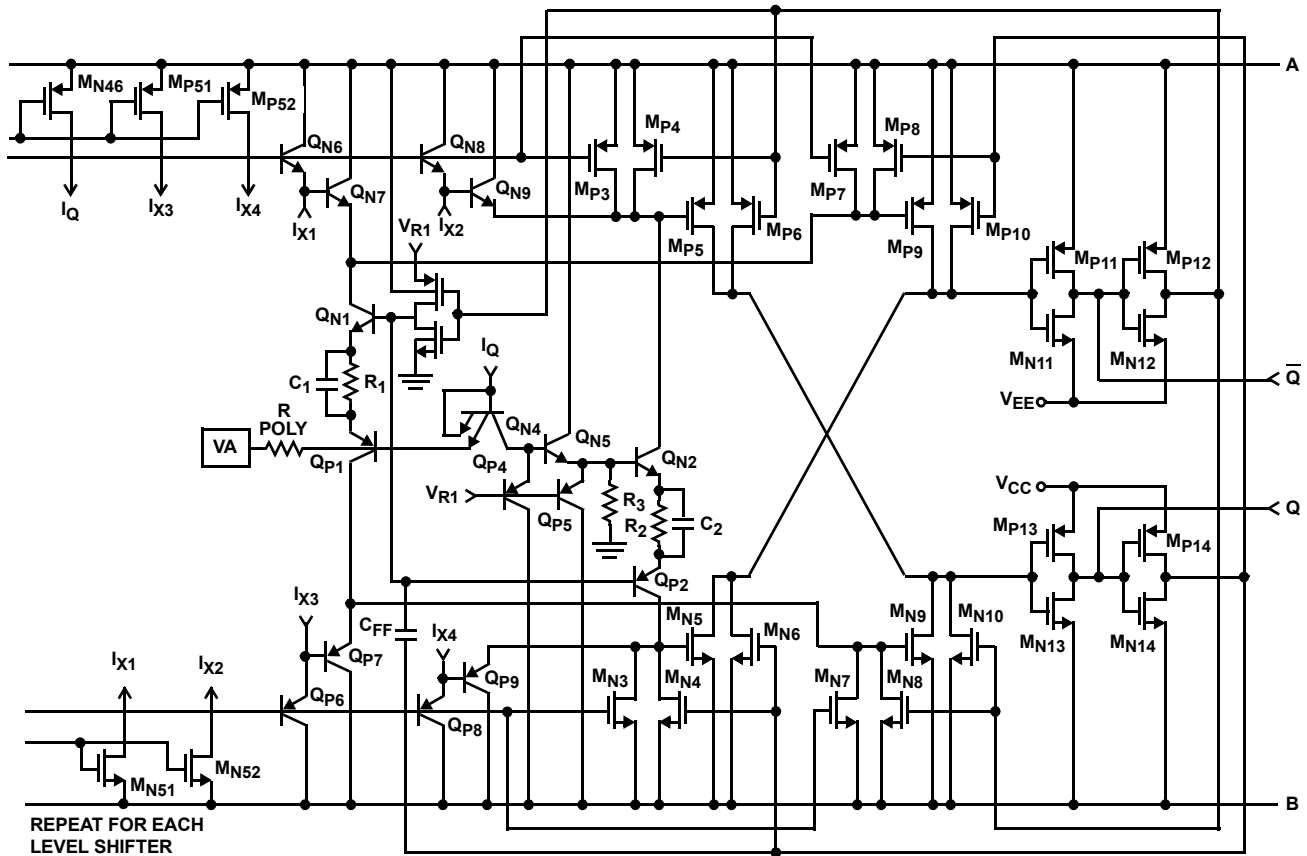
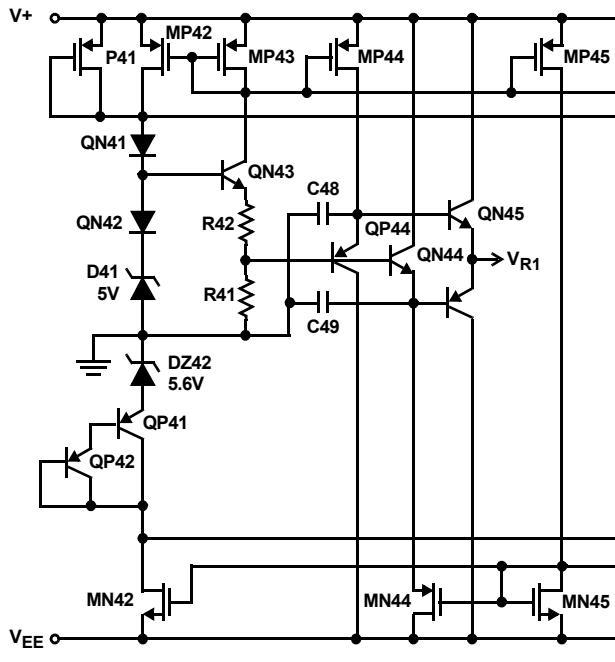

Die Characteristics

DIE DIMENSIONS:

92mils x 111mils x 19mils

METALLIZATION:

Type: Aluminum
Thickness: $16\text{k}\text{\AA} \pm 2\text{k}\text{\AA}$

GLASSIVATION:

Type: Nitride
Nitride Thickness: $7\text{k}\text{\AA} \pm 0.7\text{k}\text{\AA}$

WORST CASE CURRENT DENSITY:

$4.5 \times 10^5 \text{A/cm}^2$ at 25mA

This device meets Glassivation Integrity Test requirement per Mil-Std-883 Method 2021 and Mil-M-38510 paragraph 3.5.5.4.

Metallization Mask Layout

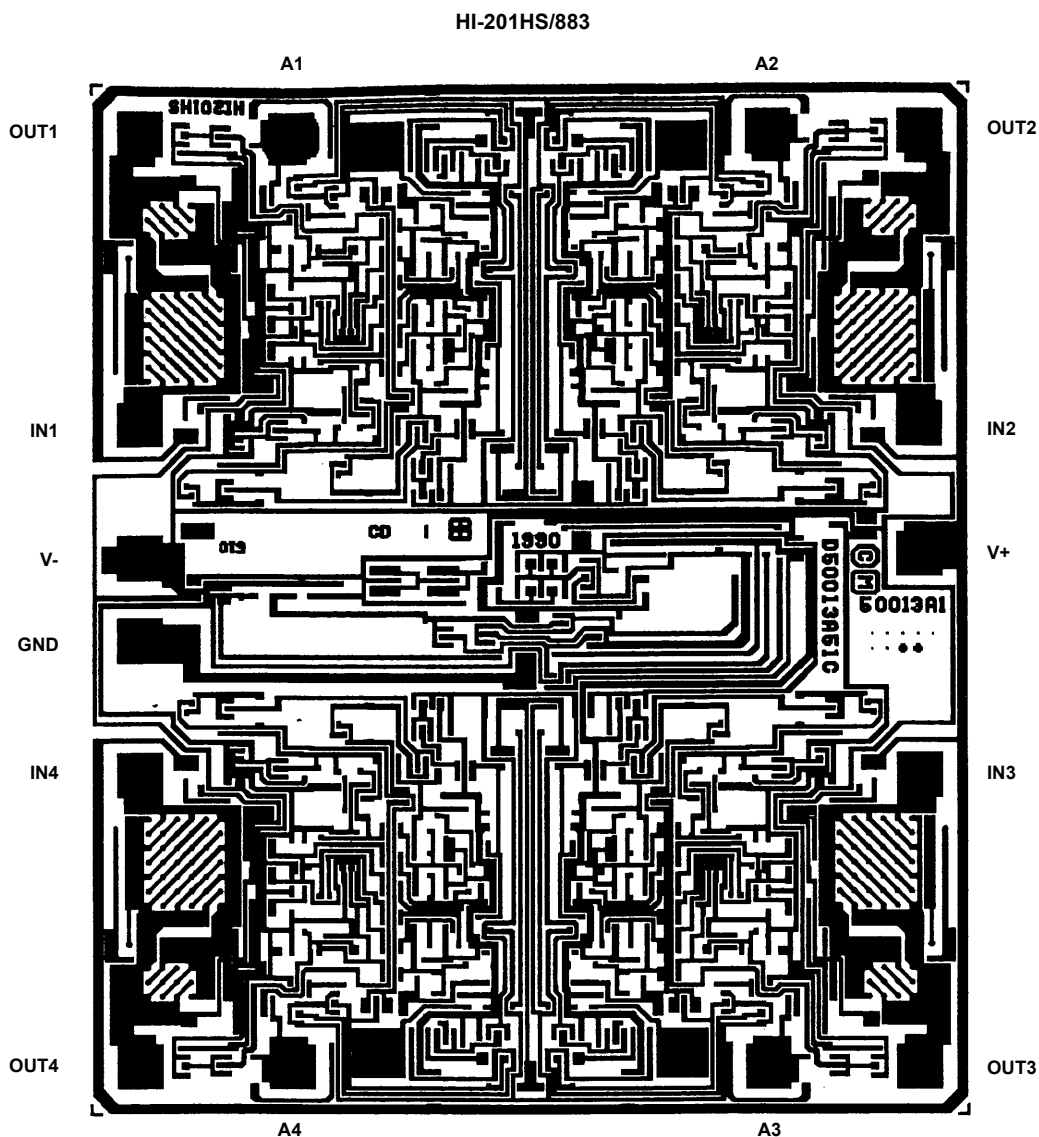

The information contained in this section has been developed through characterization and is for use as application and design information only. No guarantee is implied.

Typical Performance Curves $T_A = +25^\circ\text{C}$, $V_{\text{SUPPLY}} = \pm 15\text{V}$, $V_{\text{AH}} = 3.0\text{V}$, $V_{\text{AL}} = 0.8\text{V}$

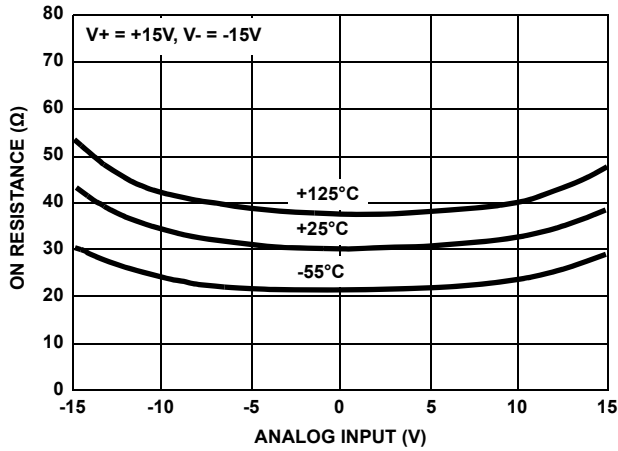

FIGURE 10. ON RESISTANCE vs ANALOG SIGNAL LEVEL AND TEMPERATURE

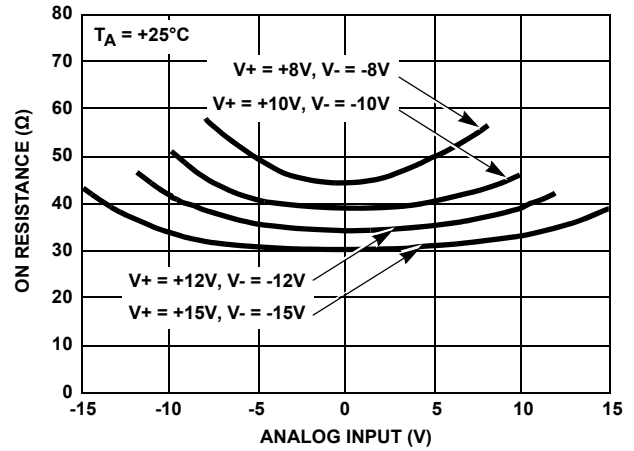

FIGURE 11. ON RESISTANCE vs ANALOG SIGNAL LEVEL AND POWER SUPPLY VOLTAGE

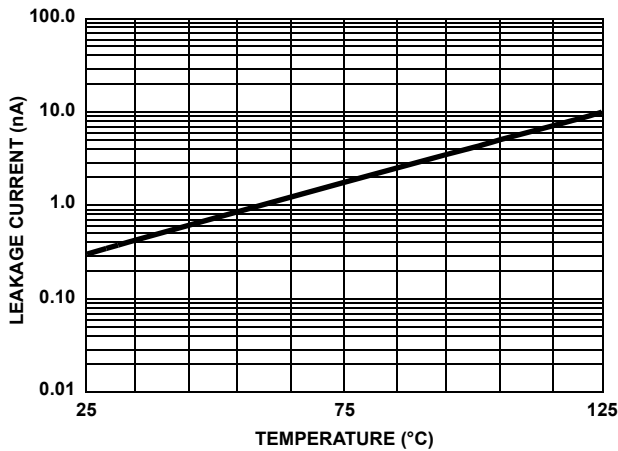

FIGURE 12. $I_{\text{S(OFF)}}$ OR $I_{\text{D(OFF)}}$ vs TEMPERATURE

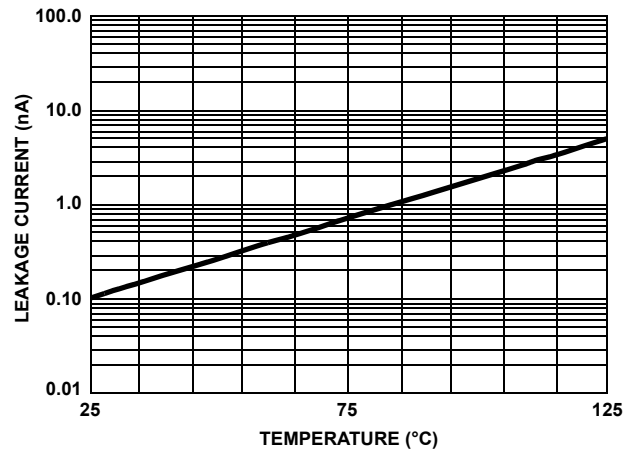

FIGURE 13. $I_{\text{D(ON)}}$ vs TEMPERATURE

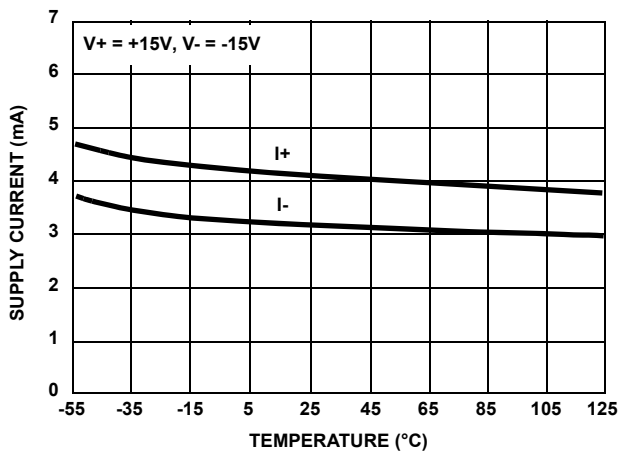

FIGURE 14. SUPPLY CURRENT vs TEMPERATURE

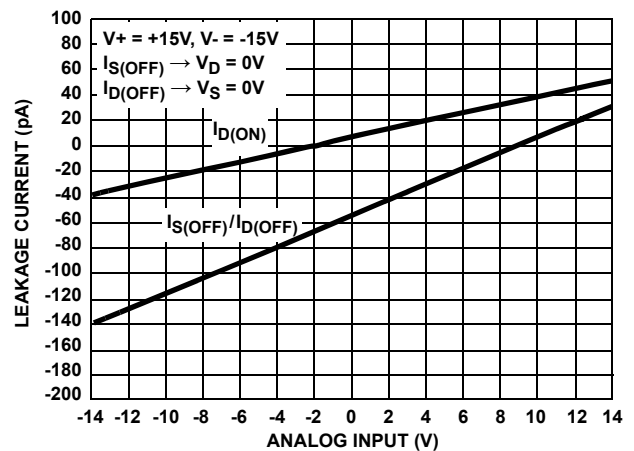

FIGURE 15. LEAKAGE CURRENT vs ANALOG INPUT VOLTAGE

The information contained in this section has been developed through characterization and is for use as application and design information only. No guarantee is implied.

Typical Performance Curves $T_A = +25^\circ\text{C}$, $V_{\text{SUPPLY}} = \pm 15\text{V}$, $V_{\text{AH}} = 3.0\text{V}$, $V_{\text{AL}} = 0.8\text{V}$ (Continued)

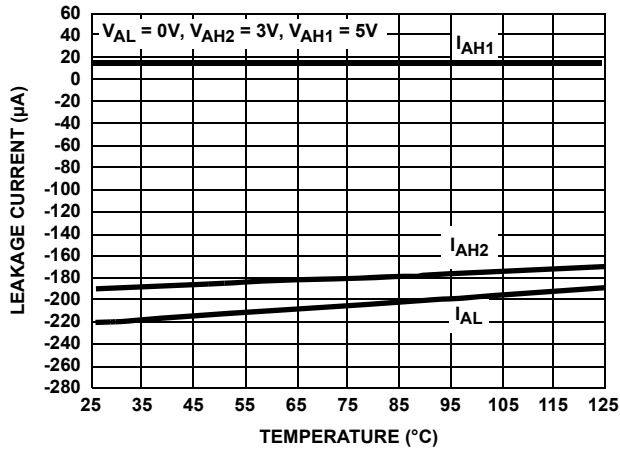

FIGURE 16. DIGITAL INPUT LEAKAGE CURRENT vs TEMPERATURE

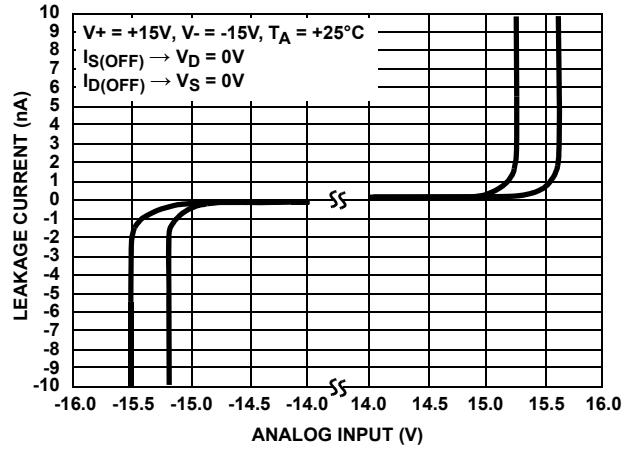

FIGURE 17. LEAKAGE CURRENT vs ANALOG INPUT VOLTAGE

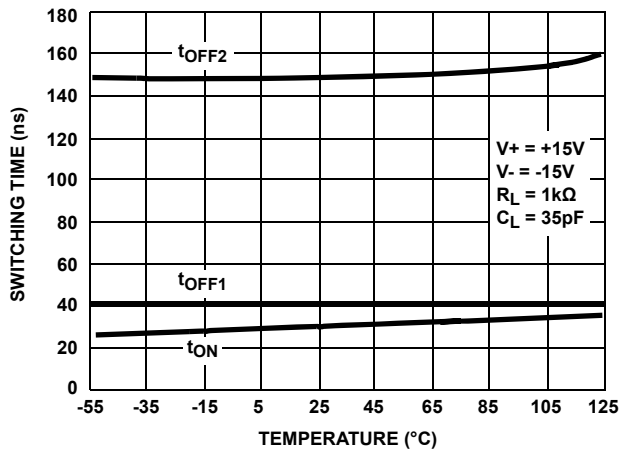

FIGURE 18. SWITCHING TIME vs TEMPERATURE

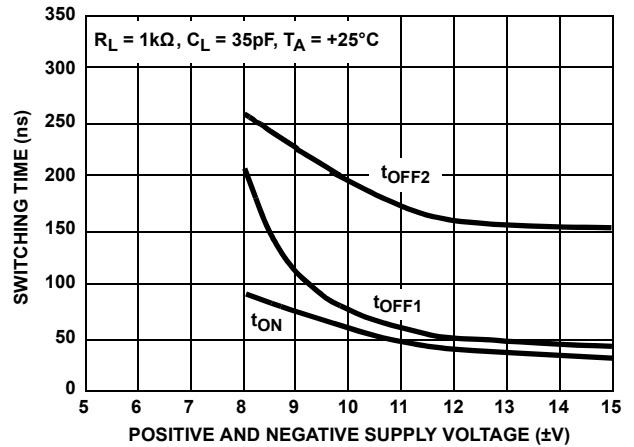

FIGURE 19. SWITCHING TIME vs POSITIVE AND NEGATIVE SUPPLY VOLTAGE

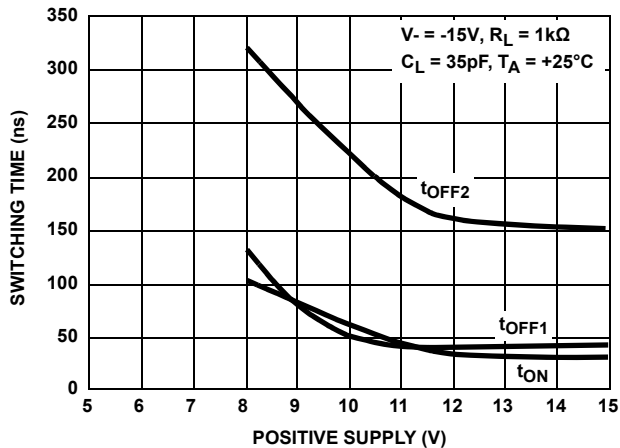

FIGURE 20. SWITCHING TIME vs POSITIVE SUPPLY VOLTAGE

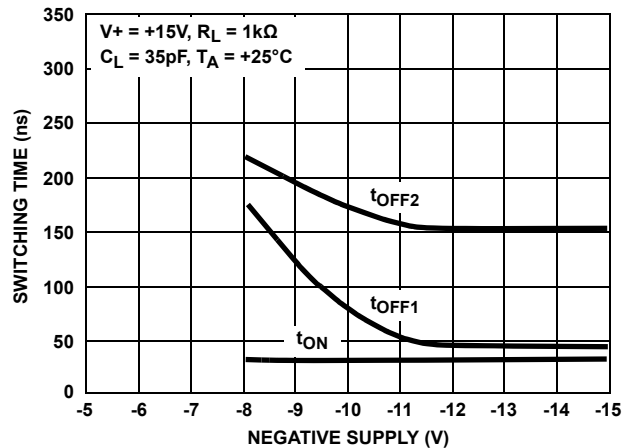

FIGURE 21. SWITCHING TIME vs NEGATIVE SUPPLY VOLTAGE

The information contained in this section has been developed through characterization and is for use as application and design information only. No guarantee is implied.

Typical Performance Curves $T_A = +25^\circ\text{C}$, $V_{\text{SUPPLY}} = \pm 15\text{V}$, $V_{\text{AH}} = 3.0\text{V}$, $V_{\text{AL}} = 0.8\text{V}$ (Continued)

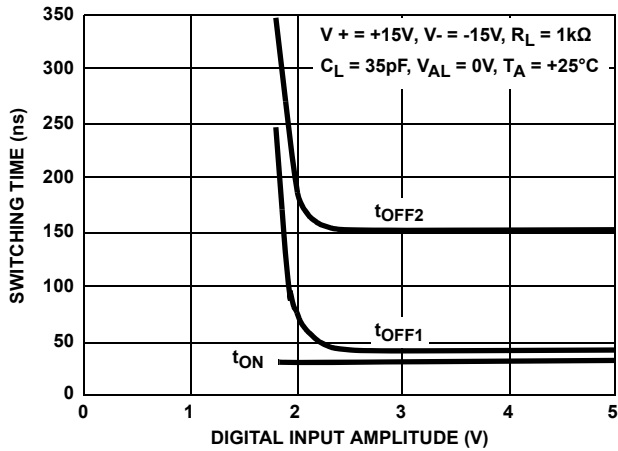

FIGURE 22. SWITCHING TIME vs INPUT LOGIC AMPLITUDE

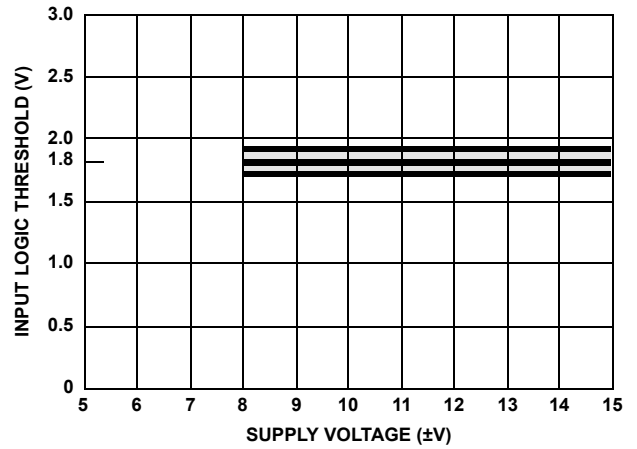

FIGURE 23. INPUT SWITCHING THRESHOLD vs POSITIVE AND NEGATIVE SUPPLY VOLTAGE

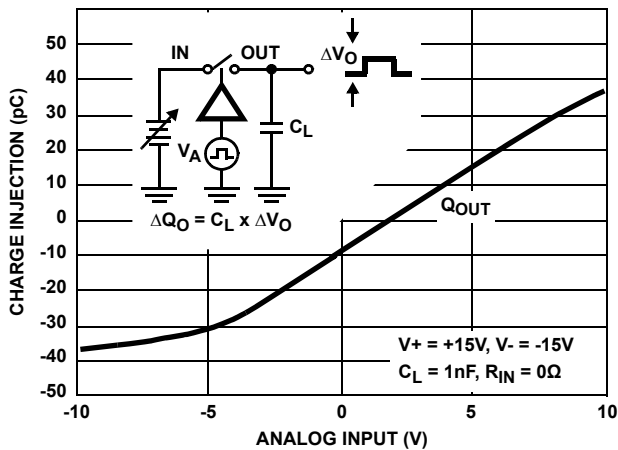

FIGURE 24. CHARGE INJECTION vs ANALOG INPUT

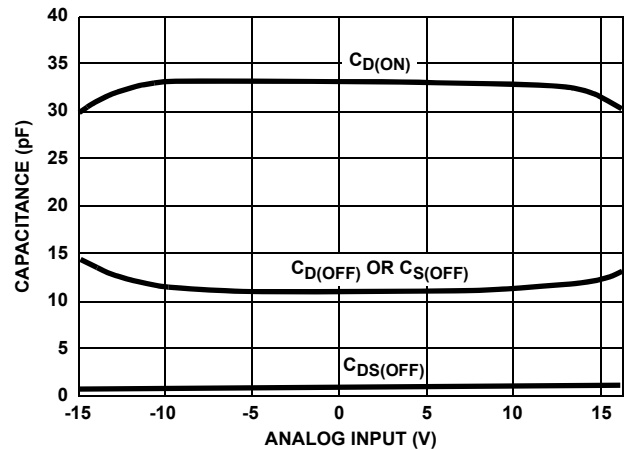

FIGURE 25. CAPACITANCE vs ANALOG INPUT

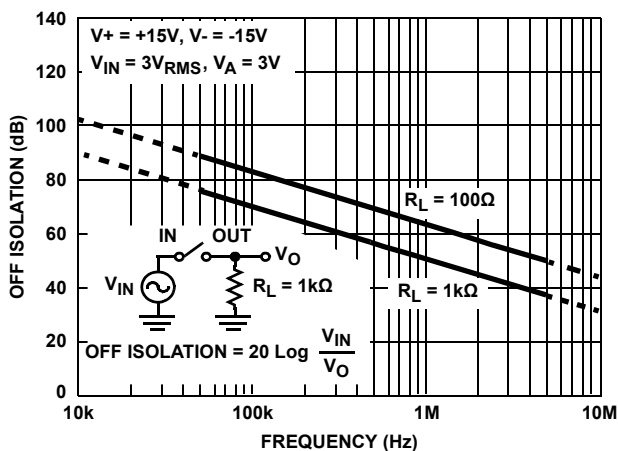

FIGURE 26. OFF ISOLATION vs FREQUENCY

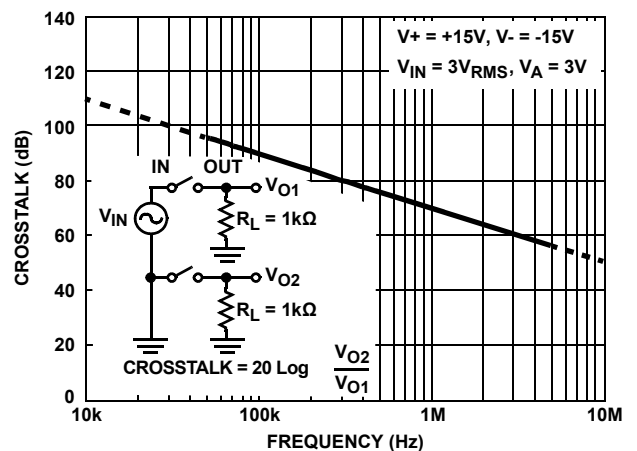
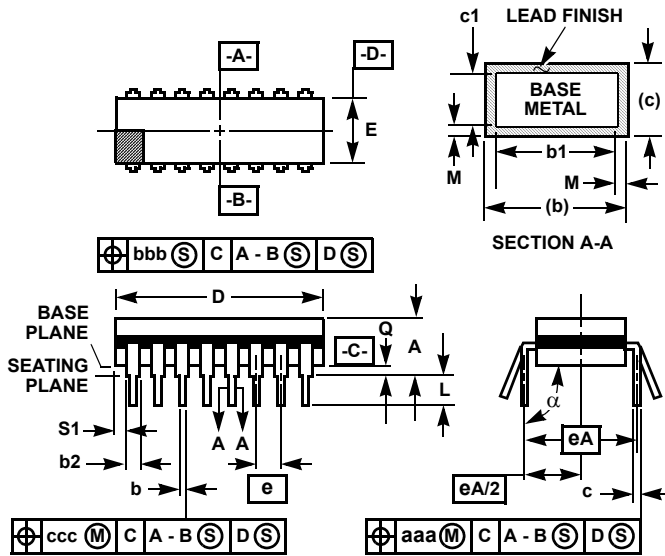

FIGURE 27. CROSSTALK vs FREQUENCY

Ceramic Dual-In-Line Frit Seal Packages (CERDIP)



NOTES:

1. Index area: A notch or a pin one identification mark shall be located adjacent to pin one and shall be located within the shaded area shown. The manufacturer's identification shall not be used as a pin one identification mark.
2. The maximum limits of lead dimensions b and c or M shall be measured at the centroid of the finished lead surfaces, when solder dip or tin plate lead finish is applied.
3. Dimensions b1 and c1 apply to lead base metal only. Dimension M applies to lead plating and finish thickness.
4. Corner leads (1, N, N/2, and N/2+1) may be configured with a partial lead paddle. For this configuration dimension b3 replaces dimension b2.
5. This dimension allows for off-center lid, meniscus, and glass overrun.
6. Dimension Q shall be measured from the seating plane to the base plane.
7. Measure dimension S1 at all four corners.
8. N is the maximum number of terminal positions.
9. Dimensioning and tolerancing per ANSI Y14.5M - 1982.
10. Controlling dimension: INCH.

**F16.3 MIL-STD-1835 GDIP1-T16 (D-2, CONFIGURATION A)
16 LEAD CERAMIC DUAL-IN-LINE FRIT SEAL PACKAGE**

SYMBOL	INCHES		MILLIMETERS		NOTES
	MIN	MAX	MIN	MAX	
A	-	0.200	-	5.08	-
b	0.014	0.026	0.36	0.66	2
b1	0.014	0.023	0.36	0.58	3
b2	0.045	0.065	1.14	1.65	-
b3	0.023	0.045	0.58	1.14	4
c	0.008	0.018	0.20	0.46	2
c1	0.008	0.015	0.20	0.38	3
D	-	0.840	-	21.34	5
E	0.220	0.310	5.59	7.87	5
e	0.100 BSC		2.54 BSC		-
eA	0.300 BSC		7.62 BSC		-
eA/2	0.150 BSC		3.81 BSC		-
L	0.125	0.200	3.18	5.08	-
Q	0.015	0.060	0.38	1.52	6
S1	0.005	-	0.13	-	7
α	90°	105°	90°	105°	-
aaa	-	0.015	-	0.38	-
bbb	-	0.030	-	0.76	-
ccc	-	0.010	-	0.25	-
M	-	0.0015	-	0.038	2, 3
N	16		16		8

Rev. 0 4/94

© Copyright Intersil Americas LLC 1989-2012. All Rights Reserved.
All trademarks and registered trademarks are the property of their respective owners.

For additional products, see www.intersil.com/en/products.html

Intersil products are manufactured, assembled and tested utilizing ISO9001 quality systems as noted in the quality certifications found at www.intersil.com/en/support/qualandreliability.html

Intersil products are sold by description only. Intersil may modify the circuit design and/or specifications of products at any time without notice, provided that such modification does not, in Intersil's sole judgment, affect the form, fit or function of the product. Accordingly, the reader is cautioned to verify that datasheets are current before placing orders. Information furnished by Intersil is believed to be accurate and reliable. However, no responsibility is assumed by Intersil or its subsidiaries for its use; nor for any infringements of patents or other rights of third parties which may result from its use. No license is granted by implication or otherwise under any patent or patent rights of Intersil or its subsidiaries.

For information regarding Intersil Corporation and its products, see www.intersil.com

Mouser Electronics

Authorized Distributor

Click to View Pricing, Inventory, Delivery & Lifecycle Information:

[Renesas Electronics:](#)

[HI1-0201HS/883](#) [5962-86716012A](#) [5962-8671601EA](#)

Looking for pricing, stock, or lifecycle information?

Click below to explore more details on WIN SOURCE:

-  [View 5962-86716012A on WIN SOURCE](#)
-  [Renesas Electronics America](#) Information

Optimize Your Supply Chain with WIN SOURCE Solutions

-  Global Sourcing Solution
-  Obsolete Management
-  Cost Control Management
-  Shortage Management
-  Alternative Solution
-  Excess Inventory Management