

THIS DRAWING IS UNPUBLISHED.		RELEASED FOR PUBLICATION
© COPYRIGHT - By -		ALL RIGHTS RESERVED.
HOUSING CAP	STAINLESS STEEL PER ASTM-A484 AND ASTM-A582, TYPE 303	GOLD PLATE PER ASTM-B-488
DIELECTRIC	PTFE FLUOROCARBON PER ASTM-D-1457	N/A
CENTER CONTACT CONTACT EXTENSIONS	BERYLLIUM COPPER PER ASTM-B-196 OR ASTM-B-197, ALLOY C17300, CONDITION H	GOLD PLATE PER ASTM-B-488
COMPONENT	MATERIAL	FINISH

LOC	DIST	REVISIONS					
-	-	P	LTR	DESCRIPTION	DATE	DWN	APVD
		B		REV PER ECO 11-021365	10-26-11	CT	DW

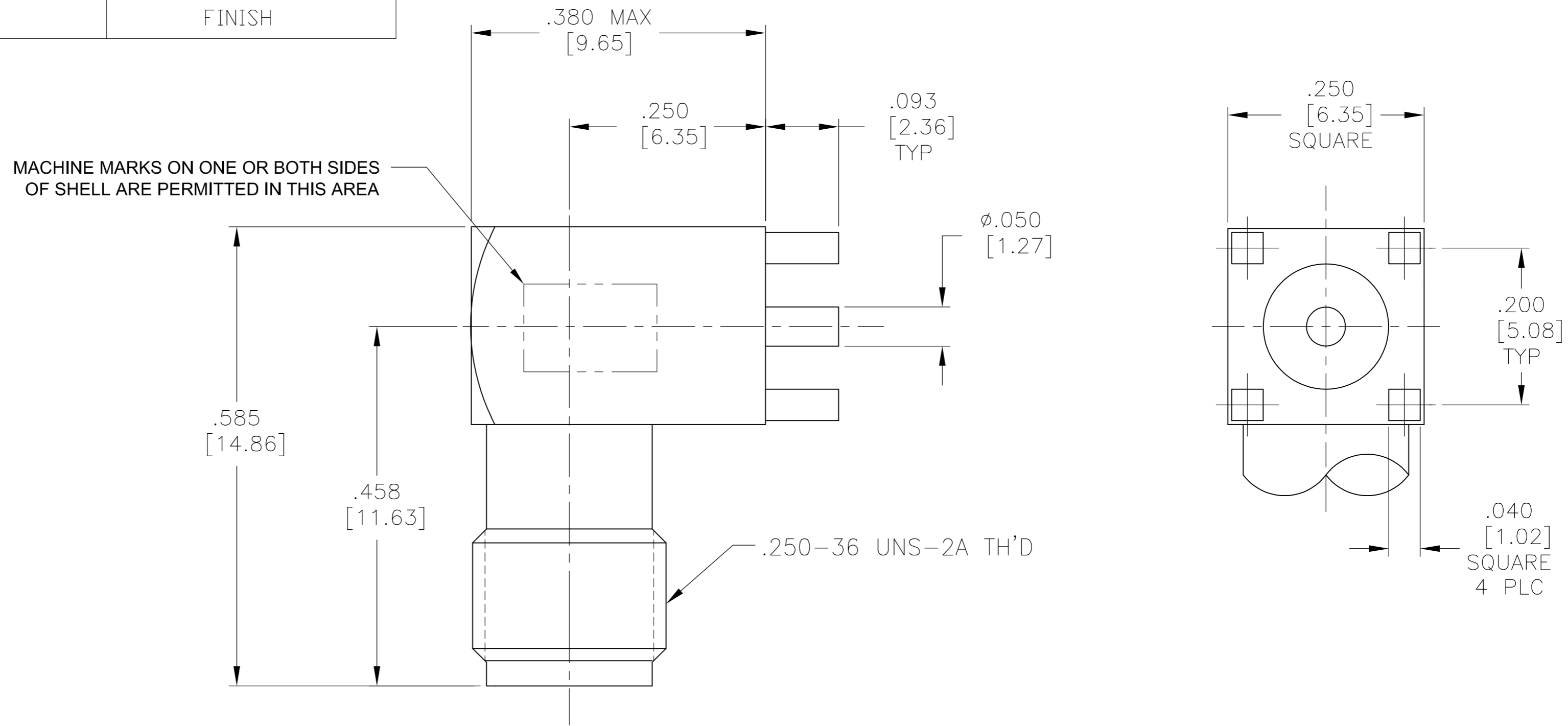

ELECTRICAL	MECHANICAL	ENVIRONMENTAL
Nominal Impedance (Ohms) <u>50</u>	Interface Dimensions MIL-STD-348 <u>310.2</u>	TEMPERATURE RATING <u>-65° TO 105°C</u>
Frequency Range (GHz) <u>.5 to 18</u>	Mating Characteristics:	Vibration - MIL-STD-202, Method 204, Condition D
Volt Rating (VRMS MAX) <u>335</u>	Insertion (MAX Lbs) <u>3.0</u>	Shock - MIL-STD-202, Method 213, Condition I
VSWR <u>N/A</u>	Withdrawal (MIN Oz) <u>1.0</u>	Thermal shock MIL-STD-202, Method 107 Test Condition B
Insertion Loss (dB MAX) <u>N/A</u>	Connector Engagement and Disengagement (In/Lbs MAX) <u>2</u>	EXCEPT HIGH TEMP 125°C
RF Leakage <u>N/A</u>	Center Contact Captivation	Moisture Resistance - MIL-STD-202, Method 106
Corona, 70,000 Ft (VRMS MIN) <u>250</u>	Axial <u>6.0 LBS MIN</u>	Corrosion - MIL-STD-202, Method 101, Condition B
Dielectric Withstanding Voltage (VRMS MIN) <u>1000</u>	Radial <u>4.0 IN/OZ MIN</u>	
Contact Resistance (Milliohms MAX)	Weight (Grams) <u>TBD</u>	
Center Contact <u>3.0</u>		
Outer Contact <u>2.0</u>		
RF High Potential (VRMS MIN @ 5 MHz) <u>670</u>		
I.R.(Megohms) <u>5000 MIN</u>		

1. CAPTURED CENTER CONTACT

M39012/94-3003	1053400-1
MILITARY NUMBER	PART NO.

THIS DRAWING IS A CONTROLLED DOCUMENT.		DWN C.C.THOMAS 26OCT2011	TE Connectivity	
DIMENSIONS: INCHES [mm]		CHK D.WILSON 10-26-11	NAME SMA RIGHT ANGLE PCB JACK ASSEMBLY	
TOLERANCES UNLESS OTHERWISE SPECIFIED:		APVD D.WILSON 10-26-11	SIZE A2 CAGE CODE 00779 DRAWING NO. 1053400	
0 PLC ± -		PRODUCT SPEC	RESTRICTED TO	
1 PLC ± -		APPLICATION SPEC	SCALE 8:1 SHEET 1 of 1 REV B	
2 PLC ± -		WEIGHT -		
3 PLC ± .005 [0.13]		CUSTOMER DRAWING		
4 PLC ± -				
ANGLES ± -				
FINISH -				

Looking for pricing, stock, or lifecycle information?

Click below to explore more details on WIN SOURCE:

 [View 1053400-1 on WIN SOURCE](#)

 [TE Connectivity Information](#)

Optimize Your Supply Chain with WIN SOURCE Solutions

-  Global Sourcing Solution
-  Obsolete Management
-  Cost Control Management
-  Shortage Management
-  Alternative Solution
-  Excess Inventory Management