



THE DATASHEET OF TPA1882-VR



Features

- Supply Voltage: 4.5 V to 40 V or ± 2.25 V to ± 20 V
- Offset Voltage: ± 15 μ V Maximum
- Differential Input Voltage Range to Supply Rail, can Work as Comparator
- Input Rail to $-V_s$, Rail to Rail Output
- Bandwidth: 12 MHz
- Slew Rate: 12 V/ μ s
- Over-Temperature Protection
- Low Noise: 6 nV/ $\sqrt{\text{Hz}}$ at 1 kHz
- 2 kV HBM, 1 kV CDM
- -40°C to 125°C Operation Temperature Range

Applications

- Instrumentation
- Active Filters, ASIC Input or Output Amplifier
- Sensor Interface
- Motor Control
- Industrial Control
- Low noise power supply

Description

The TPA188X series amplifiers are the newest high supply voltage amplifiers with 15 μ V low offset, low noise, and stable high-frequency response. They incorporate 3PEAK's proprietary and patented design techniques to achieve excellent AC performance with 12 MHz bandwidth, 12 V/ μ s slew rate, and low distortion while drawing only 2000 μ A of quiescent current per amplifier. The input common-mode voltage range extends to V_- , and the outputs swing rail-to-rail.

The TPA188X has an over-temperature protection feature to guarantee chip safety. The output of TPA188X will enter high impedance when the die temperature reaches around 170°C and will recover the function when the die temperature is down to around 150°C . The product has a very small power temperature coefficient, which is helpful for temperature-sensitive applications.

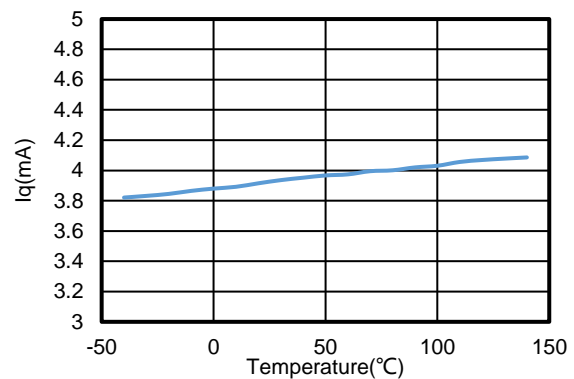

Typical Application Circuit

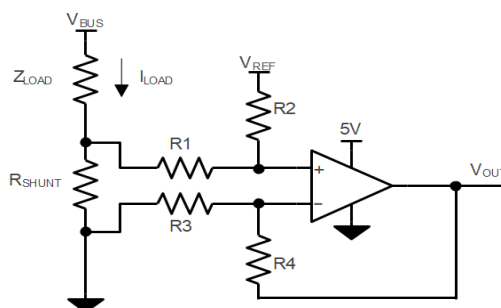

$$V_{OUT} = (I_{LOAD} \times R_{SHUNT}) \times (R2 / R1) + V_{REF}$$

$$\text{When } R3 = R1, R2 = R4, R_{SHUNT} \ll R1$$

Table of Contents

Features	1
Applications	1
Description	1
Typical Application Circuit	1
Revision History	3
Pin Configuration and Functions	4
Specifications	6
Absolute Maximum Ratings.....	6
ESD, Electrostatic Discharge Protection	6
Recommended Operating Conditions	6
Thermal Information	7
Electrical Characteristics	8
Electrical Characteristics (Continued)	9
Electrical Characteristics (Continued)	10
Typical Performance Characteristics.....	11
Detailed Description	14
Overview.....	14
Functional Block Diagram	14
Application and Implementation	15
Low Side Current Sensing Application	15
Power Supply Recommendations	15
Tape and Reel Information	16
Package Outline Dimensions	17
SOT23-5.....	17
SOIC8.....	18
MSOP8.....	19
Order Information	20
IMPORTANT NOTICE AND DISCLAIMER	21

Revision History

Date	Revision	Notes
2019/1/10	Rev.Pre	Pre-Release Version
2020/5/19	Rev.A	Initial Version
2020/8/3	Rev.A.1	Added Test Figure
2020/11/6	Rev.A.2	Updated Test Figure: Iq vs. temperature, Vout vs. Iout
2021/7/7	Rev.A.3	Updated maximum rating: Input voltage: $(-V_s) - 0.3$ to $(+V_s) + 0.3$ -> $(-V_s) - 0.3$ to 40 V Differential Input Voltage : $(+V_s) - (-V_s)$ -> $(-V_s) - (+V_s)$ to $(+V_s) - (-V_s)$
2022/8/18	Rev.A.4	Updated to new document format including package dimensions. Updated the working voltage to 40V, the absolute rating voltage to 42V
2023/6/1	Rev.A.5	Updated address of web site. Updated the working voltage description, added dual-supply description.

Pin Configuration and Functions

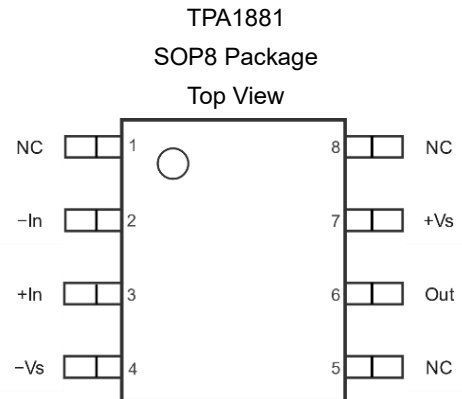
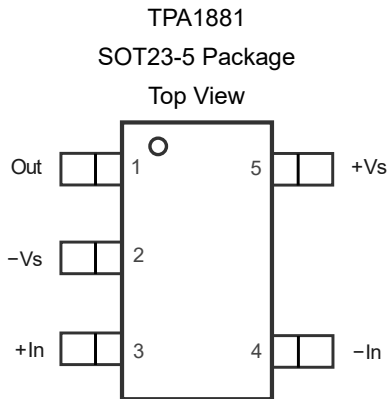

Table 1. Pin Functions: TPA1881

Pin		Name	I/O	Description
SOT23-5	SOP8			
1	6	Out	Output	Output
2	4	-Vs		Negative power supply
3	3	+In	Input	Noninverting input
4	2	-In	Input	Inverting input
5	7	+Vs		Positive power supply
	1	NC		Not connected
	5	NC		Not connected
	8	NC		Not connected

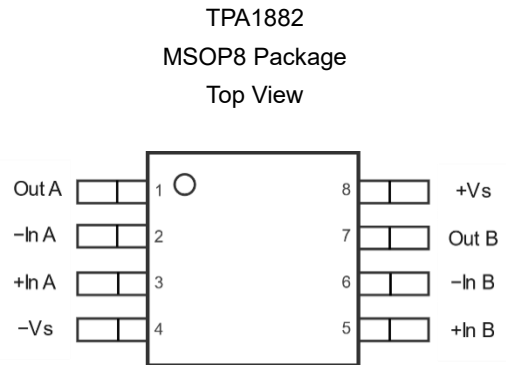
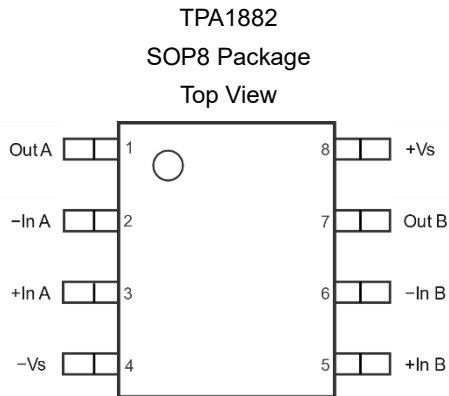

Table 2. Pin Functions: TPA1882

Pin	Name	I/O	Description
1	Out A	Output	Output
2	-In A	Input	Inverting input
3	+In A	Input	Noninverting input
4	-Vs		Negative power supply
5	+In B	Input	Noninverting input
6	-In B	Input	Inverting input
7	Out B	Output	Output
8	+Vs		Positive power supply

Specifications

Absolute Maximum Ratings

Over operating ambient temperature (unless otherwise noted) ⁽¹⁾

Parameter	Min	Max	Unit
Supply Voltage, (+V _S) – (–V _S)		42 V	V
Input Voltage	(–V _S) – 0.3	42 V	V
Differential Input Voltage	(–V _S) – (+V _S)	(+V _S) – (–V _S)	V
Input Current: +I _N , –I _N ⁽²⁾	–10	10	mA
Output Voltage	(–V _S) – 0.3	(+V _S) + 0.3	V
Output Short-Circuit Duration ⁽³⁾		Infinite	
Maximum Operating Junction Temperature		150	°C
Operating Temperature Range	–40	125	°C
Storage Temperature Range	–65	150	°C
Lead Temperature (Soldering, 10 sec)		260	°C

(1) Stresses beyond those listed under Absolute Maximum Ratings may cause permanent damage to the device. Exposure to any Absolute Maximum Rating condition for extended periods may affect device reliability and lifetime.

(2) The inputs are protected by ESD protection diodes to the negative power supply. If the input extends more than 300 mV beyond the negative power supply, the input current should be limited to less than 10 mA.

(3) A heat sink may be required to keep the junction temperature below the absolute maximum. This depends on the power supply voltage and how many amplifiers are shorted. Thermal resistance varies with the amount of PC board metal connected to the package. The specified values are for short traces connected to the leads.

ESD, Electrostatic Discharge Protection

Symbol	Parameter	Condition	Minimum Level	Unit
HBM ⁽¹⁾	Human Body Model ESD	ANSI/ESDA/JEDEC JS-001	2	kV
CDM ⁽²⁾	Charged Device Model ESD	ANSI/ESDA/JEDEC JS-002	1	kV
LU	Latch Up	JESD 78, 25°C	500	mA
		JESD 78, 125°C	200	mA

(1) JEDEC document JEP155 states that 500-V HBM allows safe manufacturing with a standard ESD control process.

(2) JEDEC document JEP157 states that 250-V CDM allows safe manufacturing with a standard ESD control process.

Recommended Operating Conditions

Parameter	Min	Typ	Max	Unit
V _S	Supply Voltage, (+V _S) – (–V _S)	4.5(±2.25)	40(±20)	V
T _A	Operating Temperature Range	–40	125	°C

Thermal Information

Package Type	θ_{JA}	θ_{JC}	Unit
SOT23-5	250	81	°C/W
SOP8	158	43	°C/W
MSOP8	210	45	°C/W

Electrical Characteristics

All test condition is $V_S = 30\text{ V}$, $T_A = 25^\circ\text{C}$, $R_L = 10\text{ k}\Omega$, unless otherwise noted.

Symbol	Parameter	Conditions	T_A	Min	Typ	Max	Unit
Power Supply							
V_S	Supply Voltage Range			4.5		40	V
I_Q	Quiescent Current per Amplifier	$V_S = 40\text{ V}$			2.4	3	mA
PSRR	Power Supply Rejection Ratio	$V_S = 30\text{ V}$			2	2.5	mA
		$V_S = 30\text{ V}$	$-40^\circ\text{C to } 125^\circ\text{C}$			2.7	mA
		$V_S = 5\text{ V}$			1.9	2.4	mA
		$V_S = 5\text{ V}$	$-40^\circ\text{C to } 125^\circ\text{C}$			2.6	mA
		$V_S = 4.5\text{ V to } 36\text{ V}$		135	155		dB
PSRR	Power Supply Rejection Ratio	$V_S = 4.5\text{ V to } 36\text{ V}$	$-40^\circ\text{C to } 125^\circ\text{C}$	130			dB
V_S	Supply Voltage Range			4.5		36	V
Input Characteristics							
V_{OS}	Input Offset Voltage	$V_S = 40\text{ V}, V_{CM} = 20\text{ V}$		-15		15	μV
		$V_S = 30\text{ V}, V_{CM} = 15\text{ V}$		-15		15	μV
			$-40^\circ\text{C to } 125^\circ\text{C}$	-25		25	μV
		$V_S = 5\text{ V}, V_{CM} = 2.5\text{ V}$		-15		15	μV
			$-40^\circ\text{C to } 125^\circ\text{C}$	-25		25	μV
$V_{OS\text{ TC}}$	Input Offset Voltage Drift		$-40^\circ\text{C to } 125^\circ\text{C}$		0.05	0.15	$\mu\text{ V}/^\circ\text{C}$
I_B	Input Bias Current				10		pA
			$-40^\circ\text{C to } 125^\circ\text{C}$		100		pA
I_{OS}	Input Offset Current				100		pA
I_{IN}	Differential Input Current	$V_S = 36\text{ V}, V_{ID} = 36\text{ V}$				100	μA
			$-40^\circ\text{C to } 125^\circ\text{C}$			120	μA
C_{IN}	Input Capacitance	Differential Mode			5		pF
		Common Mode			2.5		pF
A_V	Open-loop Voltage Gain	$R_{LOAD} = 10\text{ k}\Omega, V_{OUT} = 0.5\text{ V to } 29.5\text{ V}$		135	155		dB
			$-40^\circ\text{C to } 125^\circ\text{C}$	130			dB
V_{CMR}	Common-mode Input Voltage Range			(V-)		(V+) – 1.5	V
CMRR	Common Mode Rejection Ratio	$V_{CM} = 0\text{ V to } 28.5\text{ V}$		135	155		dB
			$-40^\circ\text{C to } 125^\circ\text{C}$	130			dB

Electrical Characteristics (Continued)

 All test condition is $V_S = 30\text{ V}$, $T_A = 25^\circ\text{C}$, $R_L = 10\text{ k}\Omega$, unless otherwise noted.

Symbol	Parameter	Conditions	T_A	Min	Typ	Max	Unit
Output Characteristics							
	Output Swing from Positive Rail	$R_{LOAD} = 100\text{ k}\Omega$ to $V_S/2$			12	25	mV
			-40°C to 85°C			35	mV
			-40°C to 125°C			40	mV
		$R_{LOAD} = 10\text{ k}\Omega$ to $V_S/2$			80	120	mV
			-40°C to 85°C			170	mV
			-40°C to 125°C			200	mV
		$R_{LOAD} = 2\text{ k}\Omega$ to $V_S/2$			370	500	mV
			-40°C to 85°C			700	mV
			-40°C to 125°C			750	mV
	Output Swing from Negative Rail	$R_{LOAD} = 100\text{ k}\Omega$ to $V_S/2$			5	25	mV
			-40°C to 85°C			30	mV
			-40°C to 125°C			30	mV
		$R_{LOAD} = 10\text{ k}\Omega$ to $V_S/2$			30	80	mV
			-40°C to 85°C			95	mV
			-40°C to 125°C			105	mV
		$R_{LOAD} = 2\text{ k}\Omega$ to $V_S/2$			140	300	mV
			-40°C to 85°C			450	mV
			-40°C to 125°C			500	mV
I_{sc}	Output Short-Circuit Current	Source		70	95		mA
			-40°C to 85°C	55			mA
			-40°C to 125°C	50			mA
		Sink		130	150		mA
			-40°C to 85°C	100			mA
			-40°C to 125°C	85			mA

Electrical Characteristics (Continued)

All test condition is $V_S = 30\text{ V}$, $T_A = 25^\circ\text{C}$, $R_L = 10\text{ k}\Omega$, unless otherwise noted.

Symbol	Parameter	Conditions	T_A	Min	Typ	Max	Unit
AC Specifications							
GBW	Gain-Bandwidth Product				12		MHz
SR	Slew Rate	$G = 1$, 10 V step		8	12		V/ μs
			-40°C to 125°C	7			V/ μs
t_{OR}	Overload Recovery				500		ns
t_S	Settling Time, 0.1%	$G = 1$, 10 V step			5		μs
	Settling Time, 0.01%				7		μs
PM	Phase Margin	$R_L=10\text{ K}$, $C_L= 50\text{ pF}$			60		$^\circ$
GM	Gain Margin	$R_L=10\text{ K}$, $C_L= 50\text{ pF}$			10		dB
Noise Performance							
E_N	Input Voltage Noise	$f = 0.1\text{ Hz}$ to 10 Hz			0.1		μV_{PP}
e_N	Input Voltage Noise Density	$f = 0.1\text{ kHz}$			6		nV/ $\sqrt{\text{Hz}}$
		$f = 1\text{ kHz}$			6		nV/ $\sqrt{\text{Hz}}$
		$f = 10\text{ kHz}$			7		nV/ $\sqrt{\text{Hz}}$
i_N	Input Current Noise	$f = 10\text{ kHz}$			200		fA/ $\sqrt{\text{Hz}}$
THD+N	Total Harmonic Distortion and Noise	$f = 1\text{ kHz}$, $G = 1$, $R_L = 10\text{ k}\Omega$, $V_{OUT} = 6\text{ V}_{RMS}$			0.0002		%

Typical Performance Characteristics

Test condition: $V_S = \pm 15\text{ V}$, $V_{CM} = 0\text{ V}$, $R_L = 10\text{ k}\Omega$, unless otherwise specified.

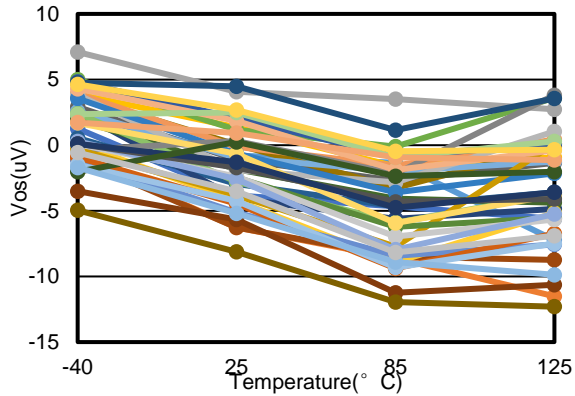

Figure 1. V_{os} at 30 V V_S , 15 V V_{CM} vs. Temperature, 40pcs

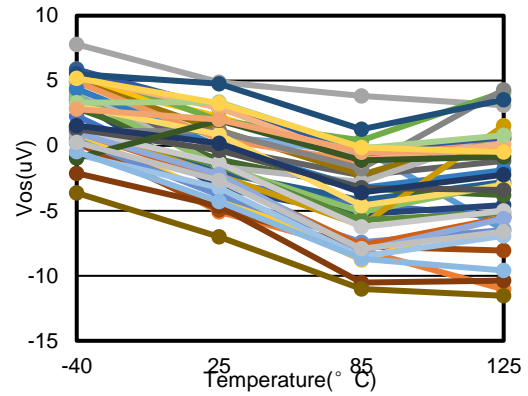

Figure 2. V_{os} at 5 V V_S , 2.5 V V_{CM} vs. Temperature, 40pcs

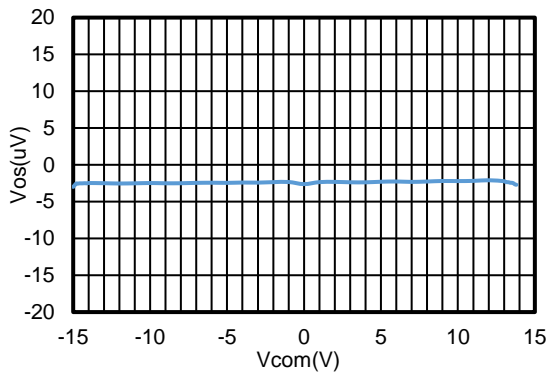

Figure 3. Offset Voltage vs. Common-Mode Voltage

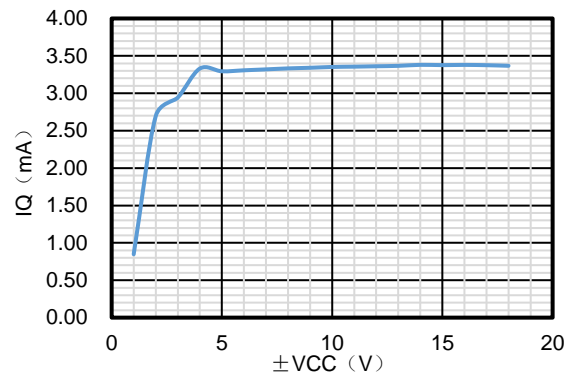

Figure 4. I_q vs. Supply Voltage

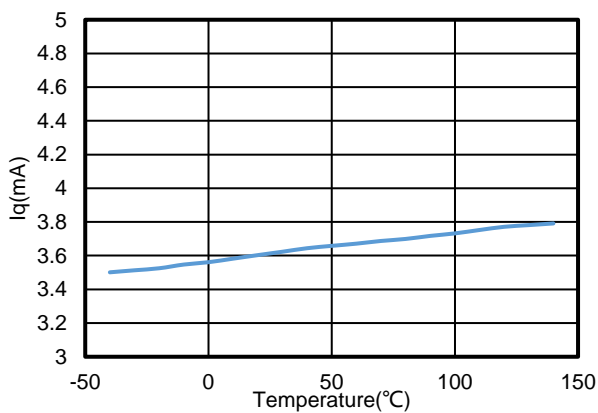

Figure 5. I_q vs. Temperature, $\pm 2.5\text{ V}$ Supply, TPA1882

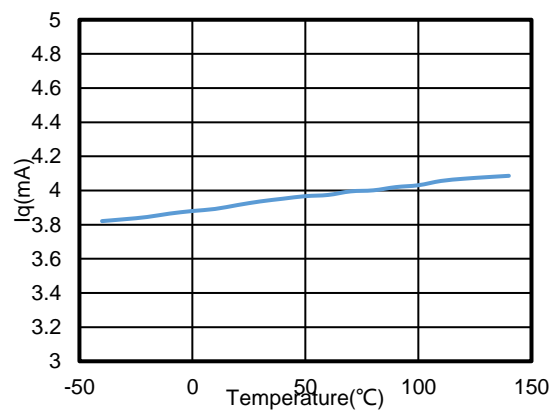

Figure 6. I_q vs. Temperature, $\pm 15\text{ V}$ Supply, TPA1882

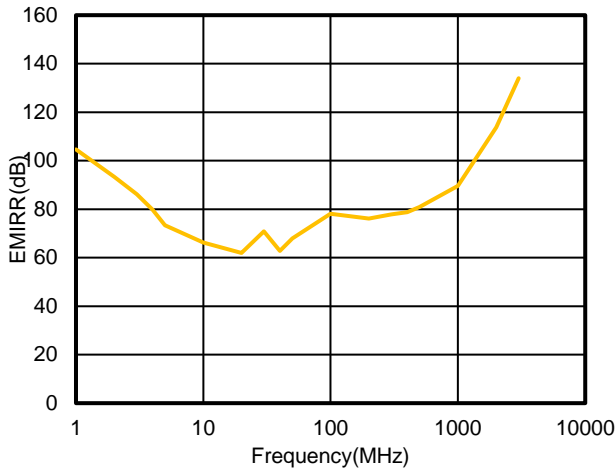

Figure 7. EMIRR vs. Frequency

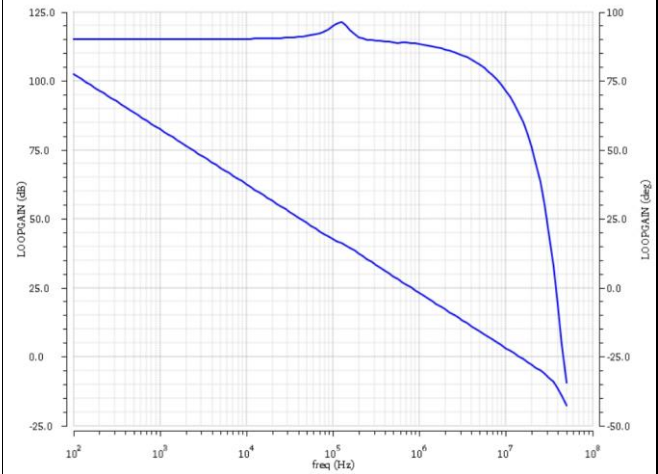

Figure 8. Open Loop Gain and Phase vs. Frequency

$R_L = 10\text{ k}\Omega, C_L = 50\text{ pF}$

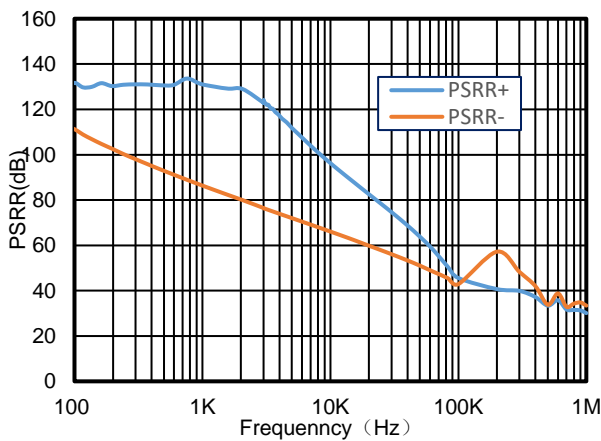

Figure 9. PSRR vs. Frequency

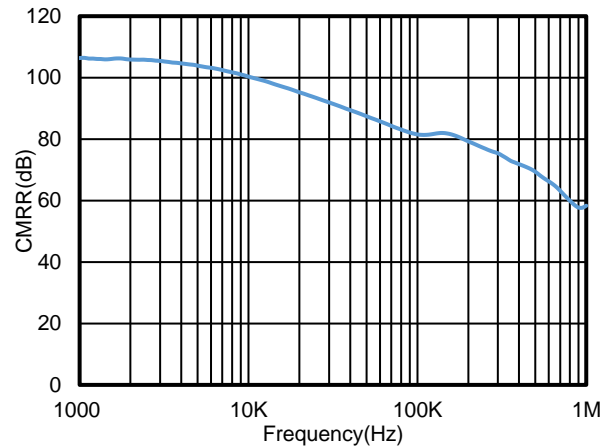
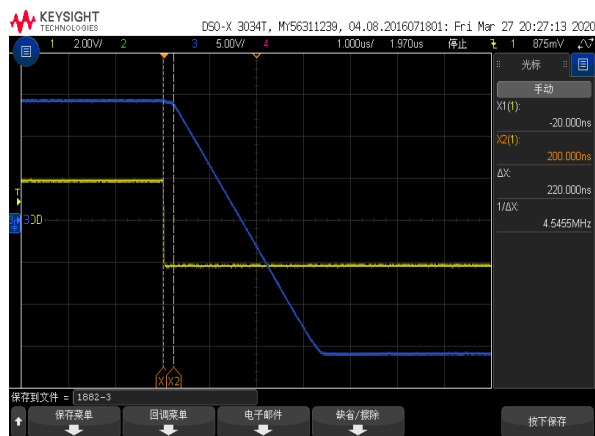
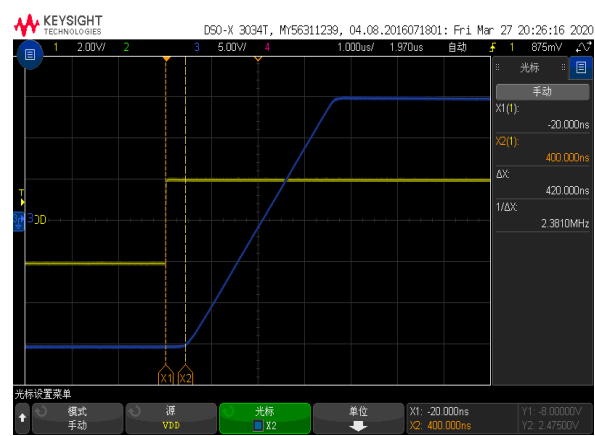

Figure 10. Negative Overload Recovery



Time: 2 us/div, Measure Time: 220 ns
 $R_L=2\text{ K}, C_L=100\text{ pF}, G=10$

Figure 11. Positive Overload Recovery



Time: 2 us/div, Measure Time: 420 ns
 $R_L=2\text{ K}, C_L=100\text{ pF}, G=10$

Figure 12. Negative Overload Recovery

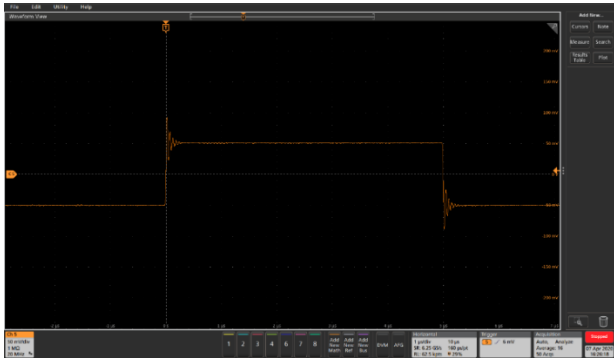

Voltage: 50 mV/div, Time: 2 us/div
 $R_L=2\text{ K}$, $C_L=100\text{ pF}$, $G=1$

Figure 13. 100 mV Signal Step Response

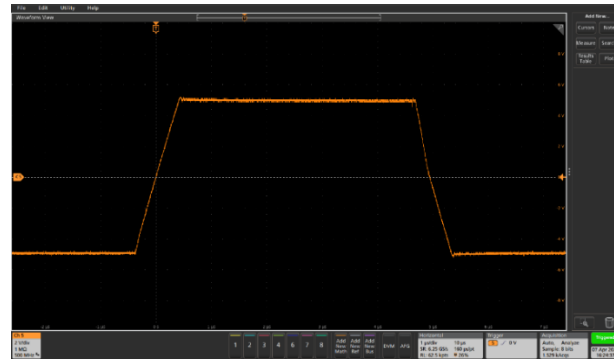

Voltage: 2 V/div, Time: 2 μ s/div
 $R_L=2\text{ K}$, $C_L=100\text{ pF}$, $G=1$

Figure 14. 10 V Signal Step Response

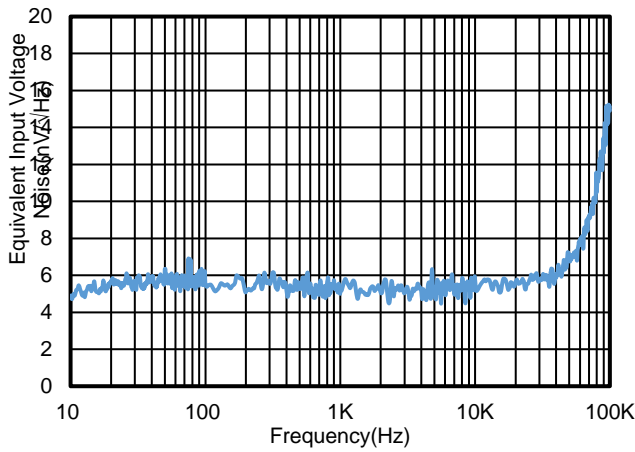

Figure 15. Voltage Noise Spectral Density vs. Frequency

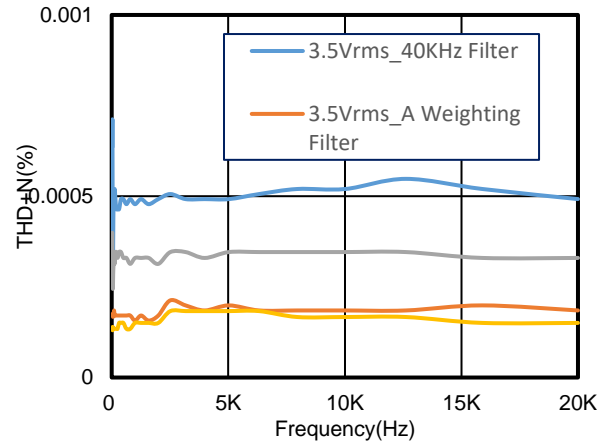

Figure 16. V_{OUT} vs. I_{OUT} , Sink

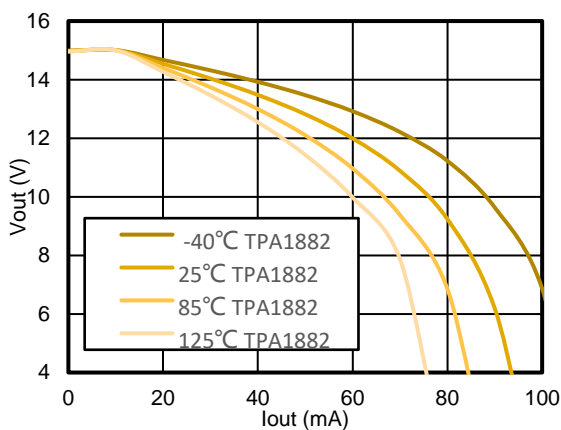

Figure 17. V_{OUT} vs. I_{OUT} , Source

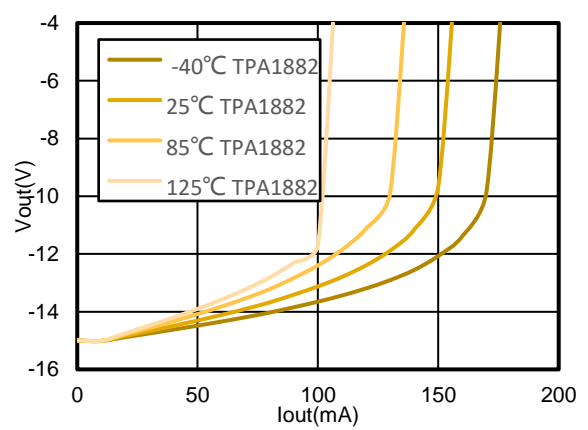

Figure 18. V_{OUT} vs. I_{OUT} , Sink

Detailed Description

Overview

The TPA188x series op amps can operate on a single-supply voltage (4.5 V to 40 V), or a split-supply voltage (± 2.25 V to ± 20 V), making them highly versatile and easy to use. The power-supply pins should have local bypass ceramic capacitors (typically 0.01 μ F to 0.1 μ F). Parameters that can exhibit variance with regard to operating voltage or temperature are presented in the Typical Characteristics.

Functional Block Diagram

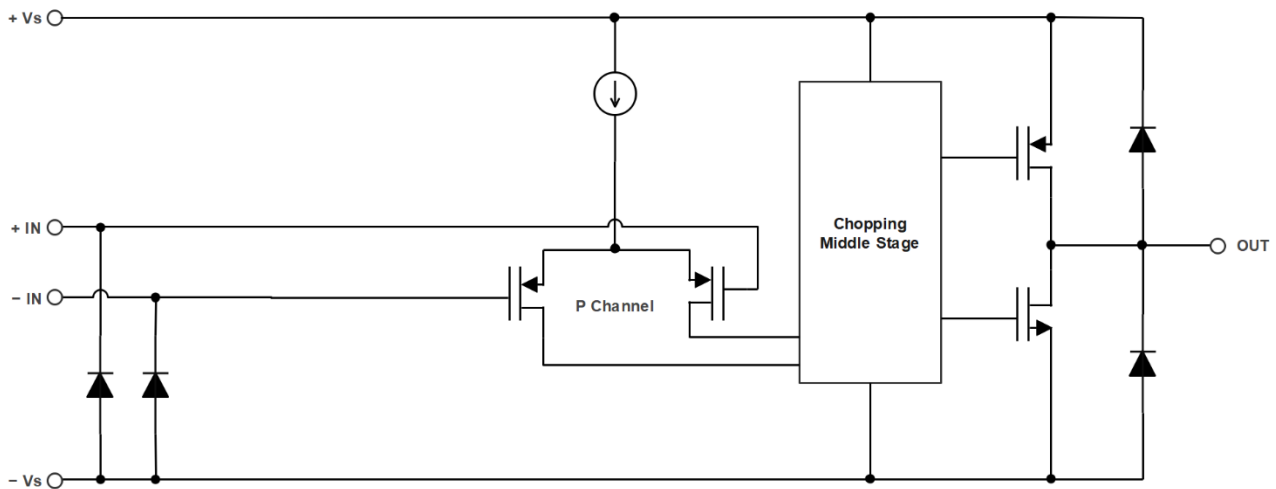

Figure 19. Functional Block Diagram

Application and Implementation

NOTE

Information in the following application sections is not part of the 3PEAK's component specification and 3PEAK does not warrant its accuracy or completeness. 3PEAK's customers are responsible for determining suitability of components for their purposes. Customers should validate and test their design implementation to confirm system functionality.

Low Side Current Sensing Application

Figure 20 shows the TPA188X configured in a low-side current sensing application. The low-side current sensing method consists of placing a sense resistor between the load and the circuit ground. The voltage dropping across the resistor is amplified by different amplifier circuits with TPA188X. The V_{REF} can be used to add bias voltage to output voltage. Particular attention must be paid to the matching and precision of R1, R2, R3, and R4, to maximize the accuracy of the measurement.

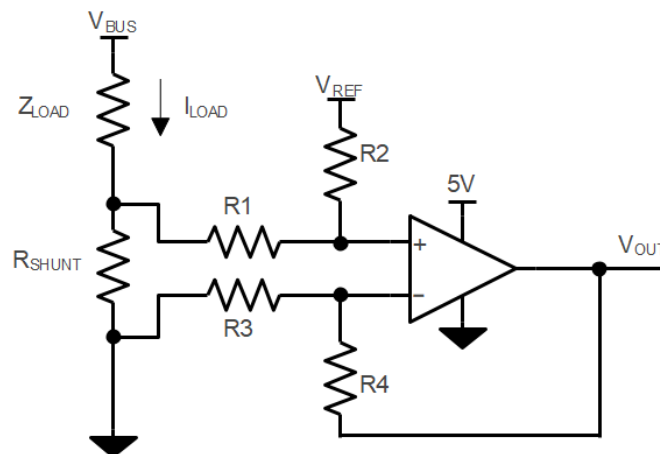

$$V_{OUT} = (I_{LOAD} \times R_{SHUNT}) \times (R2 / R1) + V_{REF}$$

$$\text{When } R3 = R1, R2 = R4, R_{SHUNT} \ll R1$$

Figure 20. Dual Supply Operation Connections

Power Supply Recommendations

Place 0.1- μ F bypass capacitors close to the power supply pins for reducing coupling errors from the noisy or high impedance power supplies.

Tape and Reel Information

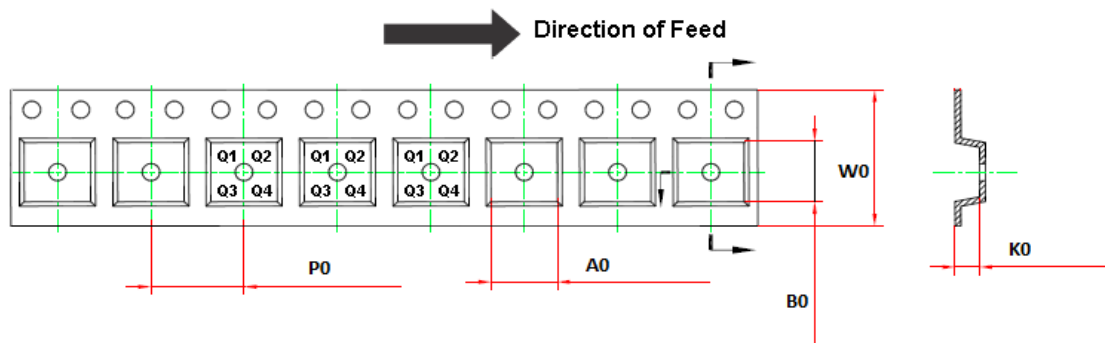
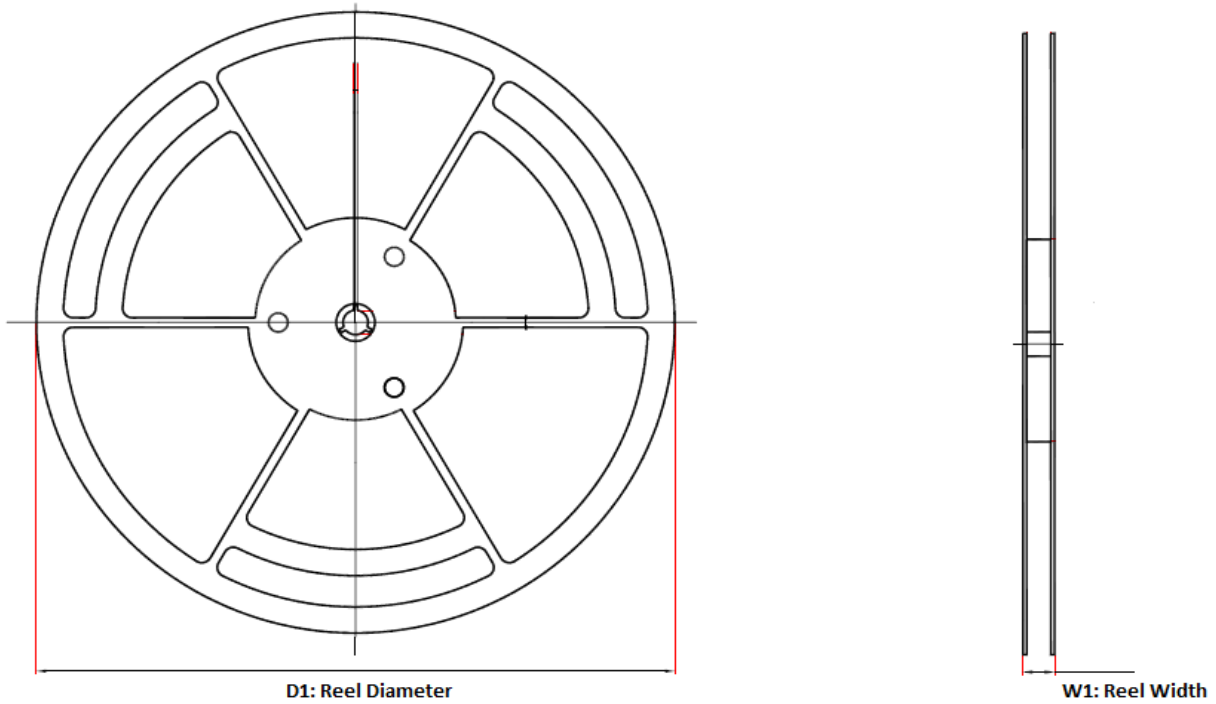

Order Number	Package	D1 (mm)	W1 (mm)	A0 (mm)	B0 (mm)	K0 (mm)	P0 (mm)	W0 (mm)	Pin1 Quadrant
TPA1881-TR	SOT23-5	180.0	13.1	3.2	3.2	1.4	4.0	8.0	Q3
TPA1881-SR	SOP8	330.0	17.6	6.4	5.4	2.1	8.0	12.0	Q1
TPA1882-SR	SOP8	330.0	17.6	6.4	5.4	2.1	8.0	12.0	Q1
TPA1882-VR	MSOP8	330.0	17.6	5.2	3.3	1.5	8.0	12.0	Q1

Package Outline Dimensions

SOT23-5

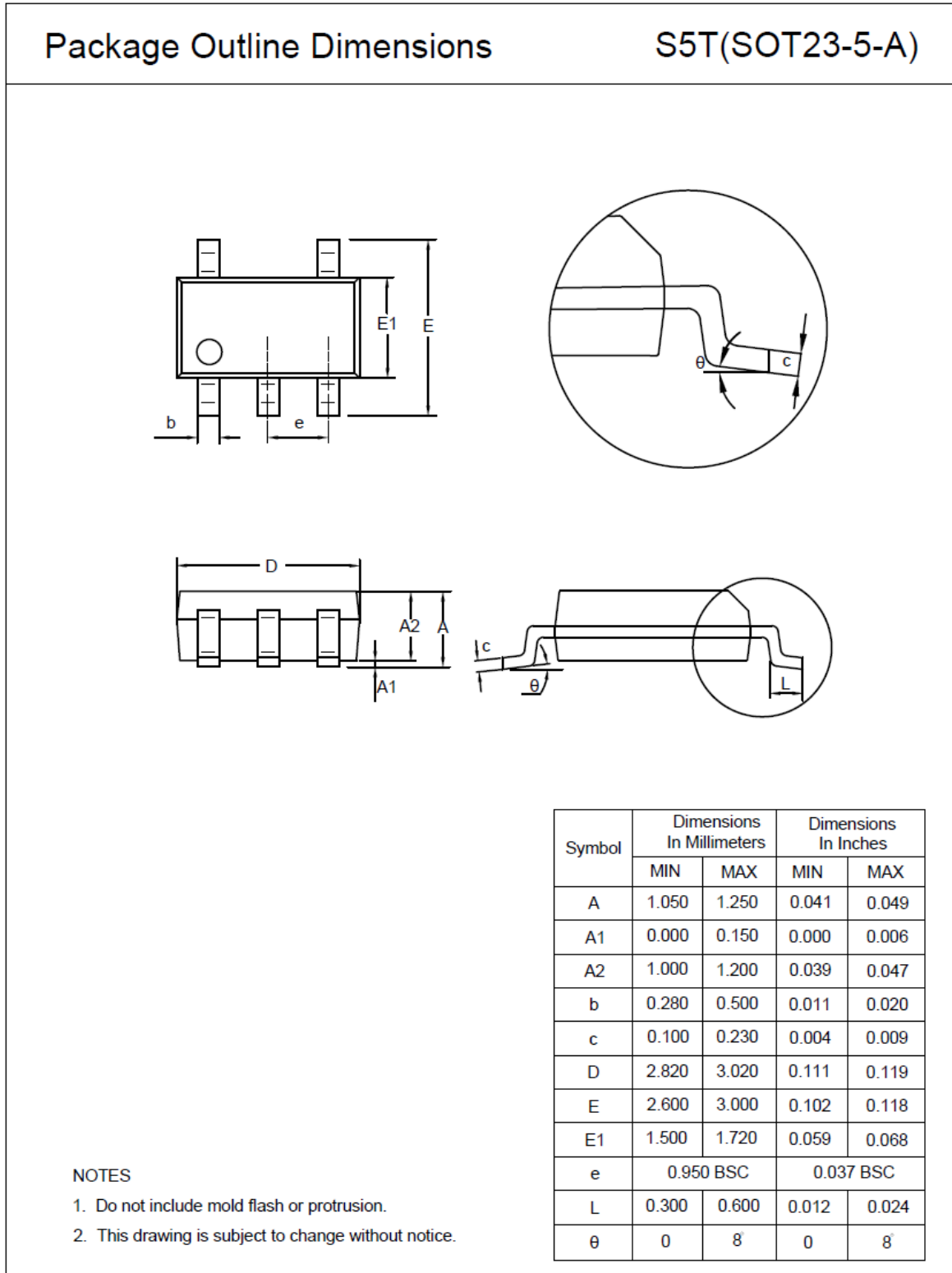

SOIC8

Package Outline Dimensions

SO1(SOP-8-A)

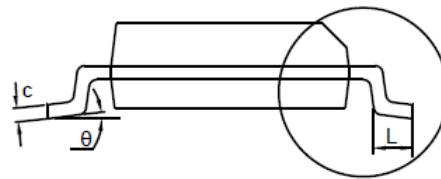
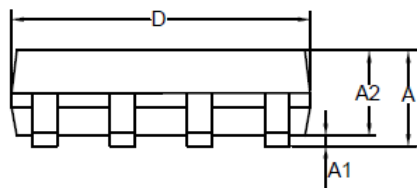
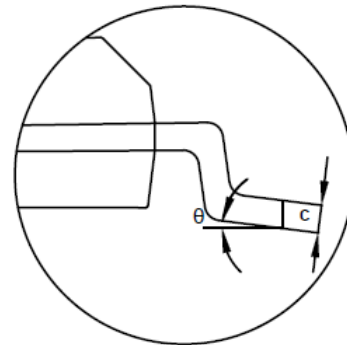
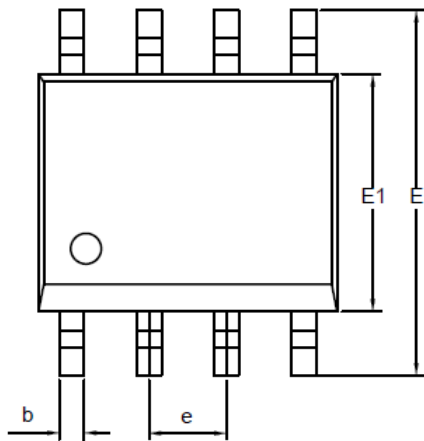

Symbol	Dimensions In Millimeters		Dimensions In Inches	
	MIN	MAX	MIN	MAX
A	1.350	1.750	0.053	0.069
A1	0.050	0.250	0.002	0.010
A2	1.250	1.550	0.049	0.061
b	0.330	0.510	0.013	0.020
c	0.170	0.250	0.007	0.010
D	4.700	5.100	0.185	0.201
E	5.800	6.200	0.228	0.244
E1	3.800	4.000	0.150	0.157
e	1.270 BSC		0.050 BSC	
L	0.400	1.000	0.016	0.039
theta	0	8	0	8

NOTES

1. Do not include mold flash or protrusion.
2. This drawing is subject to change without notice.

MSOP8

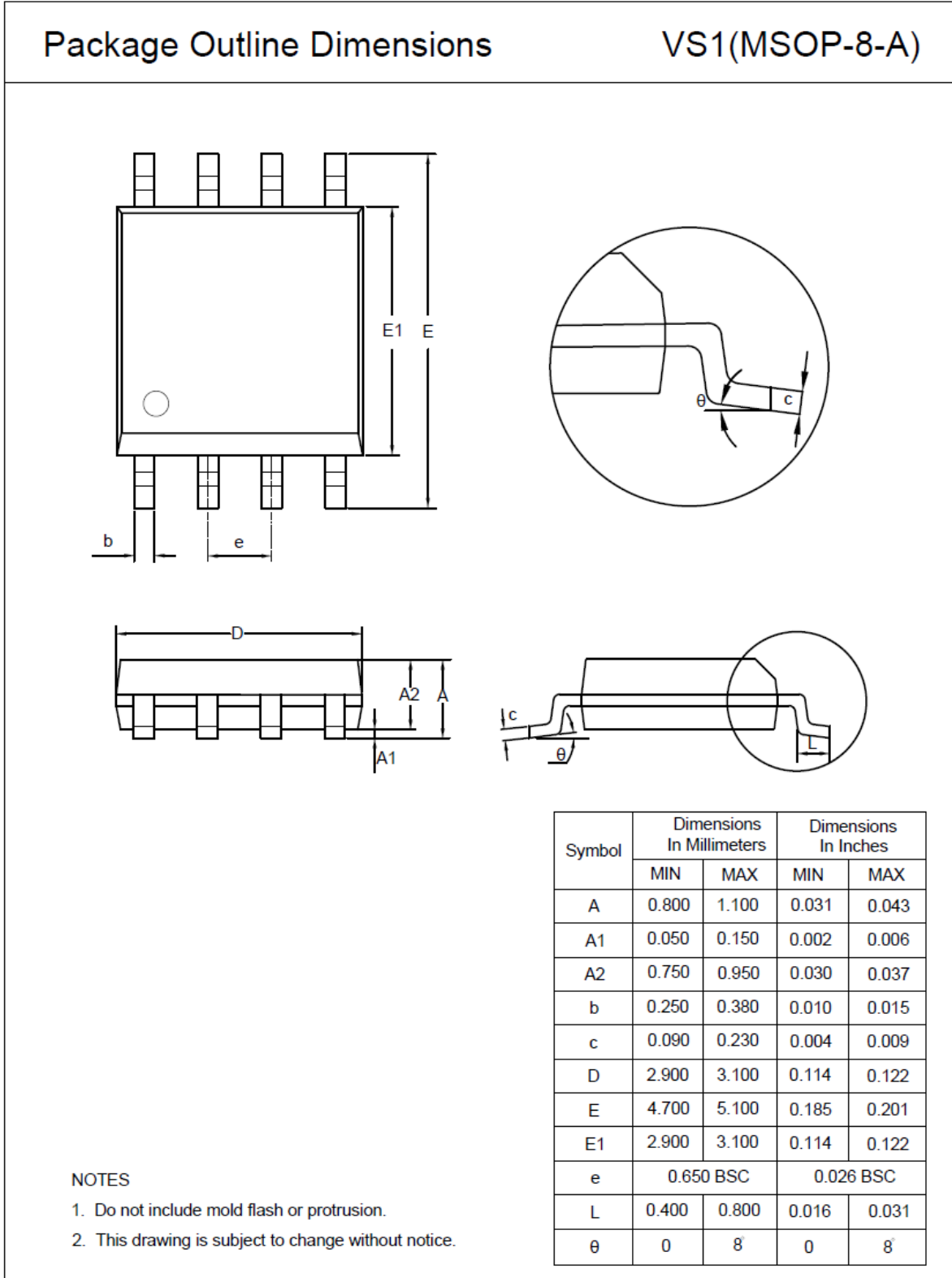

Order Information

Order Number	Operating Temperature Range	Package	Marking Information	MSL	Transport Media, Quantity	Eco Plan
TPA1881-SR	-40 to 125°C	SOP8	1881	3	Tape and Reel, 4000	TPA1881-SR
TPA1881-TR	-40 to 125°C	SOT23-5	A88	3	Tape and Reel, 3000	TPA1881-TR
TPA1882-SR	-40 to 125°C	SOP8	1882	3	Tape and Reel, 4000	TPA1882-SR
TPA1882-VR	-40 to 125°C	MSOP8	1882	3	Tape and Reel, 3000	TPA1882-VR

Green: 3PEAK defines "Green" to mean RoHS compatible and free of halogen substances.

IMPORTANT NOTICE AND DISCLAIMER

Copyright© 3PEAK 2012-2023. All rights reserved.



Trademarks. Any of the 思瑞浦 or 3PEAK trade names, trademarks, graphic marks, and domain names contained in this document /material are the property of 3PEAK. You may NOT reproduce, modify, publish, transmit or distribute any Trademark without the prior written consent of 3PEAK.

Performance Information. Performance tests or performance range contained in this document/material are either results of design simulation or actual tests conducted under designated testing environment. Any variation in testing environment or simulation environment, including but not limited to testing method, testing process or testing temperature, may affect actual performance of the product.

Disclaimer. 3PEAK provides technical and reliability data (including data sheets), design resources (including reference designs), application or other design recommendations, networking tools, security information and other resources "As Is". 3PEAK makes no warranty as to the absence of defects, and makes no warranties of any kind, express or implied, including without limitation, implied warranties as to merchantability, fitness for a particular purpose or non-infringement of any third-party's intellectual property rights. Unless otherwise specified in writing, products supplied by 3PEAK are not designed to be used in any life-threatening scenarios, including critical medical applications, automotive safety-critical systems, aviation, aerospace, or any situations where failure could result in bodily harm, loss of life, or significant property damage. 3PEAK disclaims all liability for any such unauthorized use.

Looking for pricing, stock, or lifecycle information?

Click below to explore more details on WIN SOURCE:

-  [View TPA1882-VR on WIN SOURCE](#)
-  [3Peak Information](#)

Optimize Your Supply Chain with WIN SOURCE Solutions

-  Global Sourcing Solution
-  Obsolete Management
-  Cost Control Management
-  Shortage Management
-  Alternative Solution
-  Excess Inventory Management